

EC2645TTS-16.000M TR

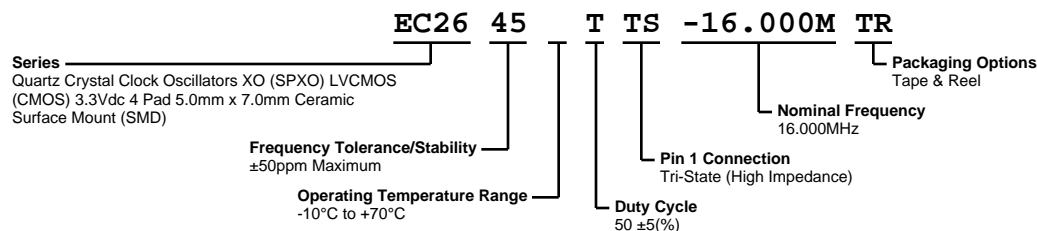

ELECTRICAL SPECIFICATIONS

| | |
|---------------------------------------|--|
| Nominal Frequency | 16.000MHz |
| Frequency Tolerance/Stability | ±50ppm Maximum (Inclusive of all conditions: Calibration Tolerance at 25°C, Frequency Stability over the Operating Temperature Range, Supply Voltage Change, Output Load Change, First Year Aging at 25°C, Shock, and Vibration) |
| Aging at 25°C | ±5ppm/year Maximum |
| Operating Temperature Range | -10°C to +70°C |
| Supply Voltage | 3.3Vdc ±10% |
| Input Current | 10mA Maximum |
| Output Voltage Logic High (Voh) | 90% of Vdd Minimum (IOH=-8mA) |
| Output Voltage Logic Low (Vol) | 10% of Vdd Maximum (IOL=+8mA) |
| Rise/Fall Time | 5nSec Maximum (w/15pF Load), 7nSec Maximum (w/30pF Load) (Measured at 20% to 80% of waveform) |
| Duty Cycle | 50 ±5(%) (Measured at 50% of waveform) |
| Load Drive Capability | 30pF Maximum |
| Output Logic Type | CMOS |
| Pin 1 Connection | Tri-State (High Impedance) |
| Tri-State Input Voltage (Vih and Vil) | +0.7Vdd Minimum or No Connect to Enable Output, +0.3Vdd Maximum to Disable Output (High Impedance) |
| Standby Current | 10µA Maximum (Disabled Output: High Impedance) |
| RMS Phase Jitter | 1pSec Maximum (12kHz to 20MHz offset frequency) |
| Start Up Time | 10mSec Maximum |
| Storage Temperature Range | -55°C to +125°C |

ENVIRONMENTAL & MECHANICAL SPECIFICATIONS

| | |
|------------------------------|---|
| ESD Susceptibility | MIL-STD-883, Method 3015, Class 1, HBM: 1500V |
| Fine Leak Test | MIL-STD-883, Method 1014, Condition A |
| Flammability | UL94-V0 |
| Gross Leak Test | MIL-STD-883, Method 1014, Condition C |
| Mechanical Shock | MIL-STD-883, Method 2002, Condition B |
| Moisture Resistance | MIL-STD-883, Method 1004 |
| Moisture Sensitivity | J-STD-020, MSL 1 |
| Resistance to Soldering Heat | MIL-STD-202, Method 210, Condition K |
| Resistance to Solvents | MIL-STD-202, Method 215 |
| Solderability | MIL-STD-883, Method 2003 |
| Temperature Cycling | MIL-STD-883, Method 1010, Condition B |
| Vibration | MIL-STD-883, Method 2007, Condition A |

EC2645TTS-16.000M TR

MECHANICAL DIMENSIONS (all dimensions in millimeters)

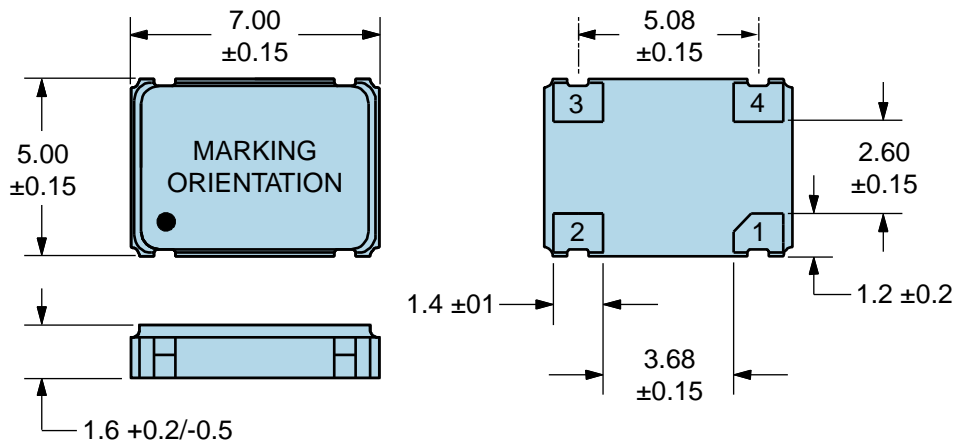

| PIN | CONNECTION |
|-----|--------------------|
| 1 | Tri-State |
| 2 | Ground/Case Ground |
| 3 | Output |
| 4 | Supply Voltage |

| LINE | MARKING |
|------|--|
| 1 | ECLIPTEK |
| 2 | 16.000M |
| 3 | XXXXXX XXXXXX=Ecliptek Manufacturing Identifier |

Suggested Solder Pad Layout

All Dimensions in Millimeters

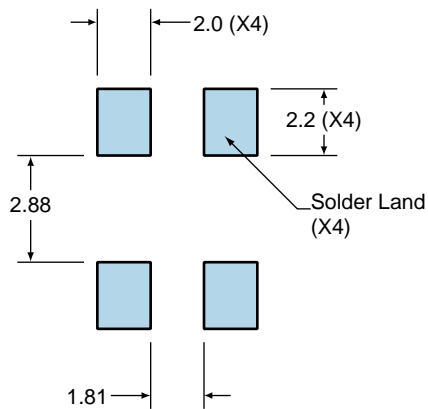

All Tolerances are ± 0.1

EC2645TTS-16.000M TR



OUTPUT WAVEFORM & TIMING DIAGRAM

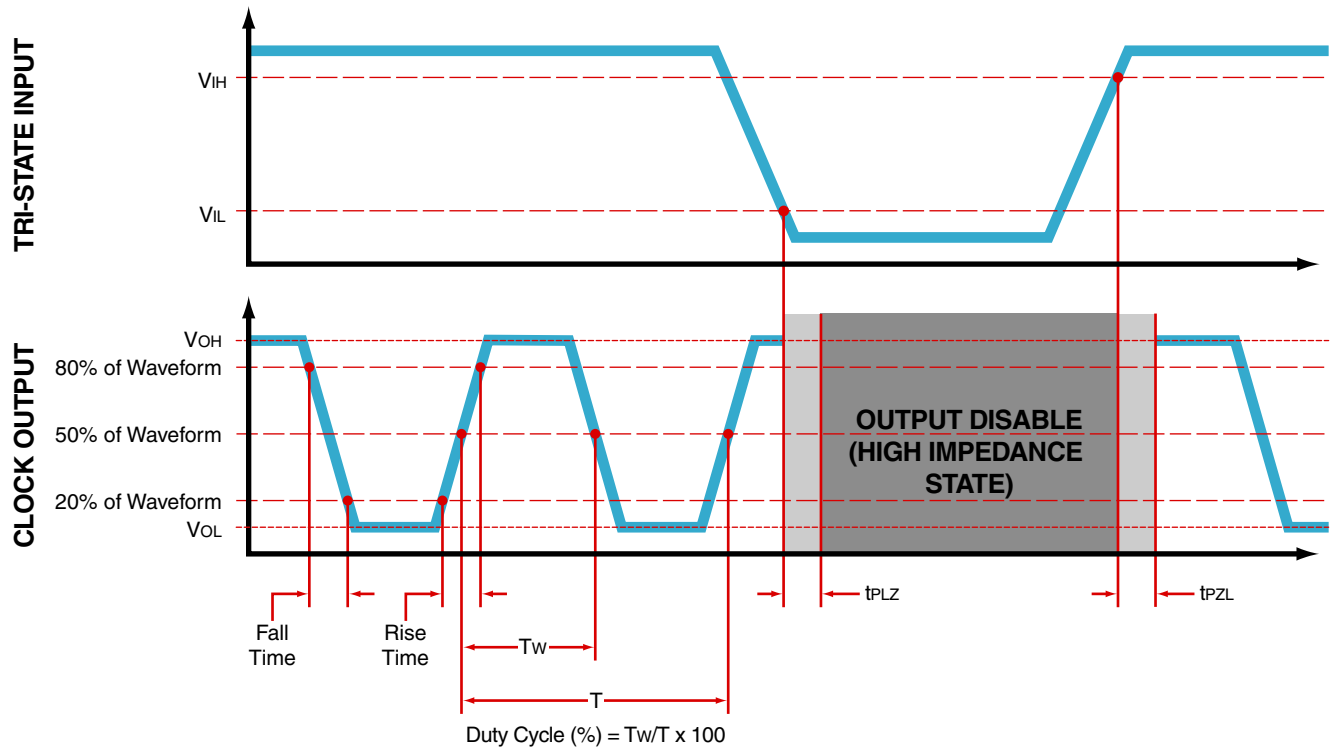

EC2645TTS-16.000M TR

Test Circuit for CMOS Output

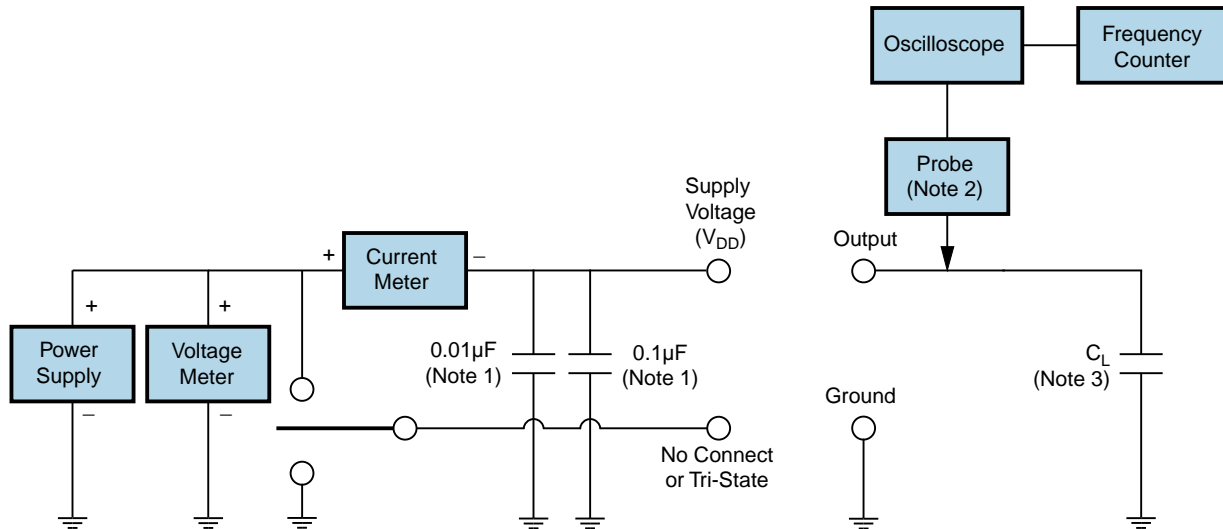

Note 1: An external $0.1\mu\text{F}$ low frequency tantalum bypass capacitor in parallel with a $0.01\mu\text{F}$ high frequency ceramic bypass capacitor close to the package ground and V_{DD} pin is required.

Note 2: A low capacitance ($<12\text{pF}$), 10X attenuation factor, high impedance ($>10\text{Mohms}$), and high bandwidth ($>300\text{MHz}$) passive probe is recommended.

Note 3: Capacitance value C_L includes sum of all probe and fixture capacitance.

EC2645TTS-16.000M TR

Tape & Reel Dimensions

All Dimensions in Millimeters
 Compliant to EIA-481
 Quantity Per Reel: 1,000 units

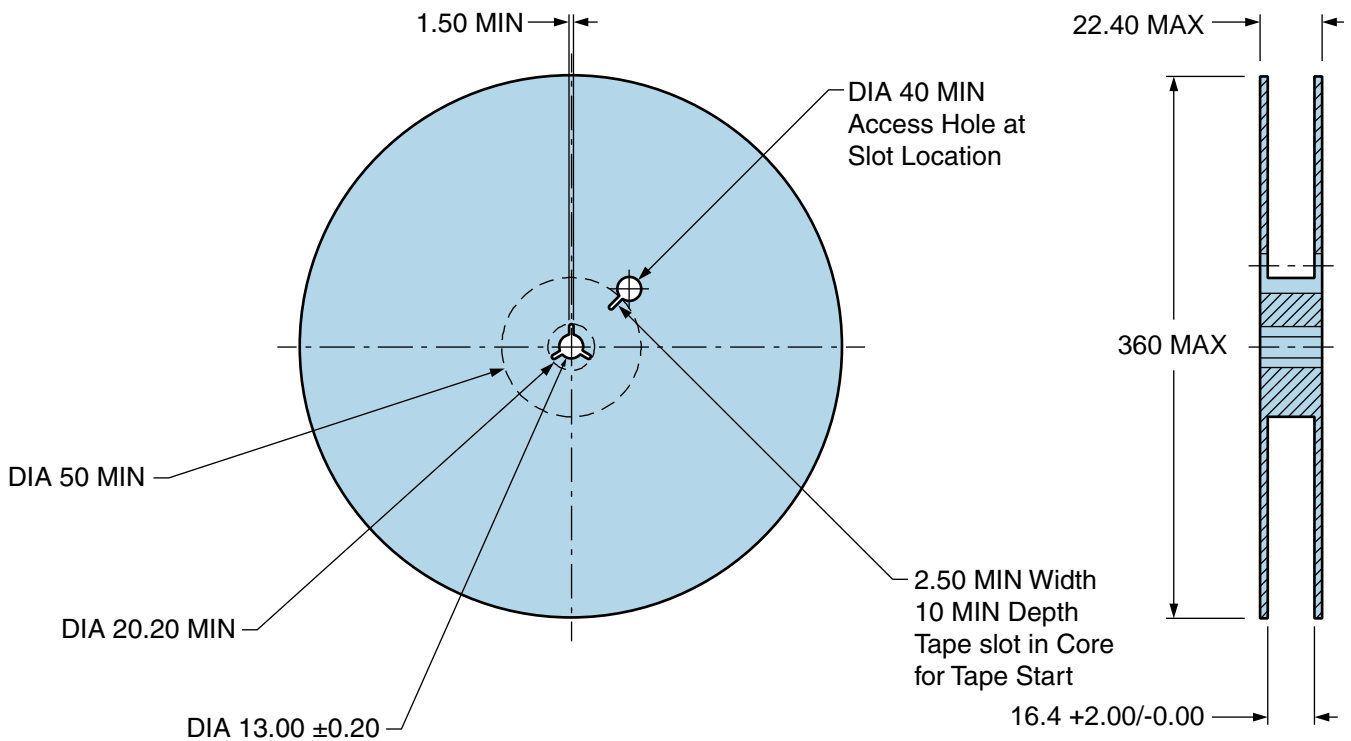
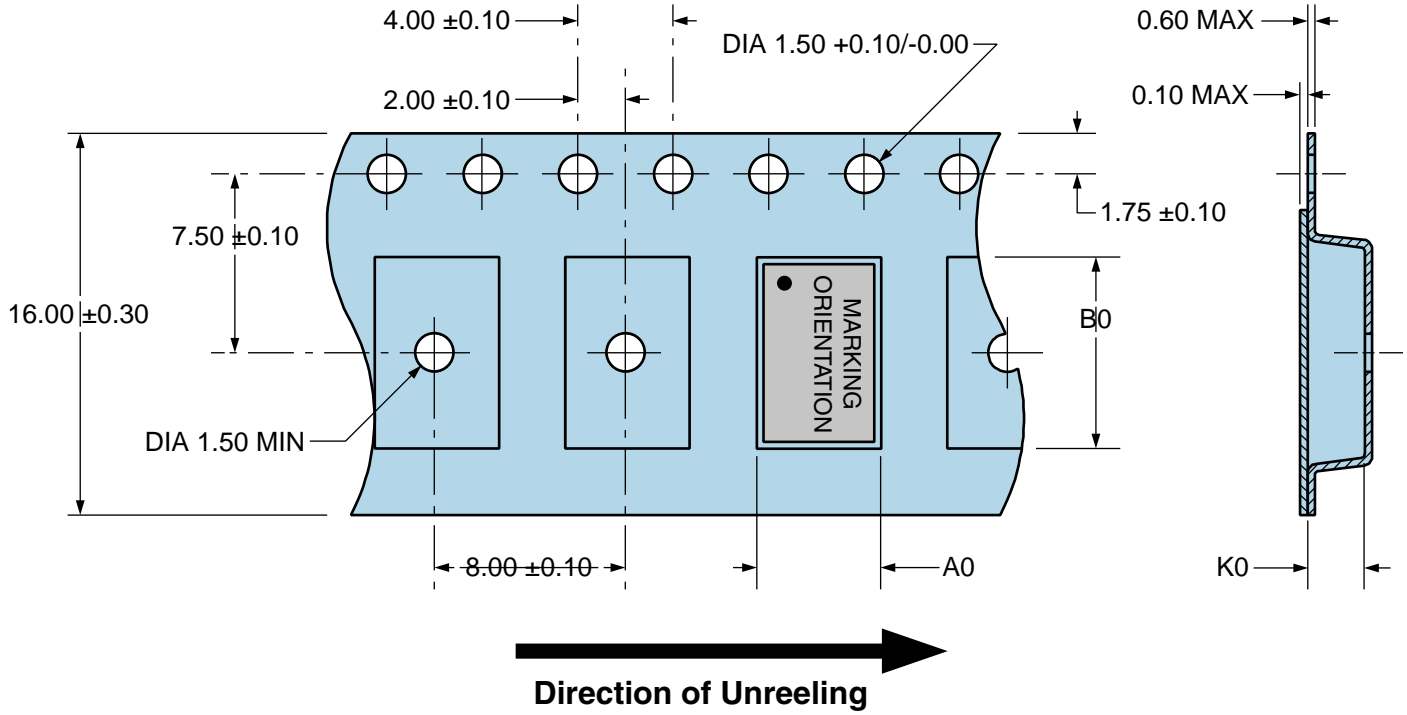

Recommended Solder Reflow Methods

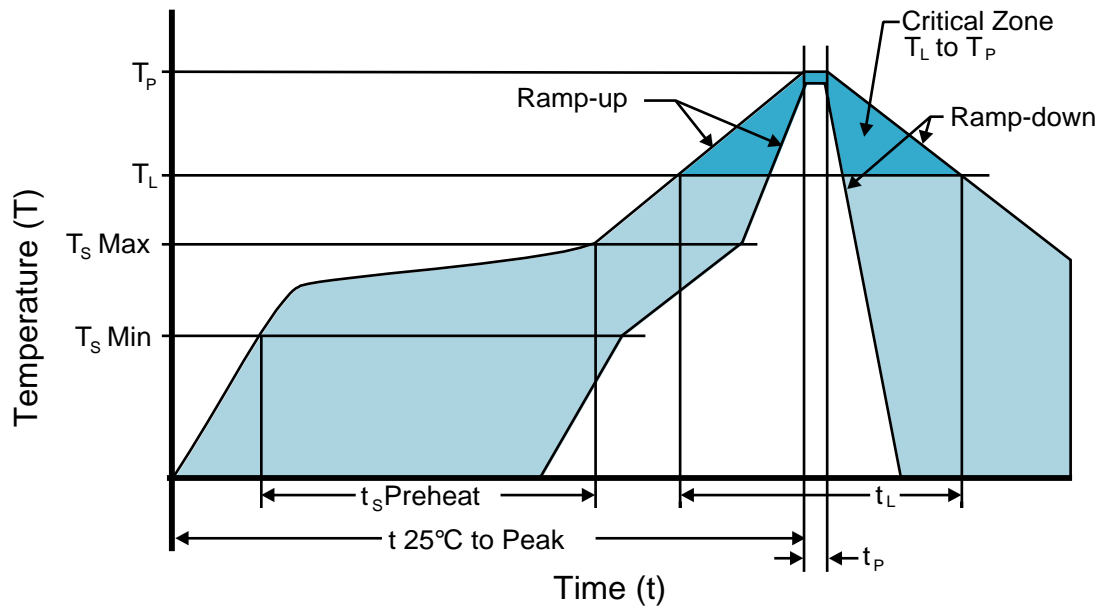

High Temperature Infrared/Convection

| | |
|--|---|
| T_s MAX to T_L (Ramp-up Rate) | 3°C/second Maximum |
| Preheat | |
| - Temperature Minimum (T_s MIN) | 150°C |
| - Temperature Typical (T_s TYP) | 175°C |
| - Temperature Maximum (T_s MAX) | 200°C |
| - Time (t_s MIN) | 60 - 180 Seconds |
| Ramp-up Rate (T_L to T_p) | 3°C/second Maximum |
| Time Maintained Above: | |
| - Temperature (T_L) | 217°C |
| - Time (t_L) | 60 - 150 Seconds |
| Peak Temperature (T_p) | 260°C Maximum for 10 Seconds Maximum |
| Target Peak Temperature (T_p Target) | 250°C +0/-5°C |
| Time within 5°C of actual peak (t_p) | 20 - 40 seconds |
| Ramp-down Rate | 6°C/second Maximum |
| Time 25°C to Peak Temperature (t) | 8 minutes Maximum |
| Moisture Sensitivity Level | Level 1 |
| Additional Notes | Temperatures shown are applied to body of device. |

Recommended Solder Reflow Methods

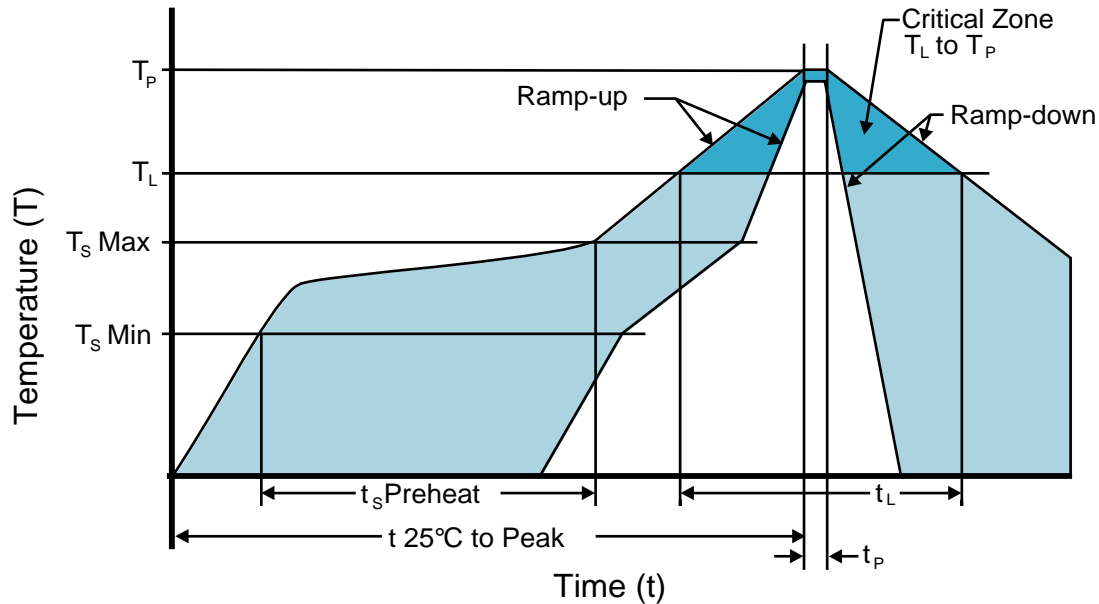

Low Temperature Infrared/Convection 240°C

| | |
|--|--|
| T_S MAX to T_L (Ramp-up Rate) | 5°C/second Maximum |
| Preheat | |
| - Temperature Minimum (T_S MIN) | N/A |
| - Temperature Typical (T_S TYP) | 150°C |
| - Temperature Maximum (T_S MAX) | N/A |
| - Time (t_S MIN) | 60 - 120 Seconds |
| Ramp-up Rate (T_L to T_P) | 5°C/second Maximum |
| Time Maintained Above: | |
| - Temperature (T_L) | 150°C |
| - Time (t_L) | 200 Seconds Maximum |
| Peak Temperature (T_P) | 240°C Maximum |
| Target Peak Temperature (T_P Target) | 240°C Maximum 2 Times / 230°C Maximum 1 Time |
| Time within 5°C of actual peak (t_P) | 10 seconds Maximum 2 Times / 80 seconds Maximum 1 Time |
| Ramp-down Rate | 5°C/second Maximum |
| Time 25°C to Peak Temperature (t) | N/A |
| Moisture Sensitivity Level | Level 1 |
| Additional Notes | Temperatures shown are applied to body of device. |

Low Temperature Manual Soldering

185°C Maximum for 10 seconds Maximum, 2 times Maximum. (Temperatures shown are applied to body of device.)

High Temperature Manual Soldering

260°C Maximum for 5 seconds Maximum, 2 times Maximum. (Temperatures shown are applied to body of device.)