

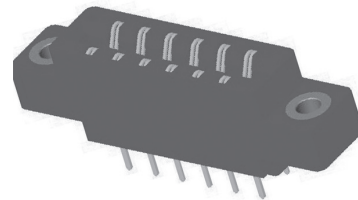

**.156" [3.96 mm] Contact Centers, .610" [15.49 mm] Insulator Height,
Dip Solder/Wire Wrap/Right Angle/Card Extender**

SPECIFICATIONS

- Accommodates $.062" \pm .008"$ [1.57 mm \pm 0.20 mm] PC board
(See following pages for $.093" \pm .008"$ [2.36 mm \pm 0.20 mm] and $.125" \pm .008"$ [3.18 mm \pm 0.20 mm] mating PCB)
- PBT, PPS or PA9T insulator
- Molded-in key available
- 3 Amps current rating for one contact energized
- 30 milli Ohms maximum at rated current
- UL Flammability Rating: 94V-0



READOUT

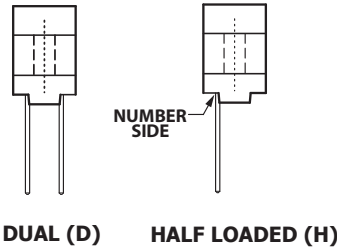

POLARIZING KEY

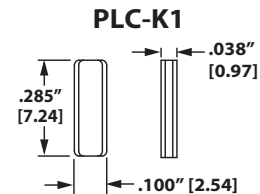

**KEY IN BETWEEN CONTACTS
(ORDER SEPARATELY)**

TERMINATION TYPE

HAIRPIN BELLOWS	TERMINATION TYPE	POST CROSS SECTION K	POST LENGTH L .025" [0.64]	FITS MIN. HOLE SIZE
CW	DIP SOLDER	.015" X .025" [0.38 X 0.64]	.125" [3.18]	.035" [0.89]
CT	DIP SOLDER	.015" X .025" [0.38 X 0.64]	.170" [4.32]	.035" [0.89]
CS	DIP SOLDER	.025" [0.64] SQUARE	.160" [4.06]	.040" [1.02]
CM	WIRE WRAP	.025" [0.64] SQUARE	.560" [14.20]	.040" [1.02]
CA	RIGHT ANGLE	.025" [0.64] SQUARE	.100" [2.54]	.043" [1.09]
CB	RIGHT ANGLE	.025" [0.64] SQUARE	.180" [4.57]	.043" [1.09]
CC	RIGHT ANGLE	.025" [0.64] SQUARE	.250" [6.35]	.043" [1.09]

HAIRPIN BELLOWS

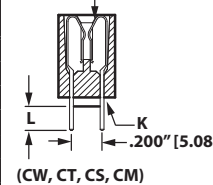

RIGHT ANGLE

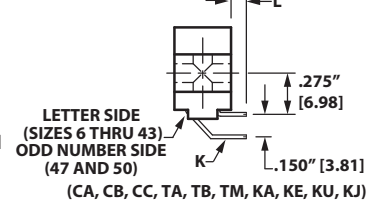

LOOP BELLOWS	TERMINATION TYPE	POST CROSS SECTION K	POST LENGTH L .025" [0.64]	FITS MIN. HOLE SIZE
TK,CK	DIP SOLDER	.025" [0.64] ROUND	.190" [4.83]	.033" [0.84]
RS	DIP SOLDER	.025" [0.64] SQUARE	.190" [4.83]	.040" [1.02]
RM	WIRE WRAP	.025" [0.64] SQUARE	.560" [14.20]	.040" [1.02]
TA	RIGHT ANGLE	.025" [0.64] SQUARE	.100" [2.54]	.043" [1.09]
TB	RIGHT ANGLE	.025" [0.64] SQUARE	.180" [4.57]	.043" [1.09]
TM	RIGHT ANGLE	.025" [0.64] SQUARE	.250" [6.35]	.043" [1.09]

LOOP BELLOWS

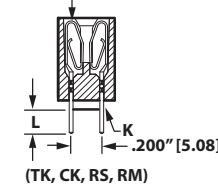

HAIRPIN or LOOP CARD EXTENDER

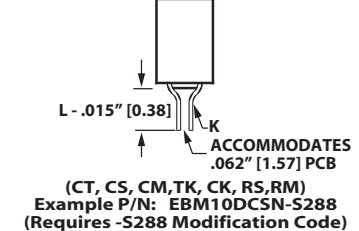

CANTILEVER	TERMINATION TYPE	POST CROSS SECTION K	POST LENGTH L .025" [0.64]	FITS MIN. HOLE SIZE
KS	DIP SOLDER	.025" [0.64] SQUARE	.190" [4.83]	.040" [1.02]
KD	DIP SOLDER	.025" [0.64] SQUARE	.160" [4.06]	.043" [1.09]
KM	WIRE WRAP	.025" [0.64] SQUARE	.560" [14.20]	.040" [1.02]
*KA	RIGHT ANGLE	.025" [0.64] SQUARE	.100" [2.54]	.043" [1.09]
*KE	RIGHT ANGLE	.025" [0.64] SQUARE	.180" [4.57]	.043" [1.09]
*KU	RIGHT ANGLE	.025" [0.64] SQUARE	.250" [6.35]	.043" [1.09]
*KJ	RIGHT ANGLE	.025" [0.64] SQUARE	.500" [12.70]	.043" [1.09]
*KR	CARD EXTENDER	.025" [0.64] SQUARE	.235" [5.97]	N/A
*KN	CARD EXTENDER	.025" [0.64] SQUARE	.605" [15.37]	N/A

CANTILEVER

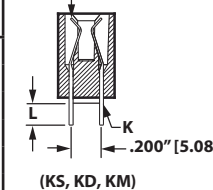

CANTILEVER CARD EXTENDER

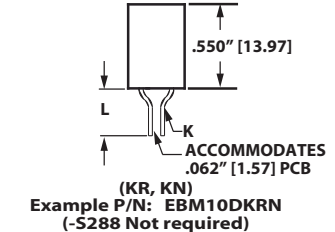

* KA, KE, KJ, KR, KN have no standoffs, unless requested.

MOUNTING STYLE

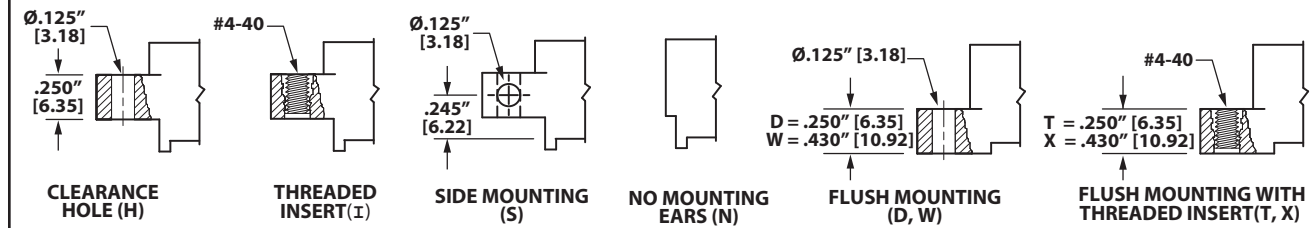



.156" [3.96 mm] Contact Centers, .610" [15.49 mm] Insulator Height, Dip Solder/Wire Wrap/Right Angle/Card Extender

Sullins Female Card Edge

PART NUMBER OPTIONS

E B M 43 D CM H - Sxxx

MATERIALS (INSULATOR/CONTACT)

E = PBT/Phosphor Bronze (Standard)
 R = PPS/Phosphor Bronze
 G = PA9T/Phosphor Bronze
 H = PBT/ Beryllium Copper
 A = PPS/Beryllium Copper
 J = PA9T/Beryllium Copper
 (Consult factory for other materials.)
 Refer to Page 7 for Operating/Processing Temperatures

CONTACT FINISH - RoHS Compliant

All platings are Lead Free and have .00050" Nickel underplate

Contact Surface	Termination
B = .000010" Gold	.000100" Pure Tin, Matte
C = .000030" Gold	.000100" Pure Tin, Matte
G = .000010" Gold	.000005" Gold
Y = .000030" Gold	.000005" Gold
Contact Surface	Overall Plating
S = .000010" Gold	.000010" Gold
M = .000030" Gold	.000010" Gold
E = .000100" Pure Tin, Matte	.000100" Pure Tin, Matte

CONTACT CENTERS

M = .156" [3.96 mm]

NUMBER OF CONTACT POSITIONS

See Chart Below

READOUT (Opposite Page)

D = Dual
 H = Half Loaded

MODIFICATION CODE (Consult Factory)

OMIT FOR STANDARD

-S189 = .200" [5.08 mm] Row Spacing on Right Angle
 -S288* = Card Extender Accepts .062" [1.57 mm] PCB
 * Not Required on KR or KN Terminations

MOUNTING STYLE (Opposite Page)

H = Clearance Holes
 I = Threaded Inserts
 S = Side Mounting
 N = No Mounting
 D, W = Flush Mounting
 T, X = Flush Mounting With Threaded Inserts

TERMINATION TYPE (Opposite Page)

Hairpin Bellows -

Available with B or C plating and Phosphor Bronze Only

CS = .025" [0.64 mm] Square Dip Solder
 CM = .025" [0.64 mm] Square Wire Wrap
 CA, CB, CC = .025" [0.64 mm] Square Right Angle
 CW, CT = .015" X .025" [0.38 mm X 0.64 mm] Dip Solder

Loop Bellows

RS = .025" [0.64 mm] Square Dip Solder
 CK, TK = .025" [0.64 mm] Round Dip Solder
 RM = .025" [0.64 mm] Square Wire Wrap
 TA, TB, TM = .025" [0.64 mm] Square Right Angle

Cantilever Bellows - Available in Y, B, or C Contact Finish Only

KS, KD = .025" [0.64 mm] Square Dip Solder
 KM = .025" [0.64 mm] Square Wire Wrap
 KA, KE, KU, KJ = .025" [0.64 mm] Square Right Angle
 KR, KN = .025" [0.64 mm] Square Card Extender

DIMENSIONS Dimensions in [] are in millimeters, all others are in inches.

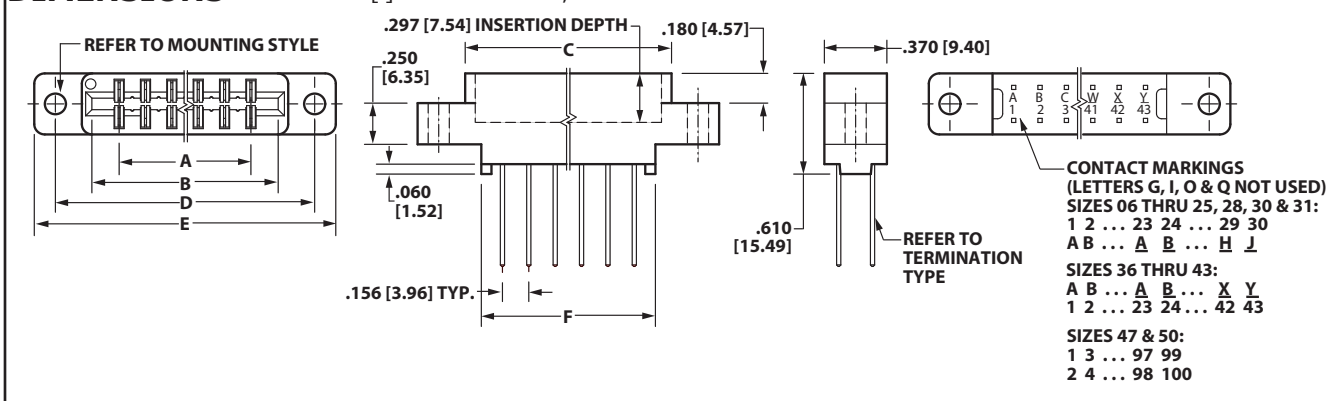

Tolerances on non-critical dimensions may vary slightly due to shrinkage differential per insulator material; Consult factory.

POSITIONS/ CONTACTS	INCHES						MILLIMETERS					
	A±.008	B±.008	C±.015	D±.010	E±.020	F±.015	A±0.20	B±0.20	C±0.38	D±0.25	E±0.51	F±0.38
06/12	0.780	1.102	1.221	1.534	1.784	1.030	19.81	27.99	31.01	38.96	45.31	26.16
08/16	1.092	1.414	1.533	1.846	2.096	1.342	27.74	35.92	38.94	46.89	53.24	34.09
10/20	1.404	1.726	1.845	2.158	2.408	1.654	35.66	43.84	46.86	54.81	61.16	42.01
12/24	1.716	2.038	2.157	2.470	2.720	1.966	43.59	51.77	54.79	62.74	69.09	49.94
15/30	2.184	2.506	2.625	2.938	3.188	2.434	55.47	63.65	66.68	74.63	80.98	61.82
18/36	2.652	2.974	3.093	3.406	3.656	2.902	67.36	75.54	78.56	86.51	92.86	73.71
20/40*	2.964	3.286	3.405	3.718	3.968	3.214	75.29	83.46	86.49	94.44	100.79	81.64
22/44	3.276	3.598	3.717	4.030	4.280	3.526	83.21	91.39	94.41	102.36	108.71	89.56
24/48	3.588	3.910	4.029	4.342	4.592	3.838	91.14	99.31	102.34	110.29	116.64	97.49
25/50	3.744	4.066	4.185	4.498	4.748	3.994	95.10	103.28	106.30	114.25	120.60	101.45
28/56	4.212	4.534	4.653	4.966	5.216	4.462	106.98	115.16	118.19	126.14	132.49	113.33
30/60	4.524	4.846	4.965	5.278	5.528	4.774	114.91	123.09	126.11	134.06	140.41	121.26
31/62	4.680	5.002	5.121	5.434	5.684	4.930	118.87	127.05	130.07	138.02	144.37	125.22
36/72	5.460	5.782	5.901	6.214	6.464	5.710	138.68	146.86	149.89	157.84	164.19	145.03
40/80	6.084	6.406	6.525	6.838	7.088	6.334	154.53	162.71	165.74	173.69	180.04	160.88
43/86	6.552	6.874	6.993	7.306	7.556	6.802	166.42	174.60	177.62	185.57	191.92	172.77
47/94	7.176	7.498	7.617	7.930	8.180	7.426	182.27	190.45	193.47	201.42	207.77	188.62
50/100	7.644	7.966	8.085	8.398	8.648	7.894	194.16	202.34	205.36	213.31	219.66	200.51

* Consult factory for availability.