

Transparent Object Detection Photoelectric Sensor E3S-DB

Superb Detection of Many Types of Transparent Objects



- Double slits inside Sensor prevent incorrect operation.
- P-opaqing function* improves detection of PET bottles and transparent films.
- Smart Teaching for optimum settings in as little as 3 seconds.
- Maximum sensing distance of 3.5 m.
- IP69K protection recommended for food and beverage industry. Third-party certification from Ecolab in Europe for detergent resistance.
- Variable connector and cable directions, and 360° indicators for greater usability.



* This function uses polarization to opaque transparent objects that exhibit double refraction.

For the most recent information on models that have been certified for safety standards, refer to your OMRON website.

Refer to the **Safety Precautions** on page 7.

Ordering Information

Sensors (Refer to *Dimensions* on page 8.)

Red light



| Sensing method | Appearance | Sensitivity adjustment | Connection method | Sensing distance *2 | Model | | | |
|--------------------------------------|------------|------------------------|--|---------------------|---------------------|-----------------------|------------------------|------------------------|
| | | | | | NPN output | PNP output | | |
| Retro-reflective (with MSR function) | | Smart Teaching | Pre-wired (2 m) | | E3S-DBN11 2M | E3S-DBP11 2M | | |
| | | | Connector (M12) | | E3S-DBN21 | E3S-DBP21 | | |
| | | | M12 Smartclick pre-wired connector (0.3 m) | | (with E39-R8) | E3S-DBN31 0.3M | E3S-DBP31 0.3M | |
| | | | Pre-wired (2 m) | | | E3S-DBN12 2M | E3S-DBP12 2M | |
| | | | Connector (M12) | | | Narrow beam | E3S-DBN22 | E3S-DBP22 |
| | | | M12 Smartclick pre-wired connector (0.3 m) | | | (with E39-R21) | E3S-DBN32 0.3M | E3S-DBP32 0.3M |
| | | Eleven-turn adjuster | Pre-wired (2 m) | | | E3S-DBN11T 2M | E3S-DBP11T 2M | |
| | | | Connector (M12) | | | E3S-DBN21T | E3S-DBP21T | |
| | | | M12 Smartclick pre-wired connector (0.3 m) | | | (with E39-R8) | E3S-DBN31T 0.3M | E3S-DBP31T 0.3M |
| | | | Pre-wired (2 m) | | | E3S-DBN12T 2M | E3S-DBP12T 2M | |
| | | | Connector (M12) | | | Narrow beam | E3S-DBN22T | E3S-DBP22T |
| | | | M12 Smartclick pre-wired connector (0.3 m) | | | (with E39-R21) | E3S-DBN32T 0.3M | E3S-DBP32T 0.3M |

*1. A Reflector is not included with the Sensor. Select a Reflector (sold separately) according to the application.

*2. There is no close-range dead zone between the Sensor and Reflector.

Accessories (Sold Separately)

Sensor I/O Connectors (Connector on One End) (A Connector is required for a Sensor with a connector or pre-wired connector.) Connectors are not provided with the Sensors. Be sure to order a Connector separately.

| Size | Cable specifications | Appearance | Cable length | Model |
|--------------------|----------------------------|--|--------------|-----------------|
| *1 M12 (4 pins) | Fire-retardant robot cable | Straight  *2 | 2 m | XS2F-D421-D80-F |
| | | | 5 m | XS2F-D421-G80-F |
| | | Straight  *2 | 2 m | XS5F-D421-D80-F |
| | | | 5 m | XS5F-D421-G80-F |

*1 Refer to your OMRON website for details on the XS2 and XS5.

*2 The connectors will not rotate after they are connected.

Reflectors (A Reflector is required for each Retro-reflective Sensor.) (Refer to Dimensions on page 10.)

Reflectors are not provided with the Sensors. Be sure to order a Reflector separately.

| Appearance | Sensing distance* (reference value) | Model | Quantity | Applicable Sensors | Remarks |
|---|-------------------------------------|----------|----------|--------------------|------------------------------|
|  | 3.5 m | E39-R1S | 1 | E3S-DB□□1(T) | Standard model |
| | 2 m | E39-R1K | | E3S-DB□□1(T) | Non-fogging reflective plate |
|  | 3 m | E39-RP1 | | E3S-DB□□1(T) | Special Polarizing Reflector |
|  | 0.5 m (rated value) | E39-R21 | | E3S-DB□□2(T) | Narrow-beam Reflector |
|  | 3.5 m (rated value) | E39-R8 | | E3S-DB□□1(T) | Standard model |
|  | 1.5 m | E39-RS10 | | E3S-DB□□1(T) | Sheets |
| | 0.5 m | | | E3S-DB□□2(T) | |
|  | 2.5 m | E39-RS11 | | E3S-DB□□1(T) | |
| | 0.5 m | | | E3S-DB□□2(T) | |



Note: 1. If you use the Reflector at any distance other than the rated distance, make sure that the stability indicator lights properly when you install the Sensor.

2. Refer to *Engineering Data (Reference Value)* on page 4 for details.

* There is no close-range dead zone between the Sensor and Reflector.

Mounting Brackets (Refer to Dimensions on page 11.)

A Mounting Bracket is not provided with the Sensor. It must be ordered separately as required.

| Type | Appearance | Model | Quantity |
|-----------------|---|----------|----------|
| Bottom-mounting |  | E39-L192 | 1 |
| Side-mounting |  | E39-L193 | |

Note: For details, refer to the *Mounting Brackets* on E39-L/E39-S/E39-R which can be accessed from your OMRON website.

Ratings and Specifications

| Item | Sensing method | | Retro-reflective (with MSR function) | | | |
|---|---|--|--------------------------------------|----------------------------|---|------------|
| | Model | NPN output | E3S-DBN□1 | E3S-DBN□1T | E3S-DBN□2 | E3S-DBN□2T |
| | | PNP output | E3S-DBP□1 | E3S-DBP□1T | E3S-DBP□2 | E3S-DBP□2T |
| Sensing distance | | 0 to 3.5 m (with E39-R8) | | | 0 to 0.5 m (with E39-R21) | |
| Spot diameter (reference value)*1 | | 6-mm dia. (at sensing distance of 250 mm) | | | 2.5-mm dia. (at sensing distance of 200 mm) | |
| Light source (wavelength) | | Red LED (624 nm) | | | | |
| Power supply voltage | | 10 to 30 VDC, including 10% ripple (p-p) | | | | |
| Power consumption | | 720 mW max. (current consumption: 30 mA max. at power supply voltage of 24 VDC) | | | | |
| Control output | | Load power supply voltage: 30 VDC max., Load current: 100 mA max. (Residual voltage: 2 V max.) Open-collector output (NPN/PNP output depending on model.) | | | | |
| Indicators | | Light indicator (orange) and stability indicator (green) | | | | |
| Protection circuits | | Reversed power supply polarity protection, output short-circuit protection, reversed output polarity protection, and mutual interference prevention | | | | |
| Response time | | Operate or reset: 0.5 ms max. | | | | |
| Sensitivity adjustment | | Smart Teaching | Eleven-turn adjuster | Smart Teaching | Eleven-turn adjuster | |
| Smart Teaching lock function | | Provided. | --- | Provided. | --- | |
| Automatic compensation (AC ³) | | Provided (OFF by default). | --- | Provided (OFF by default). | --- | |
| Ambient illumination | | (Receiver side) Incandescent lamp: 3,000 lx max., Sunlight: 10,000 lx max. | | | | |
| Ambient temperature range | | Operating: -25 to 60°C, Storage: -40 to 70°C (with no icing or condensation) | | | | |
| Ambient humidity range | | Operating: 35% to 85%, Storage: 35% to 95% (with no condensation) | | | | |
| Insulation resistance | | 20 MΩ min. (at 500 VDC) | | | | |
| Dielectric strength | | 1,000 VAC at 50/60 Hz for 1 minute | | | | |
| Vibration resistance | | Destruction: 10 to 55 Hz with double amplitude of 1.5 mm for 2 hours each in X, Y, and Z directions | | | | |
| Shock resistance | | Destruction: 500 m/s ² 3 times each in X, Y, and Z directions | | | | |
| Degree of protection*2 | | IEC IP67, DIN 40050-9 IP69K | | | | |
| Connection method | | Pre-wired cable (standard cable length: 2 m) Connector (M12, 4 pins) Pre-wired connector (standard cable length: 0.3 m/M12, 4 pins) | | | | |
| Weight (packed state/Sensor only) | Pre-wired models | Approx. 80 g/approx. 60 g | | | | |
| | Models with connector | Approx. 60 g/approx. 40 g | | | | |
| | Models with pre-wired connector | Approx. 180 g/approx. 160 g | | | | |
| Materials | Case | Polybutylene terephthalate (PBT)/ABS | | | | |
| | Lens | Methacrylic resin (PMMA) | | | | |
| | Indicators | Methacrylic resin (PMMA) | | | | |
| | Sensitivity adjuster and operation selector | Polyester elastomer | | | | |
| | Cable | Polyvinyl chloride (PVC) | | | | |
| Accessories | | Instruction manual | | | | |

*1. Refer to *Emission Spot Diameter vs. Distance in Engineering Data (Reference Value)* on page 4 for details.

*2. IP69K Degree of Protection Specification

IP69K is a protection standard against high temperature and high-pressure water defined in the German standard DIN 40050, Part 9. The test piece is sprayed with water at 80°C at a water pressure of 80 to 100 BAR using a specified nozzle shape at a rate of 14 to 16 liters/min.

The distance between the test piece and nozzle is 10 to 15 cm, and water is sprayed horizontally for 30 seconds each at 0°, 30°, 60°, and 90° while rotating the test piece on a horizontal plane.

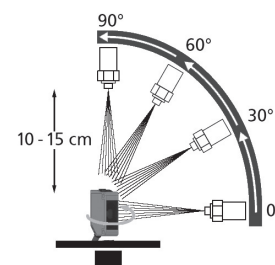

E3S-DB

Engineering Data (Reference Value)

Parallel Operating Range

E3S-DB□□1(T) + E39-R1S (Reflector)

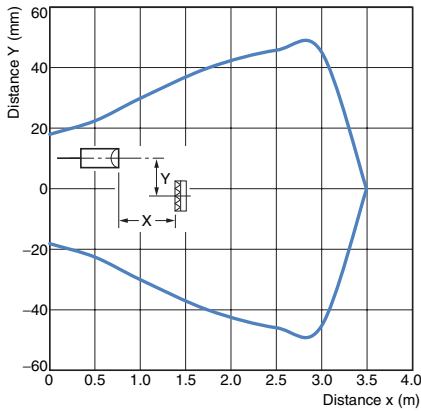

E3S-DB□□1(T) + E39-R8 (Reflector)

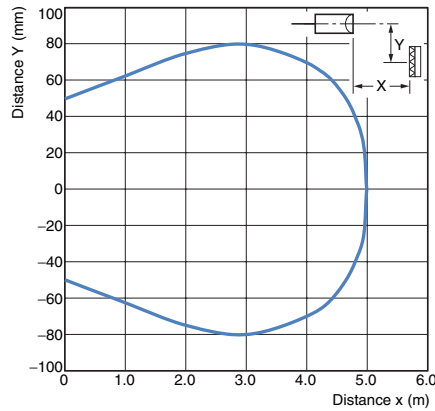

E3S-DB□□2(T) + E39-R21 (Reflector)

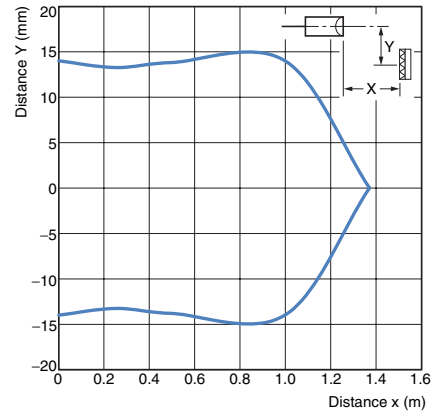

Excess Gain vs. Distance

E3S-DB□□1(T) + Reflector

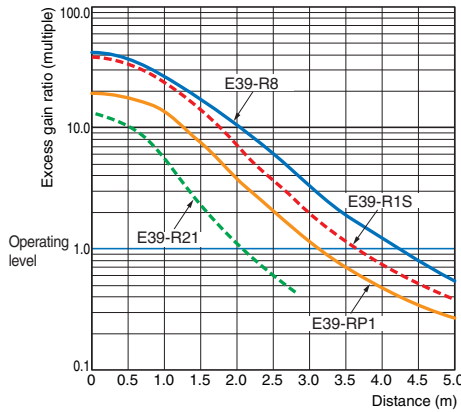

E3S-DB□□2(T) + E39-R21 (Reflector)

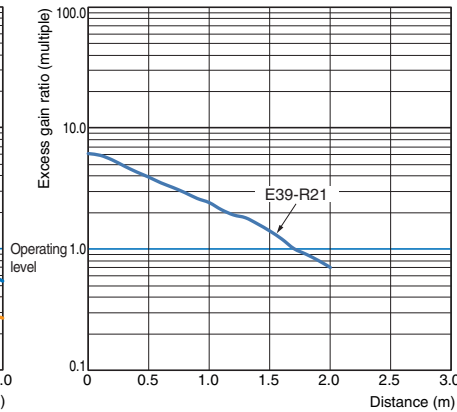

Emission Spot Diameter vs. Distance

E3S-DB□□1(T)

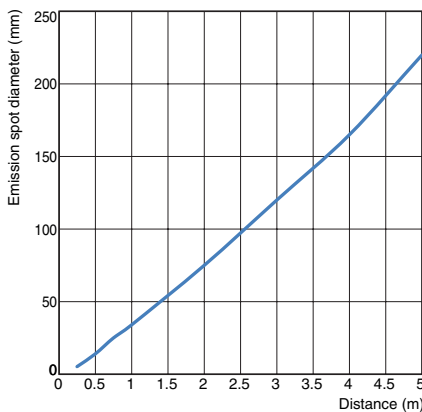

E3S-DB□□2(T)

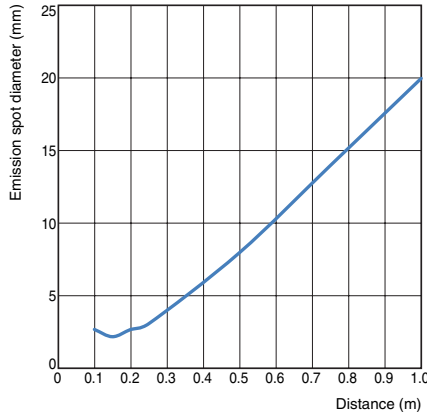

Note: These values were measured at maximum sensitivity.

Attenuation Level vs. Sensing Object Characteristics (Typical Values)

E3S-DB□□1(T) + E39-R1S/E39-R1K (Reflector) **E3S-DB□□1(T) + E39-R8 (Reflector)**

E3S-DB□□1(T) + E39-PP1 (Special Polarizing Reflector)

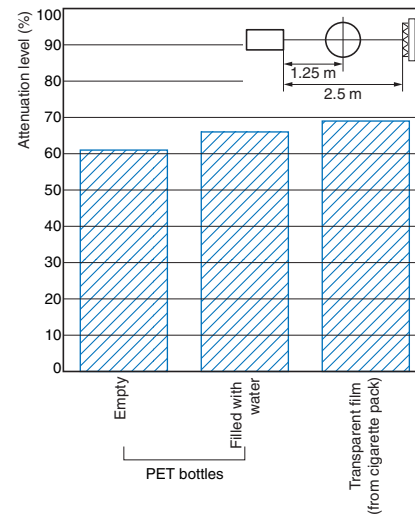
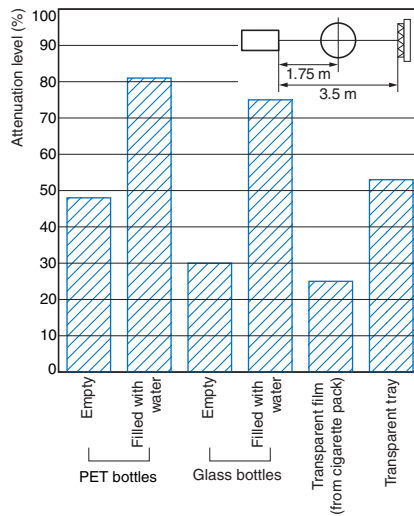
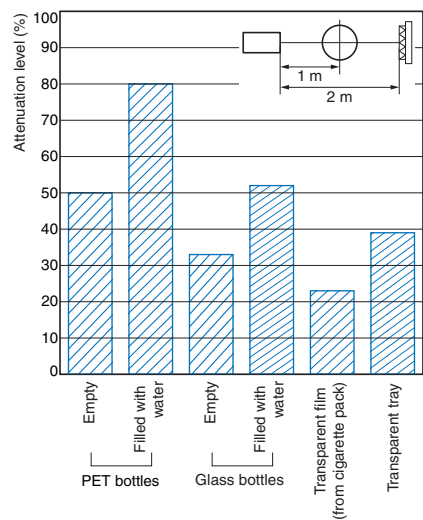

E3S-DB□□2(T) + E39-R21 (Reflector)

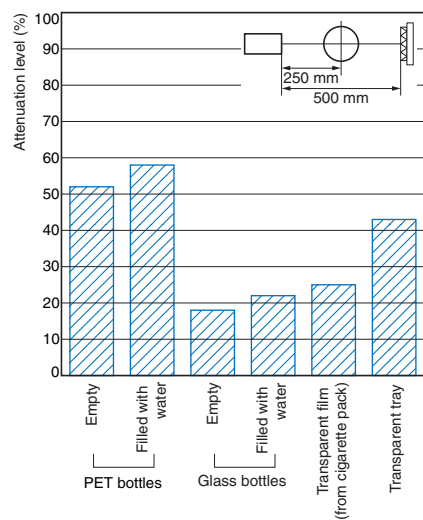

E3S-DB

I/O Circuit Diagrams

NPN Output

| Model | Operation mode | Timing charts | Output circuit |
|------------------------|----------------|--|---|
| E3S-DBN□ E3S-DBN□IT | Light ON | <p>Incident light No incident light</p> <p>Light indicator (orange) ON OFF</p> <p>Output 1 ON OFF</p> <p>Load (e.g., relay) Operate Reset</p> <p>Between brown (1) and black (4) leads</p> | <p>M12, 4-pin Connector Pin Arrangement</p> |
| | Dark ON | <p>Incident light No incident light</p> <p>Light indicator (orange) ON OFF</p> <p>Output 2 ON OFF</p> <p>Load (e.g., relay) Operate Reset</p> <p>Between brown (1) and white (2) leads</p> | |

PNP Output

| Model | Operation mode | Timing charts | Output circuit |
|------------------------|----------------|---|---|
| E3S-DBP□ E3S-DBP□IT | Light ON | <p>Incident light No incident light</p> <p>Light indicator (orange) ON OFF</p> <p>Output 1 ON OFF</p> <p>Load (e.g., relay) Operate Reset</p> <p>Between blue (3) and black (4) leads</p> | <p>M12, 4-pin Connector Pin Arrangement</p> |
| | Dark ON | <p>Incident light No incident light</p> <p>Light indicator (orange) ON OFF</p> <p>Output 2 ON OFF</p> <p>Load (e.g., relay) Operate Reset</p> <p>Between white (2) and blue (3) leads</p> | |

Connectors (Sensor I/O Connectors)

M12, 4-pin Connectors

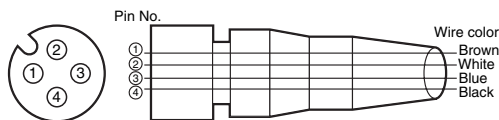

| Classification | Wire color | Pin No. | Application |
|----------------|------------|---------|---------------------|
| DC | Brown | ① | Power supply (+V) |
| | White | ② | Output 2 (Dark ON) |
| | Blue | ③ | Power supply (0 V) |
| | Black | ④ | Output 1 (Light ON) |

Nomenclature

Smart Teaching Type

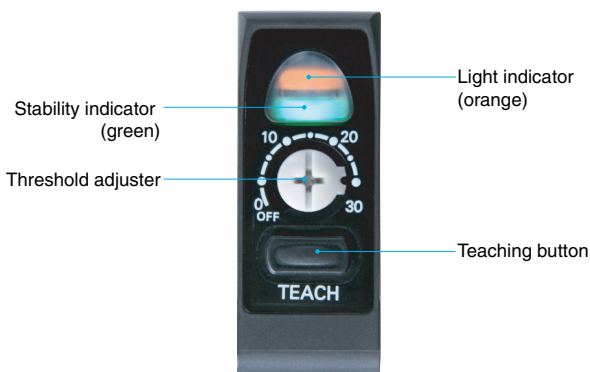

Eleven-turn Adjuster Type

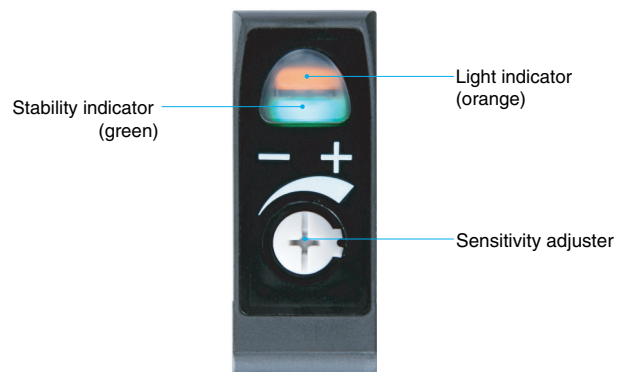

Safety Precautions

Be sure to read the precautions for all models in the website at: <http://www.ia.omron.com/>.

WARNING

Do not use the product with voltage in excess of the rated voltage.
Excess voltage may result in malfunction or fire.



Never use the product with an AC power supply.
Otherwise, explosion may result.



The maximum power supply voltage is 30 VDC.
Before turning the power ON, make sure that the power supply voltage does not exceed the maximum voltage.



Do not use the product under a chemical or an oil environment without prior evaluation.



Precautions for Safe Use

Be sure to follow the safety precautions below for added safety.

1. Do not use the product in an environment where explosive or flammable gas is present.
2. The degree of protection is IP69K, but do not use the product in water, rain, or outdoors.
3. Do not use the product in atmospheres or environments that exceed product ratings.
4. Do not use the product in locations subject to direct sunlight.
5. Do not use the product in locations subject to direct vibration or shock.
6. Do not use thinner, alcohol, or other organic solvents. Otherwise, the optical properties and degree of protection may be degraded.
7. Do not attempt to disassemble, repair, or modify the product in any way.
8. When disposing of the product, treat it as industrial waste.
9. Do not use highly concentrated cleaning agents. Otherwise, malfunction may result. Also, do not use high-pressure water with a level of pressure that exceeds the stipulated level. Otherwise, the degree of protection may be reduced.
10. Perform sensitivity adjustment with the torque of 0.06 N·m or less.
11. Do not pull on the cable with excessive strength.
12. Do not exert excessive force on the connector section.
13. This product cannot be used as a detection system to protect human bodies.
14. These Sensors are certificated for the UL standard on the assumption of usage in a Class 2 circuit. Use them with Class 2 power supplies in the United States or Canada. Use the OMRON XS2F-D4-series or XS5F-D4-series Cables. Cables that have wires less than AWG24 (0.2 mm²) are for connection to terminal blocks and are not for field splicing. External overcurrent protection of 1 A for AWG26, 2 A for AWG24, or 3 A for AWG22 wire must be provided for cable protection.

Precautions for Correct Use

1. If the Sensor wiring is placed in the same conduits or ducts as high-voltage or high-power lines, inductive noise may cause malfunction or damage. Wire the cables separately or use a shielded cable.
2. If a commercial switching regulator is used, ground the FG (frame ground) terminal.
3. The Sensor will be able to detect objects 100 ms after the power supply is turned ON. Start using the Sensor 100 ms or more after turning ON the power supply. If the load and the Sensor are connected to separate power supplies, be sure to turn ON the Sensor first.
4. Output pulses may occur when the power supply is turned OFF. We recommend that you turn OFF the power supply to the load or load line first.
5. Use M4 screws to mount the sensor and tighten each screw to a maximum torque of 1.2 N·m.

E3S-DB

Dimensions

(Unit: mm)
Tolerance class IT16 applies to dimensions in this data sheet unless otherwise specified.

Sensors

Pre-wired Models
E3S-DBN1□(T)
E3S-DBP1□(T)

Models with Pre-wired Connector
E3S-DBN3□(T)
E3S-DBP3□(T)

Smart Teaching Type

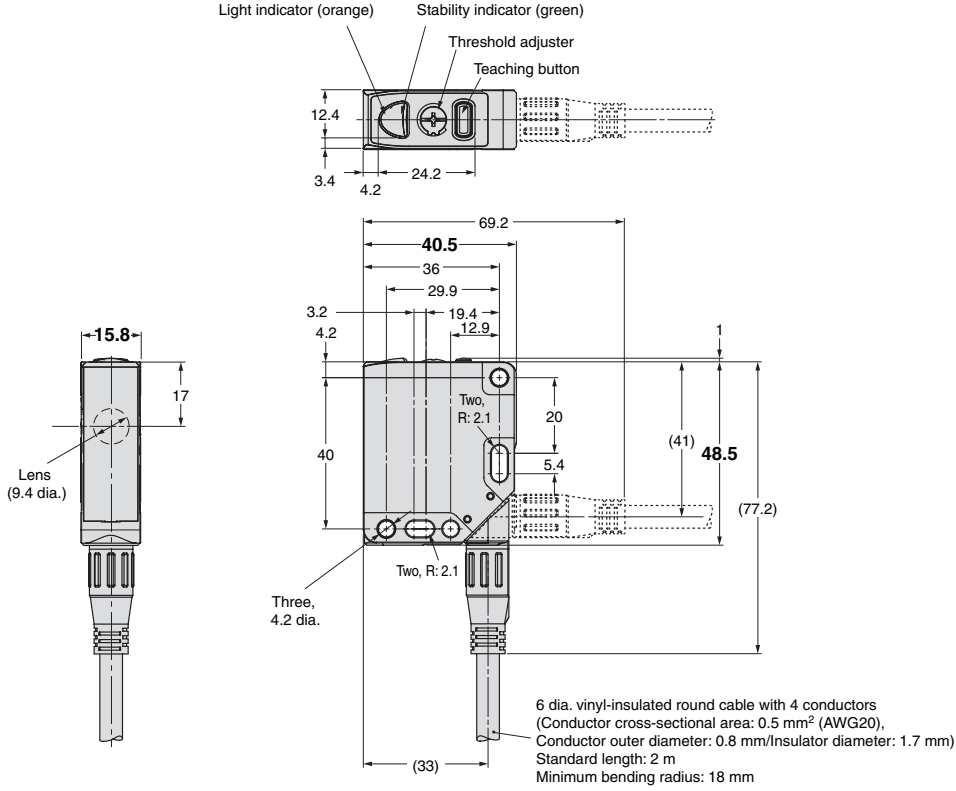

Mounting Holes

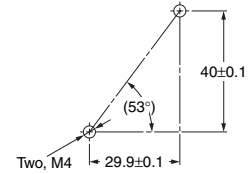

Connector on Models with Pre-wired Connector

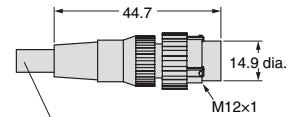

6 dia. vinyl-insulated round cable with 4 conductors (Conductor cross-sectional area: 0.5 mm² (AWG20), Conductor outer diameter: 0.8 mm/Insulator diameter: 1.7 mm)
Standard length: 0.3 m
Minimum bending radius: 18 mm

Connector Pin Arrangement



| Pin No. | Application |
|---------|---------------------|
| ① | Power supply (+V) |
| ② | Output 2 (Dark ON) |
| ③ | Power supply (0 V) |
| ④ | Output 1 (Light ON) |

Eleven-turn Adjuster Type

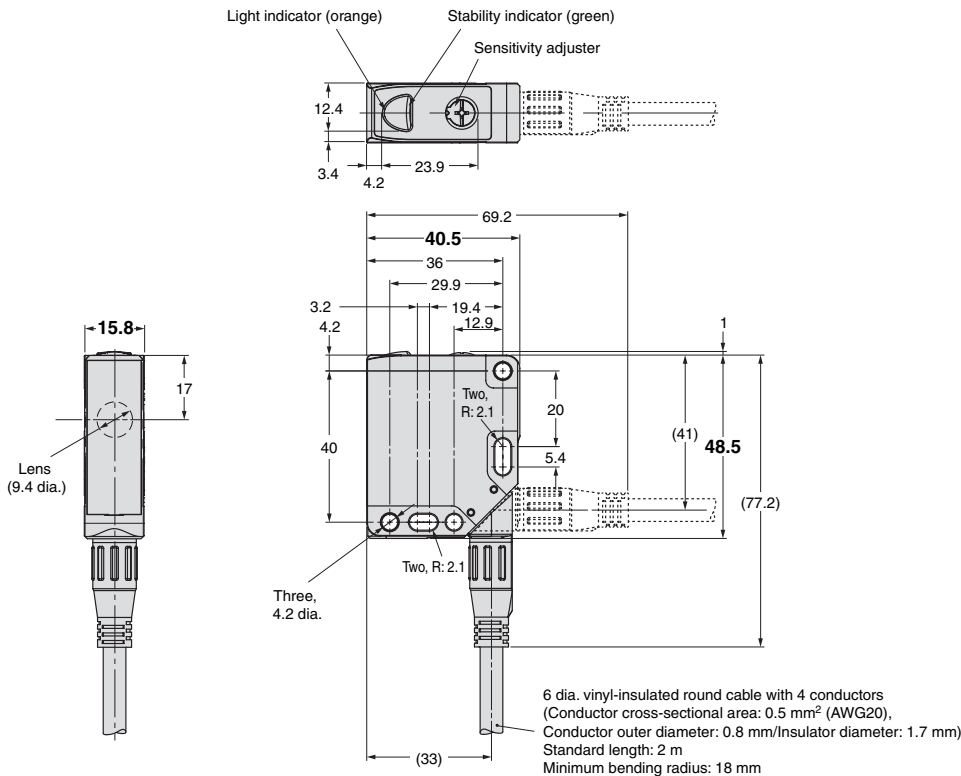

Models with M12 Connector

E3S-DBN2□(T)

E3S-DBP2□(T)

Smart Teaching Type

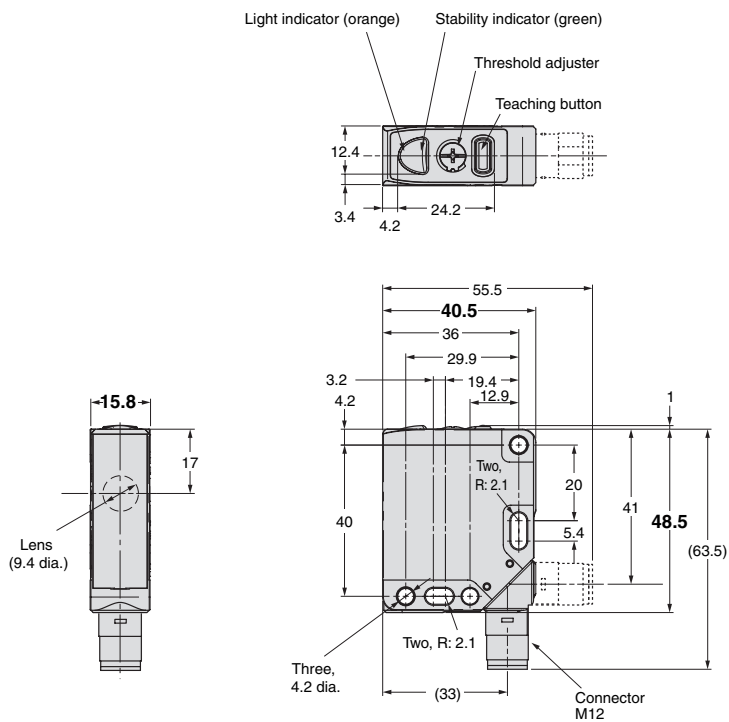

Mounting Holes

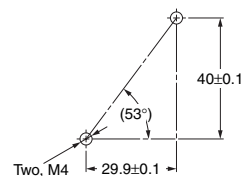

Connector Pin Arrangement



| Pin No. | Application |
|---------|---------------------|
| ① | Power supply (+V) |
| ② | Output 2 (Dark ON) |
| ③ | Power supply (0 V) |
| ④ | Output 1 (Light ON) |

Eleven-turn Adjuster Type

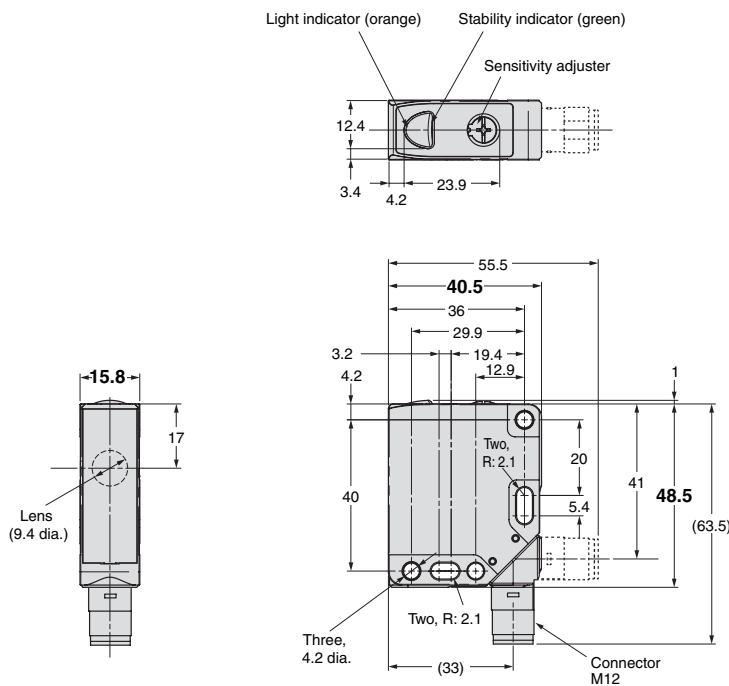

Accessories (Sold Separately)

Reflector

E39-R1S/E39-R1K*



Materials: Reflective surface: Acrylic, Rear surface: ABS
 * E39-R1K only
 Coating on reflective surface

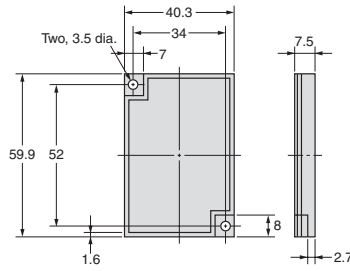

Special Polarizing Reflector

E39-RP1

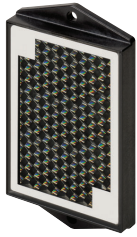

Materials: Reflective surface: Acrylic, Rear surface: ABS

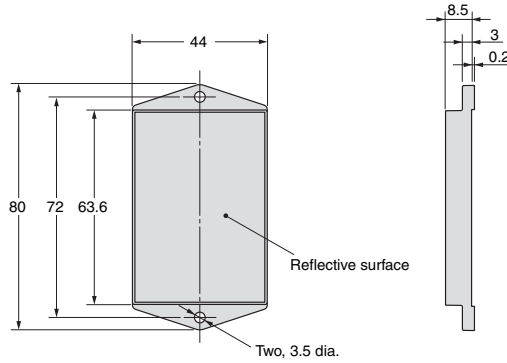

Reflector

E39-R21



Materials: Reflective surface: Methacrylic resin (PMMA),
 Rear surface: Polybutylene terephthalate (PBT)

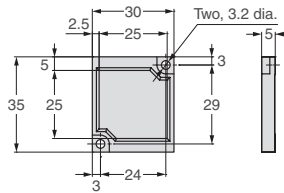

Reflector

E39-R8

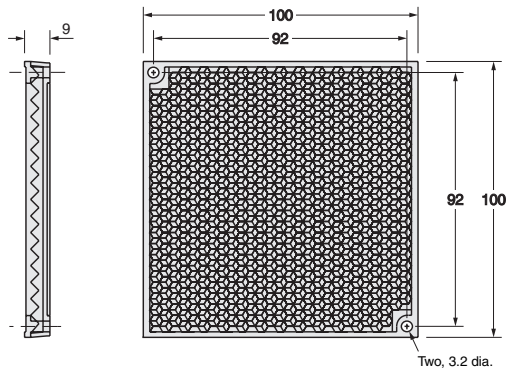
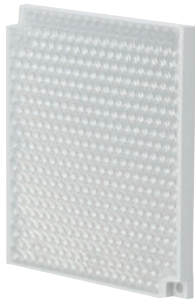

Materials: Reflective surface: Acrylic, Rear surface: ABS

Reflector

E39-RS10

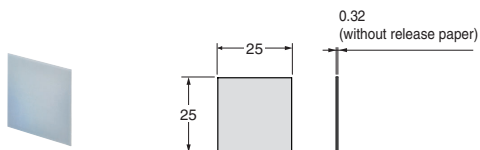

Materials: Reflective surface: Methacrylic resin (PMMA)

E39-RS11

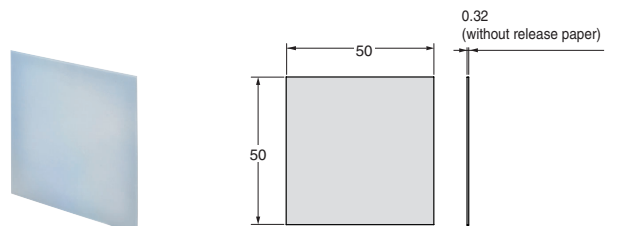

Materials: Reflective surface: Methacrylic resin (PMMA)

Mounting Brackets

E39-L192

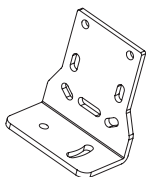

Material: SUS304

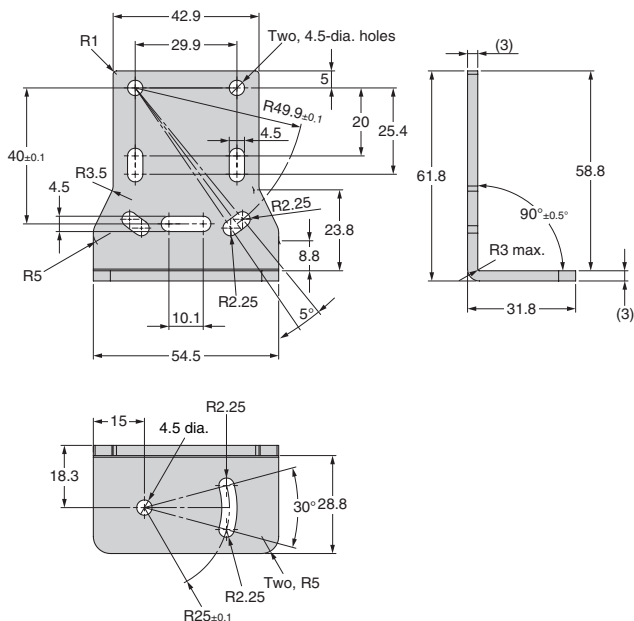

With Sensor Mounted

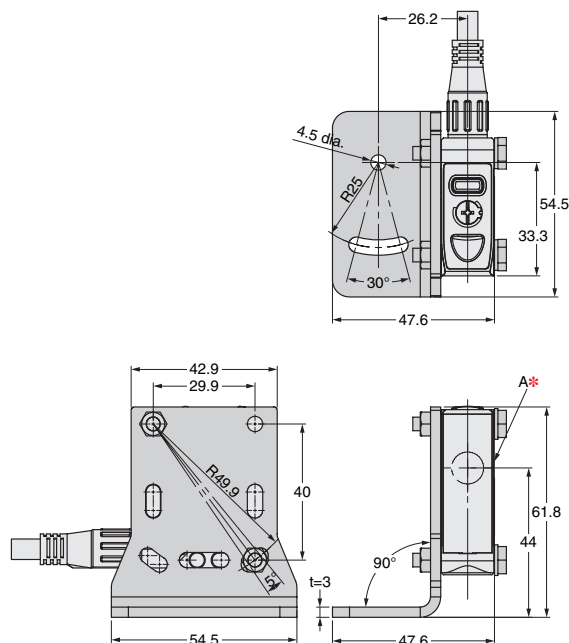

* The Mounting Bracket can be attached to side A.

E39-L193

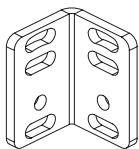

Material: SUS304

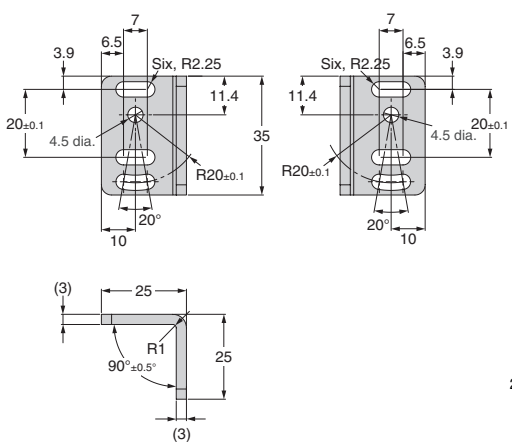

With Sensor Mounted

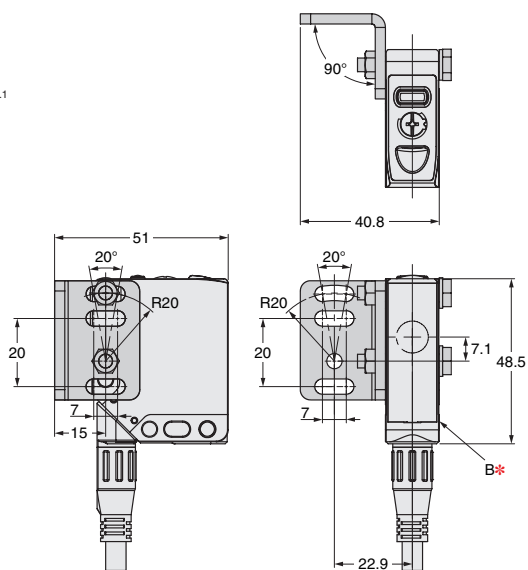

* The Mounting Bracket can be attached to side B.

Terms and Conditions Agreement

Read and understand this catalog.

Please read and understand this catalog before purchasing the products. Please consult your OMRON representative if you have any questions or comments.

Warranties.

- (a) Exclusive Warranty. Omron's exclusive warranty is that the Products will be free from defects in materials and workmanship for a period of twelve months from the date of sale by Omron (or such other period expressed in writing by Omron). Omron disclaims all other warranties, express or implied.
- (b) Limitations. OMRON MAKES NO WARRANTY OR REPRESENTATION, EXPRESS OR IMPLIED, ABOUT NON-INFRINGEMENT, MERCHANTABILITY OR FITNESS FOR A PARTICULAR PURPOSE OF THE PRODUCTS. BUYER ACKNOWLEDGES THAT IT ALONE HAS DETERMINED THAT THE PRODUCTS WILL SUITABLY MEET THE REQUIREMENTS OF THEIR INTENDED USE.

Omron further disclaims all warranties and responsibility of any type for claims or expenses based on infringement by the Products or otherwise of any intellectual property right. (c) Buyer Remedy. Omron's sole obligation hereunder shall be, at Omron's election, to (i) replace (in the form originally shipped with Buyer responsible for labor charges for removal or replacement thereof) the non-complying Product, (ii) repair the non-complying Product, or (iii) repay or credit Buyer an amount equal to the purchase price of the non-complying Product; provided that in no event shall Omron be responsible for warranty, repair, indemnity or any other claims or expenses regarding the Products unless Omron's analysis confirms that the Products were properly handled, stored, installed and maintained and not subject to contamination, abuse, misuse or inappropriate modification. Return of any Products by Buyer must be approved in writing by Omron before shipment. Omron Companies shall not be liable for the suitability or unsuitability or the results from the use of Products in combination with any electrical or electronic components, circuits, system assemblies or any other materials or substances or environments. Any advice, recommendations or information given orally or in writing, are not to be construed as an amendment or addition to the above warranty.

See <http://www.omron.com/global/> or contact your Omron representative for published information.

Limitation on Liability; Etc.

OMRON COMPANIES SHALL NOT BE LIABLE FOR SPECIAL, INDIRECT, INCIDENTAL, OR CONSEQUENTIAL DAMAGES, LOSS OF PROFITS OR PRODUCTION OR COMMERCIAL LOSS IN ANY WAY CONNECTED WITH THE PRODUCTS, WHETHER SUCH CLAIM IS BASED IN CONTRACT, WARRANTY, NEGLIGENCE OR STRICT LIABILITY.

Further, in no event shall liability of Omron Companies exceed the individual price of the Product on which liability is asserted.

Suitability of Use.

Omron Companies shall not be responsible for conformity with any standards, codes or regulations which apply to the combination of the Product in the Buyer's application or use of the Product. At Buyer's request, Omron will provide applicable third party certification documents identifying ratings and limitations of use which apply to the Product. This information by itself is not sufficient for a complete determination of the suitability of the Product in combination with the end product, machine, system, or other application or use. Buyer shall be solely responsible for determining appropriateness of the particular Product with respect to Buyer's application, product or system. Buyer shall take application responsibility in all cases.

NEVER USE THE PRODUCT FOR AN APPLICATION INVOLVING SERIOUS RISK TO LIFE OR PROPERTY OR IN LARGE QUANTITIES WITHOUT ENSURING THAT THE SYSTEM AS A WHOLE HAS BEEN DESIGNED TO ADDRESS THE RISKS, AND THAT THE OMRON PRODUCT(S) IS PROPERLY RATED AND INSTALLED FOR THE INTENDED USE WITHIN THE OVERALL EQUIPMENT OR SYSTEM.

Programmable Products.

Omron Companies shall not be responsible for the user's programming of a programmable Product, or any consequence thereof.

Performance Data.

Data presented in Omron Company websites, catalogs and other materials is provided as a guide for the user in determining suitability and does not constitute a warranty. It may represent the result of Omron's test conditions, and the user must correlate it to actual application requirements. Actual performance is subject to the Omron's Warranty and Limitations of Liability.

Change in Specifications.

Product specifications and accessories may be changed at any time based on improvements and other reasons. It is our practice to change part numbers when published ratings or features are changed, or when significant construction changes are made. However, some specifications of the Product may be changed without any notice. When in doubt, special part numbers may be assigned to fix or establish key specifications for your application. Please consult with your Omron's representative at any time to confirm actual specifications of purchased Product.

Errors and Omissions.

Information presented by Omron Companies has been checked and is believed to be accurate; however, no responsibility is assumed for clerical, typographical or proofreading errors or omissions.

OMRON Corporation **Industrial Automation Company**
Tokyo, JAPAN

Contact: www.ia.omron.com

Regional Headquarters

OMRON EUROPE B.V.

Sensor Business Unit

Carl-Benz-Str. 4, D-71154 Nufringen, Germany
Tel: (49) 7032-811-0/Fax: (49) 7032-811-199

OMRON ELECTRONICS LLC

2895 Greenspoint Parkway, Suite 200
Hoffman Estates, IL 60169 U.S.A
Tel: (1) 847-843-7900/Fax: (1) 847-843-7787

OMRON ASIA PACIFIC PTE. LTD.

No. 438A Alexandra Road # 05-05/08 (Lobby 2),
Alexandra Technopark,
Singapore 119967
Tel: (65) 6835-3011/Fax: (65) 6835-2711

OMRON (CHINA) CO., LTD.

Room 2211, Bank of China Tower,
200 Yin Cheng Zhong Road,
PuDong New Area, Shanghai, 200120, China
Tel: (86) 21-5037-2222/Fax: (86) 21-5037-2200

Authorized Distributor:

© OMRON Corporation 2015 All Rights Reserved.
In the interest of product improvement,
specifications are subject to change without notice.

CSM_1_1_0515
Cat. No. E439-E1-01

0515 (0515)