



## Product Specifications

<b>Customer</b>	<b>Standard</b>
<b>Description</b>	<b>1.44" TFT EPD Panel</b>
<b>Model Name</b>	<b>E1144CS021</b>
<b>Date</b>	<b>2015/02/02</b>
<b>Doc. No.</b>	<b>1P090-00</b>
<b>Revision</b>	<b>02</b>

<b>Customer Approval</b>	
<b>Date</b>	
<p>The above signature represents that the product specifications, testing regulation, and warranty in the specifications are accepted</p>	

	<b>Design Engineering</b>		
	<b>Approval</b>	<b>Check</b>	<b>Design</b>
			

4F, No.28, Chuangye Rd., Tainan Science Park., Tainan City 71744, Taiwan (R.O.C.)

Tel: +886-6-279-5399

Fax: +886-6-505-5300

## Copyright

Pervasive Displays Incorporated All rights reserved.

This document is the exclusive property of Pervasive Displays Inc. (PDI) and shall not be reproduced or copied or transformed to any other format without prior permission of PDI. ( PDI Confidential )

本資料為龍亭新技股份有限公司專有之財產，非經許可，不得複製、翻印或轉變成其他形式使用。

龍亭新技股份有限公司 Pervasive Displays Inc.

4F, No.28, Chuangye Rd., Tainan Science Park., Tainan City 71744, Taiwan (R.O.C.)

Tel: +886-6-279-5399

<http://www.pervasivedisplays.com>

## Table of Contents

Revision History .....	6
Glossary of Acronyms .....	7
1 General Description .....	8
1.1 Overview.....	8
1.2 Features .....	8
1.3 Applications.....	8
1.4 General Specifications .....	9
1.5 Mechanical Specifications.....	10
2 Absolute Maximum Ratings.....	12
2.1 Absolute Ratings of Environment .....	12
2.2 Reliability Test Item .....	13
3 Electrical Characteristics .....	14
3.1 Absolute Maximum Ratings of Panel .....	14
3.2 Recommended Operation Conditions of Panel .....	14
4 Application Circuit Block Diagram .....	16
5 Terminal Pin Assignment & Reference Circuit.....	17
5.1 Terminal Pin Assignment.....	17
5.2 Reference Circuit .....	19
6 Optical Characteristics .....	20
6.1 Test Conditions .....	20
6.2 Optical Specifications .....	20
6.2.1 Optical.....	20
6.2.2 Ghosting .....	23
7 Packing .....	24
8 Precautions .....	26
9 Definition of Labels.....	28

**List of Figures**

Figure 1-1 EPD Drawing..... 11

Figure 2-1 Operating Range of Relative Humidity and Temperature ..... 12

Figure 3-1 Test Pattern of Panel ..... 15

Figure 3-2 Image Update Current Profile ..... 15

Figure 3-3 Current Measurement ..... 15

Figure 4-1 Application Circuit Block Diagram..... 16

Figure 5-1 EPD Reference Circuit ..... 19

Figure 6-1 Optical measurement..... 21

Figure 6-2 Definition of Viewing Angle to Measure Contrast Ratio..... 22

Figure 7-1 Packing Diagram ..... 24

Figure 9-1 Model Labels..... 28

Figure 9-2 Definition of Model Labels ..... 28

Figure 9-3 Carton Label ..... 29

Figure 9-4 Pallet Label..... 29

**List of Tables**

Table 1-1 General Specification .....9

Table 1-2 Mechanical Specification ..... 10

Table 1-3 FPC Specification ..... 10

Table 2-1 Absolute Ratings of Environment..... 12

Table 2-2 Reliability Test Items ..... 13

Table 3-1 Absolute Maximum Ratings of Panel..... 14

Table 3-2 Recommended Operation Conditions of Panel ..... 14

Table 5-1 Terminal Pin Assignment ..... 17

Table 6-1 Optical Test Conditions ..... 20

Table 6-2 Optical Measurement with D65 light source ..... 20

Table 6-3 Measurement of Ghosting ..... 23

### Revision History

Version	Date	Page (New)	Section	Description
Ver.01	2014/11/07	All	All	Product specification first issued.
Ver.02	2015/02/02	9	1.4	Table 1-1, Add driver IC.
		20	6.2	Table 0-1 Optical Measurement with D65 light source, amend Refresh Time to 2 sec.
		28	9	Figure 9-1, Add model labels dimension and position

## Glossary of Acronyms

EPD	Electrophoretic Display (e-Paper Display)
EPD Panel	EPD
EPD Module	EPD with TCon board
TCon	Timing Controller
TFT	Thin Film Transistor
MCU	Microcontroller Unit
FPC	Flexible Printed Circuit
FPL	Front Plane Laminate
SPI	Serial Peripheral Interface
COG	Chip on Glass
PDI	Pervasive Displays Incorporated

## 1 General Description

### 1.1 Overview

This is a 1.44" a-Si, active matrix TFT, Electronic Paper Display (EPD) panel. The panel has such high resolution (111 dpi) that it is able to easily display fine patterns. Due to its bi-stable nature, the EPD panel requires very little power to update and needs no power to maintain an image.

### 1.2 Features

- a-Si TFT active matrix Electronic Paper Display(EPD)
- Resolution: 128 x 96
- Ultra low power consumption
- Super Wide Viewing Angle - near 180°
- Extra thin & light
- SPI interface
- RoHS compliant

### 1.3 Applications

- Electronic shelf label (ESL)
- Reusable container
- Badge

## 1.4 General Specifications

**Table 1-1 General Specification**

Item	Specification	Unit	Note
Outline Dimension	40.512(H) x 28.800(V) x 1.100(T)	mm	(1)
Active Area	29.312(H) x 21.984(V)	mm	
Driver Element	a-Si TFT active matrix	-	
FPL	Aurora Mb	-	
Pixel Number	128 x 96	pixel	
Pixel Pitch	0.229 x 0.229 (111dpi)	mm	
Pixel Arrangement	Vertical stripe	-	
Display Colors	Black/White	-	
Surface Treatment	Anti-Glare	-	
Driver IC	G2	-	-

Note (1): Not including the FPC.

## 1.5 Mechanical Specifications

**Table 1-2 Mechanical Specification**

Item		Min.	Typ.	Max.	Unit	Note
Glass Size	Horizontal(H)	40.21	40.51	40.81	mm	
	Vertical(V)	28.50	28.80	31.10	mm	
	Thickness(T)	1.0	1.1	1.2	mm	(1)
Weight		-	2.6	3.2	g	

Note (1): Not including the Masking Film.

**Table 1-3 FPC Specification**

Item	Pin numbers	Pitch (mm)	Connector	Note
Golden Finger	40	0.5	STARCONN 089H40 or HRS TF31-40S or Compatible	

Figure 1-1 EPD Drawing

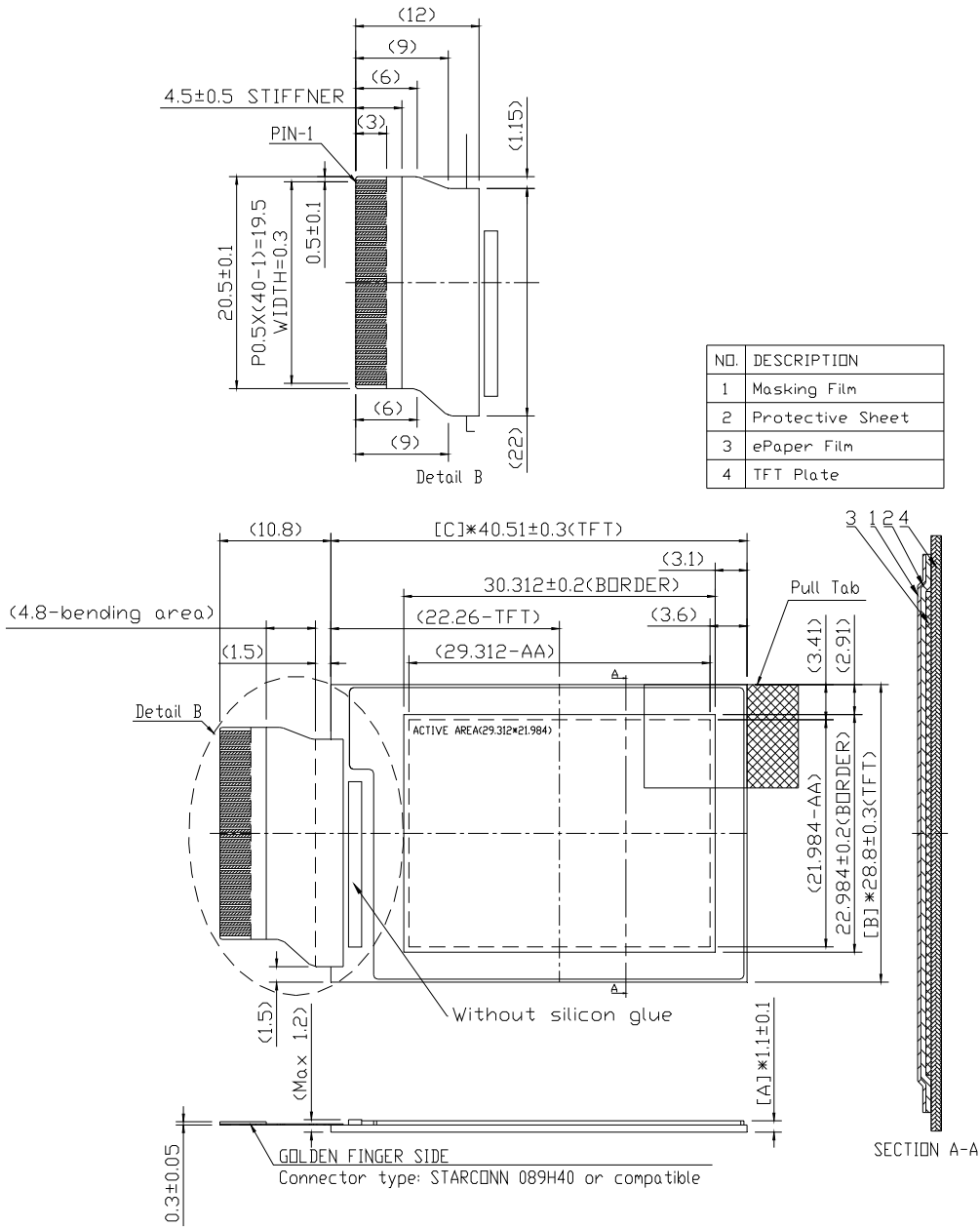

General tolerance: ±0.3mm

## 2 Absolute Maximum Ratings

### 2.1 Absolute Ratings of Environment

Table 2-1 Absolute Ratings of Environment

Item	Symbol	Value		Unit	Note
		Min.	Max.		
Storage Temperature	T <sub>ST</sub>	-20	+60	°C	(1), (3)
Operating Ambient Temperature	T <sub>OP</sub>	0	+50	°C	(1), (2), (3)

Note (1):

- (a) 90 %RH Max. ( $T_a \leq 40 \text{ }^\circ\text{C}$ ), where  $T_a$  is ambient temperature.
- (b) Wet-bulb temperature should be 39 °C Max. ( $T_a > 40 \text{ }^\circ\text{C}$ ).
- (c) No condensation and no frost.

Note (2): The temperature of panel display surface area should be 0 °C Min. and 50 °C Max. Refresh time depends on operating temperature.

Note (3): In order to keep good performance of EPD, please refer to precaution for storage condition.

Figure 2-1 Operating Range of Relative Humidity and Temperature

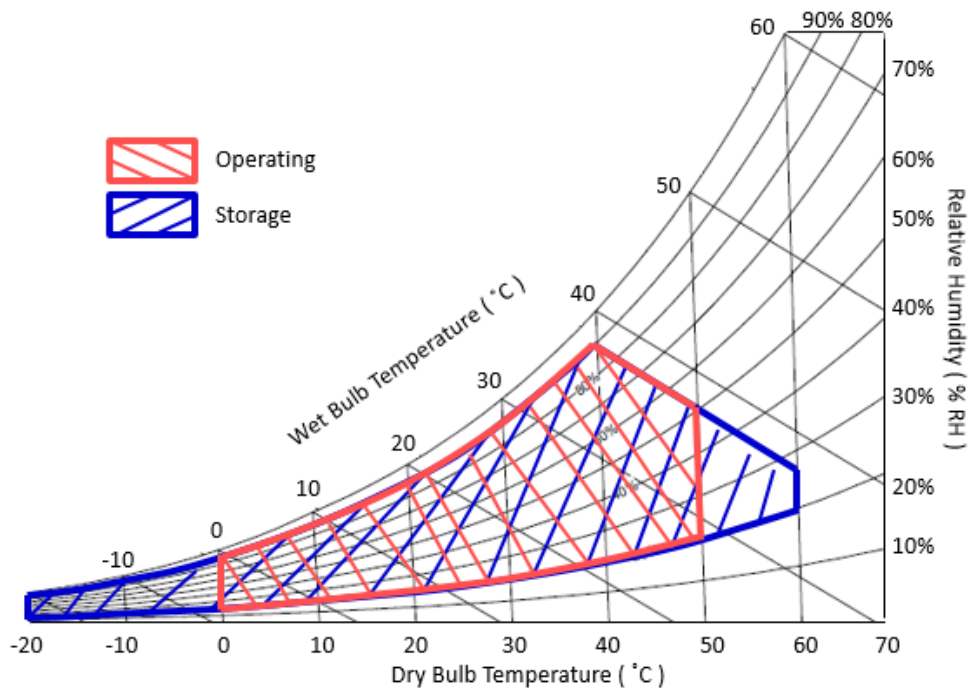

## 2.2 Reliability Test Item

**Table 2-2 Reliability Test Items**

Item	Test Condition	Remark
High Temperature Operation	50 °C / 30 %RH for 240h	(1) (2)
Low Temperature Operation	0 °C for 240h	(1) (2)
High Temperature/Humidity Operation	40 °C / 90 %RH for 168h	(1) (2)
High Temperature Storage	60 °C / 26 %RH for 240h	(1) (2)(3)
Low Temperature Storage	-20 °C for 240h	(1) (2) (3)
High Temperature/Humidity Storage	50 °C / 80 %RH for 168h	(1) (2) (3)
Thermal Cycles ( Non-operation )	1 Cycle:-20°C/30min → 60°C/30min, for 100 Cycles	(1) (2) (3)
Package Drop Test	Drop from 97cm. ( ISTA ) 1 corner, 3 edges, 6 sides. One drop for each.	(1) (2) (3)
Package Random Vibration Test	1.15Grms, 1Hz ~ 200Hz. ( ISTA )	(1) (2) (3)

Note (1): No condensation and no frost during test. End of test, function, mechanical, and optical shall be satisfied.

Note (2): The test result and judgment are based on PDI's 1bit driving waveform, driving fixture and driving system.

Note (3): Stay white pattern for storage and non-operation test.

### 3 Electrical Characteristics

#### 3.1 Absolute Maximum Ratings of Panel

**Table 3-1 Absolute Maximum Ratings of Panel**

Parameter	Symbol	Value		Unit	Note
		Min	Max		
Digital Power	$V_{DD}$	-0.3	6.0	V	
Analog Power	$V_{CC}$	-0.3	6.0	V	
Ground	$V_{SS}$	-		-	Connect $V_{SS}$ to Ground

 $T_a = 25 \pm 2 \text{ }^\circ\text{C}$ 

#### 3.2 Recommended Operation Conditions of Panel

**Table 3-2 Recommended Operation Conditions of Panel**

Parameter	Symbol	Value			Unit	Note
		Min	Typ	Max		
Digital Power	$V_{DD}$	2.3	3.0	3.6	V	
Analog Power	$V_{CC}$	2.3	3.0	3.6	V	
Input Voltage	High	$V_{IH}$	$0.8V_{DD}$	-	$V_{DD}$	/CS, ID, SCLK, SI, /RESET
	Low	$V_{IL}$	$V_{SS}$	-	$0.2V_{DD}$	
Output Voltage	High	$V_{OH}$	$0.8V_{DD}$	-	$V_{DD}$	$I_{OH}=0.5\text{mA}$ , SO, BUSY
	Low	$V_{OL}$	$V_{SS}$	-	$0.2V_{DD}$	$I_{OL}=-0.5\text{mA}$ , SO, BUSY
Input Leakage Current	High	$I_{IH}$	-	-	2.0	$\mu\text{A}$
	Low	$I_{IL}$	-	-	-2.0	$\mu\text{A}$

Input Current	$I_{DD} + I_{CC}$	-	4	8	mA	(1),(2),(3)
DC/DC Inrush Current	$I_{PEAK}$	-	30	90	mA	(1),(2),(3)

$T_a = 25 \pm 2 \text{ } ^\circ\text{C}$

Note (1):

**Figure 3-1 Test Pattern of Panel**



These currents are tested with PDI test jig.

Note (2):

$V_{DD} = V_{CC} = 3.0V$

**Figure 3-2 Image Update Current Profile**

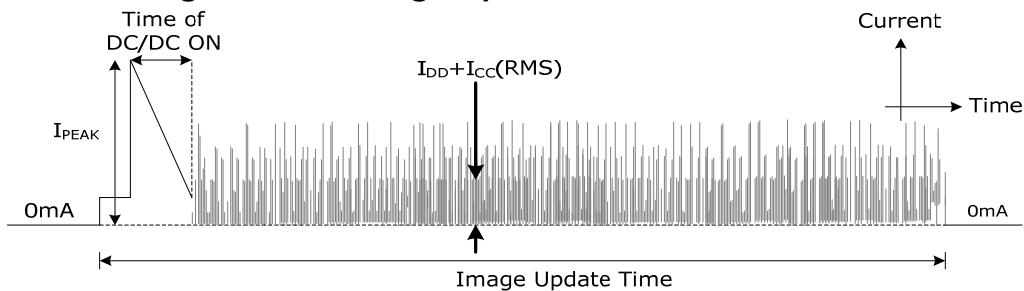

The "Time of DC/DC ON" which contains the some current peak of  $V_{GH}/V_{DH}/V_{GL}/V_{DL}/V_{COM}$ .

Note (3):

**Figure 3-3 Current Measurement**

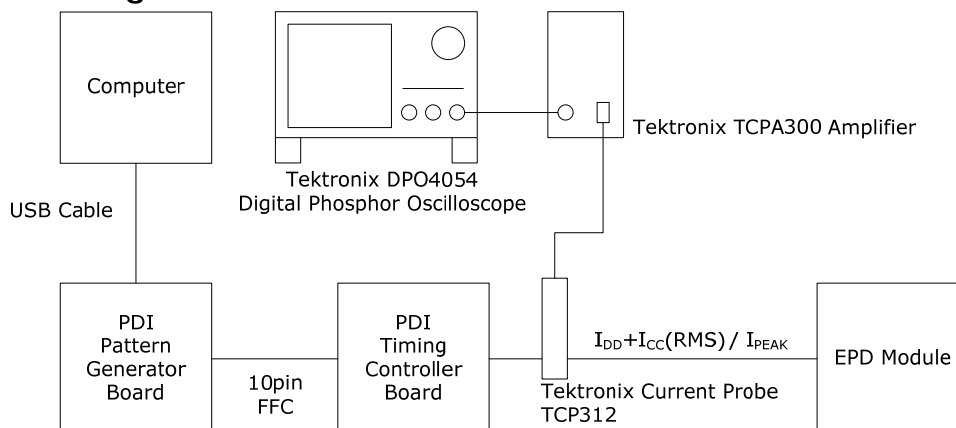

## 4 Application Circuit Block Diagram

Figure 4-1 Application Circuit Block Diagram

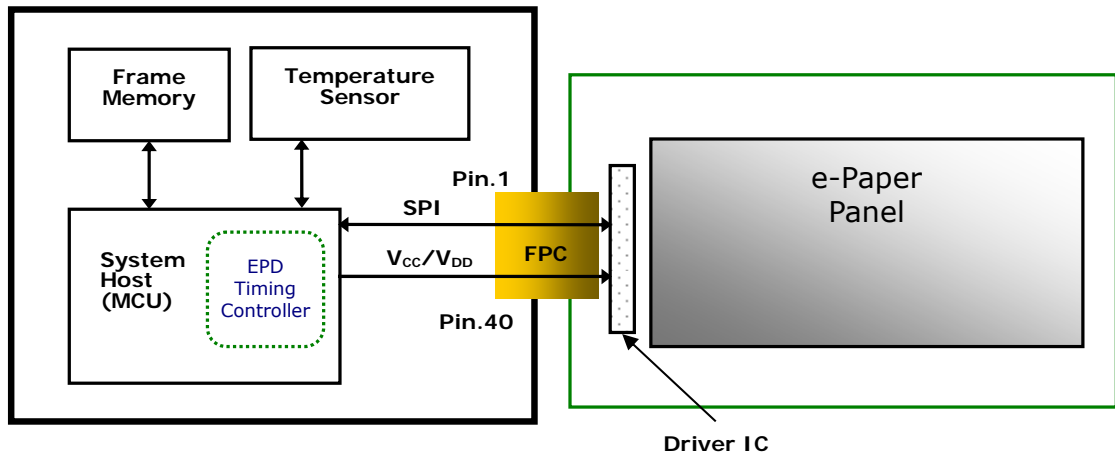

## 5 Terminal Pin Assignment & Reference Circuit

### 5.1 Terminal Pin Assignment

Table 5-1 Terminal Pin Assignment

No.	Signal	Type	Connected to	Function
1	/CS	I	Tcon	Chip Select. Low enable
2	BUSY	O	Tcon	When BUSY = HIGH, EPD stays in busy state that EPD ignores any input data from SPI
3	ID	I	Ground	Connect ID to ground
4	SCLK	I	Tcon	Clock for SPI
5	SI	I	Tcon	Serial input from Timing Controller to EPD
6	SO	O	Tcon	Serial output from EPD to Timing Controller
7	/RESET	I	Tcon	Reset signal. Low enable
8	BORDER_DRIVER	O	BORDER	Connect to BORDER
9	V <sub>CL</sub>	C	Capacitor	
10	C42P	-	NC	Not Connected
11	C42M	-		
12	C41P	C	Charge-Pump Capacitor	
13	C41M	C		
14	C31M	C	Charge-Pump Capacitor	
15	C31P	C		
16	C21M	C	Charge-Pump Capacitor	
17	C21P	C		
18	C16M	C	Charge-Pump Capacitor	
19	C16P	C		
20	C15M	C	Charge-Pump Capacitor	
21	C15P	C		

22	C14M	C	Charge-Pump Capacitor	
23	C14P	C		
24	C13M	C	Charge-Pump Capacitor	
25	C13P	C		
26	C12M	C	Charge-Pump Capacitor	
27	C12P	C		
28	C11M	C	Charge-Pump Capacitor	
29	C11P	C		
30	V <sub>COM_DRIVER</sub>	RC	Resistor & Capacitor	The signal duty cycle can drive V <sub>COM</sub> voltage from source driver IC
31	V <sub>CC</sub>	P	V <sub>CC</sub>	Power supply for analog part of source driver
32	V <sub>DD</sub>	P	V <sub>DD</sub>	Power supply for digital part of source driver
33	V <sub>SS</sub>	P	Ground	
34	V <sub>GH</sub>	C	Capacitor	
35	V <sub>GL</sub>	C	Capacitor	
36	V <sub>DH</sub>	C	Capacitor	
37	V <sub>DL</sub>	C	Capacitor	
38	BORDER	I	-	Connect to BORDER_DRIVER
39	V <sub>ST</sub>	P	V <sub>COM_PANEL</sub>	
40	V <sub>COM_PANEL</sub>	C	Capacitor	V <sub>COM</sub> to panel

**Note:**

Type: I: Input  
 O: Output  
 C: Capacitor  
 RC: Resistor and Capacitor  
 P: Power

## 5.2 Reference Circuit

Figure 5-1 EPD Reference Circuit

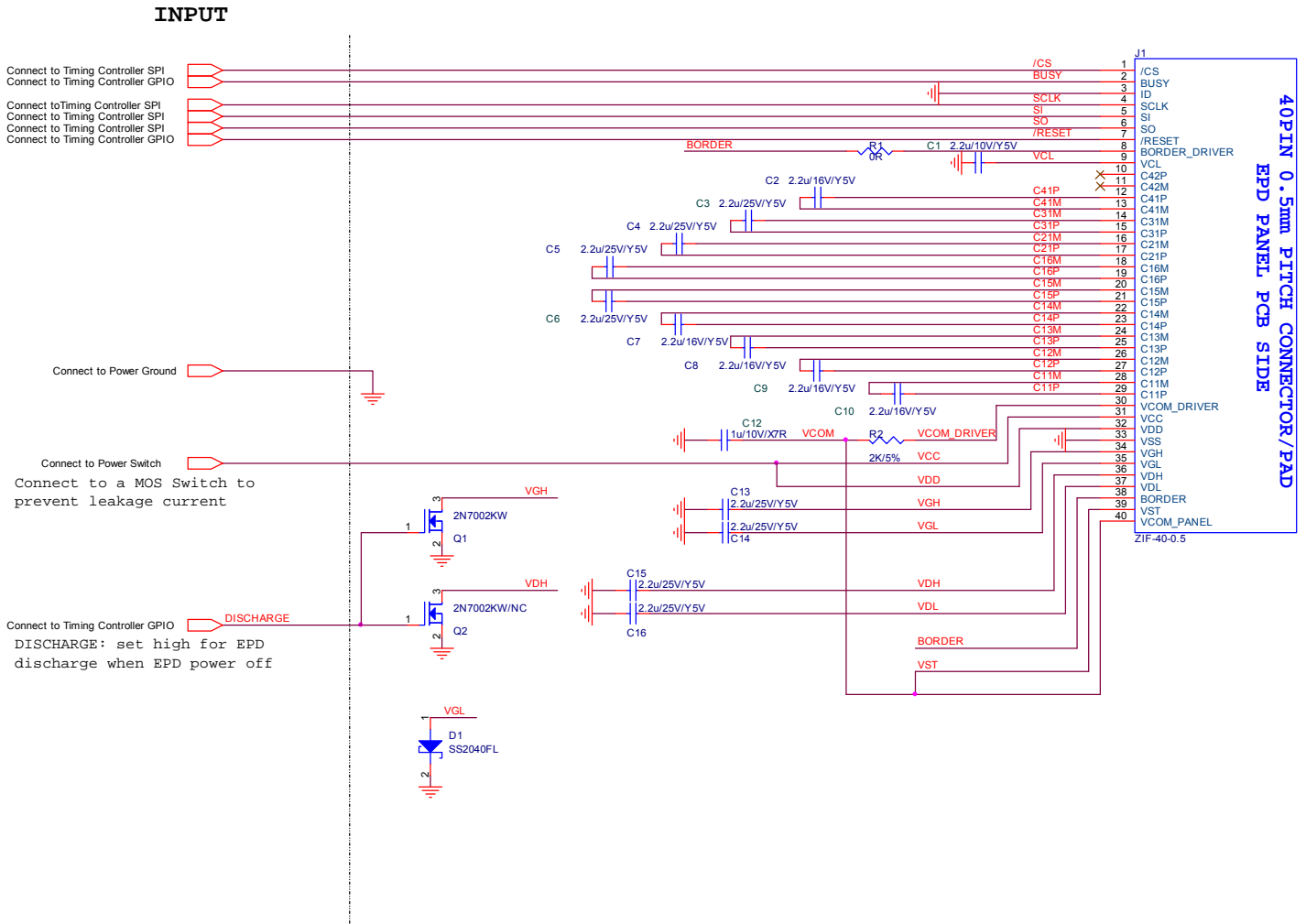

Note: (1)  $V_{DD}$  and  $V_{CC}$  must be discharged promptly after power off.

## 6 Optical Characteristics

### 6.1 Test Conditions

Table 6-1 Optical Test Conditions

Item	Symbol	Value	Unit
Ambient Temperature	Ta	25±2	°C
Ambient Humidity	Ha	50±10	%RH
Supply Voltage	V <sub>CC</sub> & V <sub>DD</sub>	3.0	V

Note: Measure optical at RT (Room Temperature) after pattern update at 25 °C.

### 6.2 Optical Specifications

#### 6.2.1 Optical

Table 6-2 Optical Measurement with D65 light source

Item	Symbol	Rating			Unit	Note
		Min.	Typ.	Max.		
Contrast ratio	CR	-	7:1	-	-	$\theta_x=\theta_y=0$ (1),(2),(3),(4)
Refresh time	Tr	-	2	-	sec	(3)
White Chromaticity	Wx	-	0.308	-	-	$\theta_x=\theta_y=0$ (1),(4)
	Wy	-	0.331	-		
Reflectance	R%	-	32	-	%	(1),(4)

Note (1): Panel is driven by PDI waveform without masking film and optical measurement by CM-700D with D65 light source and SCE mode.

Figure 6-1 Optical measurement

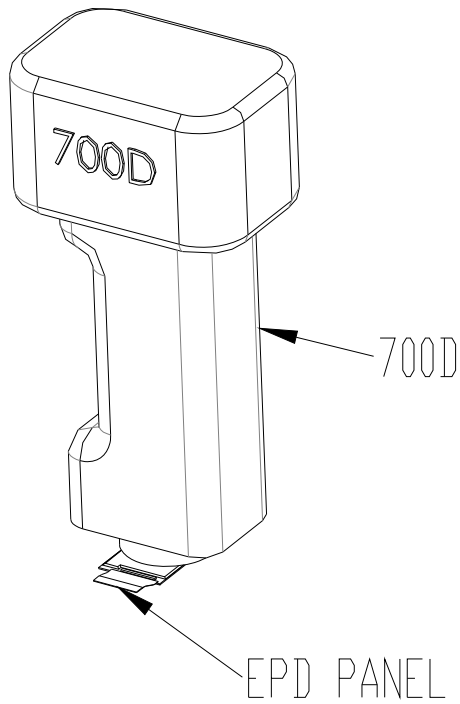

SCE mode

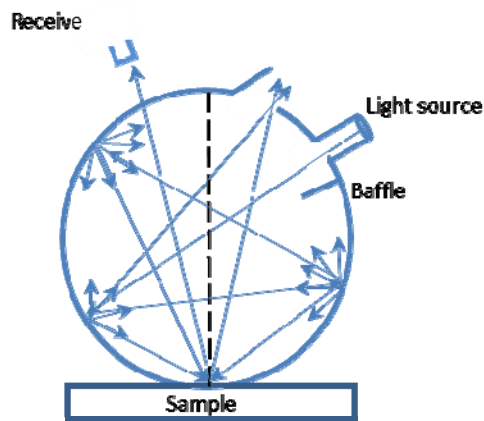



### 6.2.2 Ghosting

Below are two test methods to verify that ghosting within an acceptable range. Test 1 and Test 2 use measured data to calculate Delta E which is a single number representing the distance between two colors in a 3 dimensional color space. Test 1 and Test 2 are performed at 25°C.

- Test 1: White to Black Ghosting

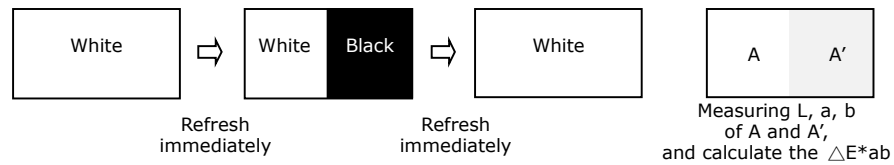

- Test 2: Black to White Ghosting

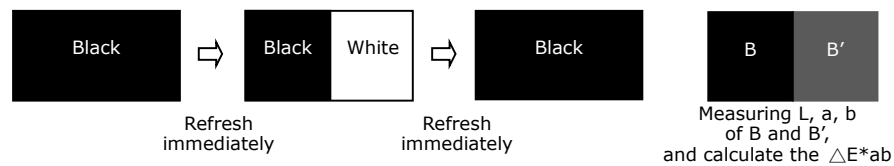

The formula is used to calculate Test1 and Test2. For example of Test 2:

$$\Delta E^*ab = [ (L_B - L_{B'})^2 + (a_B - a_{B'})^2 + (b_B - b_{B'})^2 ]^{1/2}$$

**Table 6-3 Measurement of Ghosting**

Item	Rating		
	Min.	Typ.	Max.
Test 1 ΔE*ab	-	-	2
Test 2 ΔE*ab	-	-	2

Note: Panel is driven by PDI waveform without masking film and optical measurement by CM-700D with D65 light source and SCE mode.

## 7 Packing

Figure 7-1 Packing Diagram

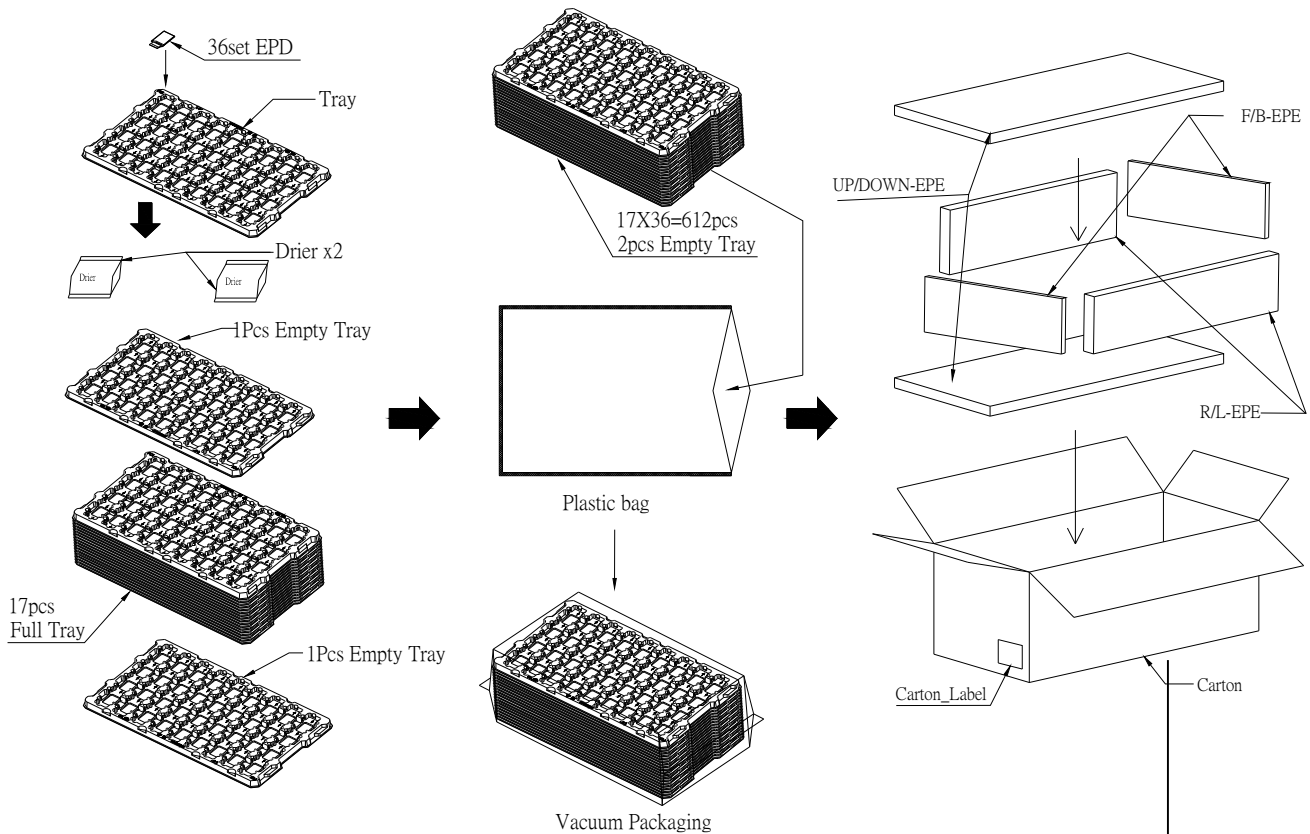

Note: 1. Carton outline size: 500L X 300W X 200H mm  
 2. Material of tray: A-PET  
 3. Material of plastic bag: PE-LD

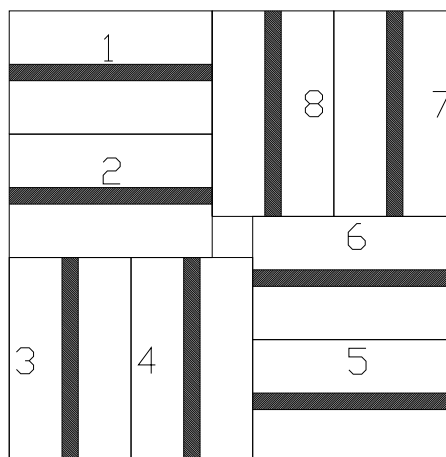

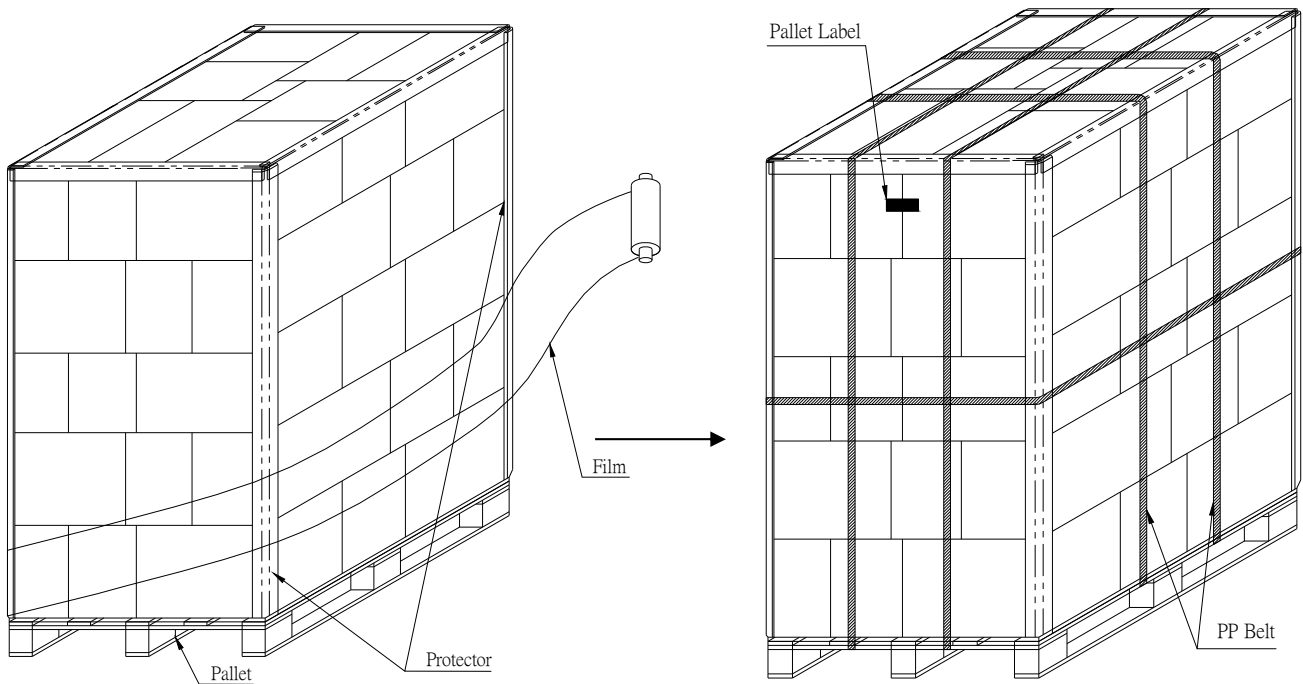

612(pcs)x40(BOX)=24480pcs

	1.44" EPD BOX
N.W. :	1.59Kg
G.W. :	4.96 Kg

### Sea / Land / Air Transportation

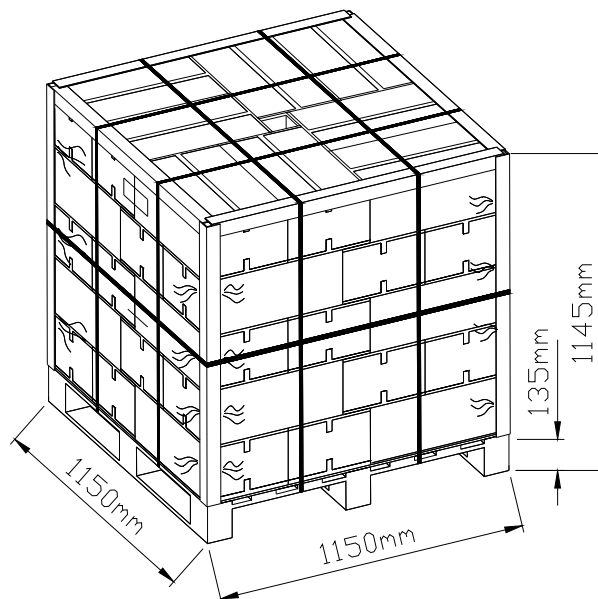

## 8 Precautions

- (1) The EPD Panel / Module is manufactured from fragile materials such as glass and plastic, and may be broken or cracked if dropped. Please handle with care. Do not apply force such as bending or twisting to the EPD panel.
- (2) It is recommended to assemble or install EPD panels in a clean working area. Dust and oil may cause electrical shorts or degrade / scratch / dent the protection sheet film.
- (3) Do not apply pressure to the EPD panel in order to prevent damaging it.
- (4) Do not connect or disconnect the interface connector while the EPD panel is in operation.
- (5) Please support as the bezel with your finger while connecting the interface cable such as the FPC.
- (6) Do not stack the EPD panels / Modules.
- (7) Do not press the FPC on the glass edge or Pull FPC up / down to 90°.
- (8) Do not touch the FPC lead connector.
- (9) Do not touch IC bonding area. It may scratch TFT lead or damage IC function.
- (10) Wear a Wrist Strap (Grounding connect) when handling and during assembly. Semiconductor devices are included in the EPD Panel / Module and they should be handled with care to prevent any electrostatic discharge (ESD). (An Ion Fan may be needed in assembly operation to reduce ESD risk.)
- (11) Keep the EPD Panel / Module in the specified environment and original packing boxes when storage in order to avoid scratching and keep original performance.
- (12) Do not disassemble or reassemble the EPD panel.
- (13) Use a soft dry cloth without chemicals for cleaning. Please don't press hard for cleaning because the surface of the protection sheet film is very soft and without hard coating. This behavior would make dent or scratch on protection sheet.
- (14) Please be mindful of moisture to avoid its penetration into the EPD panel, which may cause damage during operation.
- (15) It's low temperature operation product. Please be mindful the temperature different to make frost or dew on the surface of EPD panel. Moisture may penetrate into the EPD panel because of frost or dew on surface of EPD panel, and makes EPD panel damage.
- (16) High temperature, high humidity, sunlight or fluorescent light may degrade the EPD panel's performance. Please do not expose the unprotected EPD panel to high temperature, high humidity, sunlight, or fluorescent for long periods of time. Please store the EPD panel in controllable environment of warehouse and original package: Without sunlight, without condensation, a temperature range of 15°C to 35°C, and humidity from 30%RH to 60%RH.
- (17) The label ink used for marking the Panel ID number is erased easily by solvent. Please avoid using solvent to clean the EPD panel.
- (18) The EPD is vacuum packed.

- (19) Before approved by PDI and customer, products and product specifications may be subject to change without notice. Confirm that you have received the latest product standards or specifications before final design, purchase or use.
- (20) PDI makes every attempt to ensure that its products are of high quality and reliability. However, contact PDI sales office before using the product in an application that demands especially high quality and reliability or where its failure or malfunction may directly threaten human life or cause risk of bodily injury, such as aerospace, aeronautics, nuclear power, combustion control, transportation, traffic, safety equipment or medical equipment for life support.
- (21) Design your application so that the product is used within the ranges guaranteed by PDI particularly for maximum rating, operating supply voltage range, heat radiation characteristics, installation conditions and other characteristics. PDI bears no responsibility for failure or damage when used beyond the guaranteed ranges. Even within the guaranteed ranges, consider normally foreseeable failure rates or failure modes in semiconductor devices and employ systemic measures such as fail safes, so that the equipment incorporating PDI product does not cause bodily injury, fire or other consequential damage due to operation of the PDI product.
- (22) This product is not designed to be radiation resistant.

## 9 Definition of Labels

Figure 9-1 Model Labels

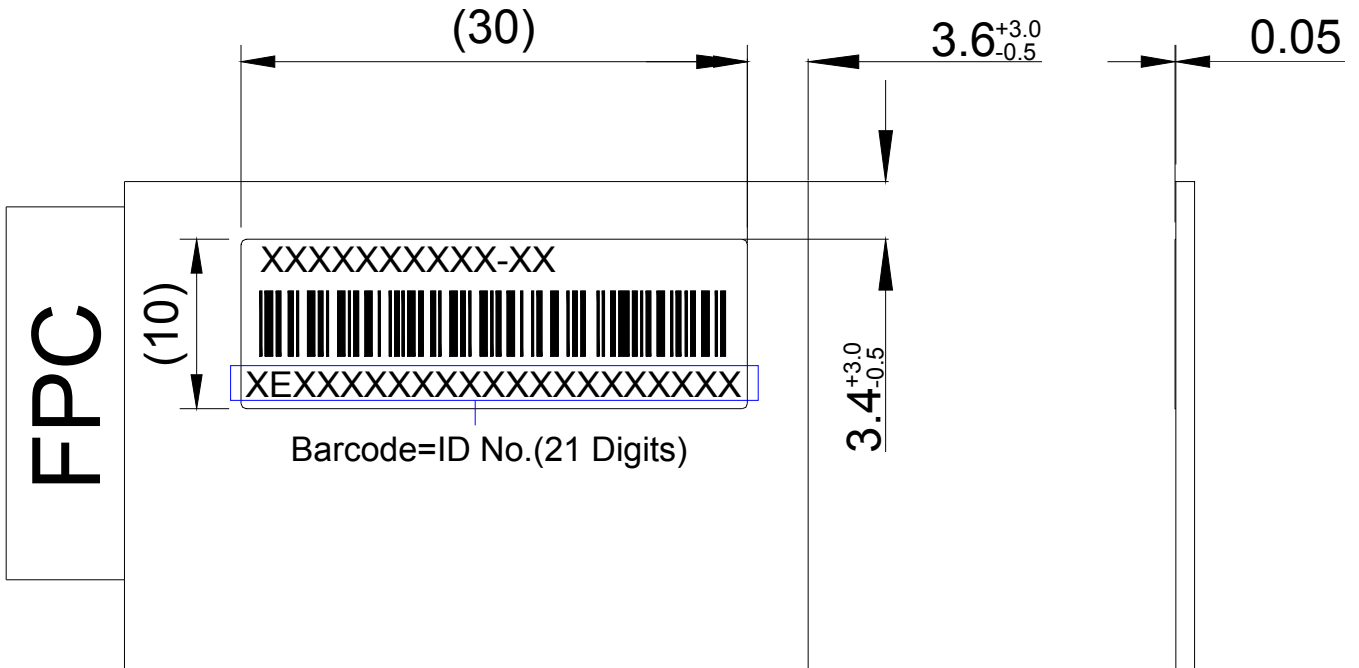

Figure 9-2 Definition of Model Labels

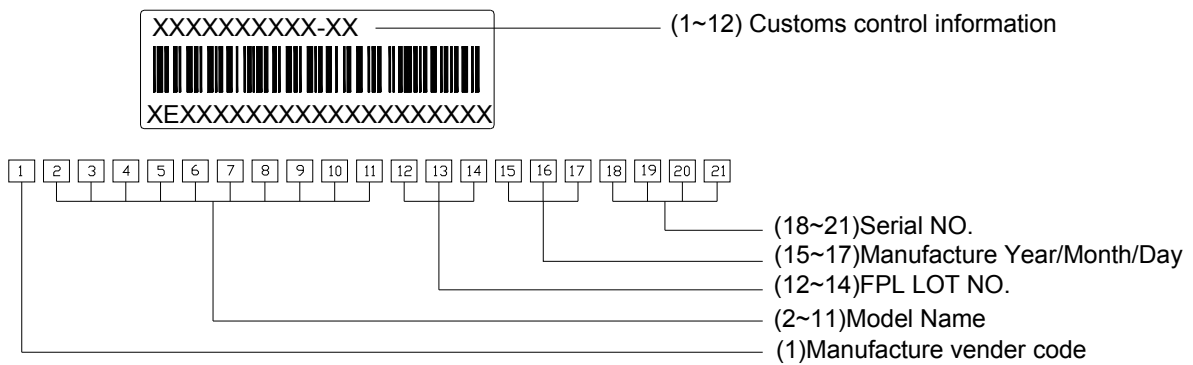
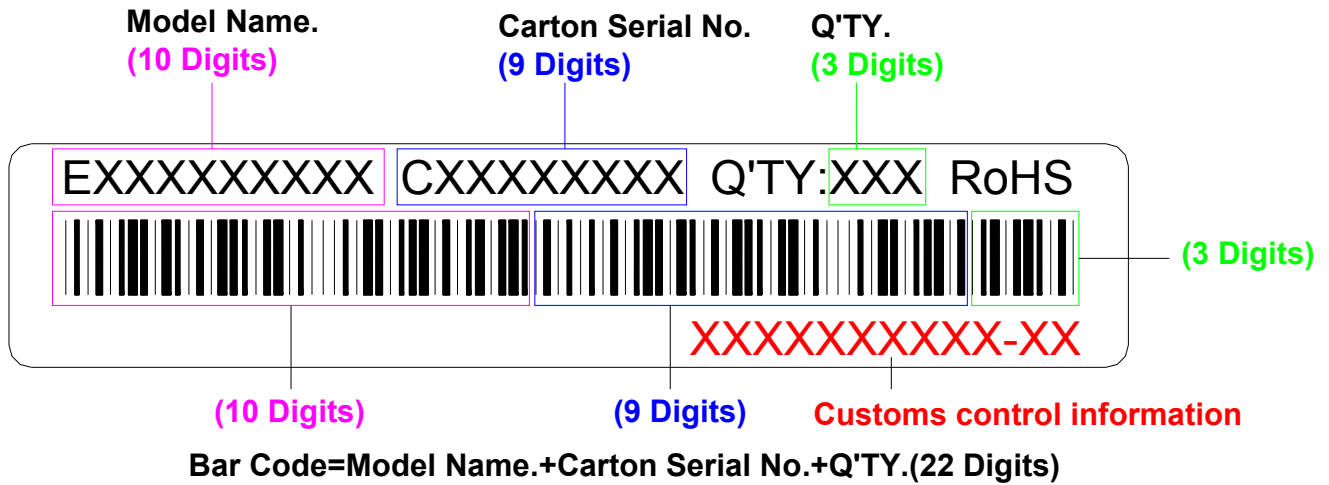

Figure 9-3 Carton Label



# Carton Label

Figure 9-4 Pallet Label



Bar Code=Model Name.+Pallet Serial No.+Q'TY.(22 Digits)

# Pallet Label