

DS89C386 Twelve Channel CMOS Differential Line Receiver

Check for Samples: [DS89C386](#)

FEATURES

- **Low Power Design—240 mW Typical**
- **Meets TIA/EIA-422-B (RS-422)**
- **Receiver OPEN Input Failsafe Feature**
- **Ensured AC Parameters:**
 - **Maximum Receiver Skew –4 ns**
 - **Maximum Transition Time –9 ns**
- **High Output Drive Capability: ±6 mA**
- **Available in SSOP Packaging:**
 - **Requires 30% less PCB Space than 3 DS34C86TMs**

DESCRIPTION

The DS89C386 is a high speed twelve channel CMOS differential receiver that meets the requirements of TIA/EIA-422-B. The DS89C386 features low power dissipation of 240 mW typical.

Each TRI-STATE enable, EN, allows the receiver output to be active or in a Hi-impedance off state. Each enable is common to only two receivers for flexibility and multiplexing of receiver outputs.

The receiver output (RO) is ensured to be High when the inputs are left open and unterminated. The receiver can detect signals as low and including ±200 mV over the common mode range of ±7V. The receiver outputs (RO) are compatible with both TTL and CMOS levels.

Connection Diagrams

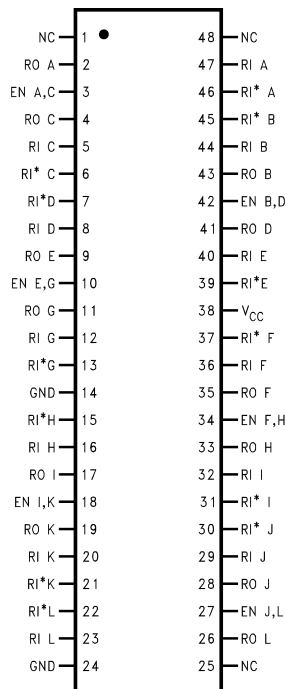
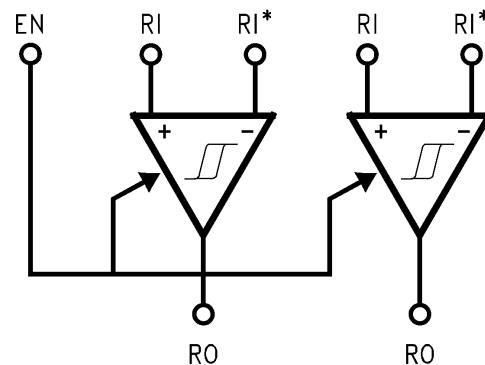

Figure 1. 48-Pin SSOP
See Package Number DL0048A



1/6 of package

Figure 2. Function Diagram

Truth Table (1)

Enable	Inputs	Output
EN	RI–RI*	RO
L	X	Z
H	≥200 mV or OPEN ⁽¹⁾	H
H	≤ –200 mV	L
H	+200 mV > and > –200 mV	X

(1) Not terminated.



These devices have limited built-in ESD protection. The leads should be shorted together or the device placed in conductive foam during storage or handling to prevent electrostatic damage to the MOS gates.



Please be aware that an important notice concerning availability, standard warranty, and use in critical applications of Texas Instruments semiconductor products and disclaimers thereto appears at the end of this data sheet.

All trademarks are the property of their respective owners.

Absolute Maximum Ratings⁽¹⁾⁽²⁾⁽³⁾

Supply Voltage (V_{CC})	-0.5 to 7V
Input Common Mode Range (V_{CM})	$\pm 14V$
Differential Input Voltage (V_{DIFF})	$\pm 14V$
Enable Input Voltage (V_{IN})	7V
Storage Temperature Range (T_{STG})	-65°C to +150°C
Lead Temperature (Soldering 4 sec)	260°C
Maximum Power Dissipation at 25°C ⁽⁴⁾	
SSOP Package	1359 mW
Current Per Output	± 25 mA
This device does not meet 2000V ESD rating. ⁽⁵⁾	

- (1) Unless otherwise specified, all voltages are referenced to ground.
(2) Absolute Maximum Ratings are those values beyond which the safety of the device cannot be specified. They are not meant to imply that the device should be operated at these limits. The table of "Electrical Characteristics" provides conditions for actual device operation.
(3) If Military/Aerospace specified devices are required, please contact the Texas Instruments Sales Office/ Distributors for availability and specifications.
(4) Ratings apply to ambient temperature at 25°C. Above this temperature derate SSOP (MEA) Package 10.9 mW/°C.
(5) ESD Rating: HEM (1.5 k Ω , 100 pF) Inputs \geq 2000V Outputs \geq 1000V EIAJ (0 Ω , 200 pF) All Pins \geq 350V

Operating Conditions

	Min	Max	Unit
Supply Voltage (V_{CC})	4.50	5.50	V
Operating Temperature Range (T_A)			
DS89C386T	-40	+85	°C
Enable Input Rise or Fall Times		500	ns

DC Electrical Characteristics⁽¹⁾

$V_{CC} = 5V \pm 10\%$ (unless otherwise specified)

Parameter		Test Conditions	Min	Typ	Max	Units
V_{TH}	Differential Input Voltage	$V_{OUT} = V_{OH}$ or V_{OL} $-7V < V_{CM} < +7V$	-200	± 35	+200	mV
V_{HYST}	Input Hysteresis	$V_{CM} = 0V$		70		mV
R_{IN}	Input Resistance	$V_{IN} = -7V, +7V$ (Other Input = GND)	5.0	6.8	10	k Ω
I_{IN}	Input Current (Under Test)	$V_{IN} = +10V$, Other Input = GND		+1.1	+1.5	mA
		$V_{IN} = -10V$, Other Input = GND		-2.0	-2.5	mA
V_{OH}	High Level Output Voltage	$V_{CC} = \text{Min.}$, $V_{(DIFF)} = +1V$ $I_{OUT} = -6.0$ mA	3.8	4.2		V
V_{OL}	Low Level Output Voltage	$V_{CC} = \text{Max.}$, $V_{(DIFF)} = -1V$ $I_{OUT} = 6.0$ mA		0.2	0.3	V
V_{IH}	Enable High Input Level Voltage		2.0		V_{CC}	V
V_{IL}	Enable Low Input Level Voltage		GND		0.8	V
I_{OZ}	TRI-STATE Output Leakage Current	$V_{OUT} = V_{CC}$ or GND, EN = V_{IL}		± 0.5	± 5.0	μA
I_I	Enable Input Current	$V_{IN} = V_{CC}$ or GND			± 1.0	μA
I_{CC}	Quiescent Power Supply Current	$V_{CC} = \text{Max.}$, $V_{(DIFF)} = +1V$		48	69	mA

- (1) Unless otherwise specified, Min/Max limits apply across the operating temperature range. All typicals are given for $V_{CC} = 5V$ and $T_A = 25^\circ C$.

AC Electrical Characteristics⁽¹⁾

V_{CC} = 5V ±10% (Figure 3, Figure 4, and Figure 5)

Parameter		Test Conditions	Min	Typ	Max	Units
t _{PLH} , t _{PHL}	Propagation Delay Input to Output	C _L = 50 pF V _{DIFF} = 2.5V V _{CM} = 0V	10	19	30	ns
t _{SK}	Skew	C _L = 50 pF V _{DIFF} = 2.5V V _{CM} = 0V	0	2	4	ns
t _{RISE} , t _{FALL}	Output Rise and Fall Times	C _L = 50 pF V _{DIFF} = 2.5V V _{CM} = 0V		4	9	ns
t _{PLZ} , t _{PHZ}	Propagation Delay ENABLE to Output	C _L = 50 pF R _L = 1000Ω V _{DIFF} = 2.5V		13	18	ns
t _{PZL} , t _{PZH}	Propagation Delay ENABLE to Output	C _L = 50 pF R _L = 1000Ω V _{DIFF} = 2.5V		13	21	ns

(1) Unless otherwise specified, Min/Max limits apply across the operating temperature range. All typicals are given for V_{CC} = 5V and T_A = 25°C.

Logic Diagram

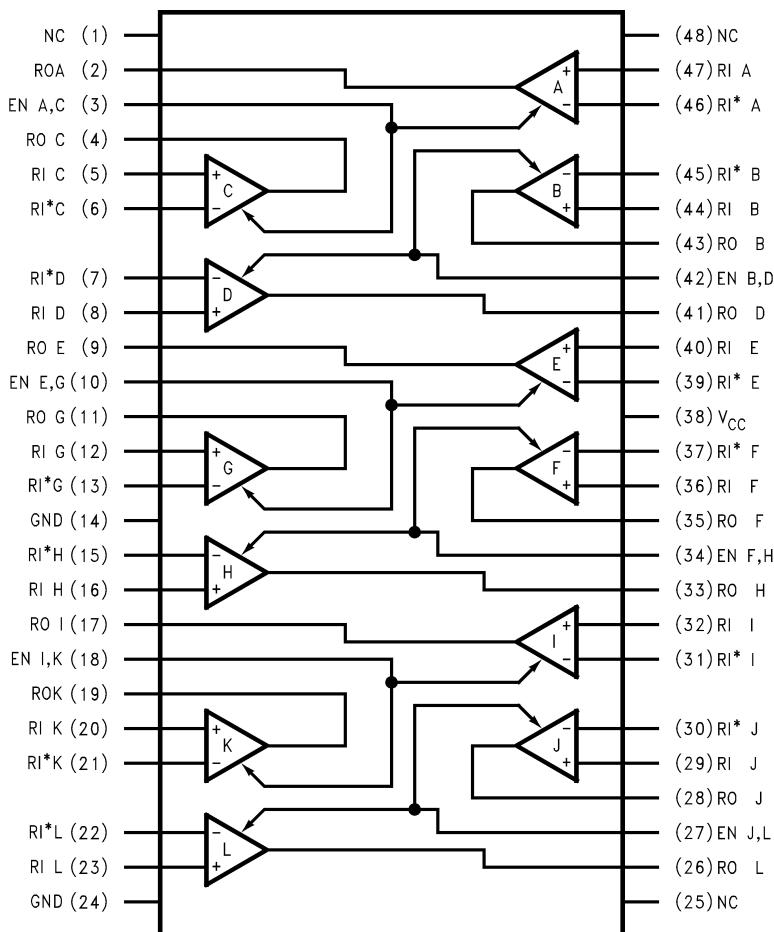

Parameter Measurement Information

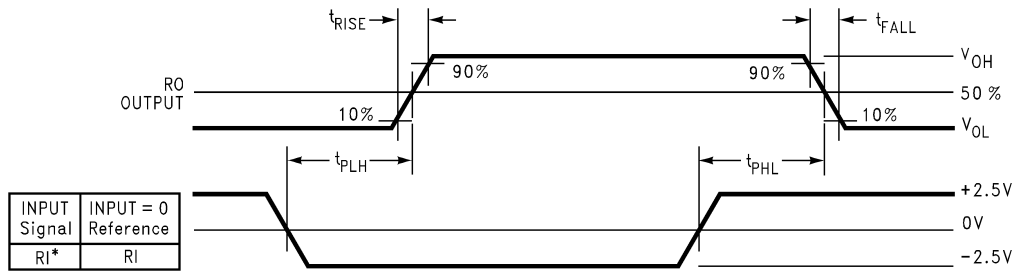
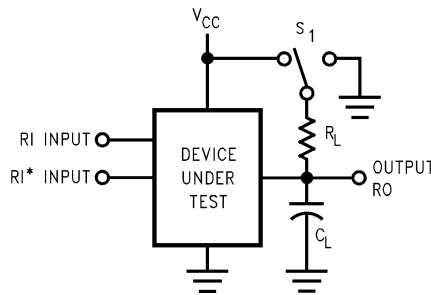

Figure 3. Propagation Delays



C_L includes load and test jig capacitance.
 $S1 = V_{CC}$ for t_{PZL} , and t_{PLZ} measurements.
 $S1 = GND$ for t_{PZH} , and t_{PHZ} measurements.
 $S1 = Open$ for t_{PLH} , t_{PHL} , and t_{SK} .

Figure 4. Test Circuit for Switching Characteristics

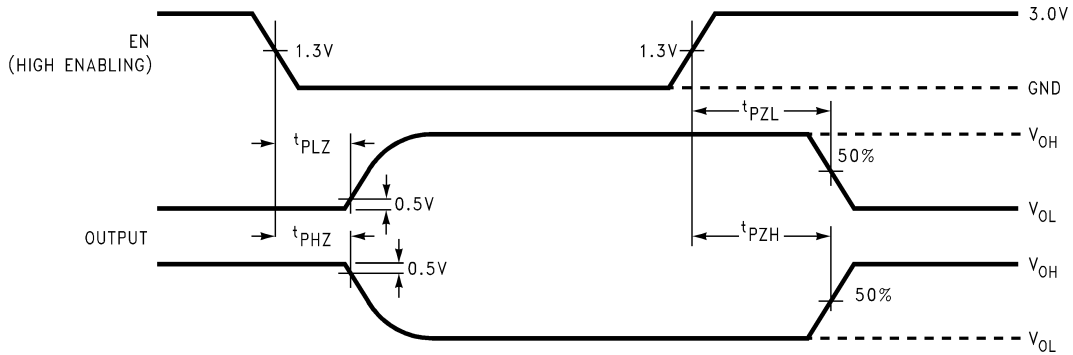
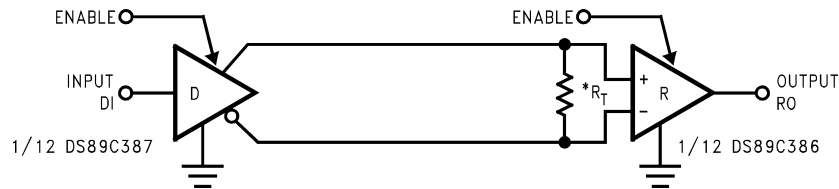

Figure 5. TRI-STATE Output Enable and Disable Waveforms

APPLICATION INFORMATION



* R_T is optional although highly recommended to reduce reflections.

Figure 6. Two-Wire Balanced System, RS-422

SKEW

Skew may be thought of in a lot of different ways, the next few paragraphs should clarify what is represented by t_{SK} in this datasheet and how it is determined. Skew, as used in this databook, is the absolute value of a mathematical difference between two propagation delays. This is commonly accepted throughout the semiconductor industry. However, there is no standardized method of measuring propagation delay, from which skew is calculated, of differential line receivers. Elucidating, the voltage level, at which propagation delays are measured, on both input and output waveforms are not always constant. Therefore, skew calculated in this datasheet, may not be calculated the same as skew defined in another. This is important to remember whenever making a skew comparison.

Skew may be calculated for the DS89C386, from many different propagation delay measurements. They may be classified into two categories, single-ended and differential. Single-ended skew is calculated from t_{PHL} and t_{PLH} propagation delay measurements (see Figure 8 and Figure 10). Differential skew is calculated from t_{PHLD} and t_{PLHD} differential propagation delay measurements (see Figure 11 and Figure 12).

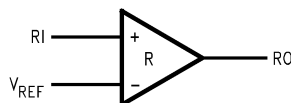

Figure 7. (Circuit 1) – Circuits for Measuring Single-Ended Propagation Delays (See Figure 10)

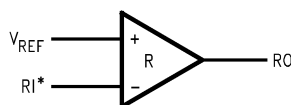

Figure 8. (Circuit 2) – Circuits for Measuring Single-Ended Propagation Delays (See Figure 10)

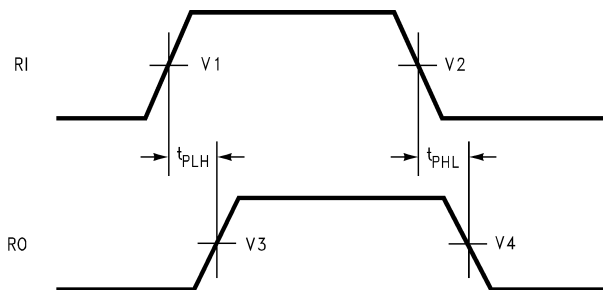

Figure 9. Waveforms for Circuit 1 – Propagation Delay Waveforms for Circuit 1 and Circuit 2 (See Figure 8)

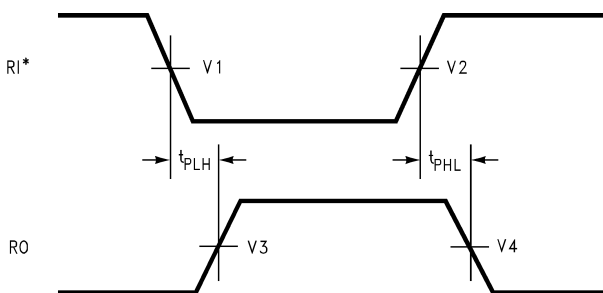

Figure 10. Waveforms for Circuit 2 – Propagation Delay Waveforms for Circuit 1 and Circuit 2 (See Figure 8)

In [Figure 10](#), V_X , where X is a number, is the waveform voltage level at which the propagation delay measurement either starts or stops. Furthermore, V_1 and V_2 are normally identical. The same is true for V_3 and V_4 . However, as mentioned before, these levels are not standardized and may vary, even with similar devices from other companies. Also note, V_{REF} in [Figure 3](#) should equal V_1 and V_2 in [Figure 10](#).

The single-ended skew provides information about the pulse width distortion of the output waveform. The lower the skew, the less the output waveform will be distorted. For best case, skew would be zero, and the output duty cycle would be 50%, assuming the input has a 50% duty cycle.

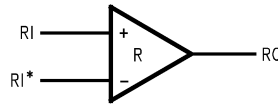

Figure 11. (Circuit 3) – Circuit for Measuring Differential Propagation Delays
(See [Figure 12](#))

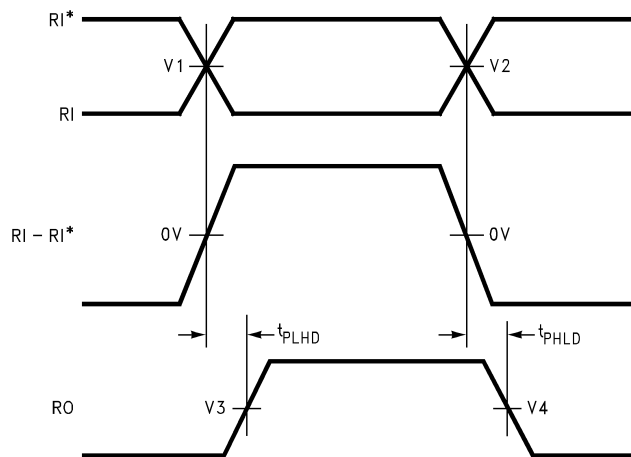

Figure 12. Waveforms for Circuit 3 – Propagation Delay Waveforms
for Circuit 3
(see [Figure 11](#))

For differential propagation delays, V_1 may not equal V_2 . Furthermore, the crossing point of RI and RI^* corresponds to zero volts on the differential waveform. (See middle waveform in [Figure 12](#).) This is true whether V_1 equals V_2 or not. However, if V_1 and V_2 are specified voltages, then V_1 and V_2 are less likely to be equal to the crossing point voltage. Thus, the differential propagation delays will not be measured from zero volts on the differential waveform.

The differential skew also provides information about the pulse width distortion of the output waveform relative to the differential input waveform. The higher the skew, the greater the distortion of the output waveform. Assuming the differential input has a 50% duty cycle, the output will have a 50% duty cycle if skew equals zero and less than a 50% duty cycle if skew is greater than zero.

Only t_{SK} is specified in this datasheet for the DS89C386. t_{SK} is measured single-endedly but corresponds to differential skew. Because, for single-ended skew, when V_{REF} equals V_1 and V_2 , t_{PHL} equals t_{PHLD} when t_{PHLD} is measured from the crossing point.

More information can be calculated from the propagation delays. The channel to channel and device to device skew may be calculated in addition to the types of skew mentioned previously. These parameters provide timing performance information beneficial when designing. The channel to channel skew is calculated from the variation in propagation delay from receiver to receiver within one package. The device to device skew is calculated from the variation in propagation delay from one DS89C386 to another DS89C386.

For the DS89C386, the maximum channel to channel skew is 20 ns ($t_p \text{ max} - t_p \text{ min}$) where t_p is the low to high or high to low propagation delay. The minimum channel to channel skew is 0 ns since it is possible for all 12 receivers to have identical propagation delays. Note, this is best and worst case calculations used whenever t_{SK} (channel) is not independently characterized and specified in the datasheet. The device to device skew may be calculated in the same way and the results are identical. Therefore, the device to device skew is 20 ns and 0 ns maximum and minimum respectively.

Table 1. DS89C386 Skew Table

Parameter	Min	Typ	Max	Units
t_{SK} (diff.)	0	2	4	ns
t_{SK} (channel)	0		20	ns
t_{SK} (device)	0		20	ns

Note t_{SK} (diff.) in Table 1 is the same as t_{SK} in the datasheet. Also, t_{SK} (channel) and t_{SK} (device) are calculations, but are ensured by the propagation delay tests. Both t_{SK} (channel) and t_{SK} (device) would normally be tighter whenever specified from characterization data.

The information in this section of the datasheet is to help clarify how skew is defined in this datasheet. This should help when designing the DS89C386 into most applications.

Typical Performance Characteristics

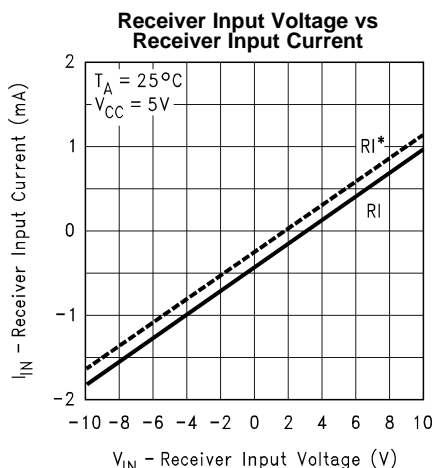

The DS89C386 is V.11 compatible. I_{IN} (RI input) is not ≥ 0 when $V_{IN} = 3V$ due to internal failsafe bias resistors (see Figure 10). See ITU V.11 for complete conditions.

Failsafe (open inputs) is maintained over entire common mode range and operating range $\pm 10V$.
Figure 13.

DS89C386 Equivalent Input/Output Circuits

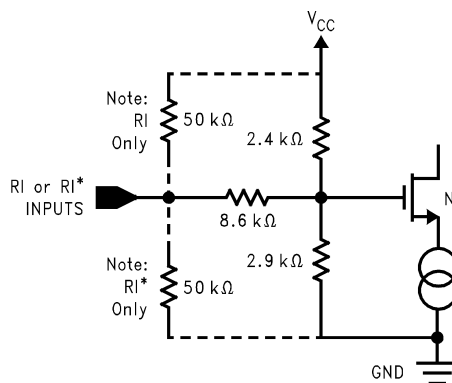

Figure 14. Receiver Input Equivalent Circuit

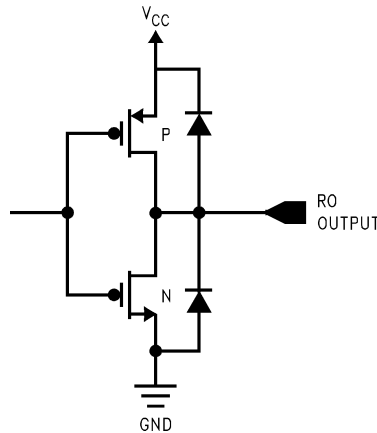

Figure 15. Receiver Output Equivalent Circuit

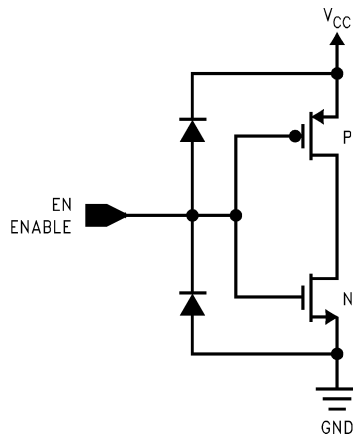

Figure 16. Receiver Enable Equivalent Circuit

Table 2. Pin Descriptions

Pin No.	Pin Name	Pin Description
2, 4, 9, 11, 17, 19, 26, 28, 33, 35, 41, 43	RO	TTL/CMOS Compatible Receiver Output Pin
5, 8, 12, 16, 20, 23, 29, 32, 36, 40, 44, 47	RI	Non-Inverting Signal Receiver Input Pin
6, 7, 13, 15, 21, 22, 30, 31, 37, 39, 45, 46	RI*	Inverting Signal Receiver Input Pin
3, 10, 18, 27, 34, 42	EN	Active High Dual Receiver Enabling Pin
38	V _{CC}	Positive Power Supply Pin +5 ±10%
14, 24	GND	Device Ground Pin
1, 25, 48	NC	Unused Pin (NOT CONNECTED)

REVISION HISTORY

Changes from Revision B (April 2013) to Revision C	Page
• Changed layout of National Data Sheet to TI format	8

PACKAGING INFORMATION

Orderable Device	Status (1)	Package Type	Package Drawing	Pins	Package Qty	Eco Plan (2)	Lead/Ball Finish (6)	MSL Peak Temp (3)	Op Temp (°C)	Device Marking (4/5)	Samples
DS89C386TMEA	NRND	SSOP	DL	48	29	TBD	Call TI	Call TI	-40 to 85	DS89C386T MEA	
DS89C386TMEA/NOPB	ACTIVE	SSOP	DL	48	29	Pb-Free (RoHS)	CU SN	Level-2A-260C-4 WEEK	-40 to 85	DS89C386T MEA	Samples

(1) The marketing status values are defined as follows:

ACTIVE: Product device recommended for new designs.

LIFEBUY: TI has announced that the device will be discontinued, and a lifetime-buy period is in effect.

NRND: Not recommended for new designs. Device is in production to support existing customers, but TI does not recommend using this part in a new design.

PREVIEW: Device has been announced but is not in production. Samples may or may not be available.

OBSELETE: TI has discontinued the production of the device.

(2) Eco Plan - The planned eco-friendly classification: Pb-Free (RoHS), Pb-Free (RoHS Exempt), or Green (RoHS & no Sb/Br) - please check <http://www.ti.com/productcontent> for the latest availability information and additional product content details.

TBD: The Pb-Free/Green conversion plan has not been defined.

Pb-Free (RoHS): TI's terms "Lead-Free" or "Pb-Free" mean semiconductor products that are compatible with the current RoHS requirements for all 6 substances, including the requirement that lead not exceed 0.1% by weight in homogeneous materials. Where designed to be soldered at high temperatures, TI Pb-Free products are suitable for use in specified lead-free processes.

Pb-Free (RoHS Exempt): This component has a RoHS exemption for either 1) lead-based flip-chip solder bumps used between the die and package, or 2) lead-based die adhesive used between the die and leadframe. The component is otherwise considered Pb-Free (RoHS compatible) as defined above.

Green (RoHS & no Sb/Br): TI defines "Green" to mean Pb-Free (RoHS compatible), and free of Bromine (Br) and Antimony (Sb) based flame retardants (Br or Sb do not exceed 0.1% by weight in homogeneous material)

(3) MSL, Peak Temp. - The Moisture Sensitivity Level rating according to the JEDEC industry standard classifications, and peak solder temperature.

(4) There may be additional marking, which relates to the logo, the lot trace code information, or the environmental category on the device.

(5) Multiple Device Markings will be inside parentheses. Only one Device Marking contained in parentheses and separated by a "~" will appear on a device. If a line is indented then it is a continuation of the previous line and the two combined represent the entire Device Marking for that device.

(6) Lead/Ball Finish - Orderable Devices may have multiple material finish options. Finish options are separated by a vertical ruled line. Lead/Ball Finish values may wrap to two lines if the finish value exceeds the maximum column width.

Important Information and Disclaimer: The information provided on this page represents TI's knowledge and belief as of the date that it is provided. TI bases its knowledge and belief on information provided by third parties, and makes no representation or warranty as to the accuracy of such information. Efforts are underway to better integrate information from third parties. TI has taken and continues to take reasonable steps to provide representative and accurate information but may not have conducted destructive testing or chemical analysis on incoming materials and chemicals. TI and TI suppliers consider certain information to be proprietary, and thus CAS numbers and other limited information may not be available for release.

In no event shall TI's liability arising out of such information exceed the total purchase price of the TI part(s) at issue in this document sold by TI to Customer on an annual basis.

MECHANICAL DATA

DL (R-PDSO-G48)

PLASTIC SMALL-OUTLINE PACKAGE



- NOTES:
- All linear dimensions are in inches (millimeters).
 - This drawing is subject to change without notice.
 - Body dimensions do not include mold flash or protrusion not to exceed 0.006 (0,15).
 - Falls within JEDEC MO-118

PowerPAD is a trademark of Texas Instruments.

IMPORTANT NOTICE

Texas Instruments Incorporated and its subsidiaries (TI) reserve the right to make corrections, enhancements, improvements and other changes to its semiconductor products and services per JESD46, latest issue, and to discontinue any product or service per JESD48, latest issue. Buyers should obtain the latest relevant information before placing orders and should verify that such information is current and complete. All semiconductor products (also referred to herein as "components") are sold subject to TI's terms and conditions of sale supplied at the time of order acknowledgment.

TI warrants performance of its components to the specifications applicable at the time of sale, in accordance with the warranty in TI's terms and conditions of sale of semiconductor products. Testing and other quality control techniques are used to the extent TI deems necessary to support this warranty. Except where mandated by applicable law, testing of all parameters of each component is not necessarily performed.

TI assumes no liability for applications assistance or the design of Buyers' products. Buyers are responsible for their products and applications using TI components. To minimize the risks associated with Buyers' products and applications, Buyers should provide adequate design and operating safeguards.

TI does not warrant or represent that any license, either express or implied, is granted under any patent right, copyright, mask work right, or other intellectual property right relating to any combination, machine, or process in which TI components or services are used. Information published by TI regarding third-party products or services does not constitute a license to use such products or services or a warranty or endorsement thereof. Use of such information may require a license from a third party under the patents or other intellectual property of the third party, or a license from TI under the patents or other intellectual property of TI.

Reproduction of significant portions of TI information in TI data books or data sheets is permissible only if reproduction is without alteration and is accompanied by all associated warranties, conditions, limitations, and notices. TI is not responsible or liable for such altered documentation. Information of third parties may be subject to additional restrictions.

Resale of TI components or services with statements different from or beyond the parameters stated by TI for that component or service voids all express and any implied warranties for the associated TI component or service and is an unfair and deceptive business practice. TI is not responsible or liable for any such statements.

Buyer acknowledges and agrees that it is solely responsible for compliance with all legal, regulatory and safety-related requirements concerning its products, and any use of TI components in its applications, notwithstanding any applications-related information or support that may be provided by TI. Buyer represents and agrees that it has all the necessary expertise to create and implement safeguards which anticipate dangerous consequences of failures, monitor failures and their consequences, lessen the likelihood of failures that might cause harm and take appropriate remedial actions. Buyer will fully indemnify TI and its representatives against any damages arising out of the use of any TI components in safety-critical applications.

In some cases, TI components may be promoted specifically to facilitate safety-related applications. With such components, TI's goal is to help enable customers to design and create their own end-product solutions that meet applicable functional safety standards and requirements. Nonetheless, such components are subject to these terms.

No TI components are authorized for use in FDA Class III (or similar life-critical medical equipment) unless authorized officers of the parties have executed a special agreement specifically governing such use.

Only those TI components which TI has specifically designated as military grade or "enhanced plastic" are designed and intended for use in military/aerospace applications or environments. Buyer acknowledges and agrees that any military or aerospace use of TI components which have **not** been so designated is solely at the Buyer's risk, and that Buyer is solely responsible for compliance with all legal and regulatory requirements in connection with such use.

TI has specifically designated certain components as meeting ISO/TS16949 requirements, mainly for automotive use. In any case of use of non-designated products, TI will not be responsible for any failure to meet ISO/TS16949.

Products

Audio	www.ti.com/audio
Amplifiers	amplifier.ti.com
Data Converters	dataconverter.ti.com
DLP® Products	www.dlp.com
DSP	dsp.ti.com
Clocks and Timers	www.ti.com/clocks
Interface	interface.ti.com
Logic	logic.ti.com
Power Mgmt	power.ti.com
Microcontrollers	microcontroller.ti.com
RFID	www.ti-rfid.com
OMAP Applications Processors	www.ti.com/omap
Wireless Connectivity	www.ti.com/wirelessconnectivity

Applications

Automotive and Transportation	www.ti.com/automotive
Communications and Telecom	www.ti.com/communications
Computers and Peripherals	www.ti.com/computers
Consumer Electronics	www.ti.com/consumer-apps
Energy and Lighting	www.ti.com/energy
Industrial	www.ti.com/industrial
Medical	www.ti.com/medical
Security	www.ti.com/security
Space, Avionics and Defense	www.ti.com/space-avionics-defense
Video and Imaging	www.ti.com/video

TI E2E Community

e2e.ti.com