

### Process Controller Conforming to DeviceNet

- Conforms to the DeviceNet and connects to a programmable logic controller without any programming
- High performance range of 0.1% FS (Pt input: -100.0°C to 100.0°C)
- 24 V type also available



### Ordering Information

#### ■ PROCESS CONTROLLER

Item	Communications	Size	Part number
Controller	DeviceNet	48 x 96 mm	E5EK-AA2-DRT

- Note: 1. The heater burnout alarm function can be used only when an ON/OFF output board is used for the control outputs (heat).  
 2. Be sure to specify the current transformer and output board when ordering.

#### ■ OUTPUT BOARD (ORDER SEPARATELY)

Item	Specification	Part number
Output board	Relay	E53-R
	SSR	E53-S
	Pulse (NPN) 12 VDC	E53-Q
	Pulse (NPN) 24 VDC	E53-Q3
	Pulse (PNP) 24 VDC	E53-Q4
	Linear (4 to 20 mA)	E53-C3
	Linear (0 to 20 mA)	E53-C3D
	Linear (0 to 10 V)	E53-V34
	Linear (0 to 5 V)	E53-V35

- Note: The Process Controller uses a dedicated, high-resolution output board. The E53-C current output board for the E5□X cannot be used with the Process Controller.

## ■ ACCESSORIES (ORDER SEPARATELY)

### Current Transformer

Item	Hole diameter	Part number
Current transformer	5.8 mm	E54-CT1
	12.0 mm	E54-CT3

Note: No CT is required unless the heater burnout alarm function is used.

### Terminal Cover

Item	Connectable models	Part number
Terminal cover	E5EK	E53-COV08

### Cables/Connections

Item	Description	Part number
One-branch T-branch tap	With three connectors	DCN1-1C
Two-branch T-branch tap	With five connectors	DCN1-3C
Terminal block terminating resistor	Resistance: 121 Ω	DRS1-T

Note: Refer to *CompoBus/D Operation Manual (W267)* and *CompoBus/D Catalog (Q102)* for details such as ratings and characteristics.

## ■ RANGES

### Platinum Resistance Thermometer

Input (switch selectable)		JPt100	Pt100	
Range	°C	-199.9 to 650.0	-199.9 to 650.0	-100.0 to 100.0
	°F	-199.9 to 999.9	-199.9 to 999.9	-150.0 to 250.0
Setting		0	1	22

### Thermocouple

Input (switch selectable) (See Note.)	K	J		T	E	L		U	N	R	S	B	W	PLII	
		°C	°F	°C	°F	°C	°F	°C	°F	°C	°F	°C	°F	°C	°F
Range	-200 to 1,300	0.0 to 500.0	-100 to 850	0.0 to 400.0	-199.9 to 400.0	0 to 600	-100 to 850	0.0 to 400.0	-199.9 to 400.0	-200 to 1,300	0 to 1,700	0 to 1,700	100 to 1,800	0 to 2,300	0 to 1,300
	-300 to 2,300	0.0 to 900.0	-100 to 1,500	0.0 to 750.0	-199.9 to 700.0	0 to 1,100	-100 to 1,500	0.0 to 750.0	-199.9 to 700.0	-300 to 2,300	0 to 3,000	0 to 3,000	300 to 3,200	0 to 4,100	0 to 2,300
Setting	2	3	4	5	6	7	8	9	10	11	12	13	14	15	16

Note: Setting number is factory-set to 2 (K).

Thermocouple W is W/Re5-26 (tungsten rhenium 5, tungsten rhenium 26).

## ■ CURRENT/VOLTAGE

Input (switch selectable)	Current input		Voltage input		
	4 to 20 mA	0 to 20 mA	1 to 5 V	0 to 5 V	0 to 10 V
Range	One of following ranges depending on results of scaling -1999 to 9999 -199.9 to 999.9 -19.99 to 99.99 -1.999 to 9.999				
Setting	17	18	19	20	21

# Specifications

## ■ RATINGS

Supply voltage		100 to 240 VAC, 50/60 Hz, 24 VAC/DC
Operating voltage range		85% to 110% of rated supply voltage
Power consumption		15 VA (100 to 240 VAC), 12 VA (24 VAC), 8 W (24 VDC)
Input		Thermocouple: K, J, T, E, L, U, N, R, S, B, W, PLII Platinum resistance thermometer: JPt100, Pt100 Current input: 4 to 20 mA, 0 to 20 mA (input impedance: 150 $\Omega$ ) Voltage input: 1 to 5 V, 0 to 5 V, 0 to 10 V (input impedance: 1 M $\Omega$ )
Input impedance	Current input	150 $\Omega$
	Voltage input	1 M $\Omega$ min.
Auxiliary output		SPST-NO, 3 A at 250 VAC (resistive load)
Control method		ON/OFF or advanced PID control (with auto-tuning)
Setting method		Digital setting using front panel keys
Indication method		7-segment digital display and LEDs (character height: PV: 14 mm, SV: 9.5 mm)
Control output		According to output board (see <i>Output Board Ratings and Characteristics</i> ) Attach an output board that is sold separately.
Remote SP input		Current input: 4 to 20 mA (input impedance: 150 $\Omega$ )
Current transformer input		Connect an exclusive current transformer (E54-CT1 or E54-CT3)
Additional functions	Standard	Manual output, heating/cooling control, SP limiter, loop burnout alarm, SP ramp, MV limiter, MV change rate limiter, input digital filter, input shift, run/stop, protect functions
	Option	Run/Stop selection, etc.

- Note: 1. To conform to EN50081-2 (FCC Class A) for ratings of noise terminal voltages, attach a noise filter (TDK ZCB2206-11 or equivalent) to the AC power supply line.  
2. Fuzzy self-tuning is not provided with the E5EK-DRT.

## ■ CHARACTERISTICS

Indication accuracy		Thermocouple (See Note 1.): ( $\pm 0.3\%$ of indication value or $\pm 1^\circ\text{C}$ , whichever greater) $\pm 1$ digit max. Platinum resistance thermometer (See Note 2.): ( $\pm 0.2\%$ of indication value or $\pm 0.8^\circ\text{C}$ , whichever greater) $\pm 1$ digit max. Analog input: $\pm 0.2\%$ FS $\pm 1$ digit max.
Hysteresis		0.01% to 99.99% FS (in units of 0.01% FS)
Proportional band (P)		0.1% to 999.9% FS (in units of 0.1% FS)
Integral (reset) time (I)		0 to 3,999 s (in units of 1 s)
Derivative (rate) time (D)		0 to 3,999 s (in units of 1 s)
Control period		1 to 99 s (in units of 1 s)
Manual reset value		0.0% to 100.0% (in units of 0.1%)
Alarm setting range		-1,999 to 9,999 or -199.9 or 999.9 (decimal point position dependent on input type)
Sampling period (See Note 3.)	Temperature input	250 ms
	Analog input	100 ms
Insulation resistance		20 M $\Omega$ min. (at 500 VDC)
Dielectric strength		2,000 VAC, 50/60 Hz for 1 min between terminals of different polarities

(This table continues on the next page.)

- Note: 1. The indication accuracy of the K, T, and N thermocouples at a temperature of  $-100^\circ\text{C}$  or less is  $\pm 2^\circ\text{C} \pm 1$  digit maximum. The indication accuracy of the B thermocouple at a temperature of  $400^\circ\text{C}$  or less is unrestricted. The indication accuracy of the R and S thermocouples at a temperature of  $200^\circ\text{C}$  or less is  $\pm 3^\circ\text{C} \pm 1$  digit maximum. The indication accuracy of the W thermocouple at any temperature is ( $\pm 0.3\%$  of the indicated value or  $\pm 3^\circ\text{C}$ , whichever is greater)  $\pm 1$  digit maximum. The indication accuracy of the PLII thermocouple at any temperature is ( $\pm 0.3\%$  or  $\pm 2^\circ\text{C}$ , whichever is greater)  $\pm 1$  digit maximum.  
2. The indication accuracy of the Pt at  $-100.0^\circ\text{C}$  to  $100.0^\circ\text{C}$  is  $\pm 0.1\%$  FS  $\pm 1$  digit maximum.  
3. The sampling period of the standard model with CT and remote SP inputs is 250 ms.

Characteristics Table - continued from previous page

Vibration resistance	Malfunction: 10 to 55 Hz, 10 m/s <sup>2</sup> (approx. 1G) for 10 min each in X, Y, and Z directions Destruction: 10 to 55 Hz, 20 m/s <sup>2</sup> (approx. 2G) for 2 hrs each in X, Y, and Z directions	
Shock resistance	Malfunction: 200 m/s <sup>2</sup> min. (approx. 20G), 3 times each in 6 directions (100 m/s <sup>2</sup> (approx. 10G) applied to the relay) Destruction: 300 m/s <sup>2</sup> min. (approx. 30G), 3 times each in 6 directions	
Ambient temperature	Operating	-10 to 55°C (14 to 131°F) with no icing/3-year warranty period: -10 to 50°C (14 to 122°F)
	Storage	-25 to 65°C (-13 to 149°F) with no icing
Ambient humidity	Operating	35% to 85%
Enclosure ratings	Front panel	NEMA4 for indoor use (equivalent to IP66)
	Rear case	IEC standard IP20
	Terminals	IEC standard IP00
Memory protection	Non-volatile memory (number of writings: 100,000 operations)	
Weight	Approx. 320 g	
	Mounting bracket: approx. 65 g	
EMC	Emission Enclosure:	EN55011 Group 1 class A
	Emission AC Mains:	EN55011 Group 1 class A
	Immunity ESD:	EN61000-4-2:4 kV contact discharge (level 2) 8 kV air discharge (level 3)
	Immunity RF-interference:	ENV50140: 10 V/m
		(amplitude modulated, 80 MHz to 1 GHz) (level 3) 10 V/m (pulse modulated, 900 MHz)
	Immunity Conducted Disturbance:	ENV50141: 10 V (0.15 to 80 MHz) (level 3)
	Immunity Burst:	EN61000-4-4: 2 kV power-line (level 3)
		2 kV I/O signal-line (level 4)
Approved standards	UL1092, CSA22.2 No. 14, CSA22.2 No. 1010-1 Conforms to EN50081-2, EN50082-2, EN61010-1 (IEC61010-1) Conforms to VDE0106/part 100 (Finger Protection), when the separately-ordered terminal cover is mounted.	

## ■ COMMUNICATION CHARACTERISTICS

Conforms to DeviceNet communications protocol.

For details, refer to the *CompoBus/D Operation Manual (W267)* and *E5EK CompoBus/D-type Controller Operation Manual (Z119)*.

Connection forms	Combination of multi-drop and T-branch connections (See Note 1.)	
Communications baud rate	500 kbps, 250 kbps, or 125 kbps (set using the front panel keys)	
Communications media	Special 5-wire cables (2 signal lines, 2 power lines, 1 shield line)	
Communications distance	500 kbps	Network length (See Note 2.): 100 m max. (See Note 3.) Drop line length: 6 m max. Total drop line length: 39 m max.
	250 kbps	Network length (See Note 2.): 250 m max. (See Note 3.) Drop line length: 6 m max. Total drop line length: 78 m max.
	125 kbps	Network length (See Note 2.): 500 m max. (See Note 3.) Drop line length: 6 m max. Total drop line length: 156 m max.
Max. number of nodes	64 nodes (including master)	
Max. number of slaves	63 slaves	
Error control checks	CRC error check, duplicate node address check	

Note: 1. External terminating resistor is required.

2. Indicates the maximum distance between nodes.

3. The distance is less than 100 m when thin cables are used for the trunk lines.

## ■ OUTPUT BOARD RATINGS AND CHARACTERISTICS

Relay output	5 A at 250 VAC (resistive load)
SSR output	1 A at 75 to 250 VAC (resistive load)
Voltage output	NPN: 40 mA at 12 VDC (with short-circuit protection) NPN: 20 mA at 24 VDC (with short-circuit protection) PNP: 20 mA at 24 VDC (with short-circuit protection)
Linear current output	4 to 20 mA, permissible load impedance: 600 $\Omega$ max., resolution: approx. 2,600 0 to 20 mA, permissible load impedance: 600 $\Omega$ max., resolution: approx. 2,600
Linear voltage output	0 to 10 VDC, permissible load impedance: 1 k $\Omega$ max., resolution: approx. 2,600 0 to 5 VDC, permissible load impedance: 1 k $\Omega$ max., resolution: approx. 2,600

## ■ CURRENT TRANSFORMER RATINGS

Dielectric strength	1,000 VAC (for 1 min)
Vibration resistance	50 Hz, 98 m/s <sup>2</sup> (10G)
Weight	E54-CT1: approx. 11.5 g; E54-CT3: approx. 50 g
Accessories (E54-CT3 only)	Armature: 2; Plug: 2

## ■ HEATER BURNOUT ALARM

Max. heater current	Single-phase 50 A AC (See Note 1.)
Heater current value display accuracy	$\pm 5\%$ FS $\pm 1$ digit max.
Heater burnout alarm setting range	0.1 to 49.9 A (in units of 0.1 A) (See Note 2.)
Min. detection ON time	190 ms (See Note 3.)

- Note: 1. Use the K2CU-F□□A-□GS (with gate input terminals) for the detection of three-phase heater burnout.  
 2. The heater burnout alarm is always OFF if the alarm is set to 0.0 A and always ON if the alarm is set to 50.0 A.  
 3. No heater burnout detection or heater current value measurement is possible if the control output (heat) is ON for less than 190 ms.

This product has been tested by ODVA's authorized Independent Test Lab and found to comply with ODVA Conformance Test Software Version 2.0-1.00.

# Dimensions

Unit: mm (inch)

## E5EK-DRT

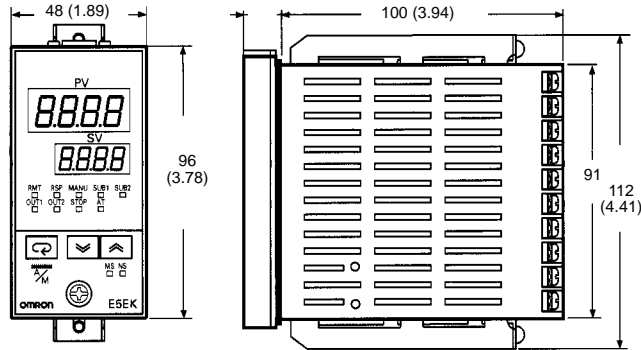
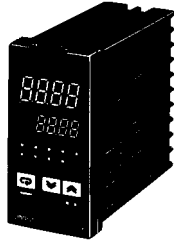

Note: Rear case width is 44 mm.

### Panel Cutouts

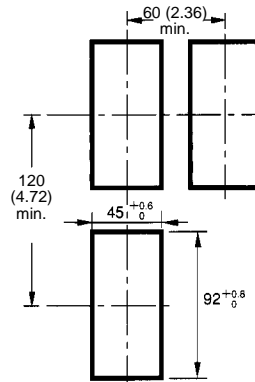

- Note: 1. Recommended panel thickness is 1 to 8 mm.
- 2. Maintain the specified vertical and horizontal mounting space between each Unit. Units must not be closely mounted (vertically or horizontally).

# Installation

## EXTERNAL CONNECTION

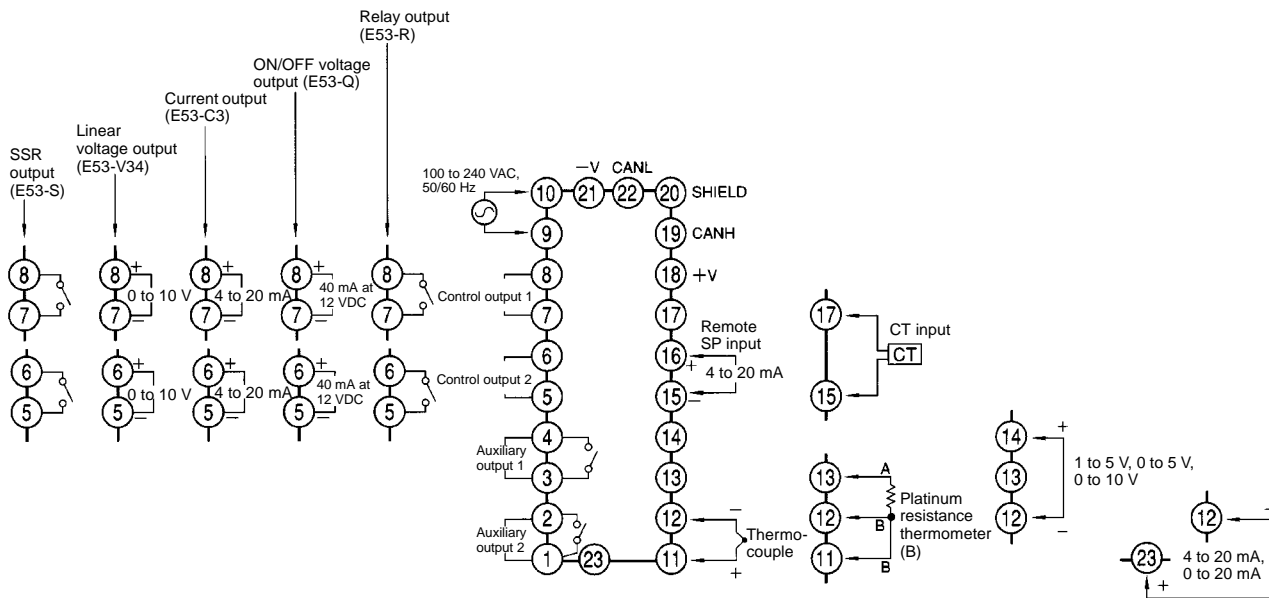

## Precautions

---

For application precautions, refer to the *CompoBus/D Operation Manual (W267)* and *E5EK-DRT User Manual*, Cat. No. H099-E3-1.

---

**OMRON**<sup>®</sup>  
**OMRON ELECTRONICS, INC.**  
One East Commerce Drive  
Schaumburg, IL 60173  
**1-800-55-OMRON**

**OMRON CANADA, INC.**  
885 Milner Avenue  
Scarborough, Ontario M1B 5V8  
**416-286-6465**