



DP86

SPECIFICATIONS

- 316L SS
- Wet/Wet Differential
- Low Pressure

FEATURES

- O-Ring Mount
- Up to -40°C to +125°C Operating Range
- Up to $\pm 0.1\%$ Pressure Non-Linearity
- Solid State Reliability
- Low Pressure

APPLICATIONS

- Level Controls
- Tank Level Measurement
- OEM Equipment
- Corrosive Fluids and Gas Measurement Systems
- Flow Measurements

The DP86 differential pressure sensor is a double-sided, media compatible, piezoresistive silicon pressure sensor packaged in a 316L stainless steel housing designed for O-ring mounting applications. The sensing package utilizes silicone oil to transfer pressure from the two 316L stainless steel diaphragms to a single sensing element.

The DP86 is designed for high performance, low pressure applications where differential pressure measurement is required. The stainless steel package makes it suitable for use in liquids and corrosive environments.

Please refer to the DP86 uncompensated, non-silicone oil, constant current and constant voltage (fittings and cable design) for more information on different features of the DP86.

STANDARD RANGES

Range	psid
0 to 1	•
0 to 5	•
0 to 15	•
0 to 30	•
0 to 50	•
0 to 100	•
0 to 300	•
0 to 500	•

PERFORMANCE SPECIFICATIONS

Unless otherwise specified, Supply Current: 1.5mA; Ambient Temperature: 25°C

PARAMETERS	001PSI			005PSI			≥015PSI			UNITS	NOTES
	MIN	TYP	MAX	MIN	TYP	MAX	MIN	TYP	MAX		
Sensitivity	9.0		20.0	12.5	19.5	26.5	13.2	20	26.5	mV/V@FS	
Zero Pressure Output	-4.0		8.0	-6.0		8.0	-6.0		8.0	mV/V	1
Pressure Non-Linearity	-0.30		0.30	-0.20		0.20	-0.10		0.10	%Span	2
Pressure Hysteresis	-0.10		0.10	-0.10		0.10	-0.05		0.05	%Span	
Input/Output Resistance	4.4		6.2	3.8	4.4	5.8	3.8	4.4	5.8	kΩ	
Temp. Coefficient – Span	-3150	-2450	-2150	-1650	-1250	-1000	-1450	-1250	-1000	ppm/°C	3
Temp. Coefficient – Offset		1			1			1		μV/V/°C	3
Temp. Coefficient – Resistance	2600	3200	3500	1300	1510	1750	1300	1510	1750	ppm/°C	3
Thermal Hysteresis – Span	-0.25		0.25	-0.25		0.25	-0.25		0.25	%Span	3
Thermal Hysteresis – Offset	-0.25		0.25	-0.25		0.25	-0.25		0.25	%Span	3
Line (Common Mode) Pressure			1000			1000			1000	psi	
Line Pressure Effect on Zero						0.8			0.5	%Span/1kpsi %Span/175psi	
Pressure Overload			10X			3X			3X	Rated	4
Pressure Burst			12X			4X			4X	Rated	5
Operating Temperature	-40		+85	-40		+125	-40		+125	°C	6
Storage Temperature	-40		+125	-40		+125	-40		+125	°C	6
Vibration (10~2000Hz)			20			20			20	g	
Insulation Resistance (50V _{DC})	50			50			50			MΩ	7
Output Load Resistance	5			5			5			MΩ	8
Supply Voltage		5.0	12.0		5.0	9.5		5	9.5	V	
Supply Current			2.0			1.5			1.5	mA	
Voltage Breakdown			500			500			500	V _{RMS}	9
Endurance (FS @ 25°C)						1,000,000				Cycles	

Media Compatibility –
Pressure Port

All fluids and gases compatible with 316L Stainless Steel & Nitrile

Notes

1. Measured at ambient pressure.
2. Best fit straight line
3. Over the temperature range -20°C to +85°C (0°C to 50°C for 1psi, 0°C to 70°C for 5psi) with respect to 25°C.
4. For high-end port, rated or 1000psi whichever is less; for low-end port, rated or 150psi whichever is less. The maximum pressure that can be applied without changing the transducer's performance or accuracy.
5. The maximum pressure that can be applied to a transducer without rupture of either the sensing element or transducer.
6. Temperature range for cable and connector is -20°C to +105°C.
7. Between case and sensing element.
8. Load resistance to reduce measurement errors due to output loading.
9. At dry air.
10. Direct mechanical contact with diaphragm is prohibited. Diaphragm surface must remain free of defects (scratches, punctures, fingerprints, etc.) for device to operate properly. Caution is advised when handling parts with exposed diaphragms. Use protective cap whenever devices are not in use.
11. Shipping:
The Stainless Steel diaphragm is protected by a static dissipative cap, each unit is packaged individually in a 2.5" plastic vial with antistatic foam, cable assembly included in vial.
12. Marking:
Device is identified with model number with Pressure Range, Type, Lot Number, Serial Number and Date Code.

DIMENSIONS

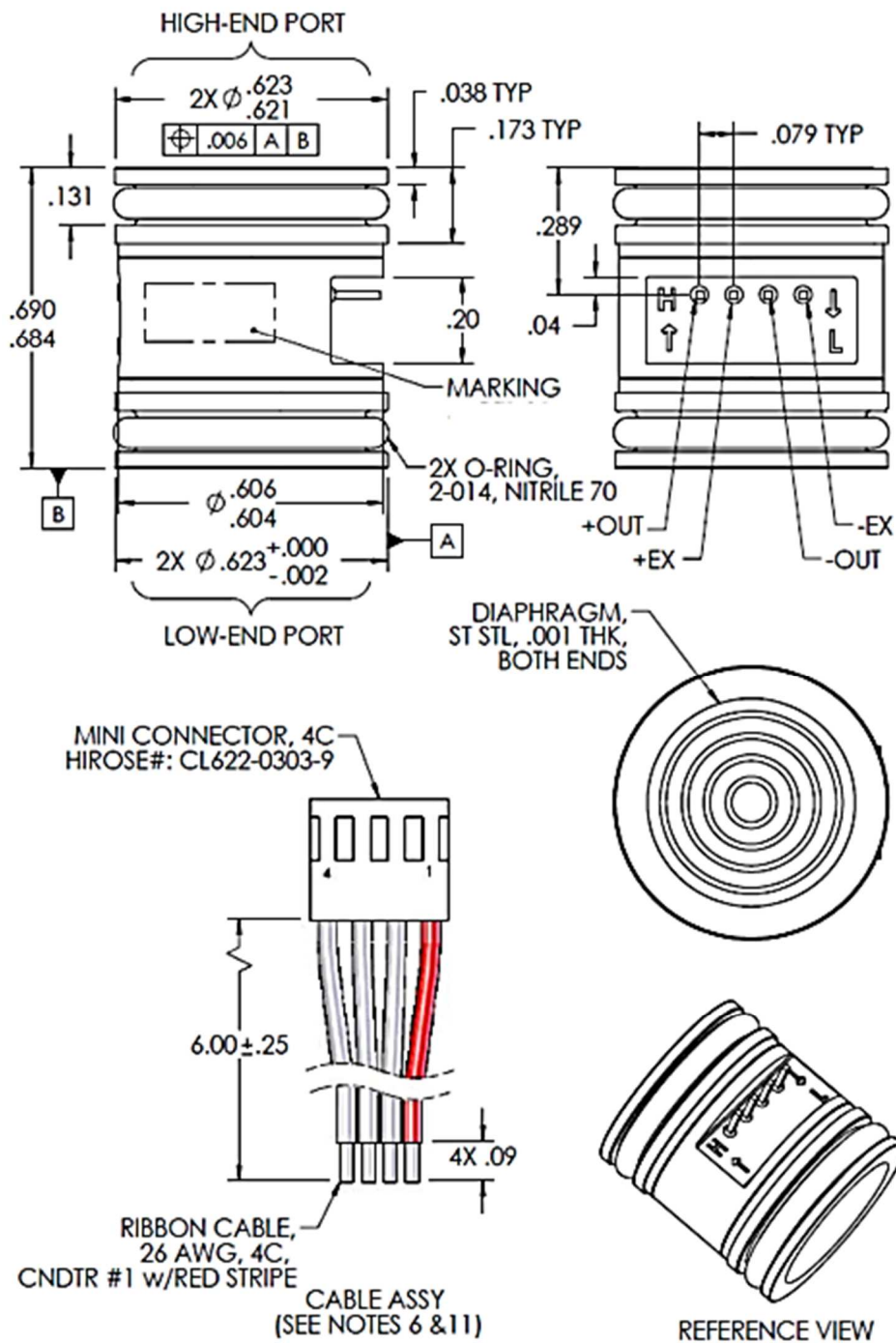

COMPENSATION SCHEMATIC

(Sensors can be compensated using the schematic to get improved performance. A calibration data sheet is included with each unit that provides measured values along with resistor values that will achieve the calculated compensated performance.)

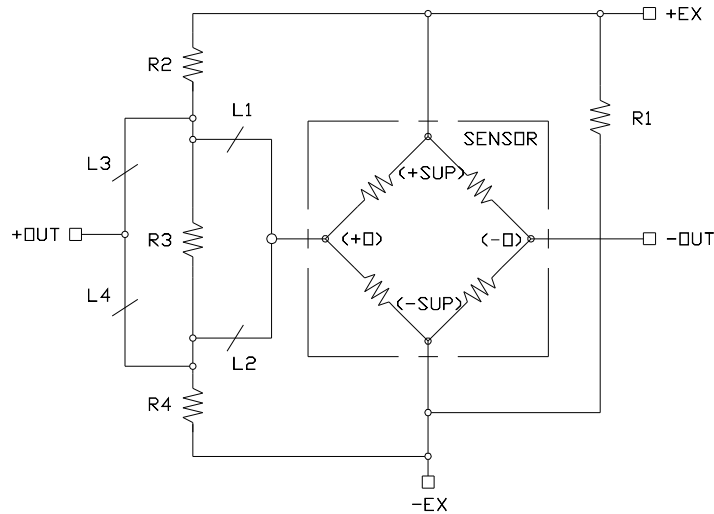

ORDERING INFORMATION

DP86 – 030 D

Pressure Range [psi]
001 (Gage Only)
005
015
030
050
100
300
500

Pressure Type	
D	Differential

NORTH AMERICA

Measurement Specialties, Inc.,
a TE Connectivity Company
Tel: +1 800-522-6752
Email: customercare.frmt@te.com

EUROPE

Measurement Specialties (Europe), Ltd.,
a TE Connectivity Company
Tel: +31 73 624 6999
Email: customercare.lcsb@te.com

ASIA

Measurement Specialties (China), Ltd.,
a TE Connectivity Company
Tel: +86 0400-820-6015
Email: customercare.shzn@te.com

TE.com/sensorsolutions

Measurement Specialties, Inc., a TE Connectivity company.

Measurement Specialties, TE Connectivity, TE Connectivity (logo) and EVERY CONNECTION COUNTS are trademarks. All other logos, products and/or company names referred to herein might be trademarks of their respective owners.

The information given herein, including drawings, illustrations and schematics which are intended for illustration purposes only, is believed to be reliable. However, TE Connectivity makes no warranties as to its accuracy or completeness and disclaims any liability in connection with its use. TE Connectivity's obligations shall only be as set forth in TE Connectivity's Standard Terms and Conditions of Sale for this product and in no case will TE Connectivity be liable for any incidental, indirect or consequential damages arising out of the sale, resale, use or misuse of the product. Users of TE Connectivity products should make their own evaluation to determine the suitability of each such product for the specific application.

© 2015 TE Connectivity Ltd. family of companies All Rights Reserved.