

# Model Numbering System

## General AC Fan

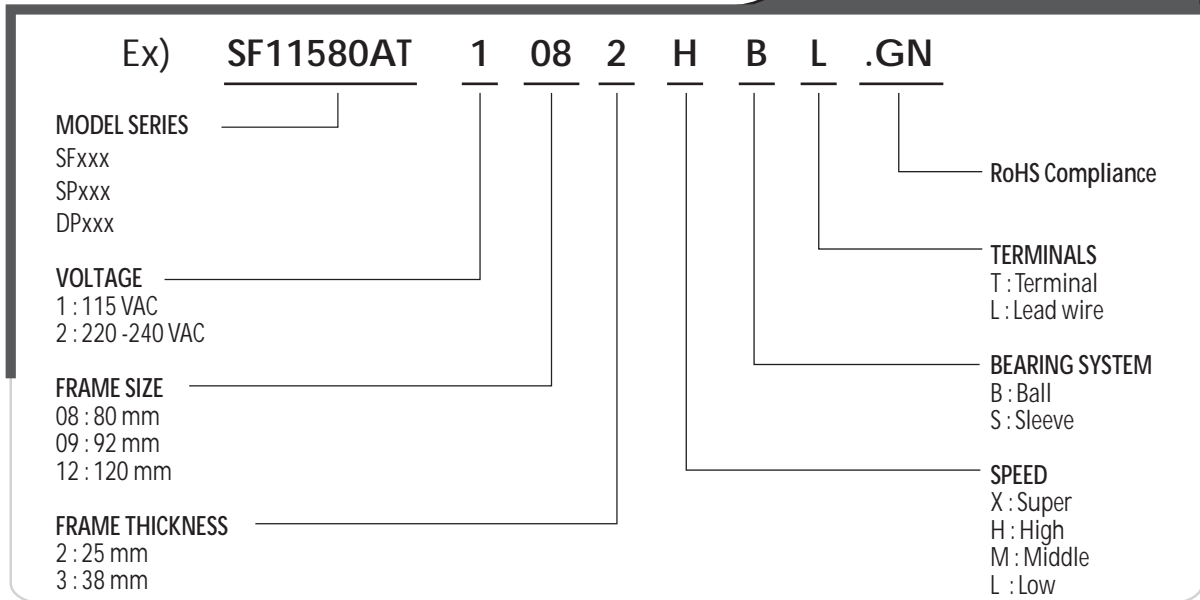

## New Type AC Fan

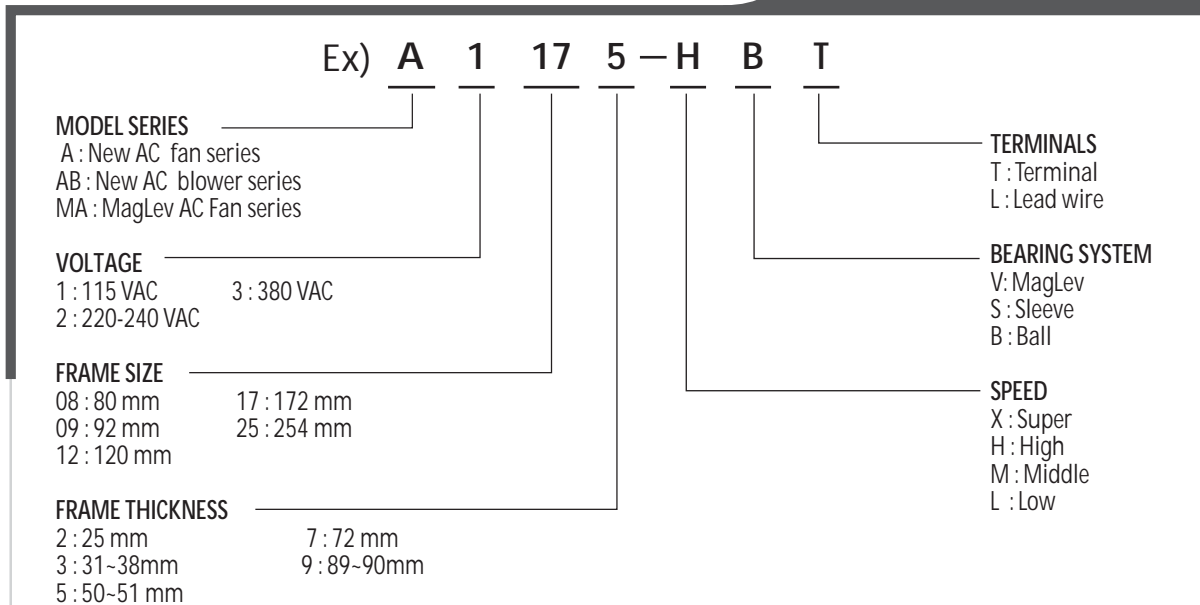

### P/N

P/N Suffixes have the following significance :

- T : Thermal Cutout
- C : Capacitor
- TC : Alveolate Motor with Thermal Cutout and Capacitor
- R : Round Frame (Blank : Standard Frame)
- GN : RoHS compliance

\* Alveolate Motor only available in P/N : TC model

# 60x60x25 mm

# SUNON

## MagLev Motor AC Fan

### 17-19 CFM



Model	P/N	Bearing ● VAPO ○ BALL ◎ Sleeve	Rating Voltage (VAC)	Freq. (Hz)	Power Current (AMP)	Power Consumption (WATTS)	Speed (RPM)	Air Flow (CFM)	Static Pressure (Inch-H <sub>2</sub> O)	Noise (dBA)	Weight (g)
MA1062-HVL	GN	●	115	50/60	0.12/0.12	3.6/3.6	3600/3700	17/19	0.15/0.17	25/27	80
MA2062-HVL	GN	●	220-240	50/60	0.10/0.10	3.8/3.8	3600/3700	17/19	0.15/0.17	25/27	80

Frame : PBT Plastic

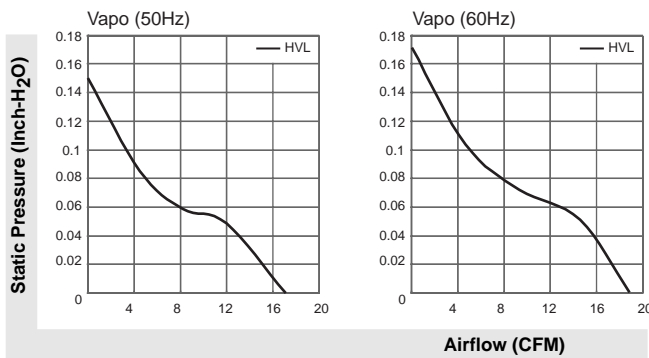

UNITS:mm

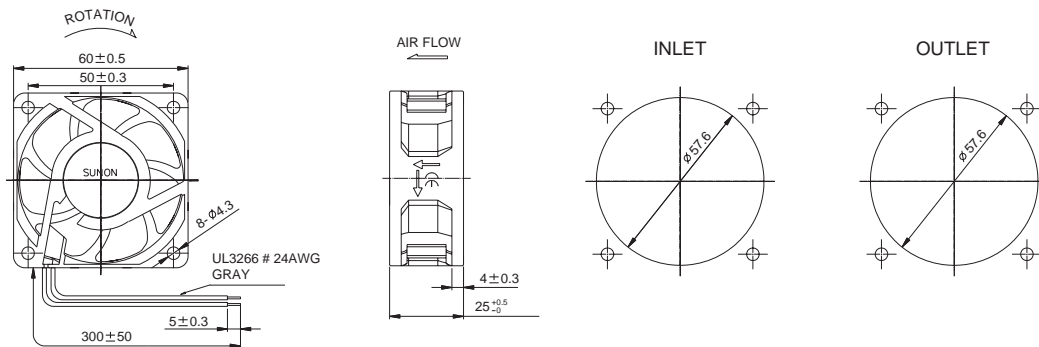

\*The rated current is TRUE RMS current measured by BASE-450(Autoranging Digital V-A-W METER).

\*All model could be customized on voltage or any other requirements to fit your need.

\*Specifications subject to change without notice. Please Visit SUNON web site at <http://www.sunon.com> for update information.

# 70x70x25 mm

# SUNON

## MagLev Motor AC Fan

### 32-33 CFM



Model	P/N	Bearing	Rating Voltage (VAC)	Freq. (Hz)	Power Current (AMP)	Power Consumption (WATTS)	Speed (RPM)	Air Flow (CFM)	Static Pressure (Inch-H <sub>2</sub> O)	Noise (dBA)	Weight (g)
MA1072-HVL	GN	● Vapo ○ BALL ◎ Sleeve	115	50/60	0.12/0.12	3.6/3.6	3400/3600	32/33	0.16/0.17	34.5/41	86
MA2072-HVL	GN	●	220-240	50/60	0.10/0.10	3.8/3.8	3400/3600	32/33	0.16/0.17	34.5/41	86

Frame : PBT Plastic

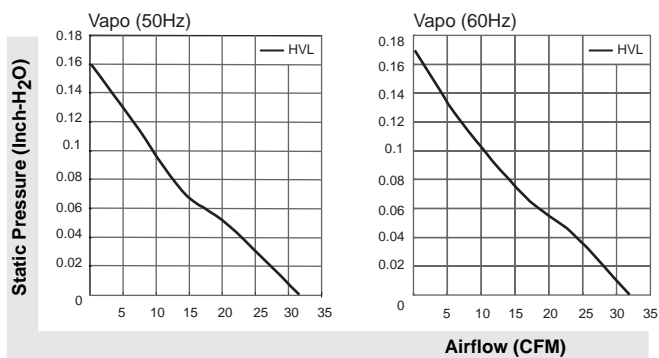

UNITS:mm

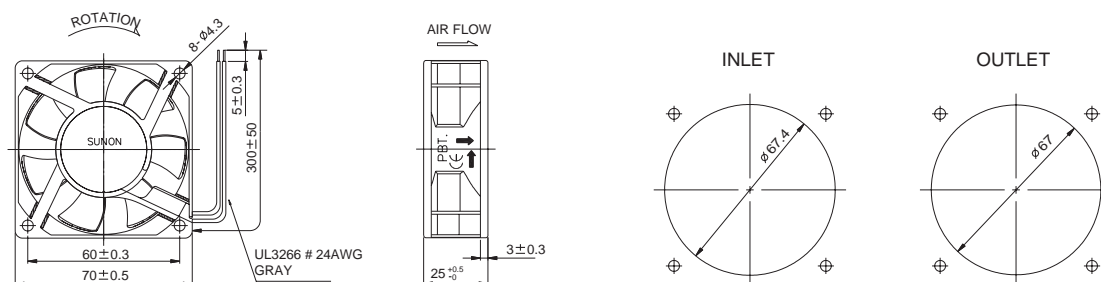

\*The rated current is TRUE RMS current measured by BASE-450(Autoranging Digital V-A-W METER).

\*All model could be customized on voltage or any other requirements to fit your need.

\*Specifications subject to change without notice. Please Visit SUNON web site at <http://www.sunon.com> for update information.