

DN6848/SE/S

Wide operating temperature range (-40°C to $+100^{\circ}\text{C}$)
One-way magnetic field operation

Overview

In each of Hall ICs, a Hall element, an amplifier circuit, a Schmidt circuit, a stabilized power supply, and a temperature compensation circuit are integrated on a single chip by IC technique. The Hall element output is amplified by the amplifier circuit, and converted into the corresponding digital signals through the Schmidt circuit so that TTL and MOS IC are directly drivable.

Features

- High sensitivity and low drift
- Stabilized temperature characteristics owing to additional integration of temperature compensation circuit.
- Wide operating supply voltage range
($V_{CC} = 4.5\text{ V}$ to 16 V)
- One-way magnetic field operation
- TTL and MOS IC are directly drivable by the output.
- Open collector output

Applications

- Speed sensor, position sensor, rotation sensor, keyboard switch, micro switch and the like

Block Diagram (DN6848/SE/S)

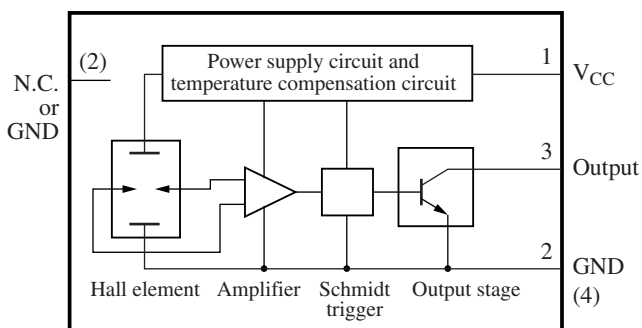

Note) The number in () shows the pin number for the DN6848S.

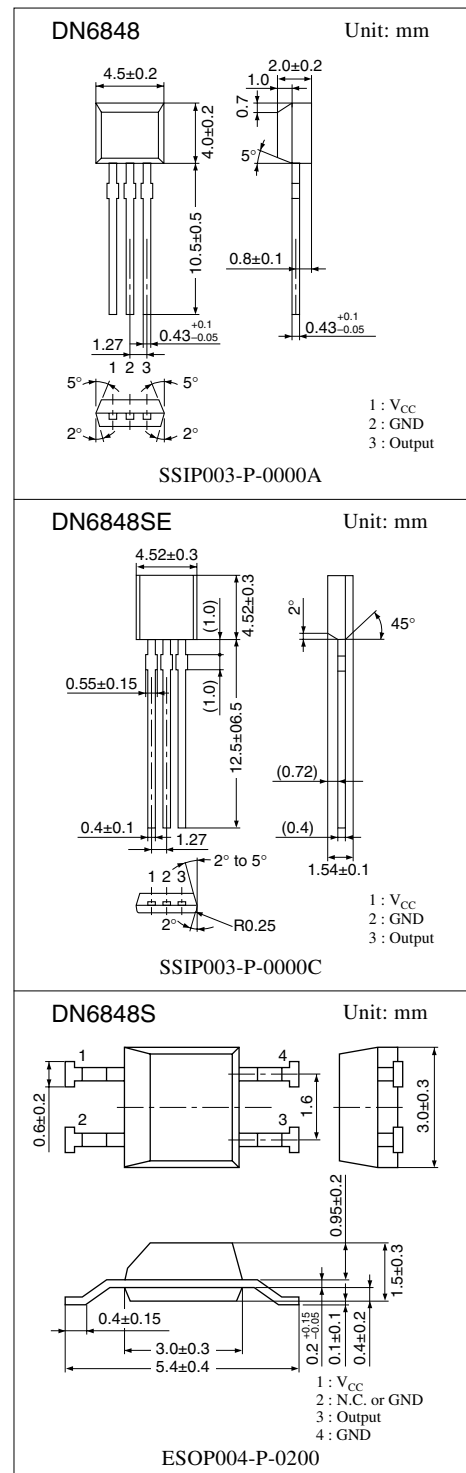

■ Absolute Maximum Ratings

Parameter	Symbol	Rating	Unit
Supply voltage	V_{CC}	18	V
Supply current	I_{CC}	8	mA
Circuit current	I_O	20	mA
Power dissipation	P_D	150	mW
Operating ambient temperature	T_{opr}	-40 to +100	°C
Storage temperature	T_{stg}	-55 to +125	°C

Note) This IC is not suitable for car electrical equipment.

■ Recommended Operating Range

Parameter	Symbol	Range	Unit
Supply voltage	V_{CC}	4.5 to 16	V

■ Electrical Characteristics at $T_a = 25^\circ\text{C}$

Parameter	Symbol	Conditions	Min	Typ	Max	Unit
Operating magnetic flux density	$B_{1(L-H)}$	$V_{CC} = 12\text{ V}$	0.5	9	21	mT
	$B_{2(H-L)}$	$V_{CC} = 12\text{ V}$	1.5	11	22	mT
Hysteresis width	BW	$V_{CC} = 12\text{ V}$	1	2	—	mT
Output voltage	V_{OL}	$V_{CC} = 16\text{ V}, I_O = 12\text{ mA}, B = 22\text{ mT}$	—	—	0.4	V
		$V_{CC} = 4.5\text{ V}, I_O = 12\text{ mA}, B = 22\text{ mT}$	—	—	0.4	V
Output current	I_{OH}	$V_{CC} = 4.5\text{ V to }16\text{ V}, V_O = 16\text{ V}, B = 0\text{ mT}$	—	—	10	μA
Supply current	I_{CC}	$V_{CC} = 16\text{ V}$	—	—	6	mA
		$V_{CC} = 4.5\text{ V}$	—	—	5.5	mA

Note) 1. The variation of operating magnetic flux density does not depend on supply voltage due to its built-in stabilized power source. (V_{CC} should be confined to the range of 4.5 V to 16 V.)

2. A supply current increases by approximately 1 mA when its output level varies from high to low.

■ Technical Data

• Position of Hall element (unit: mm)

A Hall element is placed on the shaded part in the figure.

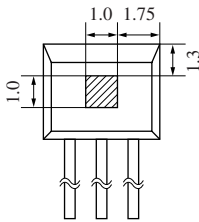
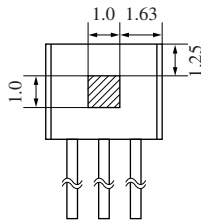
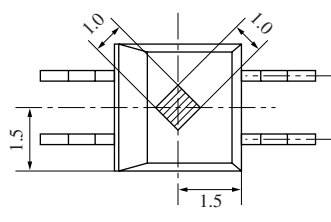
DN6848	DN6848SE	DN6848S
		
Distance from package surface to sensor part		
0.7	0.42	0.65

■ Technical Data (continued)

• Magneto-electro conversion characteristics

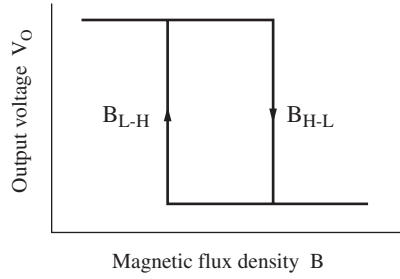
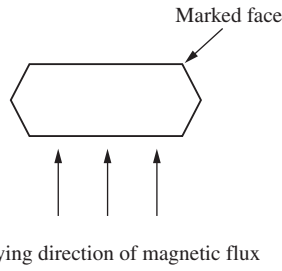

• Main characteristics

Supply current — Ambient temperature

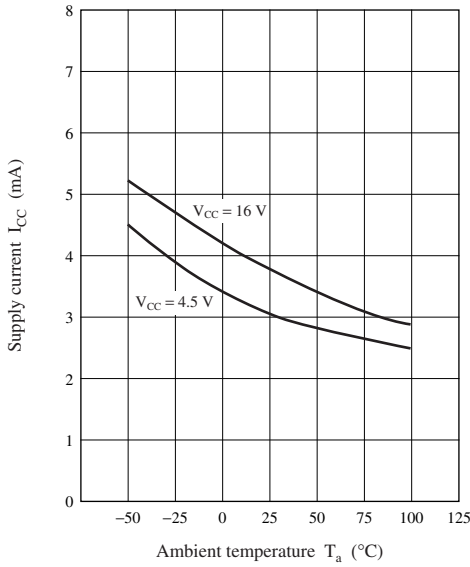

Operating magnetic flux density — Ambient temperature

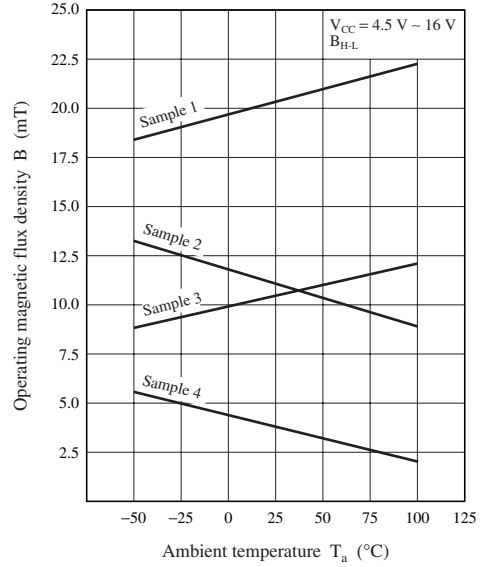

Operating magnetic flux density — Supply voltage

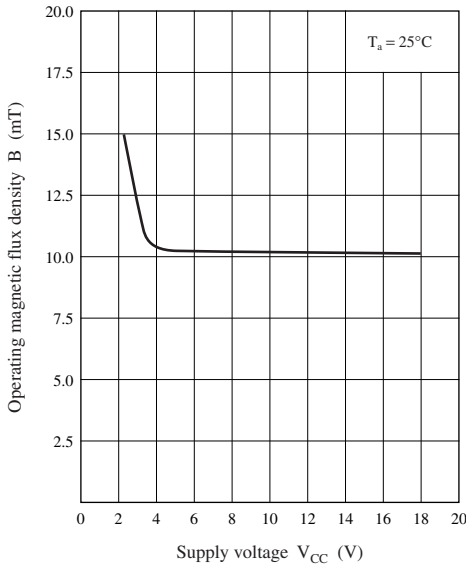

Low-level output voltage — Ambient temperature

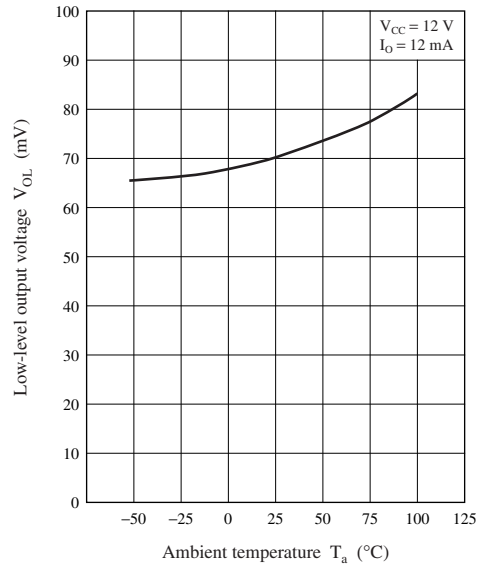

■ Caution on Use of Hall ICs

The Hall ICs are often used to detect movement. In such cases, the position of the Hall IC may be changed by exposition to shock or vibration over a long period of time, and it causes the detection level change. To prevent this, fix the package with adhesives or fix it on a dedicated case.

1. A case using an adhesive

Some kinds of adhesive generate corrosive gas (such as chloric gas) during curing. This corrosive gas corrodes the aluminum on the surface of the Hall IC, and may cause a functional defect of disconnection.

If Hall IC is to be sealed after installation, attention should be given to the adhesive or resin used for peripherals and substrate cleaner, as well as to the adhesive used for Hall IC installation. Please confirm the above matter to those manufacturers before using.

We could not select the specified adhesive, for we find it difficult to guarantee the ingredient of each adhesive.

2. A case bending lead wire

Bend the lead wire without stressing the package.

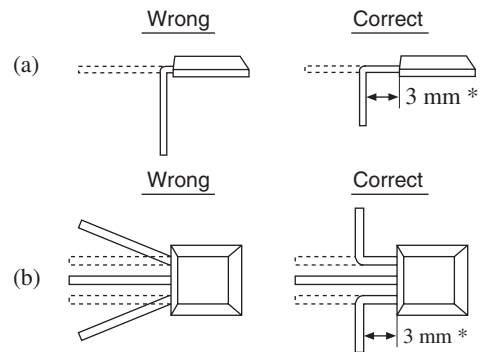
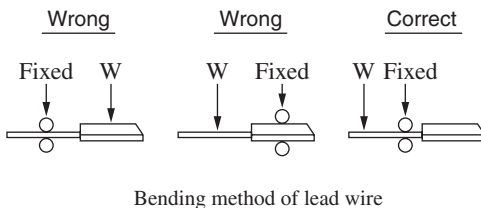

*: The distance can be within 3 mm, if no stress is applied to the resin mold by tightly fixing the lead wires with a metallic mold or the like.

3. Power supply line/Power transmission line

If a power supply line/power transmission line becomes longer, noise and/or oscillation may be found on the line. In this case, set the capacitor of 0.1 μF to 10 μF near the Hall IC to prevent it.

If a voltage of 18 V or more is thought to be applied to the power supply line (flyback voltage from coil or the ignition pulse, etc.), avoid it with external components (capacitor, resistor, Zener diode, diode, surge absorbing elements, etc.).

4. On mounting of the surface mount type package (ESOP004-P-0200)

Set pin 2 of the ESOP004-P-0200 package open, or connect it to GND. The IC will be damaged if it is connected to V_{CC} .

When mounted on the printed circuit board, the Hall IC may be highly stressed by the warp that may occur from the soldering. This may also cause a change in the operating magnetic flux density and a deterioration of its resistance to moisture.



5. V_{CC} and GND

Do not reverse V_{CC} and GND. If the V_{CC} and GND pins are reversely connected, this IC will be destroyed. If the IC GND-pin voltage is set higher than other pin voltage, the IC configuration will become the same as a forward biased diode. Therefore, it will turn on at the diode forward voltage (approximately 0.7 V), and a large current will flow through the IC, ending up in its destruction. (This is common to monolithic IC.)

6. Cautions on power-on of Hall IC

When a Hall IC is turned on, the position of the magnet or looseness may change the output of a Hall IC, and a pulse may be generated. Therefore, care should be given whenever the output state of a Hall IC is critical when the supply power is on.

■ Caution on Use of Hall ICs (continued)

7. Fixing a Hall IC

When the Hall IC of an insertion type package installed by soldering the lead wire only is to be used under vibration, fix it firmly with a holder. Otherwise, vibration may cause metal fatigue in the lead wire of Hall IC, resulting in wire breakage.

8. On fixing a Hall IC to holder

When a Hall IC is mounted on the printed circuit board with a holder and the coefficient of expansion of the holder is large, the lead wire of the Hall IC will be stretched and it may give a stress to the Hall IC.

If the lead wire is stressed intensely due to the distortion of holder or board, the adhesives between the package and the lead wire may be weakened and cause a minute gap resulting in the deterioration of its resistance to moisture.

Sensitivity may also be changed by this stress.

9. On using flux in soldering

Choose a flux which does not include ingredients from halogen group, such as chlorine, fluorine, etc. The ingredients of halogen group may enter where the lead frame and package resin joint, causing corrosion and the disconnection of the aluminum wiring on the surface of an IC chip.

10. In case of the magnetic field of a magnet is too strong

Output may be inverted when applying a magnetic flux density of 100 mT or more. Accordingly, magnetic flux density should be used within the range of 100 mT.

11. On mounting, deburring and soldering of insertion type package

If the leads of a Hall IC in an insertion type package are inserted up to their root part through holes on the printed circuit board, abnormal stress is applied to the package and the reliability of the Hall IC is likely to deteriorate. So, when mounting each Hall IC of the insertion type, insert the leads in due degree at which the bottom face of the package is separated at least 2 mm from the top face of the PCB.

Also note that burrs of epoxy resin may be left sticking to the lead wires. (We are trying to remove such burrs as

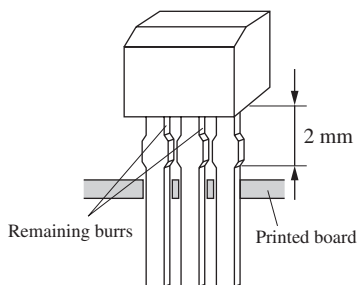

When soldering the leads, remember to separate the soldering position by 2 mm or more from the resin part of the package.

much as possible in the deburring process, but in some cases, they are not perfectly removable.)

12. On surface treatment of mini-mold package

Surface treatment is available in either smooth or dull finish.

13. On soldering of the surface mount type package

Surface mounting type Hall ICs are apt to change its electrical characteristics due to the stress from soldering at mounting. Therefore, avoid the mounting by flow (dipping) and a soldering iron. Please mount it by reflow soldering abiding by its recommended conditions.

Request for your special attention and precautions in using the technical information and semiconductors described in this material

- (1) An export permit needs to be obtained from the competent authorities of the Japanese Government if any of the products or technologies described in this material and controlled under the "Foreign Exchange and Foreign Trade Law" is to be exported or taken out of Japan.
- (2) The technical information described in this material is limited to showing representative characteristics and applied circuit examples of the products. It does not constitute the warranting of industrial property, the granting of relative rights, or the granting of any license.
- (3) The products described in this material are intended to be used for standard applications or general electronic equipment (such as office equipment, communications equipment, measuring instruments and household appliances).
Consult our sales staff in advance for information on the following applications:
 - Special applications (such as for airplanes, aerospace, automobiles, traffic control equipment, combustion equipment, life support systems and safety devices) in which exceptional quality and reliability are required, or if the failure or malfunction of the products may directly jeopardize life or harm the human body.
 - Any applications other than the standard applications intended.
- (4) The products and product specifications described in this material are subject to change without notice for reasons of modification and/or improvement. At the final stage of your design, purchasing, or use of the products, therefore, ask for the most up-to-date Product Standards in advance to make sure that the latest specifications satisfy your requirements.
- (5) When designing your equipment, comply with the guaranteed values, in particular those of maximum rating, the range of operating power supply voltage and heat radiation characteristics. Otherwise, we will not be liable for any defect which may arise later in your equipment.
Even when the products are used within the guaranteed values, redundant design is recommended, so that such equipment may not violate relevant laws or regulations because of the function of our products.
- (6) When using products for which dry packing is required, observe the conditions (including shelf life and after-unpacking standby time) agreed upon when specification sheets are individually exchanged.
- (7) No part of this material may be reprinted or reproduced by any means without written permission from our company.

Please read the following notes before using the datasheets

- A. These materials are intended as a reference to assist customers with the selection of Panasonic semiconductor products best suited to their applications.
Due to modification or other reasons, any information contained in this material, such as available product types, technical data, and so on, is subject to change without notice.
Customers are advised to contact our semiconductor sales office and obtain the latest information before starting precise technical research and/or purchasing activities.
- B. Panasonic is endeavoring to continually improve the quality and reliability of these materials but there is always the possibility that further rectifications will be required in the future. Therefore, Panasonic will not assume any liability for any damages arising from any errors etc. that may appear in this material.
- C. These materials are solely intended for a customer's individual use.
Therefore, without the prior written approval of Panasonic, any other use such as reproducing, selling, or distributing this material to a third party, via the Internet or in any other way, is prohibited.