



LinkCharge™ CT
Datasheet and Installation Guide

WIRELESS CHARGING PRODUCTS

Datasheet and Installation Guide

LinkCharge™ CT Infrastructure Wireless Charging System

SKU: DMTX-19V15W-EZ-SYS

Objectives

This document serves as both a datasheet and an installation guide for the DMTX-19V15W-EZ-SYS wireless charging transmitter. The first two sections provide an overview of the device and an introduction to the underlying Wireless Power standards and concepts. The main body of this text presents a number of factors that help determine a proper location for the charger, and the details of how to properly install the charger beneath a countertop. Following this are the detailed mechanical dimensions of the device and the specifications the device performs to. Answers to some frequently asked questions are provided at the end of the document.

Configuration

When obtained in single unit kit form, the kit will include the charger as well as the power supply for the charger and the power cords associated with the power supply. Bulk orders may be placed for the charger alone, in which case the installer will need to obtain the power supply and cords separately. This document will address both cases, so the user should keep in mind the included items per their order, and plan accordingly.

Table of Contents

1 - Device Overview	2
2 - Wireless Power Technology Overview.....	3
3 - Installation Considerations.....	4
4 - Installation Instructions	5
5 - Mechanical Dimensions	7
6 - Specifications	8
7 - FAQs.....	11

1 - Device Overview

FEATURES

- Supports Qi, PMA and proprietary charging applications
- Power output up to 15W
- Easily mounts under counter or in most non-metallic furniture surfaces
- Determines correct wireless power protocol depending on the receiver
- Requires a 19V @ 2A DC input supply
- Can be daisy-chained on a single power supply for multi-site charging
- LED indicators for power on, charging and error conditions

SPECIFICATIONS

- WPC Qi 1.2.1 compatible
- PMA SR1 compatible
- Compatible with fast charging phones
- 15W power output
- Charges portable devices through up to 10 mm of material thickness

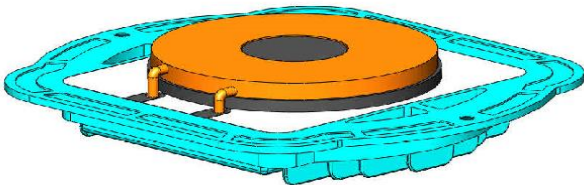

DESCRIPTION

The Infrastructure Transmitter Module is a complete, self-contained system. When paired with a WPC Qi 1.2 compatible receiver above the transmitter coil, the module implements a WPC 1.2.1 wireless charging system with power output up to 15W. When paired with a PMA SR1 compatible receiver above the transmitter coil, the module implements a PMA SR1 wireless charging system also with power output up to 15W. The transmitter will automatically adjust the charging power, based on the requirements of the receiver.

The Infrastructure Transmitter Module contains a custom controller for managing the Qi or PMA protocol and charging functions. The firmware in the non-volatile memory of the microcontroller can be modified to add user-defined functionality for a specific customer application, and for some models, allows upgradeability as standards change and mature.

APPLICATIONS

- Qi, PMA and non-standard wireless chargers for countertop and furniture installations in:
 - Restaurants and Hospitality sites
 - Transportation hubs
 - Industrial applications
 - Educational facilities
 - Hospitals
 - Public Enterprises

MINIMUM SPACING

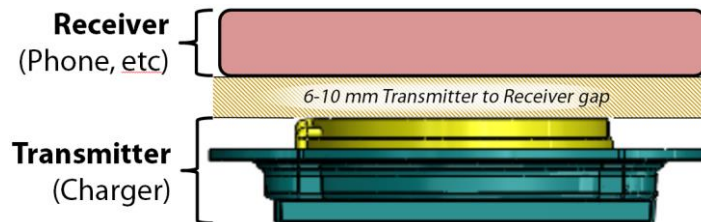

2 - Wireless Power Technology Overview

WPC Qi Operation

When a WPC Qi compatible receiver is placed on the transmitter coil, the Infrastructure Transmitter Module implements a WPC Qi 1.2.1 wireless charging system at up to 15W output. The module will automatically adjust the charging power based on instructions from the receiver. The transmitter LED will illuminate green for ~2 seconds, and then start flashing green; this indicates charging is taking place. If the receiver coil moves too far in relation to the transmitter coil, the LED may illuminate solid red, indicating an error condition. If this (or any other error condition) occurs, remove the receiver from the transmitter, wait for the LED to turn off, and then replace the receiver on the transmitter.

The Infrastructure Transmitter Module contains an algorithm for sensing the presence of additional metal objects placed on the transmitter (foreign object detection). When a metal object is placed on or near the transmitter coil before or during operation, and if the metal object absorbs too much energy from the system, the transmitter will stop transmitting output power and the Error LED will flash red.

PMA Operation

When a PMA compatible receiver is placed above the transmitter coil, the Infrastructure Transmitter Module implements a PMA SR1 wireless charging system at up to 15W output. The module will automatically adjust the charging power based on instructions from the receiver. The transmitter LED will illuminate green for ~2 seconds, and then start flashing green; this indicates charging is taking place. If the receiver coil moves too far in relation to the transmitter coil, the LED may illuminate solid red, indicating an error condition. If this (or any other error condition) occurs, remove the receiver from the transmitter, wait for the LED to turn off, and then replace the receiver on the transmitter.

3 - Installation Considerations

The DMTX-19V15W-EZ-SYS kit contains a wireless charging transmitter, along with the cords and transformer that powers it. Below are instructions for how properly to locate and install this device.

Environmental Considerations

Select a location convenient and accessible for charging. Avoid locating the device where either the transmitter or receiver could get wet, overly hot, or otherwise damaged. Don't locate the transmitter close to the edge of the counter to avoid the risk of the wireless device (smartphone, etc) being accidentally knocked off the countertop and falling to the floor. Select a location with some air flow to allow heat from the operating transmitter to dissipate. If the transmitter is to be replaceable, it should be accessible to facilitate removal and replacement.

Electromagnetic Considerations

Locate the charger at least 1" (25 mm) from any support structure. Assure that no metal is present above the transmitter unit. Provide at least 1.5" (36 mm) of clearance above the charger, and 1" (25 mm) below the unit. If multiple chargers are present, allow at least 6" (150 mm) spacing between each.

Identifying the Location of the Charging Point

Since efficient power transfer relies upon close coupling of the receiver with the transmitter, it is important that the user be able to accurately locate their handheld device directly above the transmitter for charging. As such, consideration should be given to providing some form of location guide on the counter top. The prominence and styling of these visual guides is a matter of installer preference, and should take into consideration the needs of the end user. In a setting where the installation will be well known to a limited number of users, a subtle or even temporary location guide may be sufficient. In settings where users won't be familiar with the location of the charging site, a more prominent marking would likely be preferred, both to identify the availability of the site and the optimal placement for the handheld device to be charged.

Mechanical Details

The charger should be mounted to the underside of a counter top. The installer should verify that the power and micro USB ports are accessible after installation, and should plan for the routing of the DC power supply cable. The installer should also plan for the mounting of the included power transformer. Lastly, the installer should plan for the routing of the AC cable from the transformer to an available AC outlet.

Testing the Charger

Before installing the transmitter, verify its functionality:

1. Apply power and check to see that the green LED blinks once.
2. Place a 6 to 10 mm spacer above the charger coils:
 - spacer can be made of any non-metallic material desired, e.g.: plastic, wood, cardboard, etc.

- Note: never place a receiver in direct contact with the transmitter coil. The minimum allowable spacing is 6mm. Placement closer than this could damage the receiving device and must be avoided at all times. Once installed, this concern is eliminated, but the installer must take this concern into account when testing the device prior to installation.



3. Place a compatible handheld device over the spacer and verify that the device indicates charging has commenced.

4 - Installation Instructions

As noted previously, the transmitter coil must be located between 6 and 8 mm below the top of the counter to provide the correct transmitter to receiver spacing. In most cases, this will require milling a cavity into the underside of the counter into which the charger can be mounted to achieve the correct spacing. The critical depth of cut will be the mounting point for the flanges of the charger, as these will determine the spacing between the transmitter coil and the countertop.

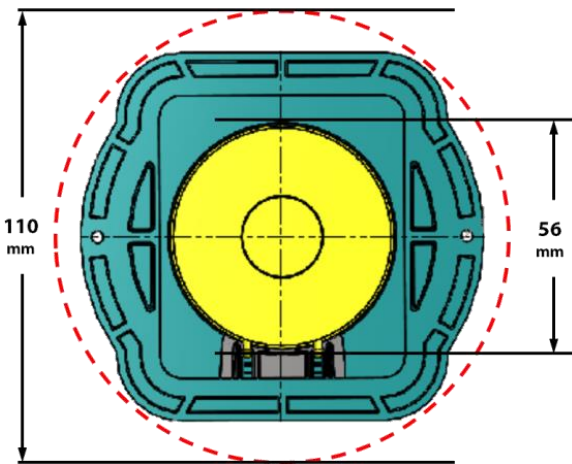

As per the diagram to the left, a circle 110 mm or greater is required for the body of the charger. If the location allows, a circle of 135 mm is recommended, as this will allow easy access to the power and USB ports after the device is installed. In the center of this cutout a further recess should be created to accommodate the coils of the transmitter. This second cut should be a minimum of 56 mm in diameter. A slightly larger diameter of perhaps 60 mm is recommended to reduce the possibility of interference between the charger and the countertop materials. It is also possible to create a cavity that precisely matches the dimensions of the charger, but in most cases, the simpler circular cutouts will do just as well and should be easier to produce and require less sophisticated tools to achieve.

As per the diagram below, the flange cutout should be made to yield a thickness of the countertop material of 13 mm with a tolerance of ± 1 mm. This is the critical measurement that defines the transmitter to receiver spacing, so extra care in obtaining this distance should be exercised. The coil cutout must be at least another 6mm in depth beyond the flange cutout, but the installer may prefer a slightly deeper cut of 7 mm or so to reduce the possibility of interference between the charger and the countertop materials.

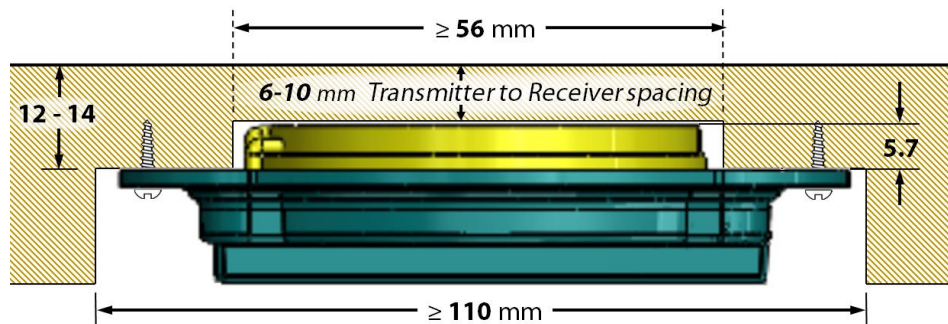

After the pocket is milled out, test-fit the charger and verify that there will be clearance for the power and USB connections. Attach the charger to the underside of the counter with two screws. Screws should be selected for the 2.9 mm diameter mounting holes in the body of the charger, and should be of a length sufficient to pass through the 2 mm flange depth on the charger and provide secure grip into the countertop material while not exceeding the 12-14 mm thickness of the countertop in this location.

Silicone adhesive may also be used to attach the charger, but in most cases is an inferior solution to the use of the recommended mounting screws. Screws allow for easier removal of the device if required, and are more reliable than adhesive, which could weaken over time and allow the device to detach and fall. Use of silicone adhesive requires extra care to apply the material only onto the flange body to avoid getting any on the coil apparatus itself, which is not intended to be a mounting structure.

Wiring

The transmitter kit includes a power supply compatible with the charger. If a volume purchase did not include the supply, one must be obtained that meets the following specifications: 19 \pm 1.5 V DC input supply, 1.32 A (or greater) with a plug at the end of the DC line per the diagram below:

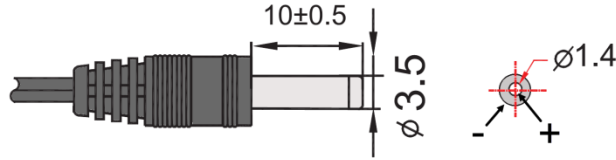

When planning the mounting the transmitter, attention should also be given to how the power cord(s) will be routed. While the cord could simply be plugged into the charger and allowed to drape to the floor, embedding the cord within the counter or attaching it to the underside of the counter should allow for greatly improved ergonomics, reliability, and aesthetics. It may be optimal to cut a shallow channel into the underside of the counter to route the cabling through, so as to minimize the chance of the cord interfering with anything below the counter. This is not a consideration unique to this charger, so the installer should determine the cable routing as they would any other similar power cable.

LED Indicator

The LED present on the side of the transmitter indicates the state of the device. During device test, it can easily be observed, but when mounted beneath a countertop it is not normally visible. If desired, the installer could use a length of fiber optic cable to route the light from the LED to a location visible after installation. Normally, the device being charged will display the charging status, so the need for status provided by the transmitter LED may be redundant. Below is a table defining the various LED displays:

No Light	Charger Off or Standby
One Green Flash	Power Applied, Device Initialized
Continuous Flashing Green Light	Charging Cycle Underway
Steady Green Light	Charge Complete
Flashing Red Light	Foreign Object in Charging Field – Remove Object, Restart Charging
Steady Red Light	Error – Remove and Replace Receiver

Firmware Update Procedure

Should new firmware be developed for this device, it will be made available at www.semtech.com. A search for DMTX-19V15W-EZ-SYS will lead to the support page for the device where any available driver updates will be found. Also download the TS8000X GUI, found by searching on TS80000 and clicking on the Docs and Resources tab. Install the GUI on your PC then connect the PC to the charger via a USB (USB 2.0 Micro Type-B) cable. Drag the firmware file onto the FW_FLASH icon. FW_FLASH will open a window on your PC. In the FW_FLASH window, the utility will indicate the progress of the flash update. The update requires only a few seconds, at which time the USB cable can be removed and the update process is complete.

5 - Mechanical Dimensions

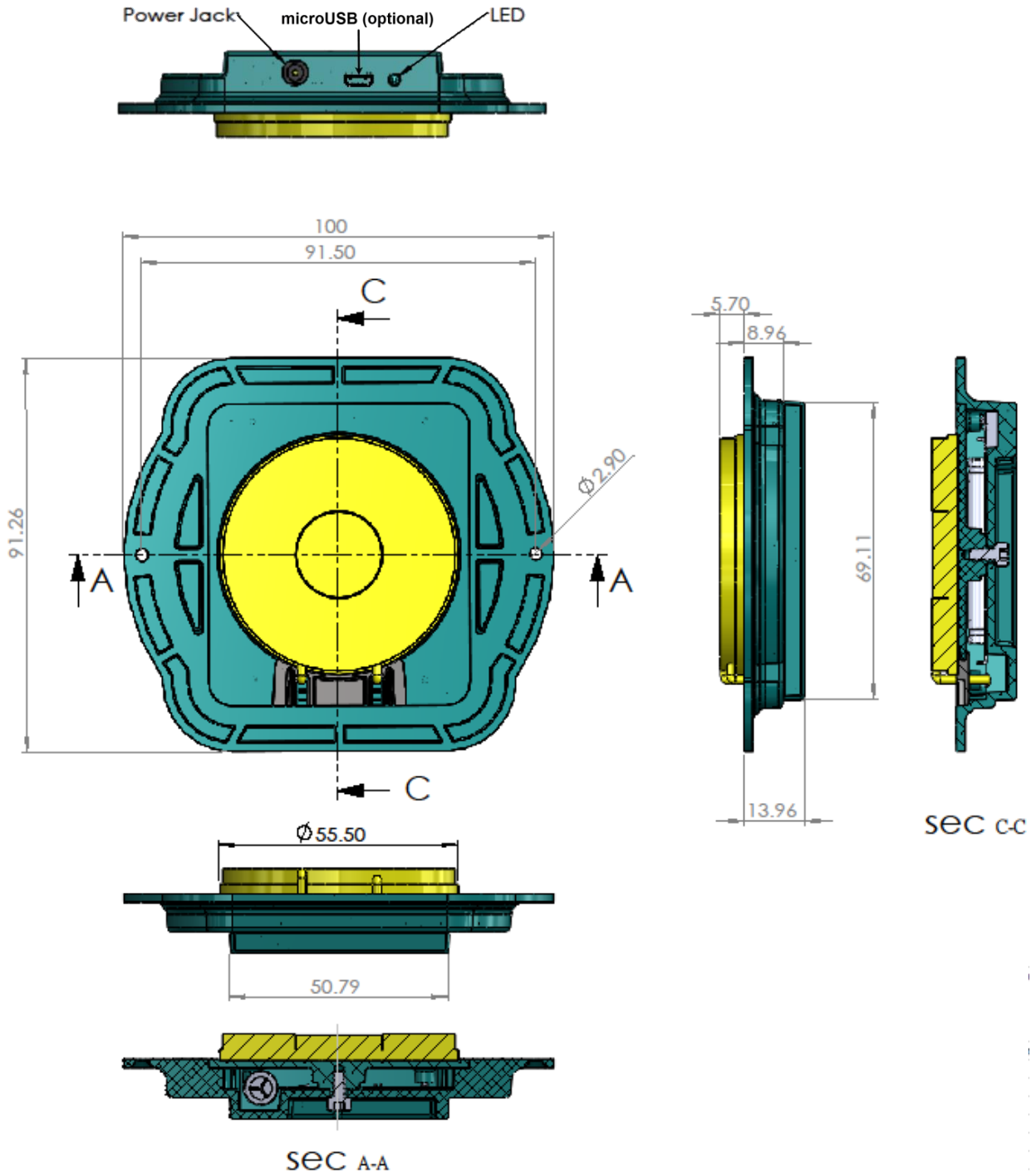

6 - Specifications

Mechanical Specifications

- Length 91.26 mm
- Width 82 mm
- Spacer Thickness of material
- Coil Type Custom

Electrical Specifications

- DC Input 19 +/-1.5 V DC input supply, 1.32 A (min)
- USB Port Firmware Update Input
- LED Indicates: off or standby (no LED), powerup (single green flash), charging (green flashing), end-of-charge (green solid), foreign object detect (red flashing), or error condition (red solid) per Qi specification

Temperature

- Operating ambient / Normal mode ambient: +0°C min / +30°C max
- Non-operating ambient: -40°C to +70°C (maximum rate of change of 20°C/hour)

Humidity

- Operating: to 85% relative humidity (non-condensing)
- Non-Operating: to 95% relative humidity (non-condensing)

Altitude

- Operating: to 5,000 ft.
- Non-operating: to 50,000 ft.

Mechanical Shock

- Non-operating: 50 G trapezoidal wave, velocity change = 170 in/sec
- Three drops in each of six directions are applied to each of the samples

Random Vibration

Non-operating

Sine sweep: 5Hz to 500Hz @ 0.5gRMS at 0.5 octave/min; dwell 15 min at each of 3 resonant points

Random profile: 5Hz @ 0.01g²/Hz to 20Hz @ 0.02g²/Hz (slope up); 20Hz to 500Hz @ 0.02g²/Hz (flat); Input acceleration = 3.13gRMS; 10 min. per axis for 3 axis on all samples

Thermal Shock (Shipping)

Non-operating: -40°C to +70°C, 50 cycles, 30°C/min ≥ transition time ≥ 15°C/min; duration of exposure to temperature extremes for each half cycle shall be 30 minutes

Safety Agency Test Results

As outlined in the following sections, Product Regulatory Requirements, the manufacturer will provide complete copies of all safety agency reports and data submitted to the safety agencies. A copy of any additional data gathered but not included in the data submitted to the safety agencies shall also be provided.

These tests shall be completed at all full rated load conditions, with the DC voltage margined, per typical safety agency test requirements (i.e. -10% and +6%). The system is operated at maximum ambient temperature during this series of tests.

Reliability / Warranty / Service

Component De-rating

The following component de-rating guidelines shall be followed. Any exceptions are subject to final approval.

- Semiconductor junction temperatures shall not exceed 110°C
- Transformer temperature shall not exceed 110°C
- Inductor case temperature shall not exceed 85% of rated temperature in °C
- Capacitor case temperature shall not exceed 85% of rated temperature in °C
- Resistor wattage de-rating shall be > 30%
- Component voltage and current de-rating shall be > 15%. During abnormal conditions (such as a short circuit) no de-rating is required as long as the max rating is not exceeded.

Component Life requirement

All components life expectancy requirement is min 3 years, calculated at 75% of max continuous load @ 40°C ambient temperature and @ 19V DC voltage.

Investigative Life Requirement

The system shall support a 5 year calculated life with a 90% confidence under the following conditions:

- 100 - 240VAC input
- 50°C ambient temperature
- 50% of the time at 20% load; 50% of the time at 80% load

Mean Time between Failures (MTBF)

The system shall have a minimum MTBF at continuous operation of

1. 100,000 hours at 75% load and 40°C, as **calculated** by Bell core RPP, or
2. 250,000 hours **demonstrated** at 75% load and 40°C

Warranty Period

Two (2) years EU, one (1) year rest of the world.

Serviceability

No troubleshooting by maintenance personnel is to be performed. Only unit replacement will be done in the field.

Modifications / Change Control

Following the qualification of the system, any changes in parts, materials, or processes used in system manufacturer which affect form, fit, function, safety, reliability (Type One changes), or documentation of the power device (Type Two changes) must be approved by customer prior to the incorporation of such changes.

Product Regulatory Requirements

Intended Application: This product is intended for indoor use only.

Product Safety

IEC60950-1 (International)

Product EMC Compliance – Class B Compliance

Note: The product is required to comply with Class B emission requirements as the end system that it is configured into is intended for a commercial environment and market place. System is to have minimum of 3db margin to Class B Limits.

FCC /ICES-003 - Emissions (USA/Canada) Verification

CISPR 22 – Emissions (International)

EN55022 - Emissions (Europe)

EN55024 - Immunity (Europe)

- EN61000-4-2 Electrostatic Discharge
- EN61000-4-3 Radiated RFI Immunity
- EN61000-4-4 Electrical Fast Transients
- EN61000-4-5 Electrical Surge
- EN61000-4-6 RF Conducted
- EN61000-4-8 Power Frequency Magnetic Fields
- EN61000-4-11 Voltage Dips and Interruptions

*EN61000-3-2 - Harmonics (Europe)

*EN61000-3-3 - Voltage Flicker (Europe)

CE – EMC Directive 89/336/EEC (Europe)

*Refer to detailed Harmonic Requirements and Table 1

Certifications / Registrations / Declarations

UL Certification (US/Canada)

CE Declaration of Conformity (CENELEC Europe)

FCC/ICES-003 Class C Attestation (USA/Canada)

7 - FAQs

Q: Can the transmitter be tested by placing a compatible phone on top of the device?

A: No. A minimum spacing of 6 mm is required between the transmitter (charger) and receiver (phone, etc.). Placing a phone directly on top of the receiver can damage the phone and must not be attempted. Once mounted 6 to 8 mm below a countertop, this requirement will be met, and will be of no further concern. The only time extra care must be exercised is when the transmitter is not installed beneath a counter. At these times, if the transmitter is to be used or tested, the operator must assure that a nonmetallic 6 to 8 mm spacer is applied between the transmitter and receiver.

Q: Does this product include the power supply and power cords?

A: The DMTX-19V15W-EZ-SYS kit does include these items; however, future offerings of this device may include a non-kit 'device only' version. The installer will need to provide their own power source when purchasing this version.

Q: Can I attach the transmitter to the counter with silicone adhesive rather than using screws?

A: Silicone adhesive is an option, but in most cases is an inferior solution to the use of the recommended mounting screws. Screws allow for easier removal of the device if required, and are more reliable than adhesive, which could weaken over time and allow the device to detach and fall. Use of silicone adhesive requires extra care to apply the material only onto the flange body to avoid getting any on the coil apparatus itself, which is not designed to be a mounting structure.

Q: What is the recommended thickness of the countertop?

A: The countertop can be any thickness desired, as long as the critical 6-8 mm coil to countertop spacing is provided. Note that a charger embedded in a 1" (25 mm) countertop will be nearly flush with the bottom of the countertop surface once installed, which may be an attractive consideration.

Q: Do all the transmitters include the USB port?

A: All later production runs of the DMTX-19V15W-EZ-SYS include a USB port. The gray-colored first run of about 100 devices did not. They are otherwise functionally identical to the later black-colored models, but cannot be easily updated with new firmware. This may not be a concern in most cases, as the current firmware works well, and major updates are not anticipated. However, if this is a concern, a simple inspection of the device will determine if the USB port is present or not.

Q: What if my questions weren't answered here?

A: Go to the Semtech website at: <http://semtech.com/wireless-charging>. This is where all available information on Semtech's Wireless Charging products can be found. Your local Semtech FAE can also assist in answering your questions.



IMPORTANT NOTICE

Information relating to this product and the application or design described herein is believed to be reliable, however such information is provided as a guide only and Semtech assumes no liability for any errors in this document, or for the application or design described herein. Semtech reserves the right to make changes to the product or this document at any time without notice. Buyers should obtain the latest relevant information before placing orders and should verify that such information is current and complete. Semtech warrants performance of its products to the specifications applicable at the time of sale, and all sales are made in accordance with Semtech's standard terms and conditions of sale.

SEMTECH PRODUCTS ARE NOT DESIGNED, INTENDED, AUTHORIZED OR WARRANTED TO BE SUITABLE FOR USE IN LIFE-SUPPORT APPLICATIONS, DEVICES OR SYSTEMS, OR IN NUCLEAR APPLICATIONS IN WHICH THE FAILURE COULD BE REASONABLY EXPECTED TO RESULT IN PERSONAL INJURY, LOSS OF LIFE OR SEVERE PROPERTY OR ENVIRONMENTAL DAMAGE. INCLUSION OF SEMTECH PRODUCTS IN SUCH APPLICATIONS IS UNDERSTOOD TO BE UNDERTAKEN SOLELY AT THE CUSTOMER'S OWN RISK. Should a customer purchase or use Semtech products for any such unauthorized application, the customer shall indemnify and hold Semtech and its officers, employees, subsidiaries, affiliates, and distributors harmless against all claims, costs damages and attorney fees which could arise.

The Semtech name and logo are registered trademarks of the Semtech Corporation. All other trademarks and trade names mentioned may be marks and names of Semtech or their respective companies. Semtech reserves the right to make changes to, or discontinue any products described in this document without further notice. Semtech makes no warranty, representation or guarantee, express or implied, regarding the suitability of its products for any particular purpose. All rights reserved.

© Semtech 2016

Contact Information

Semtech Corporation
Triune Products
1101 Resource Drive, Suite 121, Plano, Texas 75074
E-mail: sales@semtech.com Phone: 972-231-1606
www.semtech.com