

## DLP® DLPA200 DMD Micromirror Driver

Check for Samples: [DLPA200](#)

### FEATURES

- Designed for Use as a Part of a DLP Chipset
- Generates the Micromirror Clocking Pulses Required by the DLP Digital Micromirror Device (DMD)
- Generates Specialized Voltage Levels Required for Micromirror Clocking Pulse Generation
- Operates From a Single 12-V Power Supply
- Provides a  $V_{BIAS}$  Voltage Level, Used by the DMD to Control the Array Border Mirrors
- Provides a  $V_{OFFSET}$  Voltage Level, Used by the DMD as DMDVCC2
- All Logic Inputs are LVTTTL and CMOS Compatible
- Packaged in an Pb-Free Thermally Enhanced Surface-Mount Package: 80-pin, 0.5 mm-Pitch, Enlarged Terminal Pitch, Thin Profile Quad Flat Pack (eTQFP)

### APPLICATIONS

- **Industrial:**
  - Direct Imaging Lithography
  - Laser Marking and Repair Systems
  - Computer-to-Plate Printers
  - Rapid Prototyping Machines and 3D Printers
  - 3D Scanners for Machine Vision and Quality Control
- **Medical:**
  - Phototherapy Devices
  - Ophthalmology
  - Vascular Imaging
  - Hyperspectral Imaging
  - 3D Scanners for Limb and Skin Measurement
  - Confocal Microscopes
- **Display:**
  - 3D Imaging Microscopes
  - Intelligent and Adaptive Lighting
  - Augmented Reality and Information Overlay

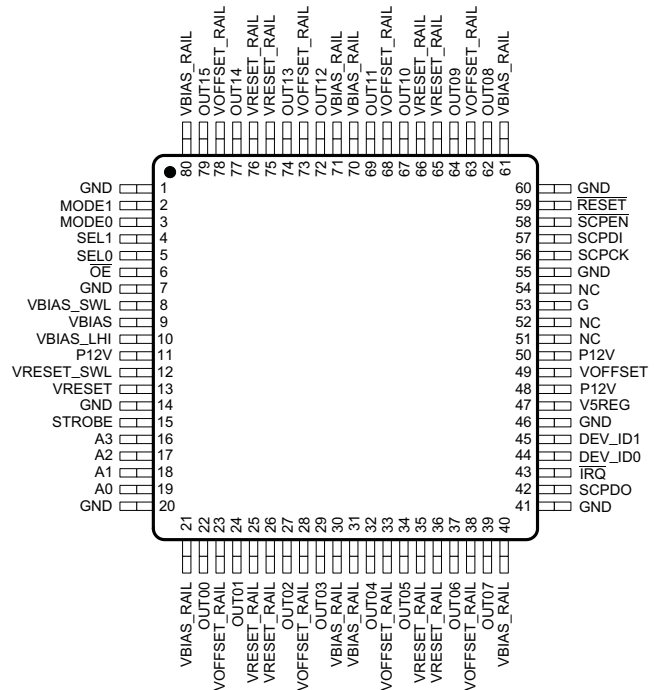
**ETQFP PACKAGE  
(TOP VIEW)**

### DESCRIPTION

The DLPA200 is a DMD Micromirror Driver that is one of multiple components in a DLP chipset. A dedicated DLP chipset provides developers easier access to the DMD as well as high speed micromirror control.



Please be aware that an important notice concerning availability, standard warranty, and use in critical applications of Texas Instruments semiconductor products and disclaimers thereto appears at the end of this data sheet.

DLP is a registered trademark of Texas Instruments.



These devices have limited built-in ESD protection. The leads should be shorted together or the device placed in conductive foam during storage or handling to prevent electrostatic damage to the MOS gates.

## DESCRIPTION CONTINUED

Table 1 is a list of chipsets supported by DLPA200.

**Table 1. Supported DLP Chipset Configurations**

0.55 XGA Chipset			0.7 XGA Chipset			0.95 1080p Chipset		
Qty	TI Part	Description	Qty	TI Part	Description	Qty	TI Part	Description
1	DLP5500	0.55 XGA S450 DMD(digital micromirror device)	1	DLP7000	0.7 XGA Type A DMD(digital micromirror device)	1	DLP9500	0.95 1080p Type A DMD(digital micromirror device)
1	DLPC200	DMD Controller for DLP5500	1	DLPC410	DLP Discovery 4100 DMD Controller	1	DLPC410	DLP Discovery 4100 DMD Controller
			1	DLPR410 /DLPR4101	DLP Discovery 4100 Configuration PROM			
1	DLPA200	DMD Micromirror Driver	1	DLPA200	DMD Micromirror Driver	2	DLPA200	DMD Micromirror Driver

Reliable function and operation of the DLPA200 requires that it be used in conjunction with the other components of the chipset. It is typical for the DMD Controller to operate the DMD Micromirror Driver. For more information on the chipset components the DLP 0.55 XGA Chipset Datasheet or DLP Discovery 4100 Chipset Datasheet.

The DLPA200 consists of three functional blocks: A High-Voltage Power Supply function, a DMD Micromirror Clock Generation function, and a Serial Communication function.

The High-Voltage Power Supply function generates three specialized voltage levels:  $V_{BIAS}$  (19 to 28 V),  $V_{RESET}$  (–19 to –28 V), and  $V_{OFFSET}$  (4.5 to 10 V).

The Micromirror Clock Generation function uses the three voltages generated by the High-Voltage Power Supply function to create the sixteen micromirror clock pulses (output the OUTx pins of the DLPA200).

The Serial Communication function allows the chipset Controller to: control the generation of  $V_{BIAS}$ ,  $V_{RESET}$ , and  $V_{OFFSET}$ ; control the generation of the micromirror clock pulses; status the general operation of the DLPA200.

Functional Block Diagram

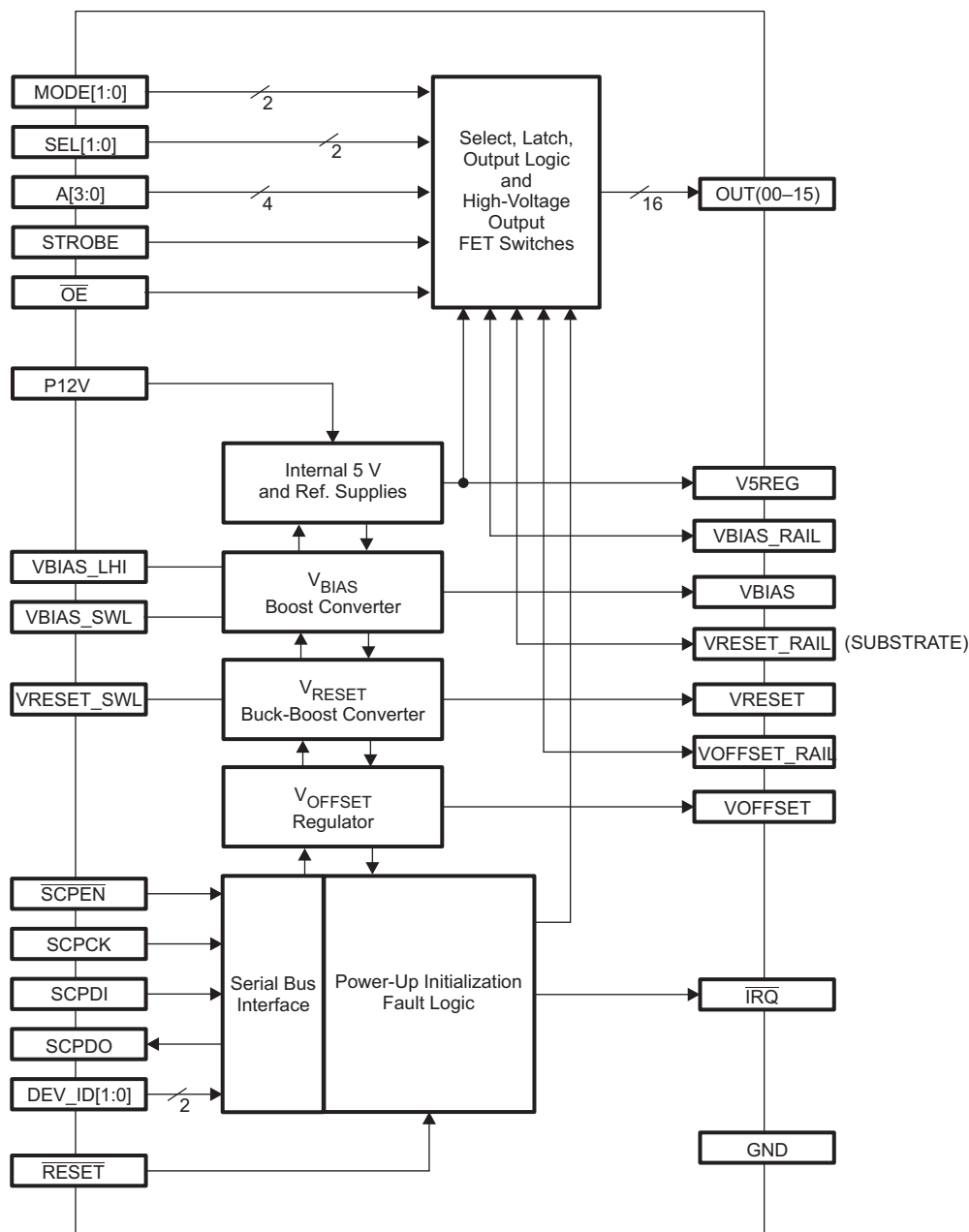

Table 2. Device Configurations

DMD	POWER AND MIRROR CLOCKING PULSE DRIVER	DIGITAL CONTROLLER
DLP9500 (0.95 1080p Type A DMD)	DLPA200 (x2)	DLPC410
DLP7000 (0.7 XGA Type A DMD)	DLPA200	
DLP5500 (0.55 XGA S450 DMD)	DLPA200	

## RELATED DOCUMENTS

Table 3. Related Documentation

Document	TI Literature Number
DLP 0.55 XGA Chip-Set data sheet	<a href="#">DLPZ004</a>
DLP5500 0.55 XGA DMD data sheet	<a href="#">DLPS013B</a>
DLPC200 Digital Controller data sheet	<a href="#">DLPS014</a>
DLP® Discovery™ 4100 Chipset Datasheet	<a href="#">DLPU008</a>
DLP7000 0.7 XGA Type-A DMD data sheet	<a href="#">DLPS026</a>
DLP9500 0.95 1080p Type-A DMD data sheet	<a href="#">DLPS025</a>
DLPC410 Digital Controller data sheet	<a href="#">DLPS024</a>
DLPA200 DMD Micromirror Driver data sheet	<a href="#">DLPS015</a>
DLPR410 EEPROM data sheet	<a href="#">DLPS027</a>

## Device Marking

The device marking consists of the fields shown in [Figure 1](#).

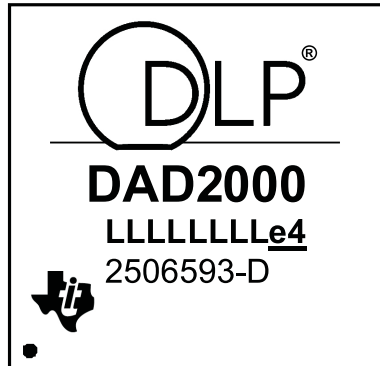

### PART MARKING CODES

LLLLLLLL = Lot trace code or date code

e4 = Pb-Free NiPdAu terminal finish

● = Pin 1 designator

2506593 = TI internal part number

D = revision letter

**Figure 1. Device Marking (Device Top View)**

DLPA200PFP is functionally equivalent to 2506593-0005N.

### TERMINAL FUNCTIONS

TERMINAL		I/O (INPUT DEFAULT)	DESCRIPTION
NAME	NO.		
OUT00	22	Output	16 micromirror clocking waveform outputs (enabled by $\overline{OE} = 0$ ).
OUT01	24	Output	
OUT02	27	Output	
OUT03	29	Output	
OUT04	32	Output	
OUT05	34	Output	
OUT06	37	Output	
OUT07	39	Output	
OUT08	62	Output	
OUT09	64	Output	
OUT10	67	Output	
OUT11	69	Output	
OUT12	72	Output	
OUT13	74	Output	
OUT14	77	Output	
OUT15	79	Output	
A0	19	Input (pull down)	Output Address. Used to select which OUTxx pin is active at a given time.
A1	18	Input (pull down)	
A2	17	Input (pull down)	
A3	16	Input (pull down)	
MODE0	3	Input (pull down)	Mode Select. Used to determine the operating mode of the DLPA200.
MODE1	2	Input (pull down)	
SEL0	5	Input (pull down)	Output Voltage Select. Used to switch the voltage applied to the addressed OUTxx pin.
SEL1	4	Input (pull down)	
STROBE	15	Input (pull down)	A rising edge on STROBE latches in the control signals after a tri-state delay.
$\overline{OE}$	6	Input (pull up)	Asynchronous input controls whether the 16 OUTxx pins are active or are in a high-impedance state. $\overline{OE} = 0$ : Enabled. $\overline{OE} = 1$ : High Z.
$\overline{RESET}$	59	Input (pull up)	Resets the DLPA200 internal logic. Active low. Asynchronous.

**TERMINAL FUNCTIONS (continued)**

TERMINAL		I/O (INPUT DEFAULT)	DESCRIPTION
NAME	NO.		
$\overline{\text{SCPEN}}$	58	Input (pull up)	Enables serial bus data transfers. Active low.
SCPDI	57	Input (pull down)	Serial bus data input. Clocked in on the falling edge of SCPCK.
SCPCK	56	Input (pull down)	Serial bus clock. Provided by chipset Controller.
SCPDO	42	Output	Serial bus data output (open drain). Clocked out on the rising edge of SCPCK. A 1k $\Omega$ pull up resistor to the Chip-Set Controller V <sub>DD</sub> supply is recommended.
$\overline{\text{IRQ}}$	43	Output	Interrupt request output to the chipset Controller. Active low. A 1 k $\Omega$ pull up resistor to the Chip-Set Controller V <sub>DD</sub> supply is recommended.
DEV_ID1	45	Input (pull up)	Serial bus device address: 00 = all; 01 = device 1; 10 = device 2; 11 = device 3.
DEV_ID0	44	Input (pull up)	
VBIAS	9	Output	One of three specialized voltages which are generated by the DLPA200.
VBIAS_LHI	10	Input	Current limiter output for VBIAS supply. (also the VBIAS switching inductor input)
VBIAS_SWL	8	Input	Connection point for VBIAS supply switching inductor.
VBIAS_RAIL	21, 30, 31, 40, 61, 70, 71, 80	Input	The internally-used VBIAS supply rail. Internally isolated from VBIAS.
VRESET	13	Output	One of three specialized voltages which are generated by the DLPA200. The package thermal pad is tied to this voltage level.
VRESET_SWL	12	Input	Connection point for VRESET supply switching inductor..
VRESET_RAIL <sup>(1)</sup>	25, 26, 35, 36, 65, 66, 75, 76	Input	The internally-used VRESET supply rail. Internally isolated from VRESET. <sup>(1)</sup>
VOFFSET	49	Output	One of three specialized voltages which are generated by the DLPA200.
VOFFSET_RAIL	23, 28, 33, 38, 63, 68, 73, 78	Input	The internally-used VOFFSET supply rail. Internally isolated from VOFFSET.
GND	1, 7, 14, 20, 41, 46, 53, 55, 60	GND	Common ground
V5REG	47	Output	The 5-volt logic supply output.
P12V	11, 48, 50	Input	The main power input to the DLPA200.
NC	51, 52, 54	No Connect	No connect

(1) Exposed thermal pad is internally connected to VRESET\_RAIL.

## ABSOLUTE MAXIMUM RATINGS

over operating free-air temperature range (unless otherwise noted). Stresses beyond those listed under "[Absolute Maximum Ratings](#)" may cause permanent damage to the device. The [Absolute Maximum Ratings](#) are stress ratings only, and functional performance of the device at these or any other conditions beyond those indicated under "[Recommended Operating Conditions](#)" is not implied. Exposure to Absolute Maximum Rated conditions for extended periods may affect device reliability.

CONDITIONS		MIN	TYP	MAX	UNIT
Load supply voltage, P12V				14	V
Reset supply switching inductor connection point, VRESET_SWL	Measured with respect to VRESET_RAIL			-1	V
Internally-used V <sub>BIAS</sub> supply rail, VBIAS_RAIL	Measured with respect to VRESET_RAIL			60	V
Internally-used V <sub>OFFSET</sub> supply rail, VOFFSET_RAIL	Measured with respect to VRESET_RAIL			40.5	V
Logic inputs, V <sub>IN</sub>		-0.3		7	V
Open drain logic outputs, V <sub>OUT</sub>				7	V
Maximum junction temperature, T <sub>J</sub>				125	°C
Operating temperature range, T <sub>A</sub>		0		75	°C
Storage temperature range, T <sub>S</sub>		-55		150	°C
Thermal resistance, R <sub>cj</sub>	V <sub>BIAS</sub> = 26 V, V <sub>RESET</sub> = -26 V, V <sub>OFFSET</sub> = 10 V, Output load = 390 pF and 39R on each output, Phase by one with global mode, Channel repetition frequency = 50 kHz, Additional external loads: I <sub>BIAS</sub> = 5 mA, I <sub>OFFSET</sub> = 30 mA, I <sub>5REG</sub> = 30 mA		3		°C/W
ESD	Human Body Model			2	kV
	Charge Device Model			800	V

## RECOMMENDED OPERATING CONDITIONS

at  $T_A = 25^\circ\text{C}$ , P12V = 10.8 V to 13.2 V (unless otherwise noted). The functional performance of the device specified in this data sheet is achieved when operating the device within the limits defined by the [Recommended Operating Conditions](#). No level of performance is implied when operating the device above or below the [Recommended Operating Conditions](#) limits.

PARAMETER		TEST CONDITIONS	MIN	TYP	MAX	UNIT
Power						
$I_{P12V1}$	P12V supply current <sup>(1)</sup>	Global shadow at 50 kHz, OUT load = 39 $\Omega$ and 390 pF, V5REG = 30 mA, V <sub>BIAS</sub> = 26 V at 5 mA, V <sub>OFFSET</sub> = 10V at 30 mA, V <sub>RESET</sub> = -26 V		200		mA
$I_{P12V2}$		Outputs disabled and no external loads, V <sub>BIAS</sub> = 19 V, V <sub>OFFSET</sub> = 4.5 V, V <sub>RESET</sub> = -19 V			22	mA
$T_{JTSDR}$	Thermal shutdown temperature	With device temperature rising	145	160	175	$^\circ\text{C}$
		Hysteresis	5	10	15	$^\circ\text{C}$
	Delta between thermal shutdown and thermal warning		5	10	15	$^\circ\text{C}$
$T_{JTWR}$	Thermal warning temperature	With device temperature rising	125	140	155	$^\circ\text{C}$
		Hysteresis	5	10	15	$^\circ\text{C}$

(1) During power up the inrush power supply current can be as high as 1 A for a momentary period of time.

## ELECTRICAL CHARACTERISTICS

### Control Logic

$T_A = 25^\circ\text{C}$ , P12V = 10.8 V to 13.2 V (unless otherwise noted)

PARAMETER		TEST CONDITIONS	MIN	TYP	MAX	UNIT
$V_{IL}$	Low-level logic input voltage				0.8	V
$V_{IH}$	High-level logic input voltage		1.97			V
$I_{IH}$	High-level logic input current	V <sub>IN</sub> = 5 V, input with pulldown. See terminal functions table.		40	50	$\mu\text{A}$
$I_{IL}$	Low-level logic input current	V <sub>IN</sub> = 0 V, input with pullup. See terminal functions table.	-50	-40		$\mu\text{A}$
$I_{IH}$	High-level logic input leakage current	V <sub>IN</sub> = 0 V, input with pulldown	-1		1	$\mu\text{A}$
$I_{IL}$	Low-level logic input leakage current	V <sub>IN</sub> = 5 V, input with pullup	-1		1	$\mu\text{A}$
$V_{OL}$	Open drain logic outputs	I = 4 mA			0.4	V
$I_{OL}$	Logic output leakage current	V = 3.3 V			1	$\mu\text{A}$

## ELECTRICAL CHARACTERISTICS

### 5-V Linear Regulator

$T_A = 25^\circ\text{C}$ , P12V = 10.8 V to 13.2 V (unless otherwise noted)

PARAMETER		TEST CONDITIONS	MIN	TYP	MAX	UNIT
$V_{5REG}$	Output voltage	Average voltage, I <sub>OUT</sub> = 4 mA to 50 mA	4.75	5	5.25	V
$I_{IL}$	Output current: internal logic		4		20	mA
$I_{IE}$	Output current: external circuitry		0		30	mA
$I_{CL5}$	Current limit		80			mA
$V_{UV5}$	Undervoltage threshold	I <sub>OUT</sub> = 50 mA	V5REG voltage increasing, P12V = 5.4 V	4.1		V
			V5REG voltage falling, P12V = 5.2 V		3.9	
$V_{RIP}$	Output ripple voltage <sup>(1)</sup>				200	mVpk-pk
$V_{OSS}$	Voltage overshoot at start up				2	%V5REG
$t_{ss}$	Power up	Measured between 10 to 90% of V5REG			1	ms

(1) Output ripple voltage relies on suitable external components being selected and good printed circuit board layout practice.

## ELECTRICAL CHARACTERISTICS

### Bias Voltage Boost Converter

T<sub>A</sub> = 25°C, P12V = 10.8 V to 13.2 V (unless otherwise noted)

PARAMETER		TEST CONDITIONS	MIN	TYP	MAX	UNIT
I <sub>RL</sub>	Output current: reset outputs	Load = 400pF, 39 Ω, repetition frequency = 50 kHz	0		18	mA
I <sub>QL</sub>	Output current: quiescent / drivers	Load = 400 pF, 39 Ω, repetition frequency = 50 kHz			3	mA
I <sub>DL</sub>	Output current: DMD load		0		5	mA
I <sub>CLFB</sub>	Current limit flag	Corresponding current on output at P12V = 10.8 V	30			mA
I <sub>CLB</sub>	Current limit	Measured on input	330	376	460	mA
V <sub>BIAS</sub>	Output voltage		25.5	26	26.5	V
V <sub>UVB</sub>	V <sub>BIAS</sub> undervoltage threshold	Bias voltage falling	50		92	%V <sub>BIAS</sub>
V <sub>UVLHI</sub>	V <sub>BIAS_LHI</sub> undervoltage threshold	V <sub>BIAS_LHI</sub> voltage increasing		8		V
		V <sub>BIAS_LHI</sub> voltage falling		6.5		V
R <sub>DS</sub>	Boost switch R <sub>DS(on)</sub>	T <sub>J</sub> = 25°C		2		Ω
V <sub>RIP</sub>	Output ripple voltage <sup>(1)</sup>				200	mVpk-pk
F <sub>SW</sub>	Switching frequency		1.35	1.5	1.65	MHz
V <sub>OSB</sub>	Voltage overshoot at start up				2	%V <sub>BIAS</sub>
t <sub>ss</sub>	Power up	C <sub>OUT</sub> = 3.3 μF, Measured between 10 to 90% of target V <sub>BIAS</sub>			1	ms
t <sub>dis</sub>	Discharge current sink		400			mA

(1) Output ripple voltage relies on suitable external components being selected and good printed circuit board layout practice.

## ELECTRICAL CHARACTERISTICS

### Reset Voltage Buck-Boost Converter

T<sub>A</sub> = 25°C, P12V = 10.8 V to 13.2 V (unless otherwise noted)

PARAMETER		TEST CONDITIONS	MIN	TYP	MAX	UNIT
I <sub>RL</sub>	Output current: reset outputs	Load = 400 pF, 39 Ω, repetition frequency = 50 kHz	0		18	mA
I <sub>QL</sub>	Output current: quiescent / drivers	Load = 400 pF, 39 Ω, repetition frequency = 50 kHz			3	mA
I <sub>CLFR</sub>	Current limit flag	Corresponding current on output at P12V = 10.8 V	25			mA
I <sub>CLR</sub>	Current limit	Measured on input	400		800	mA
V <sub>RESET</sub>	Output voltage		-25.5	-26	-26.5	V
V <sub>UVR</sub>	Undervoltage threshold	Reset voltage falling	50		92	%V <sub>RESET</sub>
R <sub>DS</sub>	Buck-boost switch R <sub>DS(on)</sub>	T <sub>J</sub> = 25°C		8		Ω
V <sub>RIP</sub>	Output ripple voltage <sup>(1)</sup>				200	mVpk-pk
F <sub>SW</sub>	Switching frequency		1.35	1.5	1.65	MHz
V <sub>OSR</sub>	Voltage overshoot at start up				2	%V <sub>RESET</sub>
t <sub>ss</sub>	Power up	C <sub>OUT</sub> = 3.3 μF, Measured between 10 to 90% of target V <sub>RESET</sub>			1	ms
t <sub>dis</sub>	Discharge current sink		400			mA

(1) Output ripple voltage relies on suitable external components being selected and good printed circuit board layout practice.

**ELECTRICAL CHARACTERISTICS****V<sub>OFFSET</sub>/DMDVCC2 Regulator**T<sub>A</sub> = 25°C, P12V = 10.8 V to 13.2 V (unless otherwise noted)

PARAMETER		TEST CONDITIONS	MIN	TYP	MAX	UNIT
I <sub>RL</sub>	Output current: reset outputs	Load = 400 pF, 39 Ω, repetition frequency = 50 kHz	0		12.2	mA
I <sub>QL</sub>	Output current: quiescent / drivers	Load = 400 pF, 39 Ω, repetition frequency = 50 kHz			3	mA
I <sub>DL</sub>	Output current: DMDVCC2		0		30	mA
I <sub>CLO</sub>	Current limit		100			mA
V <sub>OFFSET</sub>	Output Voltage	DLP9500, DLP5500	8.25	8.5	8.75	V
		DLP7000	7.25	7.5	7.75	
V <sub>UVO</sub>	Undervoltage threshold	V <sub>OFFSET</sub> voltage falling	50		92	%V <sub>OFFSET</sub>
V <sub>RIP</sub>	Output ripple voltage <sup>(1)</sup>				100	mVpk-pk
V <sub>OSO</sub>	Voltage overshoot at start-up				2	%V <sub>OFFSET</sub>
t <sub>ss</sub>	Power up	C <sub>OUT</sub> = 4.7 μF, Measured between 10 to 90% of target V <sub>OFFSET</sub>			1	ms
t <sub>dis</sub>	Discharge time constant				100	μs

(1) Output ripple voltage relies on suitable external components being selected and good printed circuit board layout practice.

## SWITCHING CHARACTERISTICS

over operating free-air temperature range (unless otherwise noted)

PARAMETER		TEST CONDITIONS	MIN	TYP	MAX	UNIT
Serial Communication Port Interface						
A <sup>(1)</sup>	Setup $\overline{\text{SCPEN}}$ Low To SCPCK	Reference to rising edge of SCPCK	360			ns
B <sup>(1)</sup>	Byte To Byte Delay	Nominally 1 SCPCK cycle, rising edge to rising edge	1.9			$\mu\text{s}$
C <sup>(1)</sup>	Setup SCPDI To $\overline{\text{SCPEN}}$ High	Last byte to slave disable	360			ns
D <sup>(1)</sup>	SCPCK Frequency <sup>(2)</sup>		0		526	kHz
	SCPCK Period		1.9	2		$\mu\text{s}$
E <sup>(1)</sup>	SCPCK High Or Low Time		300			ns
F <sup>(1)</sup>	SCPDI Set-Up Time	Reference to falling edge of SCPCK	300			ns
G <sup>(1)</sup>	SCPDI Hold Time	Reference from falling edge of SCPCK	300			ns
H <sup>(1)</sup>	SCPDO Propagation Delay	Reference from rising edge of SCPCK			300	ns
	$\overline{\text{SCPEN}}$ , SCPCK, SCPDI, $\overline{\text{RESET}}$ Filter (Pulse Reject)		150			ns
Output Micromirror Clocking Pulses						
F <sub>PREP</sub>	Phased reset repetition frequency each output pin (non-overlapping)				50	kHz
F <sub>GREP</sub>	Global reset repetition frequency all output pins				50	kHz
I <sub>RLK</sub>	V <sub>RESET</sub> output leakage current	$\overline{\text{OE}} = 1$ , V <sub>RESET_RAIL</sub> = -28.5V		-1	-10	$\mu\text{A}$
I <sub>BLK</sub>	V <sub>BIAS</sub> output leakage current	$\overline{\text{OE}} = 1$ , V <sub>BIAS_RAIL</sub> = 28.5V		1	10	$\mu\text{A}$
I <sub>OLK</sub>	V <sub>OFFSET</sub> output leakage current	$\overline{\text{OE}} = 1$ , V <sub>OFFSET_RAIL</sub> = 10.25V		1	10	$\mu\text{A}$
Output Micromirror Clocking Pulse Controls						
t <sub>SPW</sub>	STROBE Pulsewidth		10			ns
t <sub>SP</sub>	STROBE Period		20			ns
t <sub>OHZ</sub>	Output Time To High Impedance	$\overline{\text{OE}}$ Pin = High			100	ns
t <sub>OEN</sub>	Output Enable Time From High Impedance	$\overline{\text{OE}}$ Pin = Low			100	ns
t <sub>SUS</sub>	Set-Up Time	From A[3:0], MODE[1:0], and SEL[1:0] to STROBE edge	8			ns
t <sub>HOS</sub>	Hold time	From A[3:0], MODE[1:0], and SEL[1:0] to STROBE edge	8			ns
t <sub>PBR</sub>	Propagation time	From STROBE to V <sub>BIAS</sub> /V <sub>RESET</sub> edge 50% point.	80		200	ns
t <sub>PRO</sub>		From STROBE to V <sub>RESET</sub> /V <sub>OFFSET</sub> edge 50% point.	80		200	ns
t <sub>POB</sub>		From STROBE to V <sub>OFFSET</sub> /V <sub>BIAS</sub> edge 50% point.	80		200	ns
t <sub>DEL</sub>	Edge-to-edge propagation delta	Maximum difference between the slowest and fastest propagation times for any given reset output.			40	ns
t <sub>CHCH</sub>	Output channel-to-channel propagation delta	Maximum difference between the slowest and fastest propagation times for any two outputs for any given edge.			20	ns

 (1) See [Figure 2](#)

(2) There is no minimum speed for the serial port. It can be written to statically for diagnostic purposes.

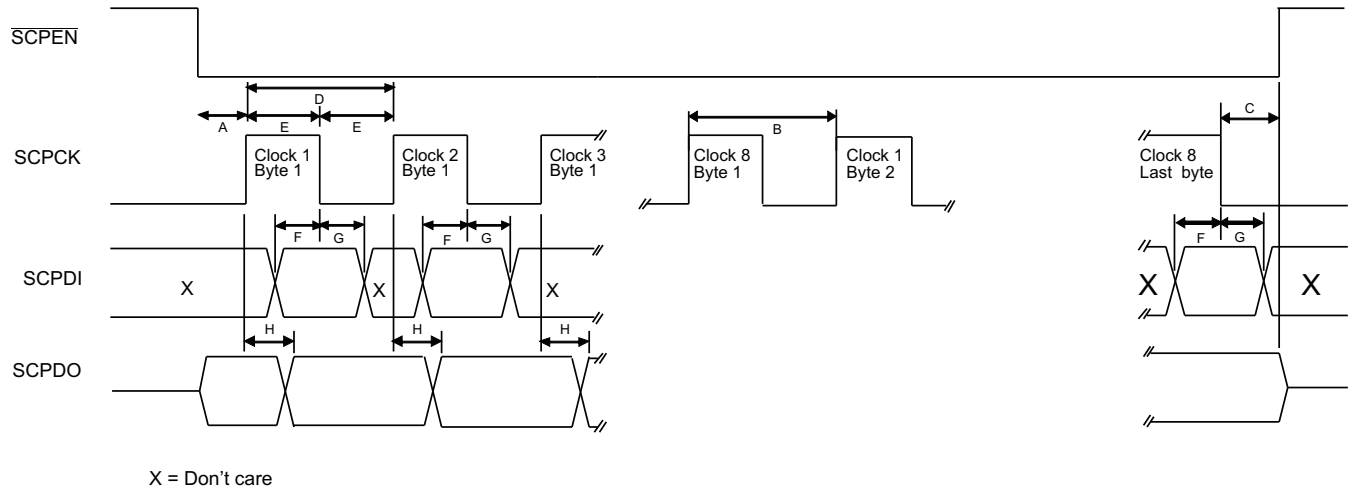

**Figure 2. Serial Interface Timing**

## PRINCIPLES OF OPERATION

### 5-V Linear Regulator

The 5-V linear regulator supplies the 5 V requirement of the DLPA200 internal logic.

Figure 3 shows the block diagram of this module. The input de-coupling capacitors are shared with other internal DLPA200 modules. See [Component Selection Guidelines](#) for recommended component values.

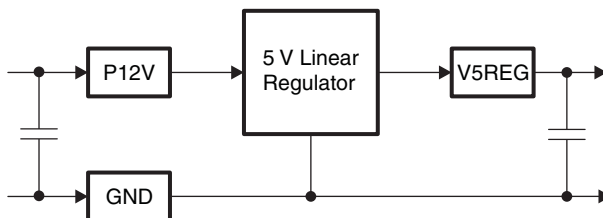

Figure 3. 5-Volt Linear Regulator Block Diagram

### Bias Voltage Boost Converter

The bias voltage converter is a switching supply that operates at 1.5 MHz. The bias switching device switches 180° out-of-phase with the reset switching device.

The converter supplies the internal bias voltage for the high voltage FET switches and the external  $V_{BIAS}$  for the DMD border mirrors. The  $V_{BIAS}$  voltage level can be different for different generations of DMDs. The  $V_{BIAS}$  voltage level is configured by the DLP Controller chip over a serial communication interface. Four control bits select the voltage level while a fifth bit is the on/off control. The module provides two status bits to indicate latched and unlatched status bits for under-voltage ( $V_{UV}$ ) and current-limit ( $C_L$ ) conditions.

Figure 4 shows the block diagram of this module. The input de-coupling capacitors are shared with other internal DLPA200 modules. See [Component Selection Guidelines](#) for recommended component values.

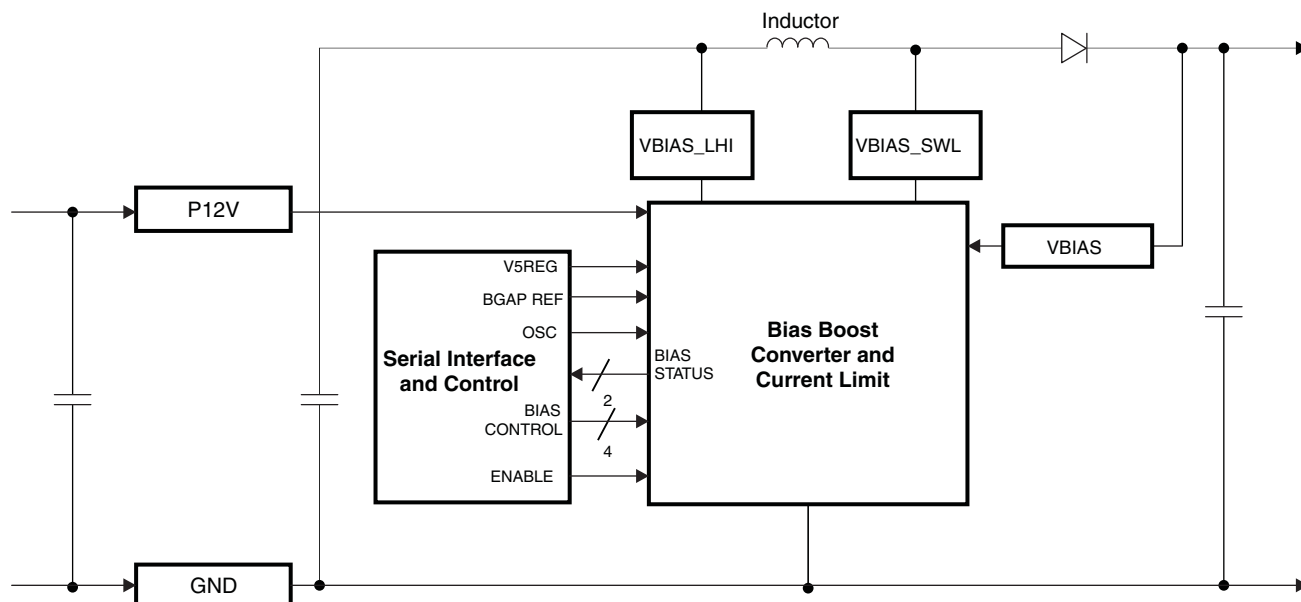

Figure 4. Bias Voltage Boost Converter Block Diagram

### Reset Voltage Buck-Boost Converter

The reset voltage buck-boost converter is a switching supply that operates at 1.5 MHz. The reset switching device switches 180° out-of-phase with the bias switching device.

The converter supplies the internal reset voltage levels for the high voltage FET switches. The  $V_{\text{RESET}}$  voltage level can be different for different generations of DMDs. The  $V_{\text{RESET}}$  voltage level is configured by the DLP Controller chip over a serial communication interface. Four control bits select the voltage level while a fifth bit is the on/off control. The module provides two status bits to indicate latched and unlatched status bits for under-voltage ( $V_{\text{UV}}$ ) and current-limit ( $C_L$ ) conditions.

Figure 5 shows the block diagram of this module. The input de-coupling capacitors are shared with other internal DLPA200 modules. See [Component Selection Guidelines](#) for recommended component values.

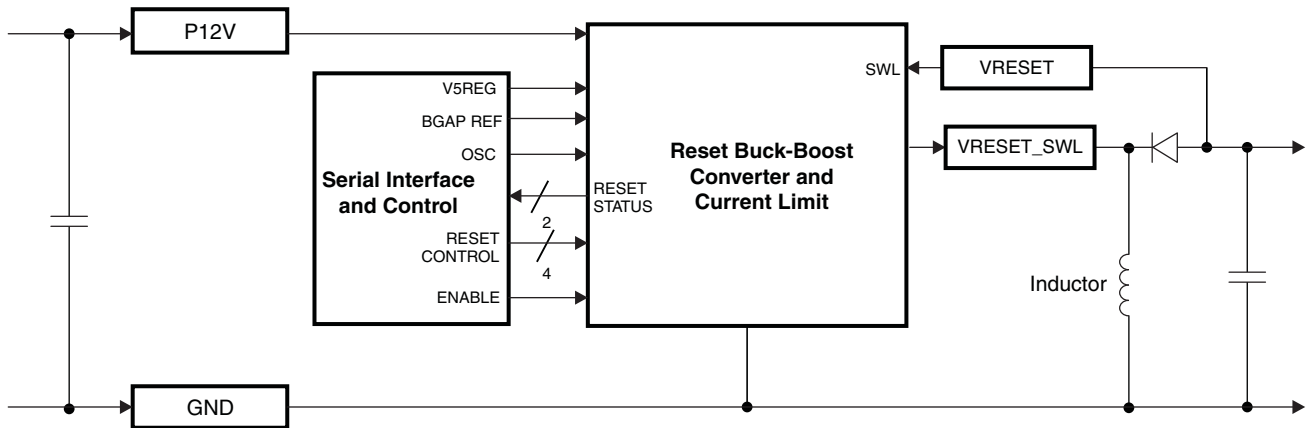

Figure 5. Reset Voltage Buck-Boost Converter Block Diagram

### $V_{\text{OFFSET}}$ /DMDVCC2 Regulator

The  $V_{\text{OFFSET}}$ /DMDVCC2 regulator supplies the internal  $V_{\text{OFFSET}}$  voltage for the high voltage FET switches and the external DMDVCC2 for the DMD. The  $V_{\text{OFFSET}}$  voltage level can be different for different generations of DMDs. The  $V_{\text{OFFSET}}$  voltage level is configured by the DLP Controller chip over a serial communication interface. Four control bits select the voltage level while a fifth bit is the on/off control. The module provides 2 status bits to indicate latched and unlatched status bits for under-voltage ( $V_{\text{UV}}$ ) and current-limit ( $C_L$ ) conditions.

Figure 6 shows the block diagram of this module. The input de-coupling capacitors are shared with other DLPA200 modules. See [Component Selection Guidelines](#) for recommended component values.

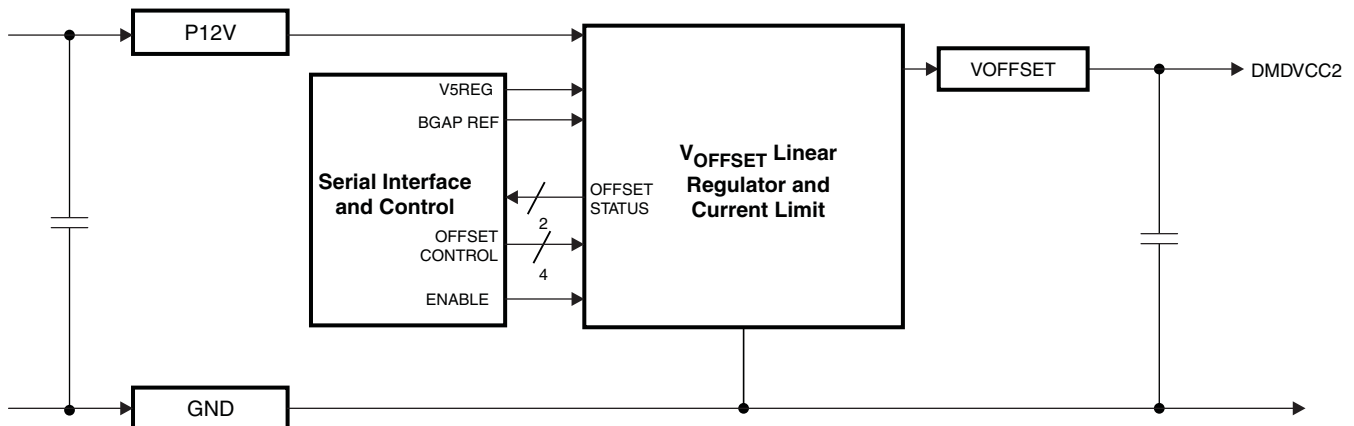

Figure 6. Offset Voltage Boost Converter Block Diagram

### Serial Communications Port (SCP)

The Serial Communications Port (SCP) is a full duplex, synchronous, character-oriented (byte) port that allows exchange of data between the master ASIC or FPGA, and one or more slave DLPA200s (and/or other DLPTM devices).

**Table 4. Serial Communications Port Signal Definitions**

SIGNAL	I/O	FROM/TO	TYPE	DESCRIPTION
SCPCK	I	SCP bus master to slave	LVTTTL compatible	SCP bus serial transfer clock. The host processor (master) generates this clock.
$\overline{\text{SCPEN}}$	I	SCP bus master to slave	LVTTTL compatible	SCP bus access enable (low true). When high, slave will reset to idle state, and SCPDO output will tri-state. Pulling $\overline{\text{SCPEN}}$ low initiates a read or write access. $\overline{\text{SCPEN}}$ must remain low for an entire read/write access, and must be pulled high after the last data cycle. To abort a read or write cycle, pull $\overline{\text{SCPEN}}$ high at any point.
SCPDI	I	SCP bus master to slave	LVTTTL compatible	SCP bus serial data input. Data bits are valid and must be clocked in on the falling edge of SCPCK.
SCPDO	O	SCP bus slave to master	LVTTTL, open drain w/tri-state	SCP bus serial data output. Data bits must clocked out on the rising edge of SCPCK. A 1k pull up resistor to the 3.3 volt ASIC supply is required.
$\overline{\text{IRQ}}$	O	SCP bus slave to master	LVTTTL, open drain	Not part of the SCP bus definition. Asynchronous interrupt signal from slave to request service from master. A 1k pull up resistor to the 3.3 volt ASIC supply is required.

## PWB LAYOUT AND ROUTING GUIDELINES

### CAUTION

Board layout and routing guidelines must be followed explicitly and all external components used must be in the range of values and of the quality recommended for proper operation of the DLPA200. Important: Thermal pad(s) must be tied to VRESET\_RAIL, do not connect to ground.

### CAUTION

Thermal pad(s) must be tied to VRESET\_RAIL, do not connect to ground.

## General Guidelines

Suitable Kelvin connections should be provided for the switching regulator feedback pins:  $V_{\text{BIAS}}$  (pin 9) and  $V_{\text{RESET}}$  (pin 13).

The etch traces that connect the switching devices:  $V_{\text{BIAS\_SWL}}$  (pin 8) and  $V_{\text{RESET\_SWL}}$  (pin 12) should be as short and wide as possible to minimize leakage inductances. The etch traces that connect the switching converter components (inductors, flywheel diodes and filtering capacitors) should also be as short and wide as possible. The electrical loops that these components form should be as small and compact as possible, with the ground referenced components forming a star connection.

Due to the fast switching transitions appearing on the sixteen reset OUTx pins, it is recommended to keep these traces as short as possible. Also, to minimize potential cross-talk between outputs, it is advisable to maintain as much clearance between each of the output traces.

## Grounding Guidelines

The PWB should have an internal ground plane that extends under the DLPA200. All 9 ground pins (1, 7, 14, 20, 41, 46, 53, 55, and 60) must be connected to the ground plane using the shortest possible runs and vias. All filter and bypass capacitors must be placed near the pin being filtered or bypassed for the shortest possible runs to the part and to the ground plane.

## Thermal Guidelines

The DLPA200 package should be thermally bonded or soldered to an external thermal pad on the PWB surface. The recommended dimensions of the thermal pad are 10 x 10 mm centered under the part. The metal bottom of the package is tied internally to the substrate at the VRESET\_RAIL voltage level. Therefore, the thermal pad on the board must be isolated from any other extraneous circuit or ground and no circuit vias are allowed inside the pad area. Thermal pads are required on both sides of the PWB and should be connected together through an array of 5 x 5 thermal vias, 0.5 mm in diameter. **Thermal pads and the thermal vias are connected to VRESET\_RAIL and isolated from ground, or any other circuit.** An internal P12V or VBB plane should be located directly underneath the top layer and have an isolated area under the DLPA200. This isolated area must be a minimum of 20 cm<sup>2</sup> and connect to the thermal pad of the DLPA200 through the thermal vias. The potential of the isolated area will also be at VRESET\_RAIL. The internal ground plane should extend under the DLPA200 to help carry the heat away. Please refer to the PowerPAD Thermally Enhanced Package application report (TI literature number [SLMA002](#)) for details on thermally efficient package design considerations.

Careful consideration should be taken with respect to DLPA200 placement in the vicinity of local PWB hotspots. Heat generated from adjacent components may impact the DLPA200 thermal characteristics.

## Power Supply Rail Guidelines

[Table 5](#) through [Table 9](#) provides discrete component selection guidelines.

The P12V filter and bypass capacitors should be distributed and connected to pin 11 and pins 48 & 50. These capacitors should be placed as near to their respective pins as possible and if necessary, should be placed on the bottom layer.

The V5REG filter and bypass capacitors must be placed near and connected to pin 47.

The VBIAS\_RAIL etch runs should be routed in the following order: pin 40, pin 31, pin 30, pin 21, pin 80, pin 71, pin 70, and pin 61. The etch runs should be short and direct as they must carry 35 ns current spikes of up to 0.64 amps peak. Bypass capacitors should be located near and connected to pins 30 and 71 to provide bypassing on both sides.

The VBIAS\_LHI filter and bypass capacitors must be placed near and connected to pin 10.

The VBIAS filter and bypass capacitors must be placed near and connected to pin 9. VBIAS pin 9 must also be connected (optionally with a 0-ohm resistor) to VBIAS\_RAIL at or between pins 21 and 80.

The VRESET\_RAIL etch runs should be routed in the following order: pin 36, pin 35, pin 26, pin 25, pin 76, pin 75, pin 66, and pin 65. The etch runs should be short and direct as they must carry 35 ns current spikes of up to 0.64 amps peak. Bypass capacitors should be placed near and connected to pins 35 and 66 to provide bypassing on both sides.

The VRESET filter and bypass capacitors must be located near and connected to pin 13. VRESET pin 13 must also be connected (optionally with a 0-ohm resistor) to VRESET\_RAIL at or between pins 25 and 76.

The VOFFSET\_RAIL etch runs should be routed in the following order: pin 23, pin 28, pin 33, pin 38, pin 63, pin 68, pin 73, and pin 78. The etch runs should be short and direct as they must carry 35 ns current spikes of up to 0.64 amps peak. Bypass capacitors should be placed near and connected to pins 28 and 73 to provide bypassing on both sides.

The VOFFSET filter and bypass capacitors must be placed near and connected to pin 49. VOFFSET pin 49 must also be connected (optionally with a 0-ohm resistor) to VOFFSET\_RAIL at or between pins 38 and 63.

---

### NOTE

Aluminum electrolytic capacitors may not be suitable for the DLPA200 application. At the switching frequencies used in the DLPA200 (up to 1.5MHz), aluminum electrolytic capacitors drop significantly in capacitance and increase in ESR resulting in voltage spikes on the power supply rails, which could cause the device to shut down or perform in an unreliable manner.

---

## COMPONENT SELECTION GUIDELINES

**Table 5. 5-V Regulator**

COMPONENT	VALUE	TYPE OR PART NUMBER	CONNECTION 1	CONNECTION 2
P12V filter capacitor	10 to 33 $\mu$ F, 20 VDC, 1 $\Omega$ max ESR	Tantalum or ceramic	Pos: P12V, pin 11 (locate near pin 11)	Neg: Ground
P12V bypass capacitor	0.1 $\mu$ F, 50 VDC, 0.1 $\Omega$ max ESR	Ceramic	P12V, pin 11 (locate near pin 11)	Ground
V5REG filter capacitor	0.1 <sup>(1)</sup> to 1.0 $\mu$ F, 10 VDC, 2.5 $\Omega$ max ESR	Tantalum or ceramic	Pos: V5REG, pin 47 (locate near pin 47)	Neg: Ground
V5REG bypass capacitor	0.1 $\mu$ F <sup>(1)</sup> , 16 VDC, 0.1 $\Omega$ max ESR	Ceramic	V5REG, pin 47 (locate near pin 47)	Ground

(1) To ensure stability of the linear regulator, the capacitance should not be less than 0.1  $\mu$ F.

**Table 6. Bias Voltage Boost Converter**

COMPONENT	VALUE	TYPE OR PART NUMBER	CONNECTION 1	CONNECTION 2
LHI filter capacitor	10 $\mu$ F, 20 VDC, 1 $\Omega$ max ESR	Tantalum or ceramic	Pos: VBIAS_LHI, pin 10 (locate near pin 10)	Neg: Ground
LHI bypass capacitor	0.1 $\mu$ F, 50 VDC, 0.1 $\Omega$ max ESR	Ceramic	VBIAS_LHI, pin 10 (locate near pin 10)	Ground
VBIAS filter capacitor	1 to 10 $\mu$ F, 35 VDC, 1 $\Omega$ max ESR; (3.3 $\mu$ F nominal value)	Tantalum or ceramic	Pos: VBIAS, pin 9 (locate near pin 9)	Neg: Ground
VBIAS bypass capacitor	0.1 $\mu$ F, 50 VDC, 0.1 $\Omega$ max ESR	Ceramic	VBIAS, pin 9 (locate near pin 9)	Ground
VBIAS_RAIL bypass capacitors (2 required)	0.1 $\mu$ F, 50 VDC, 0.1 $\Omega$ max ESR	Ceramic	VBIAS_RAIL, pins 30 and 71 (locate near pins 30 and 71)	Ground
Resistor jumper (optional)	0- $\Omega$ normally (1 $\Omega$ for testing <sup>(1)</sup> )		VBIAS, pin 9	VBIAS_RAIL, pins 21 or 80
Inductor	22 $\mu$ H, 0.5 amp, 160 m $\Omega$ ESR	Coil Craft DT1608C-223 (or equivalent)	VBIAS_LHI, pin 10	VBIAS_SWL, pin 8
Schottky diode	0.5A, 40V (minimum)	Motorola MBR0540T1 or STMicroelectronics STPS0540Z, STPS0560Z (or equivalent)	Anode: VBIAS_SWL, pin 8	Cathode: VBIAS, pin 9

(1) Allows for VBIAS current measurement.

**Table 7. Reset Voltage Boost Converter**

COMPONENT	VALUE	TYPE OR PART NUMBER	CONNECTION 1	CONNECTION 2
VRESET filter capacitor	1 to 10 $\mu$ F, 35 VDC, 1 $\Omega$ max ESR; (3.3 $\mu$ F nominal value)	Tantalum or ceramic	Neg: VRESET, pin 13 (locate near pin 13)	Pos: Ground
VRESET bypass capacitor	0.1 $\mu$ F, 50 VDC, 0.1 $\Omega$ max ESR	Ceramic	VRESET, pin 13 (locate near pin 13)	Ground
VRESET_RAIL bypass capacitors (2 required)	0.1 $\mu$ F, 50 VDC, 0.1 $\Omega$ max ESR	Ceramic	VRESET_RAIL, pins 35 and 66 (locate near pins 35 and 66)	Ground
Resistor jumper (optional)	0- $\Omega$ normally (1 $\Omega$ for testing <sup>(1)</sup> )		VRESET, pin 13	VRESET_RAIL, pins 25 or 76
Inductor	22 $\mu$ H, 0.5A, 160 m $\Omega$	Coil Craft DT1608C-223 (or equivalent)	VRESET_SWL, pin 12	Ground

(1) Allows for VRESET current measurement.

**Table 7. Reset Voltage Boost Converter (continued)**

COMPONENT	VALUE	TYPE OR PART NUMBER	CONNECTION 1	CONNECTION 2
Schottky diode	0.5 A (minimum), 60 V	STMicroelectronics STPS0560Z or International Rectifier 10MQ060N (or equivalent)	Cathode: VRESET_SWL, pin 12	Anode: VRESET, pin 13

**Table 8. Offset Voltage Regulator**

COMPONENT	VALUE	TYPE OR PART NUMBER	CONNECTION 1	CONNECTION 2
VOFFSET/VCC2 filter capacitors (2 required)	1 <sup>(1)</sup> to 4.7 <sup>(2)</sup> $\mu$ F, 35 VDC, 1 $\Omega$ max ESR	Tantalum or ceramic	Pos: VOFFSET, pin 49 (1st near pin 49) Pos: DMDVCC2 pins (locate 2nd at DMD)	Neg: Ground at DLPA200 Neg: Ground at DMD
VOFFSET/VCC2 bypass capacitors (5 required)	0.1 $\mu$ F, 50 VDC, 0.1 $\Omega$ max ESR	Ceramic	VOFFSET, pin 49 (locate 1 near pin 49) DMD DMDVCC2 pins (locate 4 near DMD pins)	Ground at DLPA200 Ground at DMD
VOFFSET_RAIL bypass capacitor (2 required)	0.1 $\mu$ F, 50 VDC, 0.1 $\Omega$ max ESR	Ceramic	VOFFSET_RAIL, pins 28 and 73 (locate near pins 28 and 73)	Ground
Resistor jumper (optional)	0- $\Omega$ normal (1 $\Omega$ for testing <sup>(3)</sup> )		VOFFSET, pin 49	VOFFSET_RAIL, pins 38 or 63
Resistor jumper (optional)	0-ohm normal (1 $\Omega$ for testing <sup>(4)</sup> )		VOFFSET, pin 49	DMDVCC2 pins

- (1) To ensure stability of the linear regulator, the absolute minimum output capacitance should not be less than 1.0  $\mu$ F.  
(2) Recommended value is 3.3  $\mu$ F each. Different values are acceptable, provided that the sum of the two is 6.8  $\mu$ F maximum.  
(3) Allows for V<sub>OFFSET</sub> current measurement  
(4) Allows for DMDVCC2 current measurement

**Table 9. Pullup Resistors**

COMPONENT	VALUE	TYPE OR PART NUMBER	CONNECTION 1	CONNECTION 2
Resistor	1 k $\Omega$		SCPDO, pin 42	Chipset controller 3.3-V V <sub>DD</sub>
Resistor	1 k $\Omega$		$\overline{\text{IRQ}}$ , pin 43	Chipset Controller 3.3-V V <sub>DD</sub>
Resistor (optional)	1 k $\Omega$		$\overline{\text{OE}}$ , pin 6	Chipset Controller 3.3-V V <sub>DD</sub>

## REVISION HISTORY

---

### Changes from Original (April 2010) to Revision A Page

- Changed device marking to include TI internal part number ..... 5
- 

### Changes from Revision A (June 2010) to Revision B Page

- Added APPLICATIONS ..... 1
  - Changed the DESCRIPTION, added [Table 1](#) ..... 1
  - Added *Device Configurations* table ..... 3
  - Changed I/O type of the signals ..... 6
  - Corrected VRESET\_SWL, VBIAS\_RAIL and VOFFSET\_RAIL signal notations ..... 7
  - Added  $V_{BIAS}$  voltage to ELECTRICAL CHARACTERISTICS ..... 9
  - Added  $V_{RESET}$  voltage values to Reset Voltage Buck-Boost Converter ..... 9
  - Added  $V_{OFFSET}$  voltage to ELECTRICAL CHARACTERISTICS ..... 10
  - Added subsection *Serial Communications Port (SCP)* ..... 14
  - Deleted Driver Output Logic Block section ..... 14
  - Added *Serial Communications Port Signal Definitions* table ..... 15
  - Changed Warning to Caution ..... 15
  - Changed Warning to Note ..... 16
- 

### Changes from Revision B (August 2012) to Revision C Page

- Added DLPR4101 to DLPR410 throughout document ..... 2
  - Changed text From: DLPA200PFC is functionally. equivalent.. To: DLPA200PFP ..... 5
  - Changed DAD2000 to DLPA200 in the Serial Communications Port (SCP) section ..... 14
-

**PACKAGING INFORMATION**

Orderable Device	Status (1)	Package Type	Package Drawing	Pins	Package Qty	Eco Plan (2)	Lead/Ball Finish (6)	MSL Peak Temp (3)	Op Temp (°C)	Device Marking (4/5)	Samples
DLPA200PFP	ACTIVE	HTQFP	PFP	80	5	Pb-Free (RoHS)	CU NIPDAU	Level-2-260C-1 YEAR			<b>Samples</b>

(1) The marketing status values are defined as follows:

**ACTIVE:** Product device recommended for new designs.

**LIFEBUY:** TI has announced that the device will be discontinued, and a lifetime-buy period is in effect.

**NRND:** Not recommended for new designs. Device is in production to support existing customers, but TI does not recommend using this part in a new design.

**PREVIEW:** Device has been announced but is not in production. Samples may or may not be available.

**OBSOLETE:** TI has discontinued the production of the device.

(2) Eco Plan - The planned eco-friendly classification: Pb-Free (RoHS), Pb-Free (RoHS Exempt), or Green (RoHS & no Sb/Br) - please check <http://www.ti.com/productcontent> for the latest availability information and additional product content details.

**TBD:** The Pb-Free/Green conversion plan has not been defined.

**Pb-Free (RoHS):** TI's terms "Lead-Free" or "Pb-Free" mean semiconductor products that are compatible with the current RoHS requirements for all 6 substances, including the requirement that lead not exceed 0.1% by weight in homogeneous materials. Where designed to be soldered at high temperatures, TI Pb-Free products are suitable for use in specified lead-free processes.

**Pb-Free (RoHS Exempt):** This component has a RoHS exemption for either 1) lead-based flip-chip solder bumps used between the die and package, or 2) lead-based die adhesive used between the die and leadframe. The component is otherwise considered Pb-Free (RoHS compatible) as defined above.

**Green (RoHS & no Sb/Br):** TI defines "Green" to mean Pb-Free (RoHS compatible), and free of Bromine (Br) and Antimony (Sb) based flame retardants (Br or Sb do not exceed 0.1% by weight in homogeneous material)

(3) MSL, Peak Temp. - The Moisture Sensitivity Level rating according to the JEDEC industry standard classifications, and peak solder temperature.

(4) There may be additional marking, which relates to the logo, the lot trace code information, or the environmental category on the device.

(5) Multiple Device Markings will be inside parentheses. Only one Device Marking contained in parentheses and separated by a "~" will appear on a device. If a line is indented then it is a continuation of the previous line and the two combined represent the entire Device Marking for that device.

(6) Lead/Ball Finish - Orderable Devices may have multiple material finish options. Finish options are separated by a vertical ruled line. Lead/Ball Finish values may wrap to two lines if the finish value exceeds the maximum column width.

**Important Information and Disclaimer:** The information provided on this page represents TI's knowledge and belief as of the date that it is provided. TI bases its knowledge and belief on information provided by third parties, and makes no representation or warranty as to the accuracy of such information. Efforts are underway to better integrate information from third parties. TI has taken and continues to take reasonable steps to provide representative and accurate information but may not have conducted destructive testing or chemical analysis on incoming materials and chemicals. TI and TI suppliers consider certain information to be proprietary, and thus CAS numbers and other limited information may not be available for release.

In no event shall TI's liability arising out of such information exceed the total purchase price of the TI part(s) at issue in this document sold by TI to Customer on an annual basis.



# MECHANICAL DATA

PFP (S-PQFP-G80)

PowerPAD™ PLASTIC QUAD FLATPACK

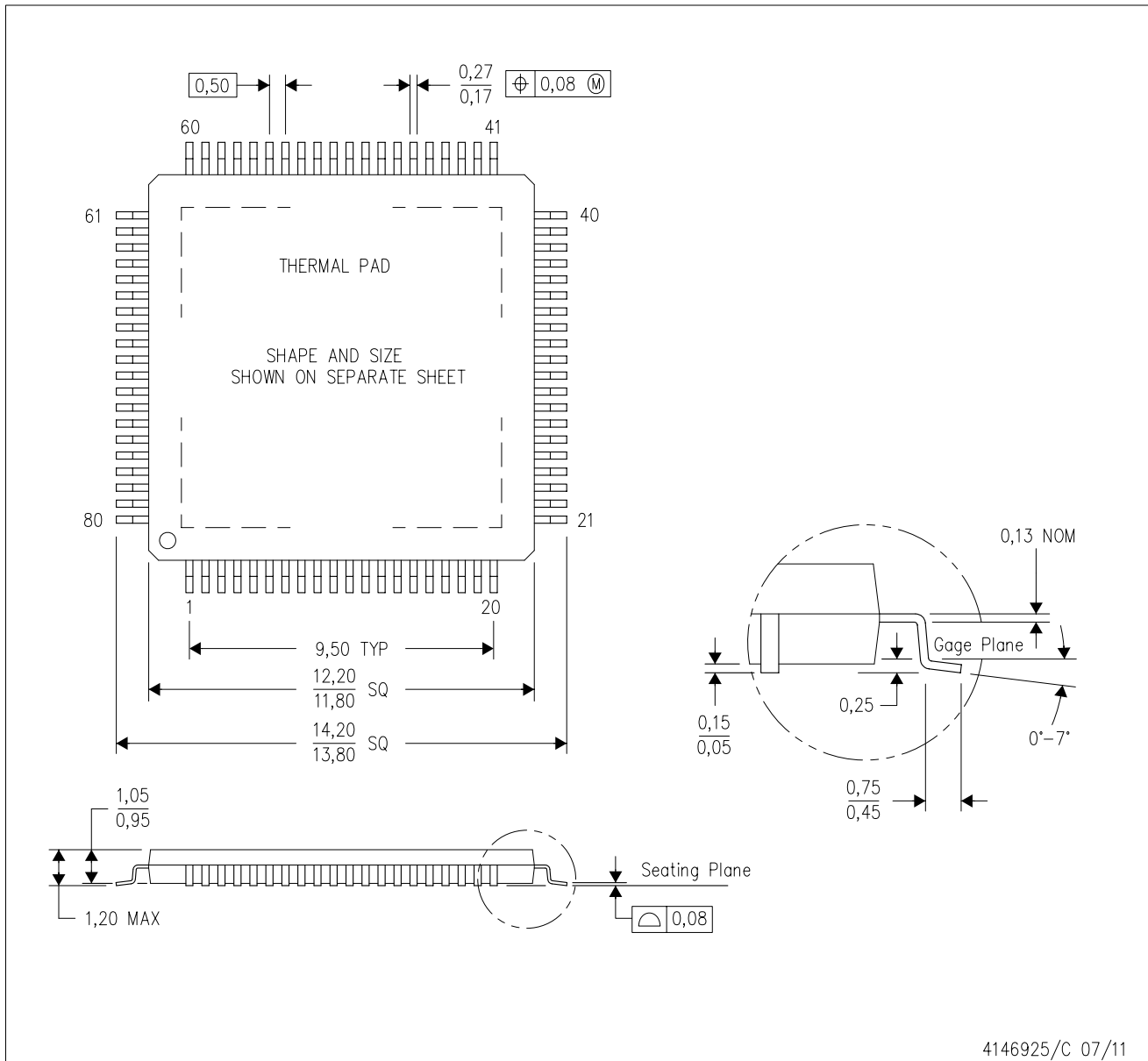

4146925/C 07/11

- NOTES:
- A. All linear dimensions are in millimeters.
  - B. This drawing is subject to change without notice.
  - C. Body dimensions do not include mold flash or protrusion
  - D. This package is designed to be soldered to a thermal pad on the board. Refer to Technical Brief, PowerPad Thermally Enhanced Package, Texas Instruments Literature No. SLMA002 for information regarding recommended board layout. This document is available at [www.ti.com](http://www.ti.com) <<http://www.ti.com>>.
  - E. See the additional figure in the Product Data Sheet for details regarding the exposed thermal pad features and dimensions.
  - F. Falls within JEDEC MS-026

PowerPAD is a trademark of Texas Instruments.

## THERMAL PAD MECHANICAL DATA

PFP (S-PQFP-G80)

PowerPAD™ PLASTIC QUAD FLATPACK

### THERMAL INFORMATION

This PowerPAD™ package incorporates an exposed thermal pad that is designed to be attached to a printed circuit board (PCB). The thermal pad must be soldered directly to the PCB. After soldering, the PCB can be used as a heatsink. In addition, through the use of thermal vias, the thermal pad can be attached directly to the appropriate copper plane shown in the electrical schematic for the device, or alternatively, can be attached to a special heatsink structure designed into the PCB. This design optimizes the heat transfer from the integrated circuit (IC).

For additional information on the PowerPAD package and how to take advantage of its heat dissipating abilities, refer to Technical Brief, PowerPAD Thermally Enhanced Package, Texas Instruments Literature No. SLMA002 and Application Brief, PowerPAD Made Easy, Texas Instruments Literature No. SLMA004. Both documents are available at [www.ti.com](http://www.ti.com).

The exposed thermal pad dimensions for this package are shown in the following illustration.

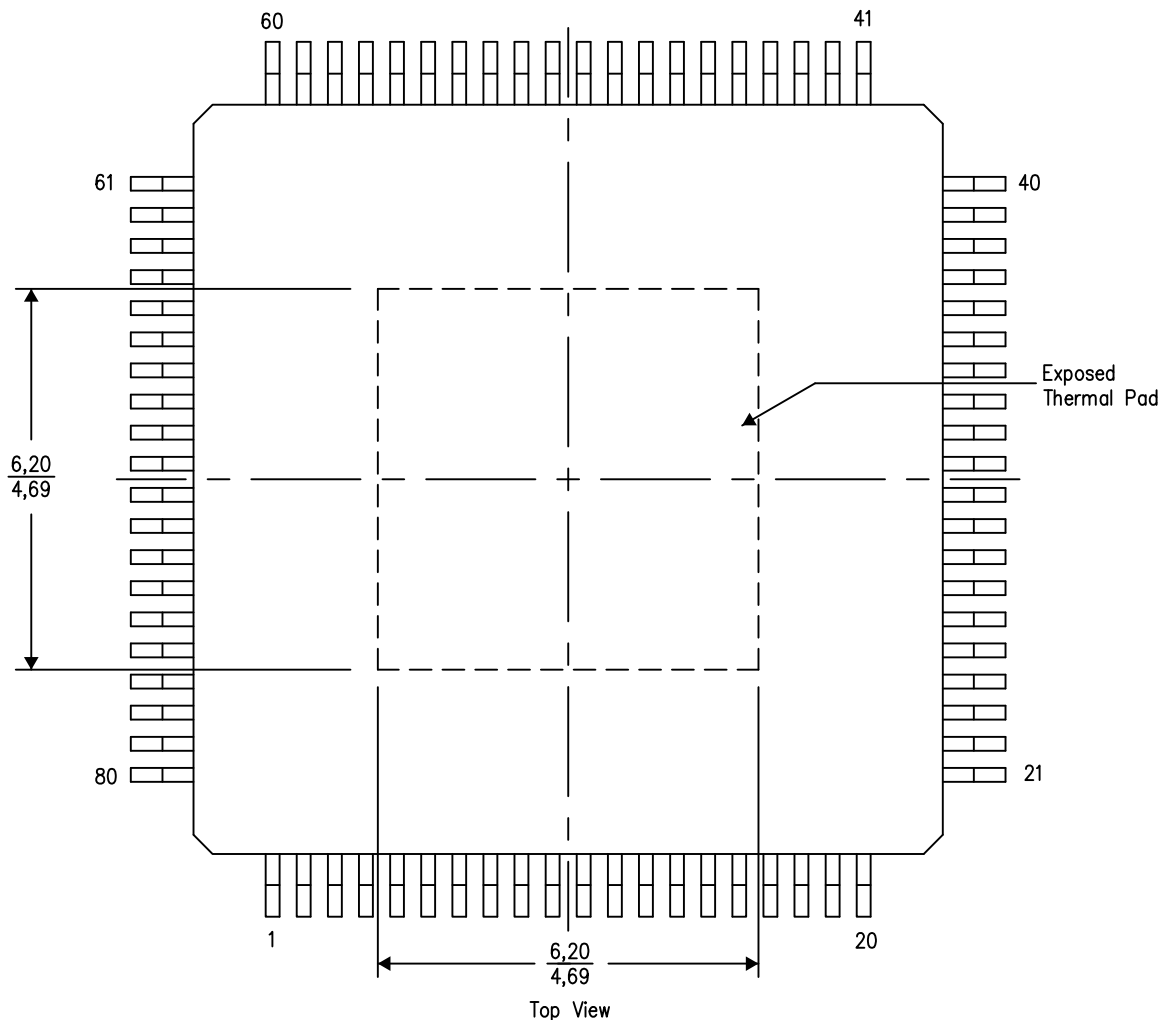

4206327-3/P 05/14

NOTE: A. All linear dimensions are in millimeters

PowerPAD is a trademark of Texas Instruments

PFP (S-PQFP-G80)

PowerPAD™ PLASTIC QUAD FLATPACK

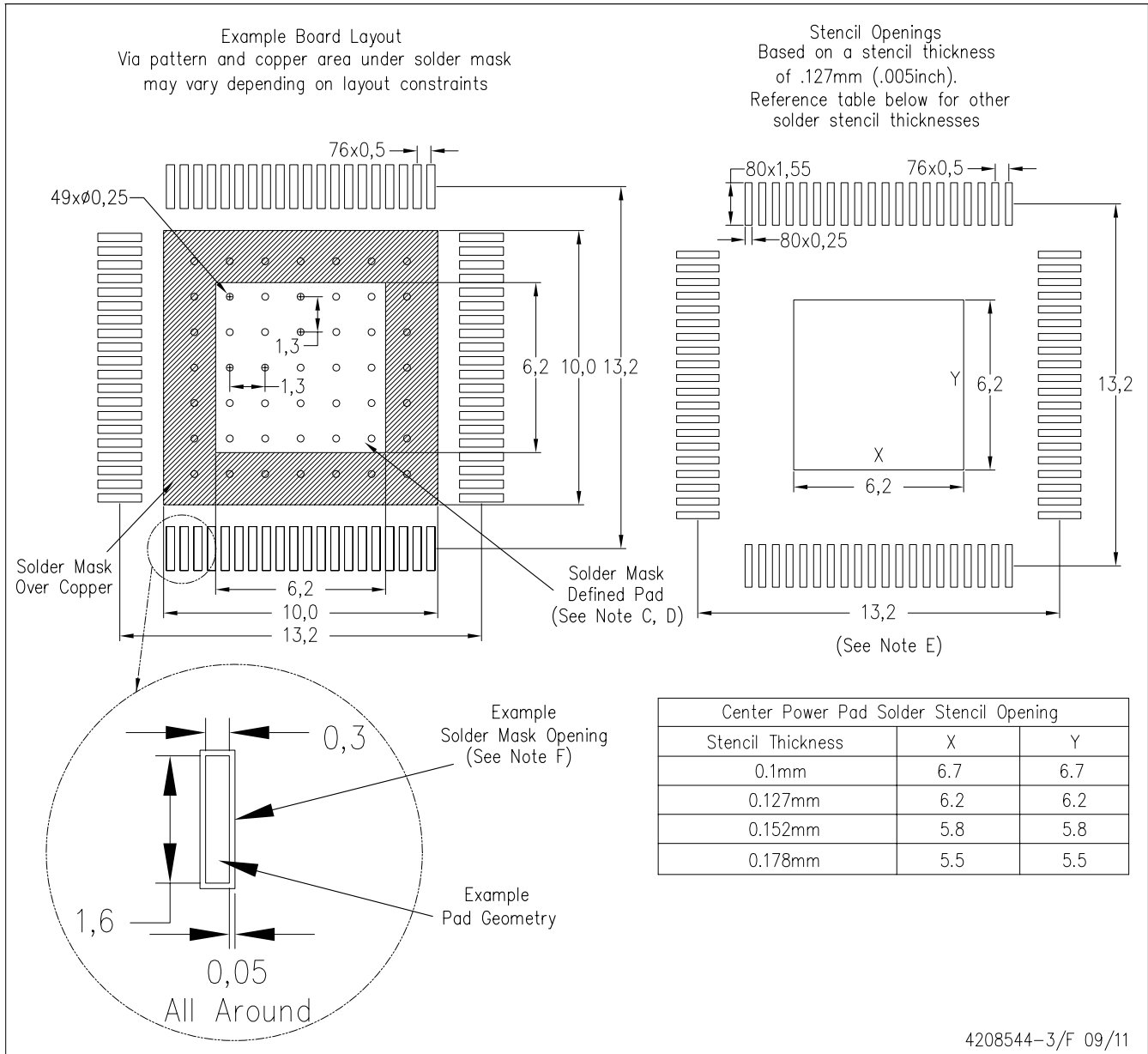

- NOTES:
- All linear dimensions are in millimeters.
  - This drawing is subject to change without notice.
  - Customers should place a note on the circuit board fabrication drawing not to alter the center solder mask defined pad.
  - This package is designed to be soldered to a thermal pad on the board. Refer to Technical Brief, PowerPAD Thermally Enhanced Package, Texas Instruments Literature No. SLMA002, SLMA004, and also the Product Data Sheets for specific thermal information, via requirements, and recommended board layout. These documents are available at [www.ti.com](http://www.ti.com) <<http://www.ti.com>>. Publication IPC-7351 is recommended for alternate designs.
  - Laser cutting apertures with trapezoidal walls and also rounding corners will offer better paste release. Customers should contact their board assembly site for stencil design recommendations. Example stencil design based on a 50% volumetric metal load solder paste. Refer to IPC-7525 for other stencil recommendations.
  - Customers should contact their board fabrication site for solder mask tolerances between and around signal pads.

PowerPAD is a trademark of Texas Instruments.

## IMPORTANT NOTICE

Texas Instruments Incorporated and its subsidiaries (TI) reserve the right to make corrections, enhancements, improvements and other changes to its semiconductor products and services per JESD46, latest issue, and to discontinue any product or service per JESD48, latest issue. Buyers should obtain the latest relevant information before placing orders and should verify that such information is current and complete. All semiconductor products (also referred to herein as "components") are sold subject to TI's terms and conditions of sale supplied at the time of order acknowledgment.

TI warrants performance of its components to the specifications applicable at the time of sale, in accordance with the warranty in TI's terms and conditions of sale of semiconductor products. Testing and other quality control techniques are used to the extent TI deems necessary to support this warranty. Except where mandated by applicable law, testing of all parameters of each component is not necessarily performed.

TI assumes no liability for applications assistance or the design of Buyers' products. Buyers are responsible for their products and applications using TI components. To minimize the risks associated with Buyers' products and applications, Buyers should provide adequate design and operating safeguards.

TI does not warrant or represent that any license, either express or implied, is granted under any patent right, copyright, mask work right, or other intellectual property right relating to any combination, machine, or process in which TI components or services are used. Information published by TI regarding third-party products or services does not constitute a license to use such products or services or a warranty or endorsement thereof. Use of such information may require a license from a third party under the patents or other intellectual property of the third party, or a license from TI under the patents or other intellectual property of TI.

Reproduction of significant portions of TI information in TI data books or data sheets is permissible only if reproduction is without alteration and is accompanied by all associated warranties, conditions, limitations, and notices. TI is not responsible or liable for such altered documentation. Information of third parties may be subject to additional restrictions.

Resale of TI components or services with statements different from or beyond the parameters stated by TI for that component or service voids all express and any implied warranties for the associated TI component or service and is an unfair and deceptive business practice. TI is not responsible or liable for any such statements.

Buyer acknowledges and agrees that it is solely responsible for compliance with all legal, regulatory and safety-related requirements concerning its products, and any use of TI components in its applications, notwithstanding any applications-related information or support that may be provided by TI. Buyer represents and agrees that it has all the necessary expertise to create and implement safeguards which anticipate dangerous consequences of failures, monitor failures and their consequences, lessen the likelihood of failures that might cause harm and take appropriate remedial actions. Buyer will fully indemnify TI and its representatives against any damages arising out of the use of any TI components in safety-critical applications.

In some cases, TI components may be promoted specifically to facilitate safety-related applications. With such components, TI's goal is to help enable customers to design and create their own end-product solutions that meet applicable functional safety standards and requirements. Nonetheless, such components are subject to these terms.

No TI components are authorized for use in FDA Class III (or similar life-critical medical equipment) unless authorized officers of the parties have executed a special agreement specifically governing such use.

Only those TI components which TI has specifically designated as military grade or "enhanced plastic" are designed and intended for use in military/aerospace applications or environments. Buyer acknowledges and agrees that any military or aerospace use of TI components which have **not** been so designated is solely at the Buyer's risk, and that Buyer is solely responsible for compliance with all legal and regulatory requirements in connection with such use.

TI has specifically designated certain components as meeting ISO/TS16949 requirements, mainly for automotive use. In any case of use of non-designated products, TI will not be responsible for any failure to meet ISO/TS16949.

### Products

Audio	<a href="http://www.ti.com/audio">www.ti.com/audio</a>
Amplifiers	<a href="http://amplifier.ti.com">amplifier.ti.com</a>
Data Converters	<a href="http://dataconverter.ti.com">dataconverter.ti.com</a>
DLP® Products	<a href="http://www.dlp.com">www.dlp.com</a>
DSP	<a href="http://dsp.ti.com">dsp.ti.com</a>
Clocks and Timers	<a href="http://www.ti.com/clocks">www.ti.com/clocks</a>
Interface	<a href="http://interface.ti.com">interface.ti.com</a>
Logic	<a href="http://logic.ti.com">logic.ti.com</a>
Power Mgmt	<a href="http://power.ti.com">power.ti.com</a>
Microcontrollers	<a href="http://microcontroller.ti.com">microcontroller.ti.com</a>
RFID	<a href="http://www.ti-rfid.com">www.ti-rfid.com</a>
OMAP Applications Processors	<a href="http://www.ti.com/omap">www.ti.com/omap</a>
Wireless Connectivity	<a href="http://www.ti.com/wirelessconnectivity">www.ti.com/wirelessconnectivity</a>

### Applications

Automotive and Transportation	<a href="http://www.ti.com/automotive">www.ti.com/automotive</a>
Communications and Telecom	<a href="http://www.ti.com/communications">www.ti.com/communications</a>
Computers and Peripherals	<a href="http://www.ti.com/computers">www.ti.com/computers</a>
Consumer Electronics	<a href="http://www.ti.com/consumer-apps">www.ti.com/consumer-apps</a>
Energy and Lighting	<a href="http://www.ti.com/energy">www.ti.com/energy</a>
Industrial	<a href="http://www.ti.com/industrial">www.ti.com/industrial</a>
Medical	<a href="http://www.ti.com/medical">www.ti.com/medical</a>
Security	<a href="http://www.ti.com/security">www.ti.com/security</a>
Space, Avionics and Defense	<a href="http://www.ti.com/space-avionics-defense">www.ti.com/space-avionics-defense</a>
Video and Imaging	<a href="http://www.ti.com/video">www.ti.com/video</a>

### TI E2E Community

[e2e.ti.com](http://e2e.ti.com)