

Precision 16-Channel/Dual 8-Channel CMOS Analog Multiplexers

DESCRIPTION

The DG506B and DG507B are high performance analog multiplexers. Their ultra-low switch charge injection, low channel capacitance, and low leakage level allows them to achieve superior switching performance. The DG506B is a 16-channel single-ended analog multiplexer designed to connect one of sixteen inputs to a common output as determined by a 4-bit binary address (A0, A1, A2, A3). The DG507B is a dual 8-channel differential analog multiplexer designed to connect one of eight differential inputs to a common dual output as determined by its 3-bit binary address (A0, A1, A2). Break-before-make switching action protects against momentary crosstalk between adjacent channels.

An on channel conducts current equally well in both directions. In the off state each channel blocks voltages up to the power supply rails. An enable (EN) function allows the user to reset the multiplexer/demultiplexer to all switches off for stacking several devices. All control inputs, addresses (Ax) and enable (EN) are TTL compatible over the full specified operating temperature range.

The DG506B and DG507B are fabricated on an enhanced SG-II CMOS process that achieves improved performance on: reduced charge injection, lower device leakage, and minimized parasitic capacitance.

As the DG506, DG507 has a long history in the industry with many suppliers offering copies, and in some cases improved variations, with the best in class improvements, the Vishay Siliconix new version of the DG506B, DG507B are the superior alternatives to what is currently available.

Applications for the DG506B, DG507B include high speed and high precision data acquisition, audio signal switching and routing, ATE systems, and avionics. High performance and low power dissipation make them ideal for battery operated and remote instrumentation applications.

The DG506B and DG507B have the absolute maximum voltage rating extended to 44 V. Additionally, single supply operation is also allowed. An epitaxial layer prevents latch-up.

The DG506B and DG507B are both available in 28-lead SOIC and TSSOP package options with extended temperature range of - 40 °C to + 125 °C.

For more information, refer to Vishay Siliconix DG506B, DG507B evaluation board note.

FEATURES

- Operate with single or dual power supply
- V+ to V- analog signal swing range
- 44 V power supply maximum rating
- Extended operate temperature range:
- 40 °C to + 125 °C
- Low leakage typically < 3 pA
- Low charge injection - $Q_{INJ} = 1$ pC
- Low power - $I_{SUPPLY} = 5$ μ A
- TTL compatible logic
- > 250 mA latch up current per JESD78
- Available in SOIC28 and TSSOP28 packages
- Superior alternative to:
- ADG506A, DG506A, HI-506
- ADG507A, DG507A, HI-507
- **Compliant to RoHS directive 2002/95/EC**
- **Halogen-free according to IEC 61249-2-21 definition**



RoHS
COMPLIANT
HALOGEN
FREE

BENEFITS

- Reduced switching errors
- Reduced glitching
- Improved data throughput
- Reduced power consumption
- Increased ruggedness
- Wide supply ranges (± 5 V to ± 20 V)

APPLICATIONS

- Data acquisition systems
- Audio and video signal routing
- ATE systems
- Medical instrumentation

FUNCTIONAL BLOCK DIAGRAM AND PIN CONFIGURATION

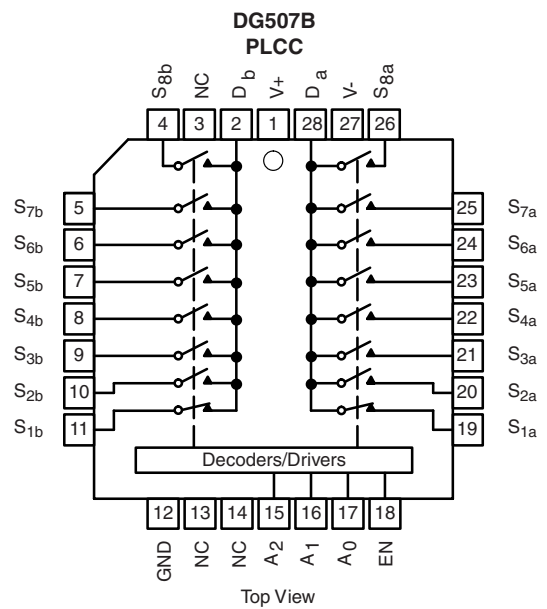
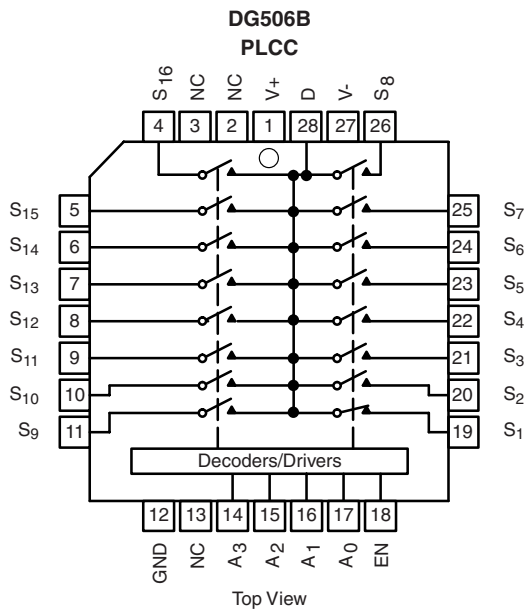
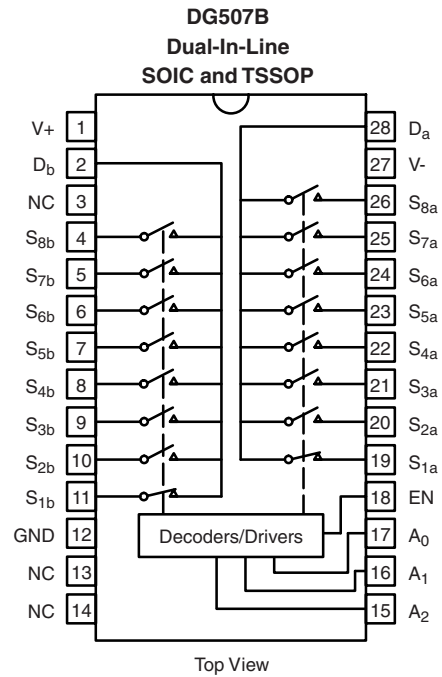
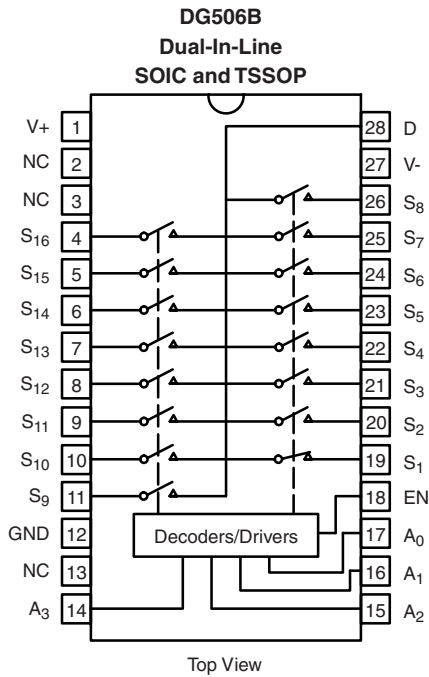

TRUTH TABLE DG506B					
A ₃	A ₂	A ₁	A ₀	EN	On Switch
X	X	X	X	0	None
0	0	0	0	1	1
0	0	0	1	1	2
0	0	1	0	1	3
0	0	1	1	1	4
0	1	0	0	1	5
0	1	0	1	1	6
0	1	1	0	1	7
1	1	1	1	1	8
1	0	0	0	1	9
1	0	0	1	1	10
1	0	1	0	1	11
1	0	1	1	1	12
1	1	0	0	1	13
1	1	0	1	1	14
1	1	1	0	1	15
1	1	1	1	1	16

TRUTH TABLE DG507B				
A ₂	A ₁	A ₀	EN	On Switch
X	X	X	0	None
0	0	0	1	1
0	0	0	1	2
0	1	1	1	3
0	1	1	1	4
1	0	0	1	5
1	0	0	1	6
1	1	1	1	7
1	1	1	1	8

 Logic "0" = $V_{IL} \leq 0.8 \text{ V}$

 Logic "1" = $V_{IH} \geq 2.4 \text{ V}$

X = Do not care

ORDERING INFORMATION DG506B		
Temp. Range	Package	Part Number
- 40 °C to 125 °C	28-Pin SOIC	DG506BEW-T1-GE3
	28-Pin TSSOP	DG506BEQ-T1-GE3
	28-Pin PLCC	DG506BEN-T1-GE3

ORDERING INFORMATION DG507B		
Temp. Range	Package	Part Number
- 40 °C to 125 °C	28-Pin SOIC	DG507BEW-T1-GE3
	28-Pin TSSOP	DG507BEQ-T1-GE3
	28-Pin PLCC	DG507BEN-T1-GE3

ABSOLUTE MAXIMUM RATINGS			
Parameter		Limit	Unit
Voltages Referenced to V-	V+	44	V
	GND	25	
Digital Inputs ^a , V _S , V _D		(V-) - 2 to (V+) + 2 or 20 mA, whichever occurs first	
Current (Any terminal)		30	mA
Peak Current, S or D (Pulsed at 1 ms, 10 % duty cycle max.)		100	
Storage Temperature	(EW, EQ, EN suffix)	- 65 to 150	°C
Power Dissipation (Packages) ^b	28-Pin Wide Body SOIC ^c	840	mW
	28-Pin TSSOP ^d	817	
	28-Pin PLCC ^e	1693	
Thermal Resistance (θ_{J-A}) ^b	28-Pin Wide Body SOIC ^c	95.3	°C/W
	28-Pin TSSOP ^d	97.9	
	28-Pin PLCC ^e	47.3	

Notes:

 a. Signals on S_X, D_X or IN_X exceeding V+ or V- will be clamped by internal diodes. Limit forward diode current to maximum current ratings.

b. All leads soldered or welded to PC board.

c. Derate 10.5 mW/°C above 70 °C.

d. Derate 10.2 mW/°C above 70 °C.

e. Derate 21.2 mW/°C above 70 °C.

SPECIFICATIONS										
Parameter	Symbol	Test Conditions Unless Otherwise Specified $V_+ = 15\text{ V}$, $V_- = -15\text{ V}$ ($\pm 10\%$) V_{AX} , $V_{EN} = 2.4\text{ V}$, 0.8 V^a	Temp. ^b	Typ. ^c	A Suffix -40 °C to 125 °C		D Suffix -40 °C to 85 °C		Unit	
					Min. ^d	Max. ^d	Min. ^d	Max. ^d		
Analog Switch										
Analog Signal Range ^e	V_{ANALOG}		Full		-15	15	-15	15	V	
Drain-Source On-Resistance	$R_{DS(on)}$	$V_D = \pm 10\text{ V}$, $I_S = -1\text{ mA}$	Room	170		300		300	Ω	
			Full			400		400		
$R_{DS(on)}$ Matching	$\Delta R_{DS(on)}$	$V_D = \pm 10\text{ V}$	Room	10						
Source Off Leakage Current	$I_{S(off)}$	$V_D = \pm 10\text{ V}$ $V_S = \mp 10\text{ V}$ $V_{EN} = 0\text{ V}$	Room	0.005	-1	1	-1	1	nA	
Drain Off Leakage Current	$I_{D(off)}$		DG506B	Room	0.005	-1	1	-1		1
				Full		-100	100	-100		100
			DG507B	Room	0.005	-1	1	-1		1
				Full		-50	50	-50		50
Drain On Leakage Current	$I_{D(on)}$		DG506B	Room	0.005	-1	1	-1		1
		Full			-100	100	-100	100		
		DG507B	Room	0.005	-1	1	-1	1		
			Full		-50	50	-50	50		
Digital Control										
Logic High Input Voltage	V_{INH}		Full		2.4		2.4		V	
Logic Low Input Voltage	V_{INL}		Full			0.8		0.8		
Logic High Input Current	I_{IH}	V_{AX} , $V_{EN} = 2.4\text{ V}$	Full		-1	1	-1	1	μA	
Logic Low Input Current	I_{IL}	V_{AX} , $V_{EN} = 0.8\text{ V}$	Full		-1	1	-1	1		
Logic Input Capacitance ^e	C_{in}	$f = 1\text{ MHz}$	Room	5					pF	
Dynamic Characteristics										
Transition Time	t_{TRANS}	$V_{S1} = +10\text{ V}/-10\text{ V}$, $V_{S16} = -10\text{ V}/+10\text{ V}$, $R_L = 1\text{ M}\Omega$, $C_L = 35\text{ pF}$ see figure 2	Room	190		300		300		
			Full			360		360		
Break-Before-Make Interval	t_{OPEN}	$V_{S1} = V_{S16} = 5.0\text{ V}$, $C_L = 35\text{ pF}$, $R_L = 1\text{ k}\Omega$, see figure 4	Room	84	30		30		ns	
			Full		10		10			
Enable Turn-On Time	$t_{ON(EN)}$	$V_{S1} = 5\text{ V}$, V_{S2} to $V_{S16} = 0\text{ V}$, $R_L = 1\text{ k}\Omega$, $C_L = 35\text{ pF}$ see figure 3	Room	151		250		250		
			Full			310		310		
Enable Turn-Off Time	$t_{OFF(EN)}$		Room	53		200		200		
			Full			220		220		
Charge Injection ^e	Q_{INJ}	$C_L = 1\text{ nF}$, $R_{GEN} = 0\ \Omega$, $V_{GEN} = 0\text{ V}$	Full	1					pC	
Off Isolation ^e	OIRR	$C_L = 5\text{ pF}$, $R_L = 50\ \Omega$, $f = 1\text{ MHz}$	DG506B	Room	-85				dB	
			DG507B		-84					
Crosstalk ^e	XTALK	$C_L = 5\text{ pF}$, $R_L = 50\ \Omega$, $f = 1\text{ MHz}$	DG506B	Room	-85					
			DG507B		-84					
-3 dB Bandwidth ^e	BW	$R_L = 50\ \Omega$	DG506B	Room	114				MHz	
			DG507B		217					
Total Harmonic Distortion ^e	THD	$R_L = 10\text{ k}\Omega$, 5 V_{rms}	Room	0.04					%	
Source Off Capacitance ^e	$C_{S(off)}$	$f = 1\text{ MHz}$	Room	3					pF	
Drain Off Capacitance ^e	$C_{D(off)}$		DG506B	Room	31					
			DG507B	Room	17					
Drain On Capacitance ^e	$C_{D(on)}$		DG506B	Room	38					
			DG507B	Room	24					
Power Supply										
Positive Supply Current	I_+	V_{AX} , $V_{EN} = 0\text{ V}$ or 5 V	Room	0.005		0.1		0.1	mA	
			Full			0.1		0.1		
Negative Supply Current	I_-		Full		-1		-1		μA	



SPECIFICATIONS Single Supply 12 V										
Parameter	Symbol	Test Conditions Unless Otherwise Specified $V_+ = 12\text{ V}$, $V_- = 0\text{ V}$ ($\pm 10\%$) V_{AX} , $V_{EN} = 2.4\text{ V}$, 0.8 V^a	Temp. ^b	Typ. ^c	A Suffix - 40 °C to 125 °C		D Suffix - 40 °C to 85 °C		Unit	
					Min. ^d	Max. ^d	Min. ^d	Max. ^d		
Analog Switch										
Analog Signal Range ^e	V_{ANALOG}		Full		0	12	0	12	V	
On-Resistance	$R_{DS(on)}$	$V_D = 10\text{ V}/0\text{ V}$, $I_S = 1\text{ mA}$	Room	270		450		450	Ω	
$R_{DS(on)}$ Matching	$\Delta R_{DS(on)}$		Full			650		650		
Switch Off Leakage Current	$I_{S(off)}$	$V_+ = 12\text{ V}$, $V_- = 0\text{ V}$ $V_D = 0\text{ V}/10\text{ V}$, $V_S = 10\text{ V}/0\text{ V}$	Room	0.005	- 1	1	- 1	1	nA	
			Full			- 50	- 50	- 50		50
	$I_{D(off)}$		DG506B	Room	0.005	- 1	1	- 1		1
			Full			- 100	100	- 100		100
	$I_{D(off)}$		DG507B	Room	0.005	- 1	1	- 1		1
			Full			- 50	50	- 50		50
Channel On Leakage Current	$I_{D(on)}$	$V_+ = 12\text{ V}$, $V_- = 0\text{ V}$ $V_S = V_D = 0\text{ V}/10\text{ V}$	DG506B	Room	0.005	- 1	1	- 1	1	
			Full			- 100	100	- 100	100	
			DG507B	Room	0.005	- 1	1	- 1	1	
			Full			- 50	50	- 50	50	
Digital Control										
Logic High Input Voltage	V_{INH}		Full		2.4		2.4		V	
Logic Low Input Voltage	V_{INL}		Full			0.8		0.8		
Logic High Input Current	I_{IH}	V_{AX} , $V_{EN} = 2.4\text{ V}$	Full		- 1	1	- 1	1	μA	
Logic Low Input Current	I_{IL}	V_{AX} , $V_{EN} = 0.8\text{ V}$	Full		- 1	1	- 1	1		
Logic Input Capacitance ^e	C_{in}	$f = 1\text{ MHz}$	Room	5					pF	
Dynamic Characteristics										
Transition Time	t_{TRANS}	$V_{S1} = 10\text{ V}/0\text{ V}$, $V_{S16} = 0\text{ V}/10\text{ V}$, $R_L = 1\text{ M}\Omega$, $C_L = 35\text{ pF}$, see figure 2	Room	228		380		380	ns	
			Full			450		450		
Break-Before-Make Interval	t_{OPEN}	$V_{S1} = V_{S16} = 5\text{ V}$, $C_L = 35\text{ pF}$, $R_L = 1\text{ k}\Omega$, see figure 4	Room	115	40		40			
			Full		10		10			
Enable Turn-On Time	$t_{ON(EN)}$	$V_{S1} = 5\text{ V}$, V_{S2} to $V_{S16} = 0\text{ V}$, $R_L = 1\text{ k}\Omega$, $C_L = 35\text{ pF}$ see figure 3	Room	197		300		300		
			Full			420		420		
Enable Turn-Off Time	$t_{OFF(EN)}$		Room	46		200		200		
			Full			220		220		
Charge Injection ^e	Q_{INJ}	$C_L = 1\text{ nF}$, $R_{GEN} = 0\ \Omega$, $V_{GEN} = 0\text{ V}$	Full	4					pC	
Off Isolation ^e	OIRR	$C_L = 5\text{ pF}$, $R_L = 50\ \Omega$ $f = 1\text{ MHz}$	DG506B	Room	- 86				dB	
			DG507B		- 84					
Crosstalk ^e	X_{TALK}	$C_L = 5\text{ pF}$, $R_L = 50\ \Omega$ $f = 1\text{ MHz}$	DG506B	Room	- 85				dB	
			DG507B		- 84					
- 3 dB Bandwidth ^e	BW	$R_L = 50\ \Omega$	DG506B	Room	104				MHz	
			DG507B		191					
Total Harmonic Distortion ^e	THD	$R_L = 10\text{ k}\Omega$, 5 V_{RMS} , $f = 20\text{ Hz}$ to 20 kHz	Room	0.23					%	

SPECIFICATIONS Single Supply 12 V										
Parameter	Symbol	Test Conditions Unless Otherwise Specified $V_+ = 12\text{ V}$, $V_- = 0\text{ V}$ ($\pm 10\%$) V_{AX} , $V_{EN} = 2.4\text{ V}$, 0.8 V^a	Temp. ^b	Typ. ^c	A Suffix - 40 °C to 125 °C		D Suffix - 40 °C to 85 °C		Unit	
					Min. ^d	Max. ^d	Min. ^d	Max. ^d		
Dynamic Characteristics										
Source Off Capacitance ^e	$C_{S(off)}$	f = 1 MHz	Room	4					pF	
Drain Off Capacitance ^e	$C_{D(off)}$			DG506B	37					
				DG507B	20					
Channel On Capacitance ^e	$C_{D(on)}$			DG506B	43					
		DG507B	26							
Power Supply										
Power Supply Current	I_+	V_{AX} , $V_{EN} = 0\text{ V}$, or 5 V	Room	0.005		0.1		0.1	mA	
			Full			0.1		0.1		

Notes:

- a. V_{AX} , V_{EN} = input voltage perform proper function.
- b. Room = 25 °C, Full = as determined by the operating temperature suffix.
- c. Typical values are for DESIGN AID ONLY, not guaranteed nor subject to production testing.
- d. The algebraic convention whereby the most negative value is a minimum and the most positive a maximum, is used in this datasheet.
- e. Guaranteed by design, not subject to production test.
- f. $\Delta R_{DS(on)} = R_{DS(on)} \text{ max.} - R_{DS(on)} \text{ min.}$

Stresses beyond those listed under "Absolute Maximum Ratings" may cause permanent damage to the device. These are stress ratings only, and functional operation of the device at these or any other conditions beyond those indicated in the operational sections of the specifications is not implied. Exposure to absolute maximum rating conditions for extended periods may affect device reliability.

SCHEMATIC DIAGRAM Typical Channel

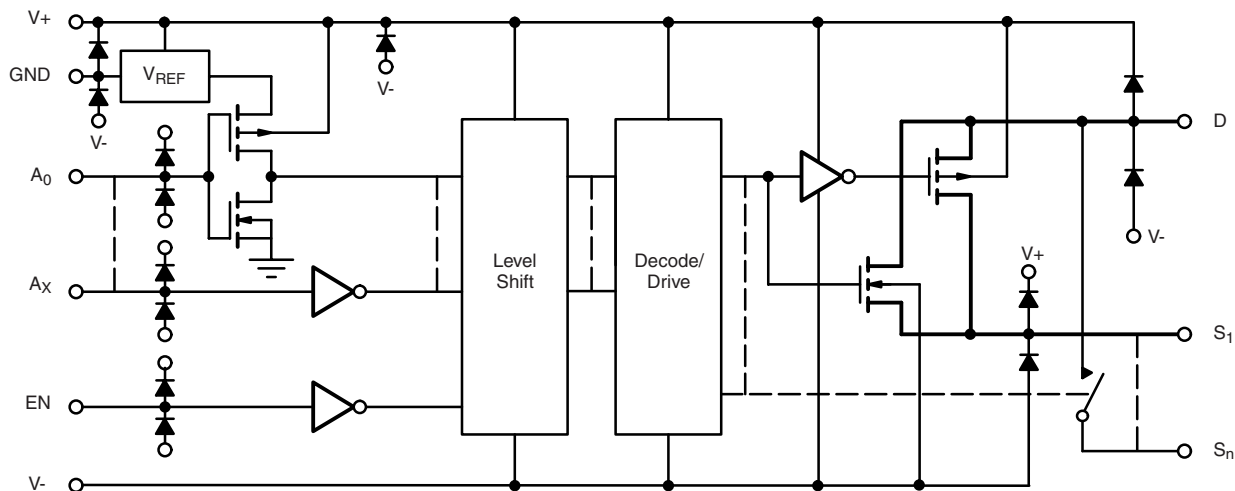
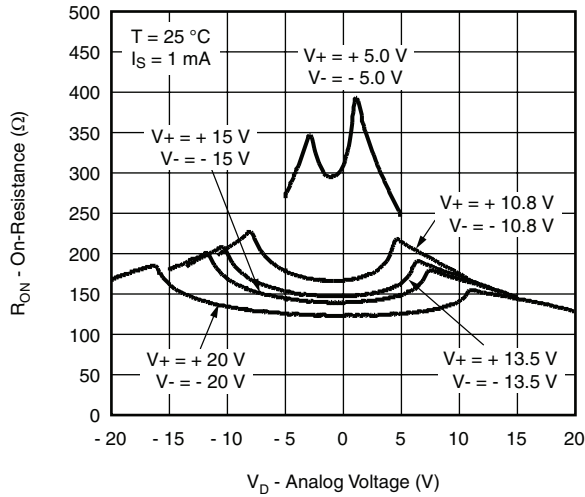
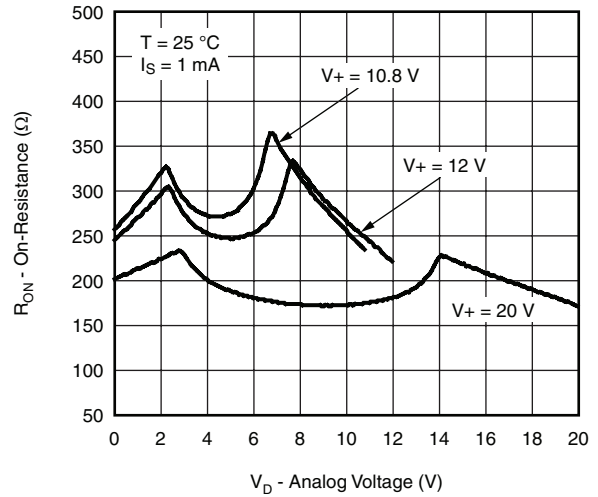

Figure 1.

TYPICAL CHARACTERISTICS 25 °C, unless otherwise noted



On-Resistance vs. V_D and Dual Supply Voltage



On-Resistance vs. V_D and Single Supply Voltage

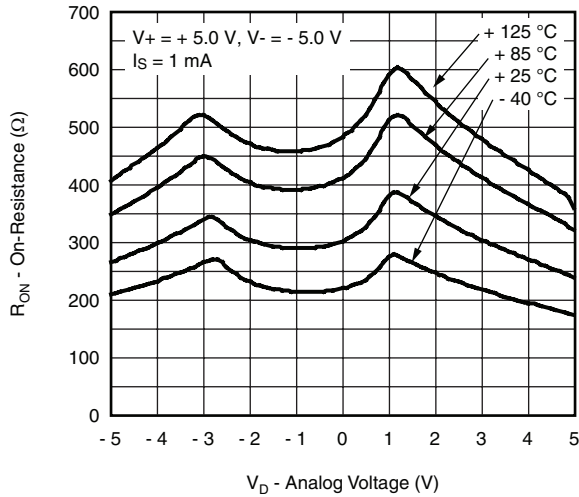

On-Resistance vs. Analog Voltage and Temperature

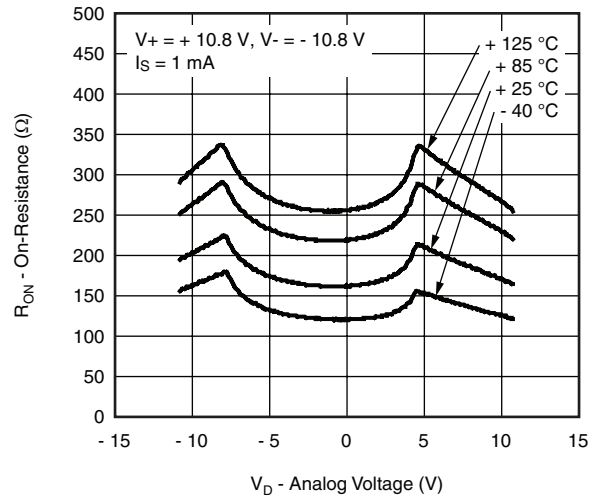

On-Resistance vs. Analog Voltage and Temperature

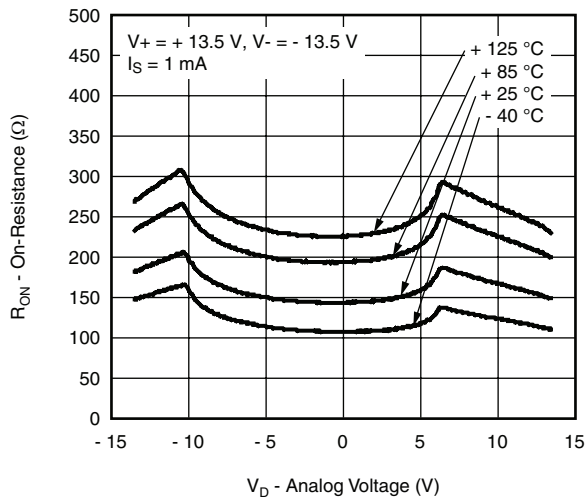

On-Resistance vs. Analog Voltage and Temperature

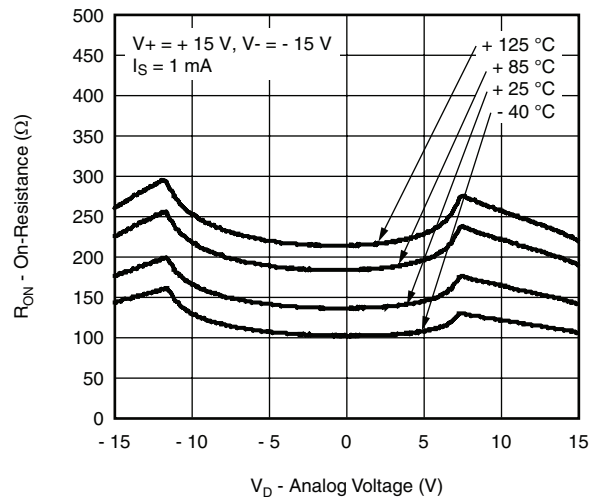

On-Resistance vs. Analog Voltage and Temperature

TYPICAL CHARACTERISTICS 25 °C, unless otherwise noted

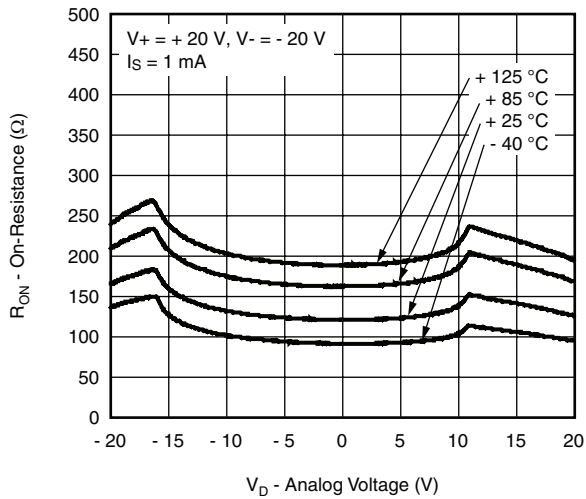

On-Resistance vs. Analog Voltage and Temperature

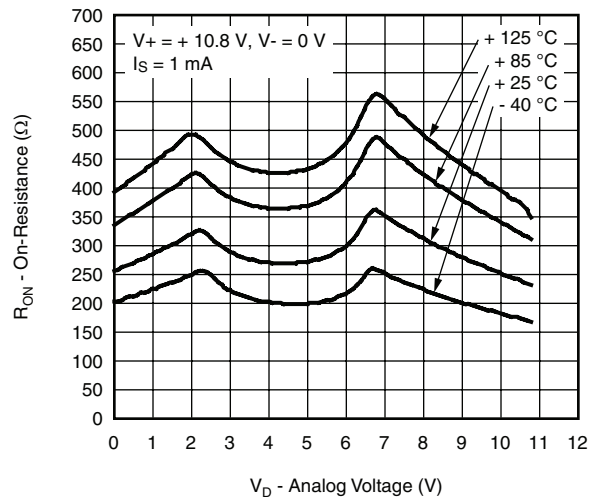

On-Resistance vs. Analog Voltage and Temperature

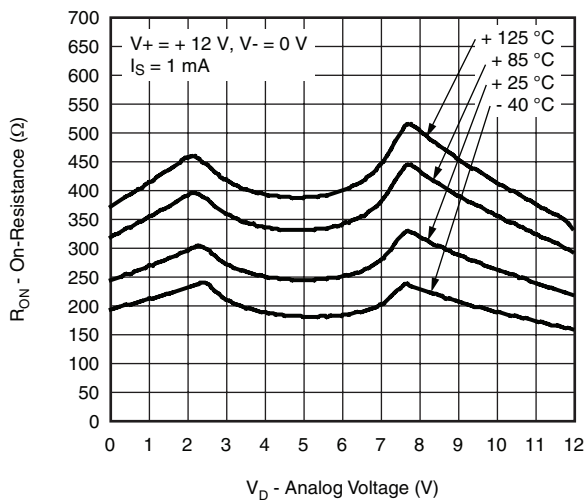

On-Resistance vs. Analog Voltage and Temperature

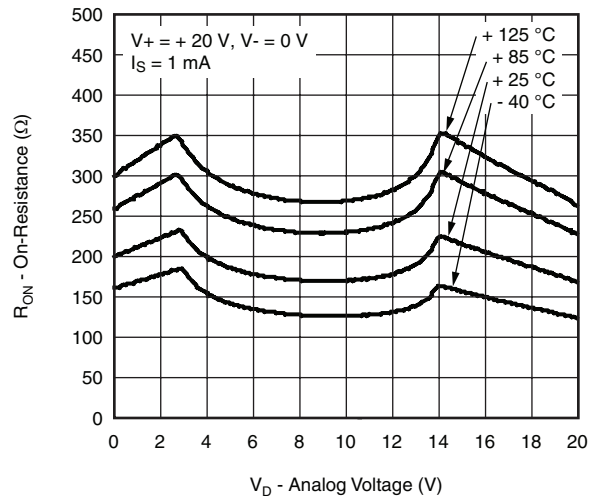

On-Resistance vs. Analog Voltage and Temperature

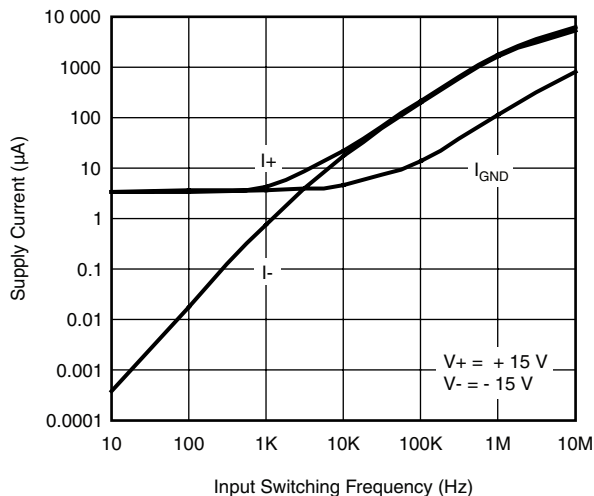

Supply Current vs. Input Switching Frequency

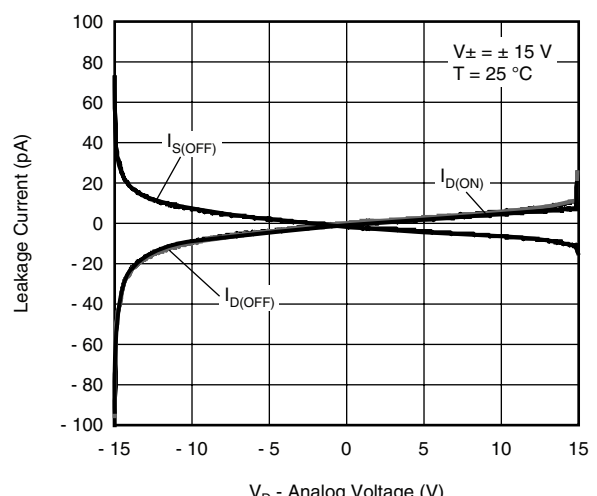

Leakage Current vs. Analog Voltage

TYPICAL CHARACTERISTICS 25 °C, unless otherwise noted

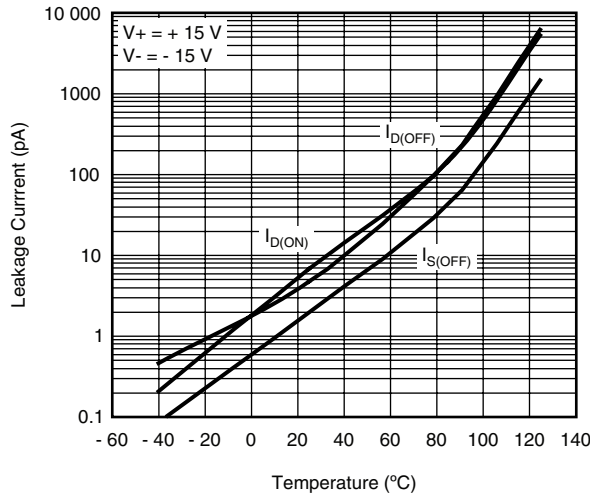

Leakage Current vs. Temperature

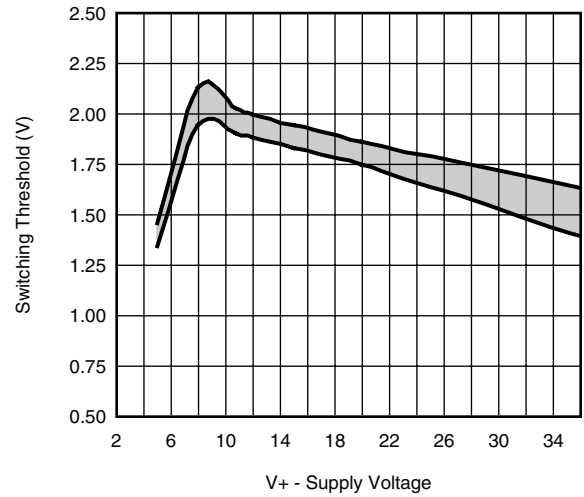

Switching Threshold vs. Single Supply V

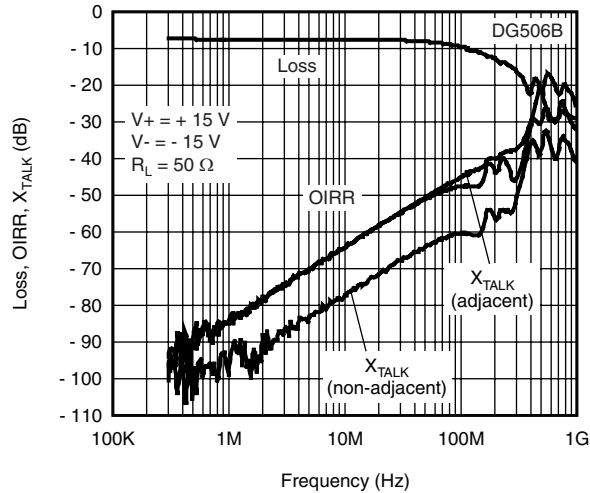

Insertion Loss, Off-Isolation, Crosstalk vs. Frequency

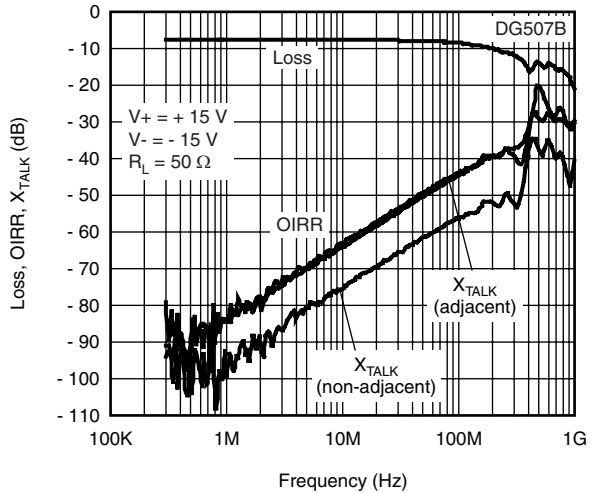

Insertion Loss, Off-Isolation, Crosstalk vs. Frequency

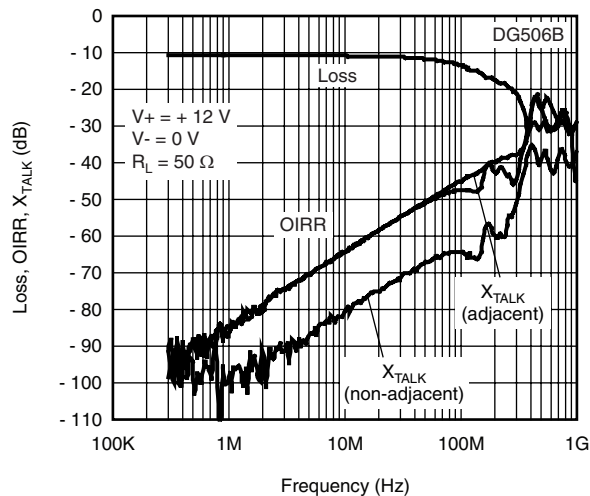

Insertion Loss, Off-Isolation, Crosstalk vs. Frequency

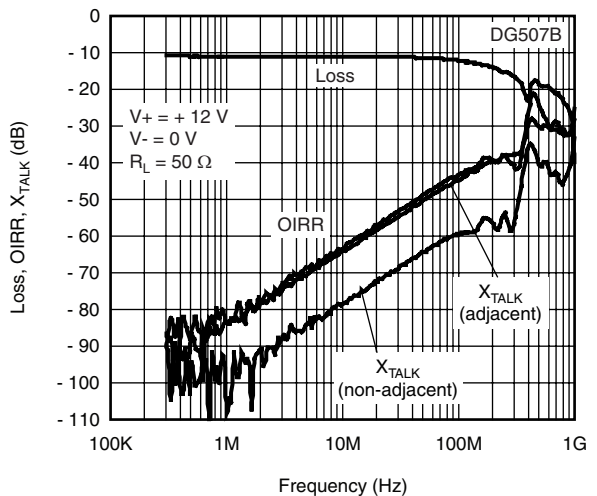

Insertion Loss, Off-Isolation, Crosstalk vs. Frequency

TYPICAL CHARACTERISTICS 25 °C, unless otherwise noted

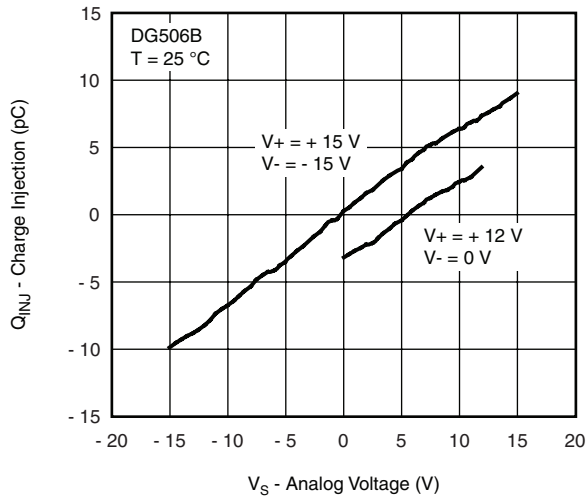

Charge Injection vs. Analog Voltage

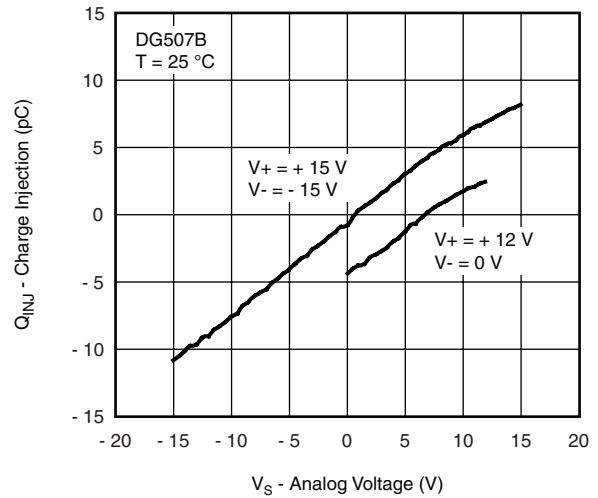

Charge Injection vs. Analog Voltage

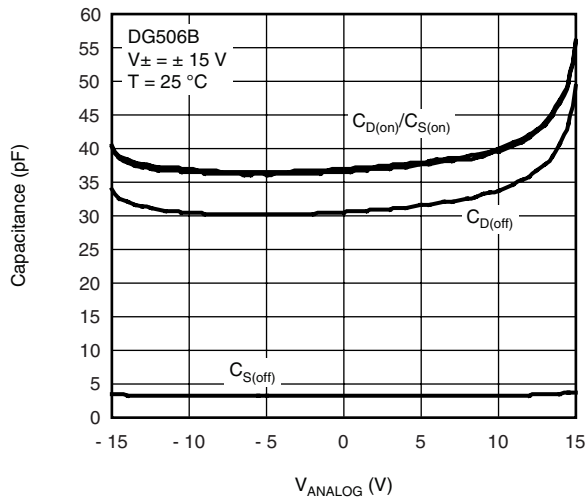

Capacitance vs. V_{ANALOG}

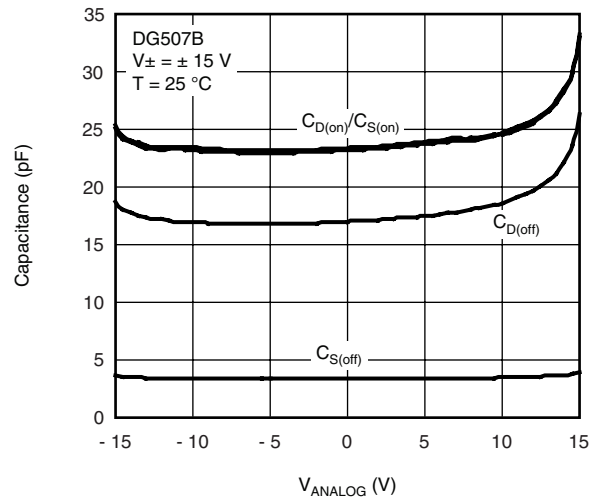

Capacitance vs. V_{ANALOG}

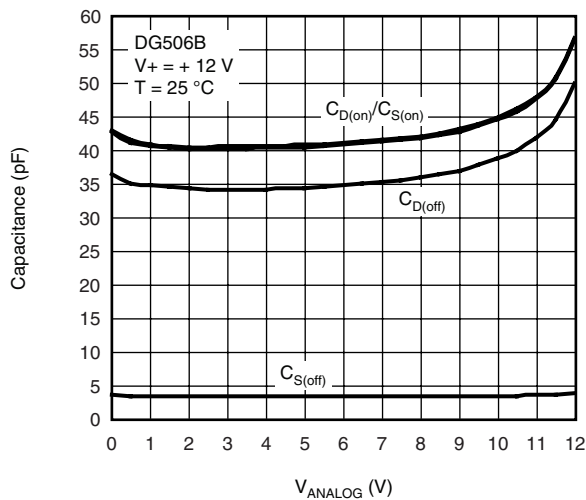

Capacitance vs. V_{ANALOG}

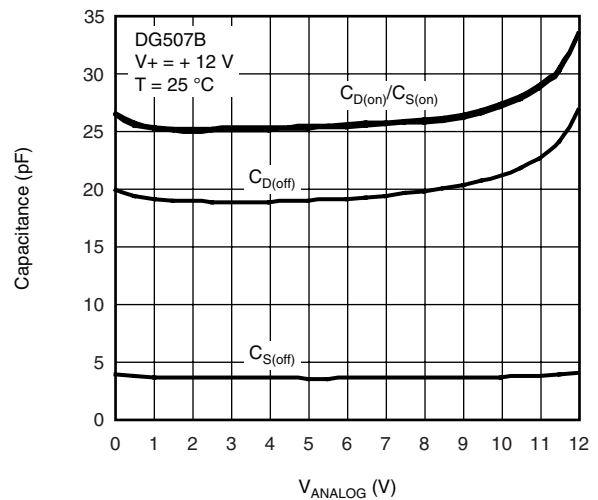

Capacitance vs. V_{ANALOG}

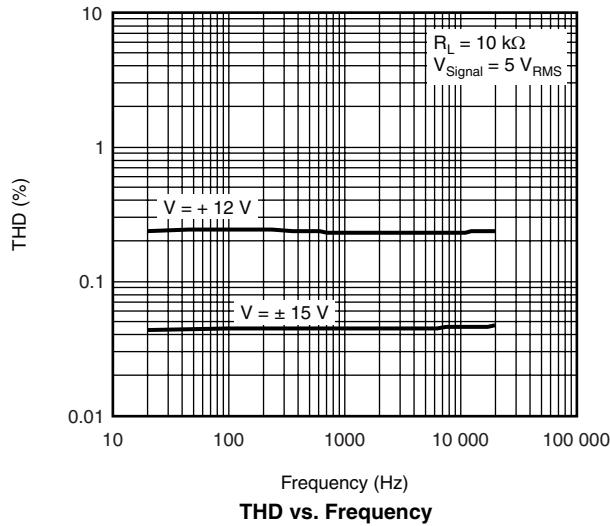
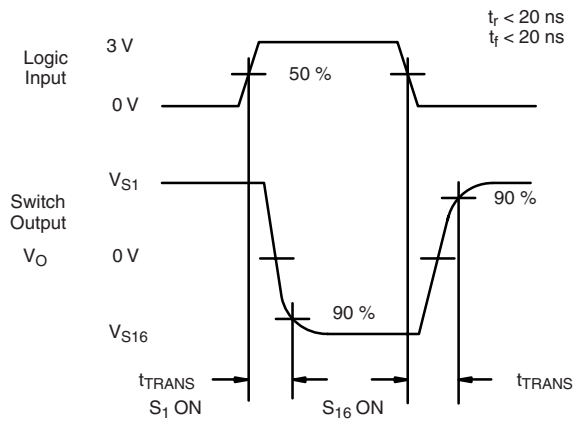
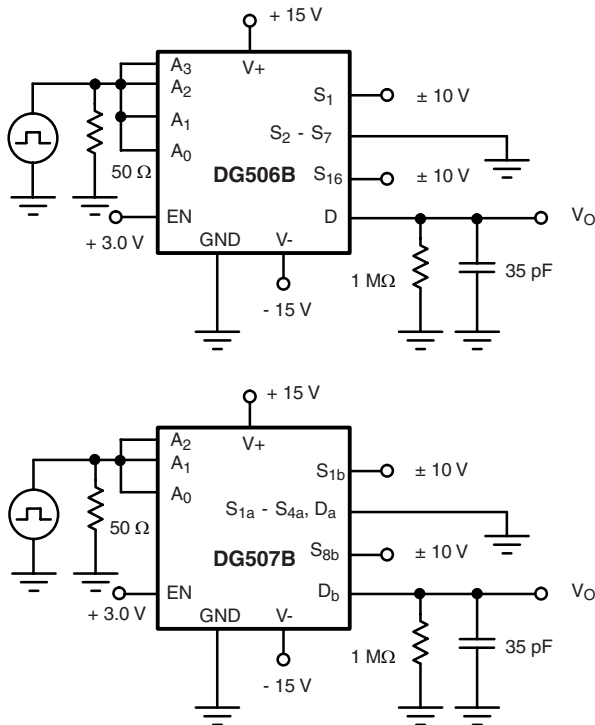
TYPICAL CHARACTERISTICS 25 °C, unless otherwise noted

TEST CIRCUITS

Figure 2. Transition Time

TEST CIRCUITS

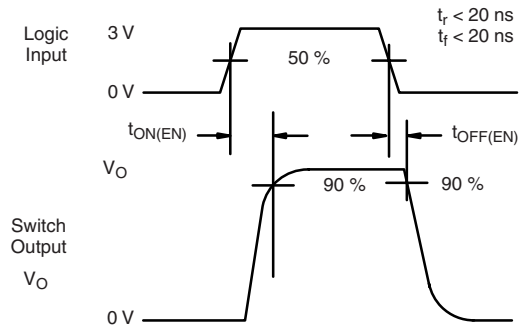
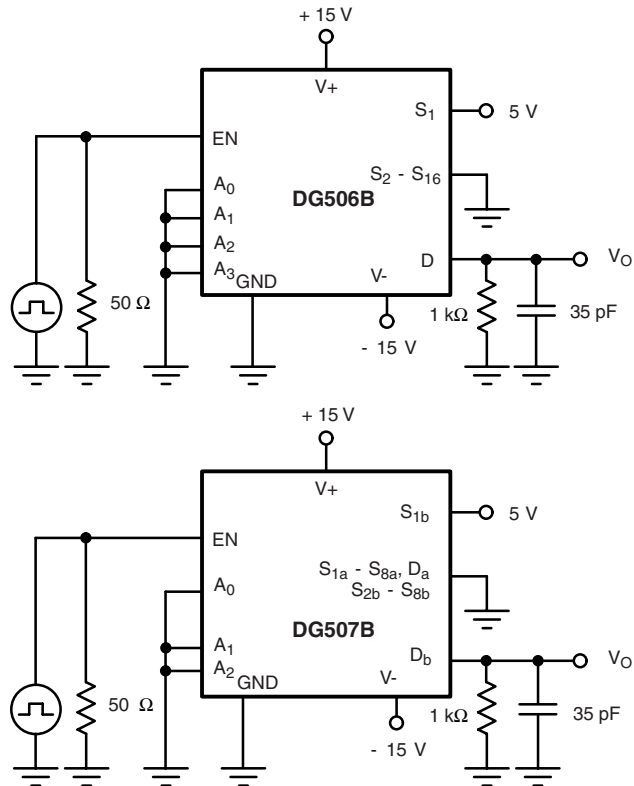

Figure 3. Enable Switching Time

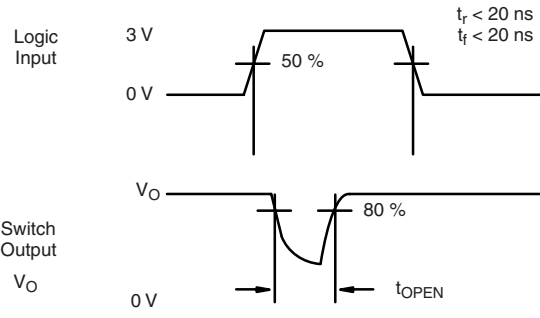
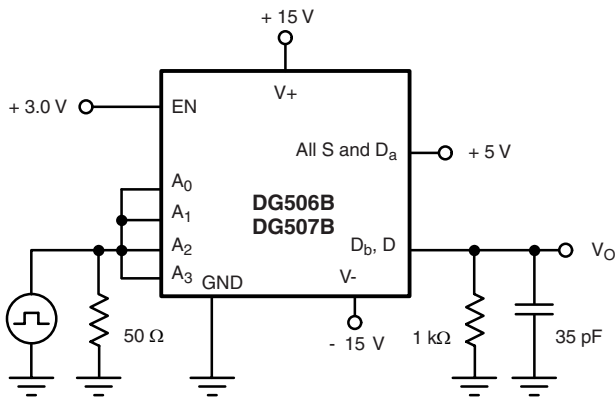
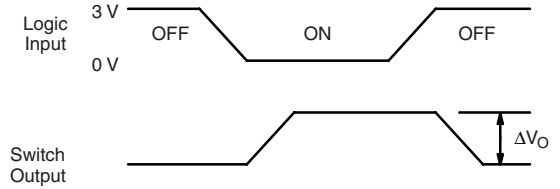
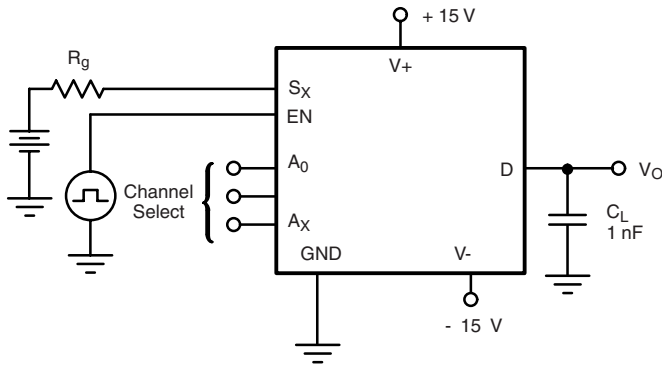
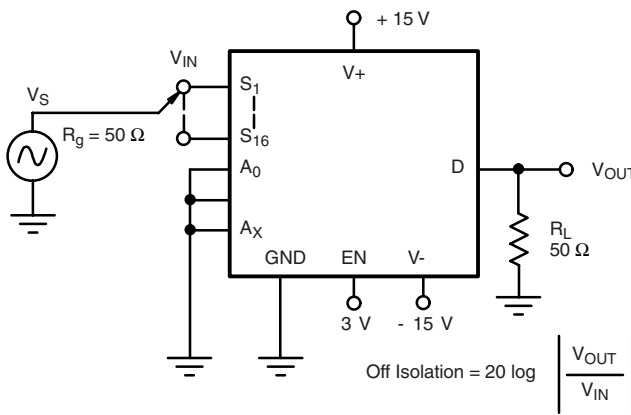
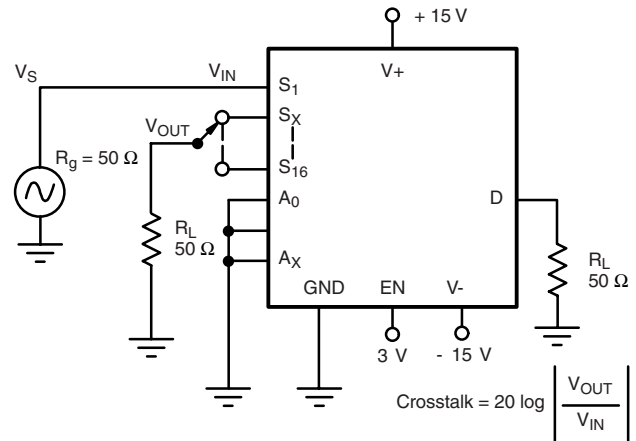
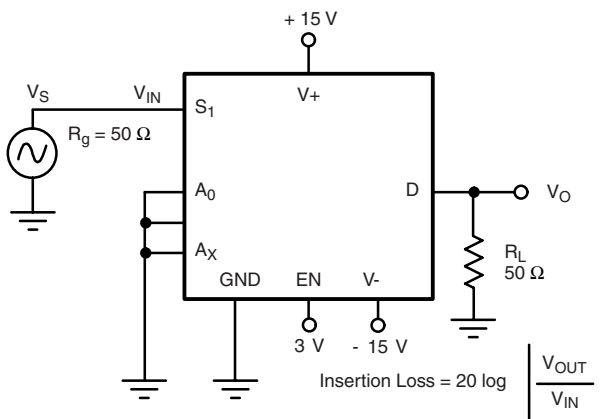
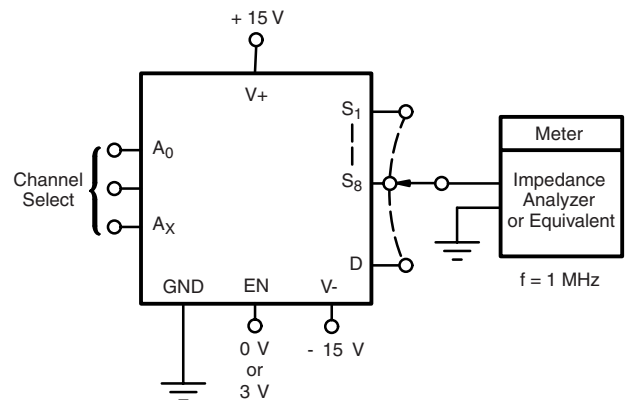

Figure 4. Break-Before-Make Interval

TEST CIRCUITS

ΔV_O is the measured voltage due to charge transfer error Q , when the channel turns off.

$$Q_{INJ} = C_L \times \Delta V_O$$

Figure 5. Charge Injection

Figure 6. Off Isolation

Figure 7. Crosstalk

Figure 8. Insertion Loss

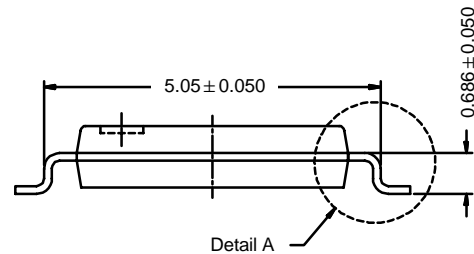
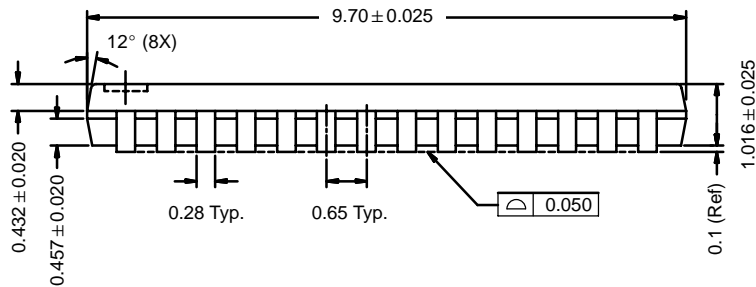
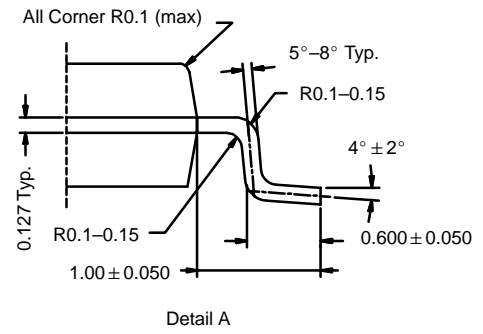
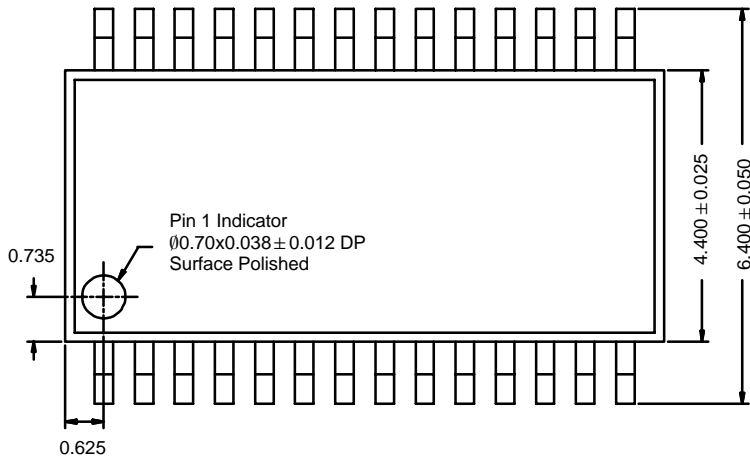
Figure 9. Source Drain Capacitance

Vishay Siliconix maintains worldwide manufacturing capability. Products may be manufactured at one of several qualified locations. Reliability data for Silicon Technology and Package Reliability represent a composite of all qualified locations. For related documents such as package/tape drawings, part marking, and reliability data, see www.vishay.com/ppg?65150.



TSSOP: 28-LEAD



ECN: S-03946—Rev. C, 09-Jul-01
DWG: 5851

NOTES:

1. Package Surface: Shiny Finish (Ro 0.15 – 0.20).
2. Package Warpage: 0.012 (max).
3. Package Corner Radius: R0.1 mm (max).
4. Top to BTM Cavity Mismatch: 0.037 (max).
5. Tolerance: ± 0.050 unless otherwise specified.
6. End Flash Max: 0.1016 mm.



PLCC: 28-LEAD

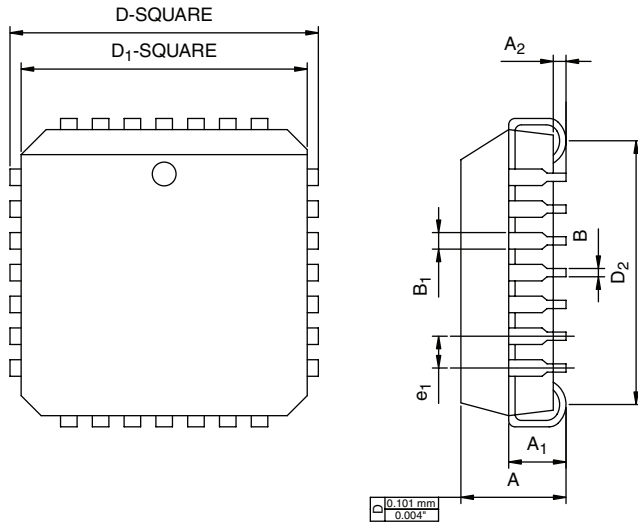

DIM.	MILLIMETERS		INCHES	
	MIN.	MAX.	MIN.	MAX.
A	4.20	4.57	0.165	0.180
A ₁	2.29	3.04	0.090	0.120
A ₂	0.51	-	0.020	-
B	0.331	0.553	0.013	0.021
B ₁	0.661	0.812	0.026	0.032
D	12.32	12.57	0.485	0.495
D ₁	11.430	11.582	0.450	0.456
D ₂	9.91	10.92	0.390	0.430
e ₁	1.27 BSC		0.050 BSC	
ECN: T09-0766-Rev. D, 28-Sep-09 DWG: 5491				



SOIC (WIDE-BODY): 28-LEADS

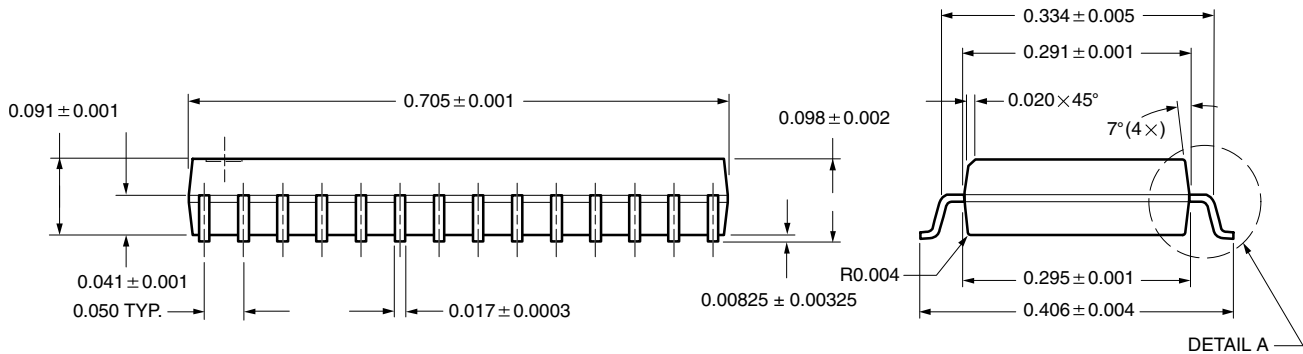
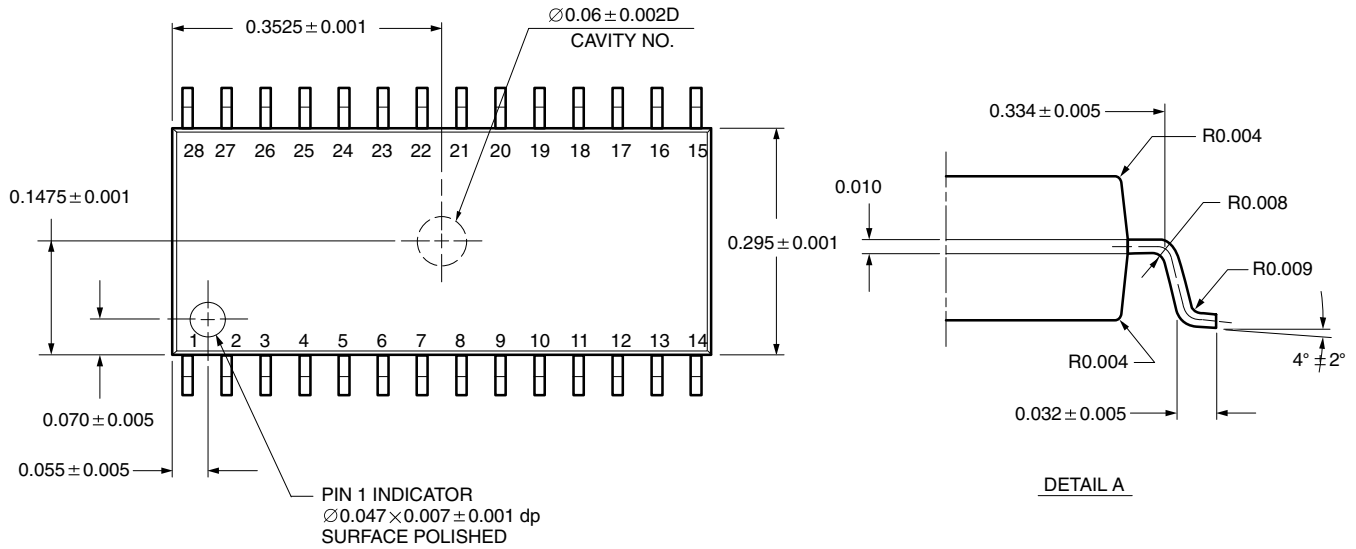

All Dimensions In Inches

ECN: E11-2209-Rev. D, 01-Aug-11
DWG: 5850



Disclaimer

ALL PRODUCT, PRODUCT SPECIFICATIONS AND DATA ARE SUBJECT TO CHANGE WITHOUT NOTICE TO IMPROVE RELIABILITY, FUNCTION OR DESIGN OR OTHERWISE.

Vishay Intertechnology, Inc., its affiliates, agents, and employees, and all persons acting on its or their behalf (collectively, "Vishay"), disclaim any and all liability for any errors, inaccuracies or incompleteness contained in any datasheet or in any other disclosure relating to any product.

Vishay makes no warranty, representation or guarantee regarding the suitability of the products for any particular purpose or the continuing production of any product. To the maximum extent permitted by applicable law, Vishay disclaims (i) any and all liability arising out of the application or use of any product, (ii) any and all liability, including without limitation special, consequential or incidental damages, and (iii) any and all implied warranties, including warranties of fitness for particular purpose, non-infringement and merchantability.

Statements regarding the suitability of products for certain types of applications are based on Vishay's knowledge of typical requirements that are often placed on Vishay products in generic applications. Such statements are not binding statements about the suitability of products for a particular application. It is the customer's responsibility to validate that a particular product with the properties described in the product specification is suitable for use in a particular application. Parameters provided in datasheets and/or specifications may vary in different applications and performance may vary over time. All operating parameters, including typical parameters, must be validated for each customer application by the customer's technical experts. Product specifications do not expand or otherwise modify Vishay's terms and conditions of purchase, including but not limited to the warranty expressed therein.

Except as expressly indicated in writing, Vishay products are not designed for use in medical, life-saving, or life-sustaining applications or for any other application in which the failure of the Vishay product could result in personal injury or death. Customers using or selling Vishay products not expressly indicated for use in such applications do so at their own risk and agree to fully indemnify and hold Vishay and its distributors harmless from and against any and all claims, liabilities, expenses and damages arising or resulting in connection with such use or sale, including attorneys fees, even if such claim alleges that Vishay or its distributor was negligent regarding the design or manufacture of the part. Please contact authorized Vishay personnel to obtain written terms and conditions regarding products designed for such applications.

No license, express or implied, by estoppel or otherwise, to any intellectual property rights is granted by this document or by any conduct of Vishay. Product names and markings noted herein may be trademarks of their respective owners.

Material Category Policy

Vishay Intertechnology, Inc. hereby certifies that all its products that are identified as RoHS-Compliant fulfill the definitions and restrictions defined under Directive 2011/65/EU of The European Parliament and of the Council of June 8, 2011 on the restriction of the use of certain hazardous substances in electrical and electronic equipment (EEE) - recast, unless otherwise specified as non-compliant.

Please note that some Vishay documentation may still make reference to RoHS Directive 2002/95/EC. We confirm that all the products identified as being compliant to Directive 2002/95/EC conform to Directive 2011/65/EU.