

8-Channel, Dual 4-Channel, Triple 2-Channel (Triple SPDT) Multiplexers

DESCRIPTION

The DG4051A, DG4052A and DG4053A are high precision CMOS analog multiplexers. The DG4051A is an 8-channel multiplexer, the DG4052A is a dual 4-channel multiplexer and the DG4053A is a triple 2-channel multiplexer or triple SPDT.

Designed to operate from a + 2.7 V to + 12 V single supply or from a ± 2.5 V to ± 5 V dual supplies, the DG4051A, DG4052A and DG4053A are fully specified at + 3 V, + 5 V and ± 5 V. All control logic inputs have guaranteed 2.0 V logic high limit when operating from + 5 V or ± 5 V supplies and 1.4 V when operating from a + 3 V supply.

Channel leakage is typically in the range of 10 pA, and switch charge injection is less than 0.5 pC. Coupled with very low switch capacitance, these devices are ideal for high precision signal switching and multiplexing.

All switches conduct equally well in both directions, offering rail to rail analog signal switching and can be used both as multiplexers as well as de-multiplexers.

The DG4051A, DG4052A and DG4053A operating temperature is specified from - 40 °C to + 125 °C and are available in 16 pin TSSOP and the ultra compact 1.8 mm x 2.6 mm miniQFN16 packages.

FEATURES

- + 2.7 V to + 12 V single supply operation
- ± 2.5 V to ± 5 V dual supply operation
- Fully specified at + 3 V, + 5 V, ± 5 V
- 100 Ω maximum on-resistance
- Low voltage, 2.5 V CMOS/TTL compatible
- Low charge injection (< 0.5 pC typ.)
- High - 3 dB bandwidth: 330 MHz to 700 MHz
- Low switch capacitance ($C_{S(off)}$ 3 pF typ.)
- Excellent isolation and crosstalk performance (typ. 47 dB at 100 MHz)
- 16 pin SOIC, TSSOP and miniQFN package (1.8 mm x 2.6 mm)
- Fully specified from - 40 °C to + 85 °C and - 40 °C to + 125 °C
- Compliant to RoHS directive 2002/95/EC



RoHS
COMPLIANT

APPLICATIONS

- Instruments
- Healthcare and medical equipments
- Touch panel
- Automated test equipment
- Automation and control
- High precision data acquisition
- Communication system

FUNCTIONAL BLOCK DIAGRAM AND PIN CONFIGURATION

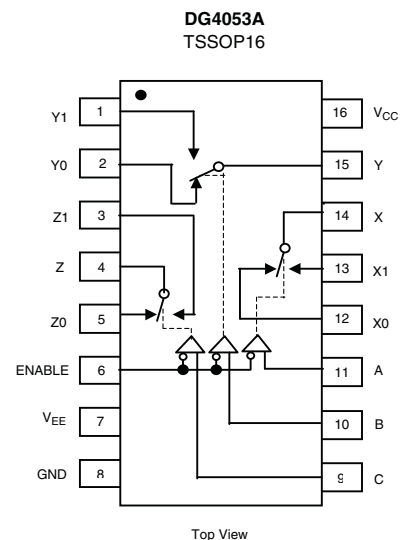
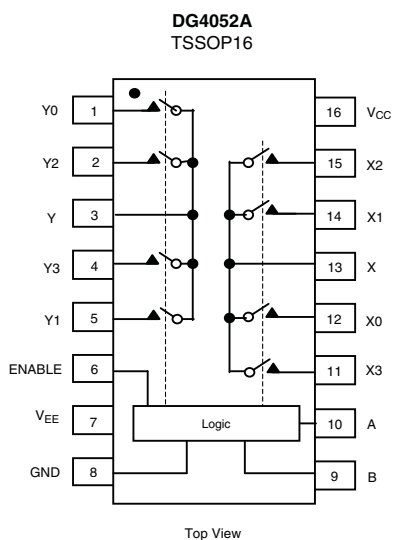
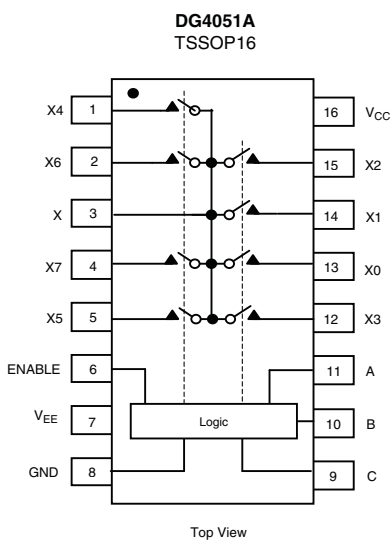

ENABLE = LO, all switches are controlled by addr pins.
ENABLE = HI, all switches are off.

FUNCTIONAL BLOCK DIAGRAM AND PIN CONFIGURATION

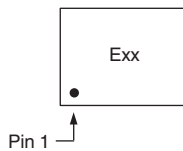
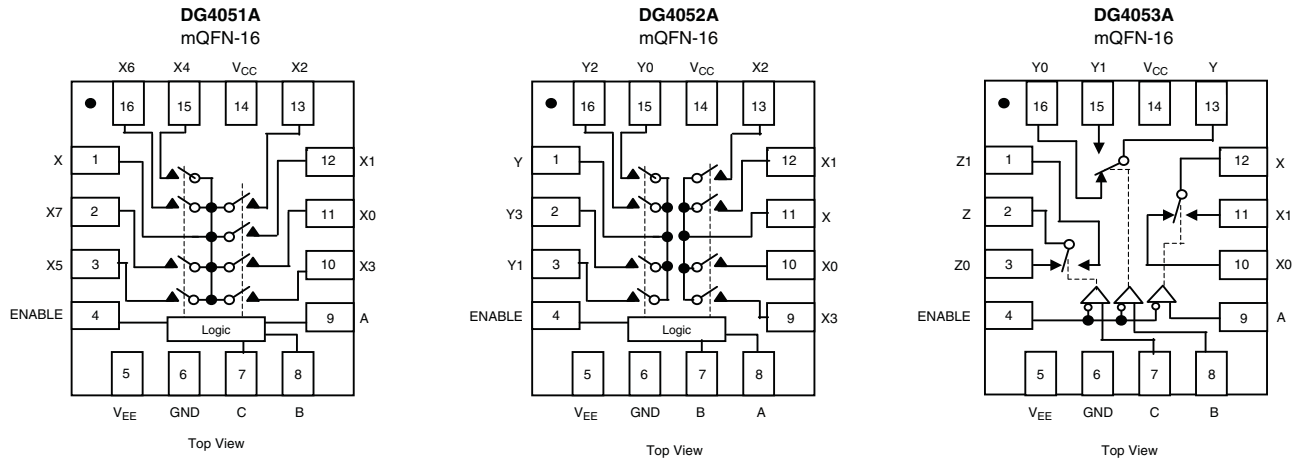

Device Marking: Exx for DG4051A (miniQFN16) Fxx for DG4052A Gxx for DG4053A
xx = Date/Lot Traceability Code

TRUTH TABLE						
Enable Input	Select Inputs			On Switches		
	C	B	A	DG4051A	DG4052A	DG4053A
H	X	X	X	All Switches Open	All Switches Open	All Switches Open
L	L	L	L	X to X0	X to X0, Y to Y0	X to X0, Y to Y0, Z to Z0
L	L	L	H	X to X1	X to X1, Y to Y1	X to X1, Y to Y0, Z to Z0
L	L	H	L	X to X2	X to X2, Y to Y2	X to X0, Y to Y1, Z to Z0
L	L	H	H	X to X3	X to X3, Y to Y3	X to X1, Y to Y1, Z to Z0
L	H	L	L	X to X4	X to X0, Y to Y0	X to X0, Y to Y0, Z to Z1
L	H	L	H	X to X5	X to X1, Y to Y1	X to X1, Y to Y0, Z to Z1
L	H	H	L	X to X6	X to X2, Y to Y2	X to X0, Y to Y1, Z to Z1
L	H	H	H	X to X7	X to X3, Y to Y3	X to X1, Y to Y1, Z to Z1

ORDERING INFORMATION		
Temp Range	Package	Part Number
DG4051A, DG4052A, DG4053A		
- 40 °C to 125 °C ^a	16-Pin TSSOP	DG4051AEQ-T1-E3 DG4052AEQ-T1-E3 DG4053AEQ-T1-E3
	16-Pin miniQFN	DG4051AEN-T1-E4 DG4052AEN-T1-E4 DG4053AEN-T1-E4

Notes:

a. - 40 °C to 85 °C datasheet limits apply.



ABSOLUTE MAXIMUM RATINGS $T_A = 25\text{ }^\circ\text{C}$, unless otherwise noted			
Parameter	Limit	Unit	
V+ to V-	14	V	
GND to V-	7		
Digital Inputs ^a , V_S , V_D	(V-) - 0.3 to (V+) + 0.3 or 30 mA, whichever occurs first		
Continuous Current (Any terminal)	30	mA	
Peak Current, S or D (Pulsed 1 ms, 10 % duty cycle)	100		
Storage Temperature	- 65 to 150	$^\circ\text{C}$	
Power Dissipation ^b	16-Pin TSSOP ^c	450	mW
	16-Pin miniQFN ^{d, e}	525	
Thermal Resistance ^b	16-Pin TSSOP	178	$^\circ\text{C/W}$
	16-Pin miniQFN ^e	152	

Notes:

- a. Signals on SX, DX, or INX exceeding V+ or V- will be clamped by internal diodes. Limit forward diode current to maximum current ratings.
- b. All leads welded or soldered to PC board.
- c. Derate 5.6 mW/ $^\circ\text{C}$ above 70 $^\circ\text{C}$.
- d. Derate 6.6 mW/ $^\circ\text{C}$ above 70 $^\circ\text{C}$.
- e. Manual soldering with iron is not recommended for leadless components. The miniQFN-16 is a leadless package. The end of the lead terminal is exposed copper (not plated) as a result of the singulation process in manufacturing. A solder fillet at the exposed copper lip cannot be guaranteed and is not required to ensure adequate bottom side solder interconnection.

SPECIFICATIONS FOR DUAL SUPPLIES										
Parameter	Symbol	Test Conditions Unless Otherwise Specified $V_{CC} = +5\text{ V}$, $V_{EE} = -5\text{ V}$ $V_{IN(A, B, C \text{ and } ENABLE)} = 2.0\text{ V}$, 0.8 V^a	Temp. ^b	Typ. ^c	- 40 $^\circ\text{C}$ to 125 $^\circ\text{C}$		- 40 $^\circ\text{C}$ to 85 $^\circ\text{C}$		Unit	
					Min. ^d	Max. ^d	Min. ^d	Max. ^d		
Analog Switch										
Analog Signal Range ^e	V_{ANALOG}		Full		- 5	5	- 5	5	V	
On-Resistance	R_{ON}	$I_S = 1\text{ mA}$, $V_D = -3\text{ V}$, 0 V , $+3\text{ V}$	Room Full	66		100 125		100 118	Ω	
On-Resistance Match	ΔR_{ON}	$I_S = 1\text{ mA}$, $V_D = \pm 3\text{ V}$	Room Full	3		6 10		6 8		
On-Resistance Flatness	$R_{FLATNESS}$	$I_S = 1\text{ mA}$, $V_D = -3\text{ V}$, 0 V , $+3\text{ V}$	Room Full	12		16 20		16 18		
Switch Off Leakage Current	$I_{S(off)}$	$V_+ = 5.5\text{ V}$, $V_- = -5.5\text{ V}$, $V_D = \pm 4.5\text{ V}$, $V_S = \mp 4.5\text{ V}$	Room Full	± 0.02	- 1 - 50	1 50	- 1 - 5	1 5	nA	
	$I_{D(off)}$		Room Full	± 0.02	- 1 - 50	1 50	- 1 - 5	1 5		
Channel On Leakage Current	$I_{D(on)}$	$V_+ = 5.5\text{ V}$, $V_- = -5.5\text{ V}$, $V_S = V_D = \pm 4.5\text{ V}$	Room Full	± 0.02	- 1 - 50	1 50	- 1 - 5	1 5		
Digital Control										
Input Current, V_{IN} Low	I_{IL}	$V_{IN(A, B, C \text{ and } ENABLE)}$ under test = 0.8 V	Full	0.01	- 1	1	- 1	1	μA	
Input Current, V_{IN} High	I_{IH}	$V_{IN(A, B, C \text{ and } ENABLE)}$ under test = 2.0 V	Full	0.01	- 1	1	- 1	1		
Input Capacitance ^e	C_{IN}	$f = 1\text{ MHz}$	Room	3.4					pF	
Dynamic Characteristics										
Off Isolation	OIRR	$R_L = 50\ \Omega$, $C_L = 1\text{ pF}$		f = 10 MHz	Room	67				dB
				f = 100 MHz	Room	46				
Channel-to-Channel Crosstalk	X_{TALK}		f = 10 MHz	Room	67					
			f = 100 MHz	Room	47					
Bandwidth, 3 dB	BW	$R_L = 50\ \Omega$		DG4051A	Room	330				MHz
				DG4052A	Room	450				
				DG4053A	Room	730				

SPECIFICATIONS FOR DUAL SUPPLIES									
Parameter	Symbol	Test Conditions Unless Otherwise Specified $V_{CC} = +5\text{ V}$, $V_{EE} = -5\text{ V}$ $V_{IN(A, B, C \text{ and } ENABLE)} = 2.0\text{ V}$, 0.8 V^a	Temp. ^b	Typ. ^c	- 40 °C to 125 °C		- 40 °C to 85 °C		Unit
					Min. ^d	Max. ^d	Min. ^d	Max. ^d	
Dynamic Characteristics									
Transition Time	t_{TRANS}	$R_L = 300\ \Omega$, $C_L = 35\text{ pF}$ see figure 1, 2, 3	Room Full	36		110 127		110 117	ns
Enable Turn-On Time	t_{ON}		Room Full	31		108 119		108 114	
Enable Turn-Off Time	t_{OFF}		Room Full	29		92 103		92 98	
Break-Before-Make Time Delay	t_D		Room Full		1		1		
Charge Injection ^e	Q	$V_g = 0\text{ V}$, $R_g = 0\ \Omega$, $C_L = 1\text{ nF}$	Room	0.25					pC
Off Isolation ^e	OIRR	$R_L = 50\ \Omega$, $C_L = 1\text{ pF}$ $f = 100\text{ kHz}$	Room	< - 90					dB
Channel-to-Channel Crosstalk ^e	X_{TALK}		Room	< - 90					
Source Off Capacitance ^e	$C_{S(off)}$	$f = 1\text{ MHz}$	DG4051A	Room	3				pF
			DG4052A	Room	3				
			DG4053A	Room	3				
Drain Off Capacitance ^e	$C_{D(off)}$	$f = 1\text{ MHz}$	DG4051A	Room	12				
			DG4052A	Room	7				
			DG4053A	Room	4				
Channel On Capacitance ^e	$C_{D(on)}$	$f = 1\text{ MHz}$	DG4051A	Room	17				
			DG4052A	Room	13				
			DG4053A	Room	11				
Total Harmonic Distortion ^e	THD	Signal = 5 V_{RMS} , 20 Hz to 20 kHz, $R_L = 600\ \Omega$	Room	0.28					%
Power Supplies									
Power Supply Current	I+	$V_{CC} = +5\text{ V}$, $V_{EE} = -5\text{ V}$ $V_{IN(A, B, C \text{ and } ENABLE)} = 0\text{ or }5\text{ V}$	Room Full	0.05		1 10		1 10	μA
Negative Supply Current	I-		Room Full	- 0.05	- 1 - 10		- 1 - 10		
Ground Current	I_{GND}		Room Full	- 0.05	- 1 - 10		- 1 - 10		



SPECIFICATIONS FOR UNIPOLAR SUPPLIES									
Parameter	Symbol	Test Conditions Unless Otherwise Specified $V_{CC} = +5\text{ V}$, $V_{EE} = 0\text{ V}$ $V_{IN(A, B, C \text{ and } ENABLE)} = 2.0\text{ V}$, 0.8 V^a	Temp. ^b	Typ. ^c	- 40 °C to 125 °C		- 40 °C to 85 °C		Unit
					Min. ^d	Max. ^d	Min. ^d	Max. ^d	
Analog Switch									
Analog Signal Range ^e	V_{ANALOG}		Full		0	5	0	5	V
On-Resistance	R_{ON}	$I_S = 1\text{ mA}$, $V_D = 0\text{ V}$, $+3.5\text{ V}$	Room Full	107		165 205		165 194	Ω
On-Resistance Match	ΔR_{ON}	$I_S = 1\text{ mA}$, $V_D = +3.5\text{ V}$	Room Full	3.2		8 13		8 11	
On-Resistance Flatness	$R_{FLATNESS}$	$I_S = 1\text{ mA}$, $V_D = 0\text{ V}$, $+3\text{ V}$	Room Full	19		26 30		26 28	
Switch Off Leakage Current	$I_{S(off)}$	$V_+ = +5.5\text{ V}$, $V_- = 0\text{ V}$ $V_D = 1\text{ V}/4.5\text{ V}$, $V_S = 4.5\text{ V}/1\text{ V}$	Room Full	± 0.02	- 1 - 50	1 50	- 1 - 5	1 5	nA
	$I_{D(off)}$		Room Full	± 0.02	- 1 - 50	1 50	- 1 - 5	1 5	
Channel On Leakage Current	$I_{D(on)}$	$V_+ = +5.5\text{ V}$, $V_- = 0\text{ V}$ $V_D = V_S = 1\text{ V}/4.5\text{ V}$	Room Full	± 0.02	- 1 - 50	1 50	- 1 - 5	1 5	
Digital Control									
Input Current, V_{IN} Low	I_L	$V_{IN(A, B, C \text{ and } ENABLE)}$ under test = 0.8 V	Full	0.01	- 1	1	- 1	1	μA
Input Current, V_{IN} High	I_H	$V_{IN(A, B, C \text{ and } ENABLE)}$ under test = 2.0 V	Full	0.01	- 1	1	- 1	1	
Dynamic Characteristics									
Transition Time	t_{TRANS}	$R_L = 300\ \Omega$, $C_L = 35\text{ pF}$ See Figure 1, 2, 3	Room Full	38		121 143		121 134	ns
Enable Turn-On Time	t_{ON}		Room Full	38		110 126		110 119	
Enable Turn-Off Time	t_{OFF}		Room Full	38		103 118		103 111	
Break-Before-Make Time Delay	t_D		Room Full		1		1		
Charge Injection ^e	Q	$V_g = 0\text{ V}$, $R_g = 0\ \Omega$, $C_L = 1\text{ nF}$	Full	0.5					pC
Off Isolation ^e	OIRR	$R_L = 50\ \Omega$, $C_L = 1\text{ pF}$ $f = 100\text{ kHz}$	Room	< - 90					dB
Channel-to-Channel Crosstalk ^e	X_{TALK}		Room	< - 90					
Source Off Capacitance ^e	$C_{S(off)}$	$f = 1\text{ MHz}$	DG4051A	Room	3				pF
			DG4052A	Room	3				
			DG4053A	Room	4				
Drain Off Capacitance ^e	$C_{D(off)}$	$f = 1\text{ MHz}$	DG4051A	Room	13				
			DG4052A	Room	8				
			DG4053A	Room	5				
Channel On Capacitance ^e	$C_{D(on)}$	$f = 1\text{ MHz}$	DG4051A	Room	18				
			DG4052A	Room	14				
			DG4053A	Room	11				
Power Supplies									
Power Supply Current	I_+	$V_{IN(A, B, C \text{ and } ENABLE)} = 0\text{ V}$ or 5 V	Room Full	0.05		1 10		1 10	μA
Negative Supply Current	I_-		Room Full	- 0.05	- 1 - 10		- 1 - 10		
Ground Current	I_{GND}		Room Full	- 0.05	- 1 - 10		- 1 - 10		

SPECIFICATIONS FOR UNIPOLAR SUPPLIES										
Parameter	Symbol	Test Conditions Unless Otherwise Specified $V_{CC} = +3\text{ V}$, $V_{EE} = 0\text{ V}$ $V_{IN(A, B, C \text{ and } ENABLE)} = 1.4\text{ V}$, 0.6 V^a		Temp. ^b	Typ. ^c	- 40 °C to 125 °C		- 40 °C to 85 °C		Unit
						Min. ^d	Max. ^d	Min. ^d	Max. ^d	
Analog Switch										
Analog Signal Range ^e	V_{ANALOG}		Full		0	3	0	3	V	
On-Resistance	R_{ON}	$I_S = 1\text{ mA}$, $V_D = 1.5\text{ V}$	Room Full	175		265 310		265 298	Ω	
Switch Off Leakage Current	$I_{S(off)}$	$V_+ = +3.3\text{ V}$, $V_- = 0\text{ V}$ $V_D = 0.3\text{ V}/3.0\text{ V}$, $V_S = 3.0\text{ V}/0.3\text{ V}$	Room Full	± 0.02	- 1 - 50	1 50	- 1 - 5	1 5	nA	
	$I_{D(off)}$		Room Full	± 0.02	- 1 - 50	1 50	- 1 - 5	1 5		
Channel On Leakage Current	$I_{D(on)}$	$V_+ = +3.3\text{ V}$, $V_- = 0\text{ V}$ $V_D = V_S = 0.3\text{ V}/3.0\text{ V}$	Room Full	± 0.02	- 1 - 50	1 50	- 1 - 5	1 5		
Digital Control										
Input Current, V_{IN} Low	I_L	$V_{IN(A, B, C \text{ and } ENABLE)}$ under test = 0.6 V	Full	0.01	- 1	1	- 1	1	μA	
Input Current, V_{IN} High	I_H	$V_{IN(A, B, C \text{ and } ENABLE)}$ under test = 1.4 V	Full	0.01	- 1	1	- 1	1		
Dynamic Characteristics										
Transition Time	t_{TRANS}	$R_L = 300\ \Omega$, $C_L = 35\text{ pF}$ see figure 1, 2, 3	Room Full	81		172 218		172 194	ns	
Enable Turn-On Time	t_{ON}		Room Full	71		151 183		151 167		
Enable Turn-Off Time	t_{OFF}		Room Full	69		138 161		138 151		
Break-Before-Make Time Delay	t_D		Room Full		1		1			
Charge Injection ^e	Q	$V_g = 0\text{ V}$, $R_g = 0\ \Omega$, $C_L = 1\text{ nF}$	Room	0.5					pC	
Off Isolation ^e	OIRR	$R_L = 50\ \Omega$, $C_L = 1\text{ pF}$ $f = 100\text{ kHz}$	Room	< - 90					dB	
Channel-to-Channel Crosstalk ^e	X_{TALK}		Room	< - 90						
Source Off Capacitance ^e	$C_{S(off)}$	$f = 1\text{ MHz}$	DG4051A	Room	4				pF	
			DG4052A	Room	3					
			DG4053A	Room	4					
Drain Off Capacitance ^e	$C_{D(off)}$	$f = 1\text{ MHz}$	DG4051A	Room	14					
			DG4052A	Room	8					
			DG4053A	Room	5					
Channel On Capacitance ^e	$C_{D(on)}$	$f = 1\text{ MHz}$	DG4051A	Room	19					
			DG4052A	Room	14					
			DG4053A	Room	11					
Power Supplies										
Power Supply Current	I_+	$V_{IN(A, B, C \text{ and } ENABLE)} = 0\text{ V}$ or 3 V	Room Full	0.05		1 10		1 10	μA	
Negative Supply Current	I_-		Room Full	- 0.05	- 1 - 10		- 1 - 10			
Ground Current	I_{GND}		Room Full	- 0.05	- 1 - 10		- 1 - 10			

Notes:

- a. V_{IN} = input voltage to perform proper function.
- b. Room = 25 °C, Full = as determined by the operating temperature suffix.
- c. Typical values are for DESIGN AID ONLY, not guaranteed nor subject to production testing.
- d. The algebraic convention whereby the most negative value is a minimum and the most positive a maximum, is used in this data sheet.
- e. Guaranteed by design, not subject to production test.

Stresses beyond those listed under "Absolute Maximum Ratings" may cause permanent damage to the device. These are stress ratings only, and functional operation of the device at these or any other conditions beyond those indicated in the operational sections of the specifications is not implied. Exposure to absolute maximum rating conditions for extended periods may affect device reliability.

TYPICAL CHARACTERISTICS 25 °C, unless otherwise noted

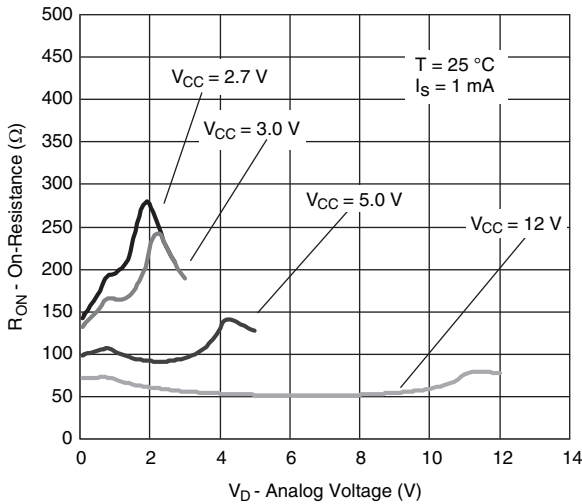

On-Resistance vs. V_D and Single Supply Voltage

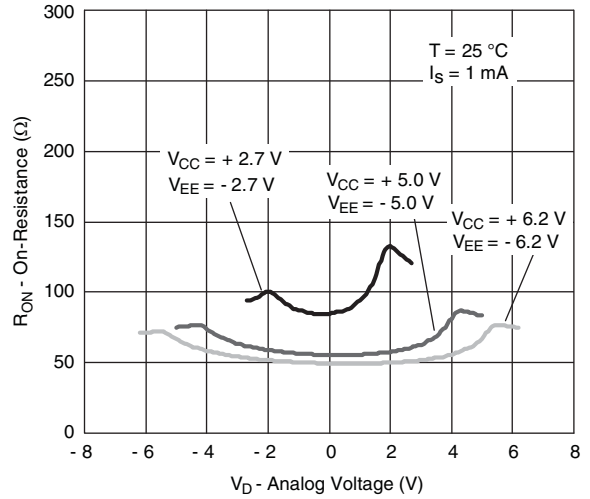

On-Resistance vs. V_D and Dual Supply Voltage

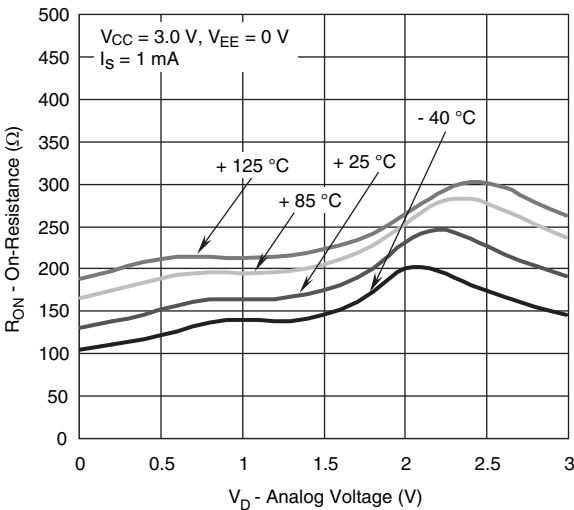

On-Resistance vs. Analog Voltage and Temperature at $V_{CC} = +3\text{ V}$, $V_{EE} = 0\text{ V}$

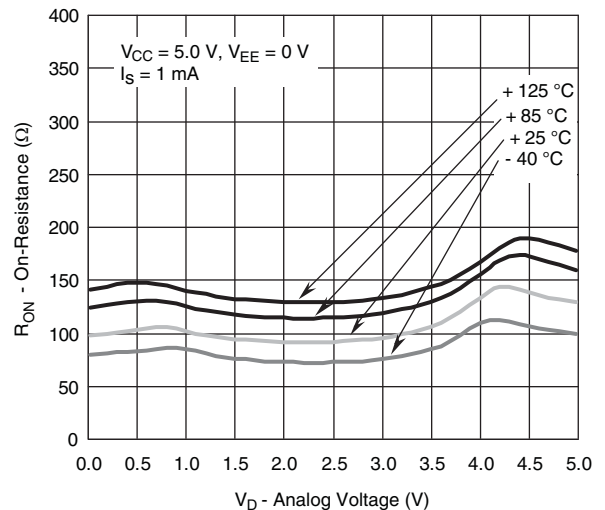

On-Resistance vs. Analog Voltage and Temperature at $V_{CC} = +5\text{ V}$, $V_{EE} = 0\text{ V}$

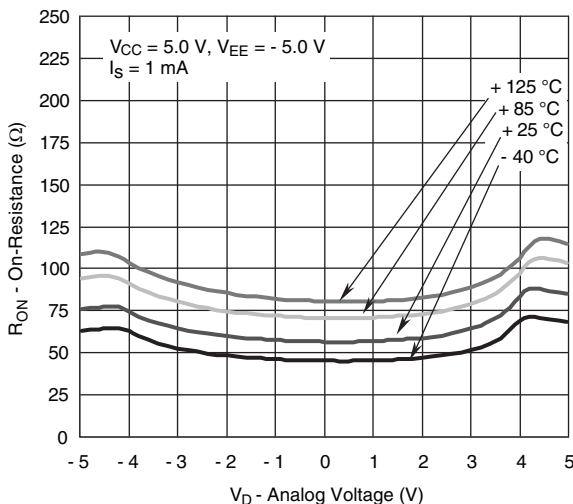

On-Resistance vs. Analog Voltage and Temperature at $V_{CC} = +5\text{ V}$, $V_{EE} = -5\text{ V}$

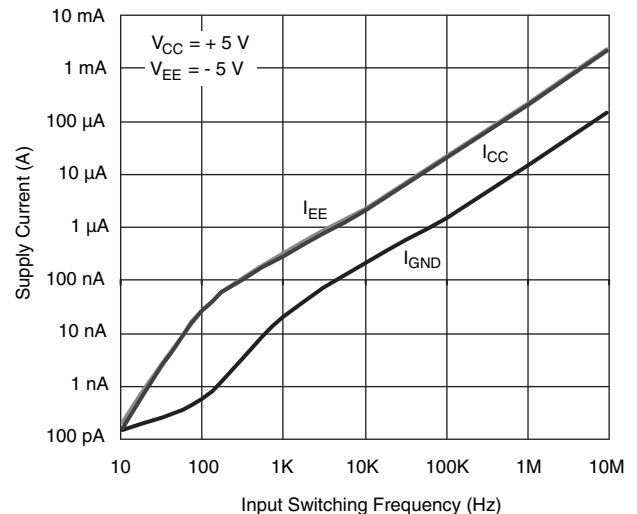

Supply Current vs. Input Switching Frequency

TYPICAL CHARACTERISTICS 25 °C, unless otherwise noted

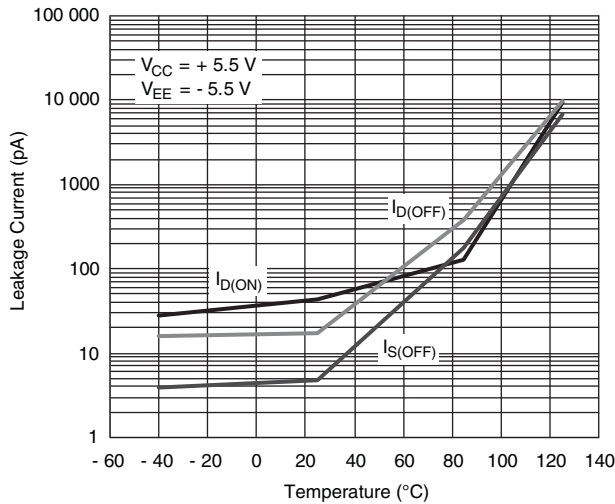

Leakage Current vs. Temperature

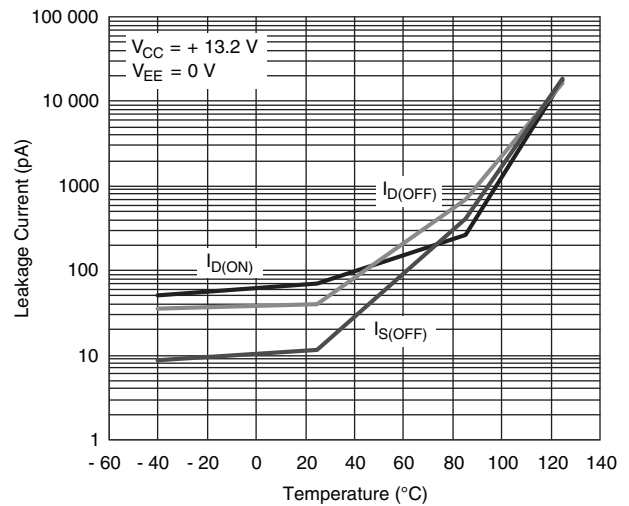

Leakage Current vs. Temperature

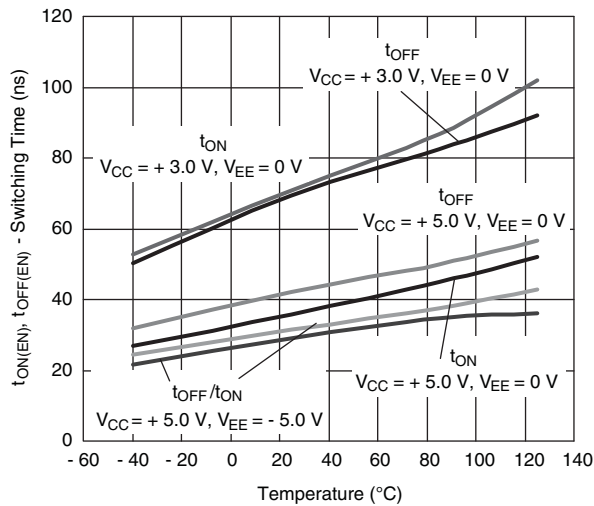

Switching Time vs. Temperature

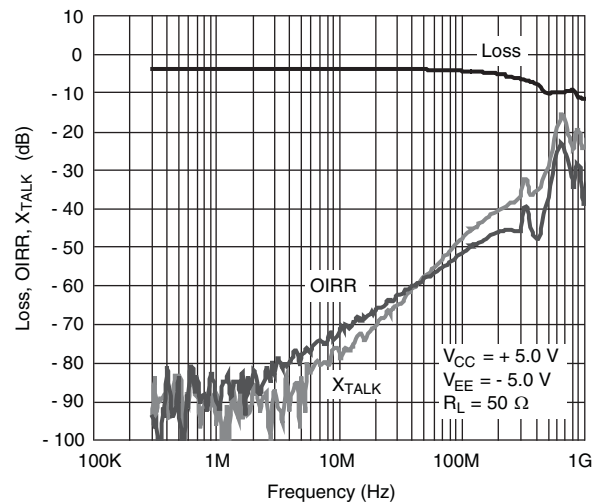

DG4051A Insertion Loss, Off-Isolation, Crosstalk vs. Frequency at ± 5 V Supply

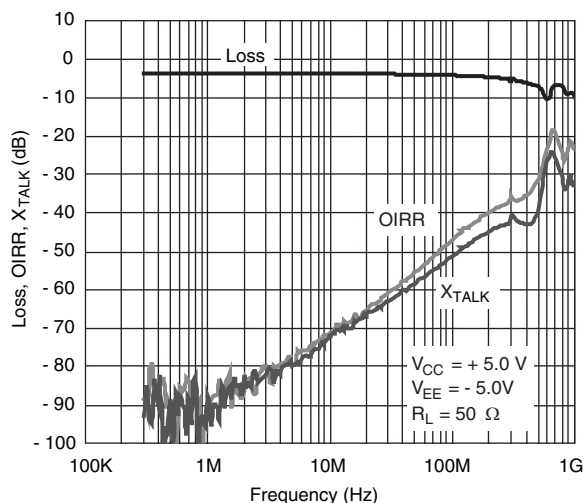

DG4052A Insertion Loss, Off-Isolation, Crosstalk vs. Frequency at ± 5 V Supply

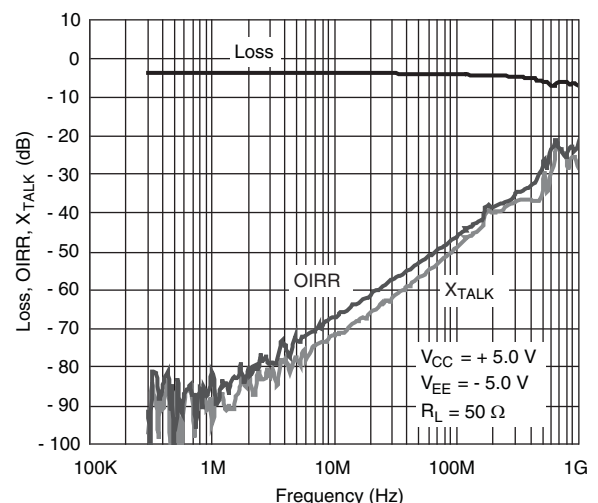

DG4053A Insertion Loss, Off-Isolation, Crosstalk vs. Frequency at ± 5 V Supply

TYPICAL CHARACTERISTICS 25 °C, unless otherwise noted

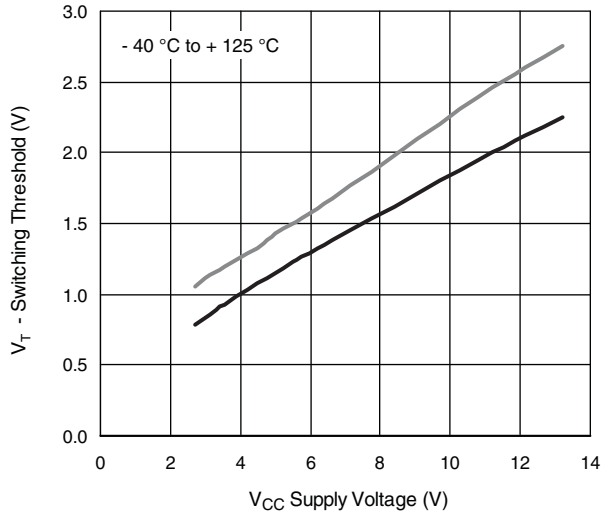

Switching Threshold vs. V_{CC} Supply Voltage

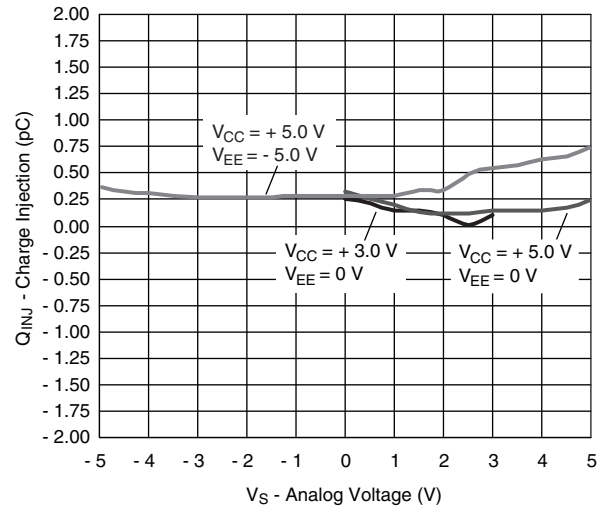

DG4051A Charge Injection vs. Analog Voltage

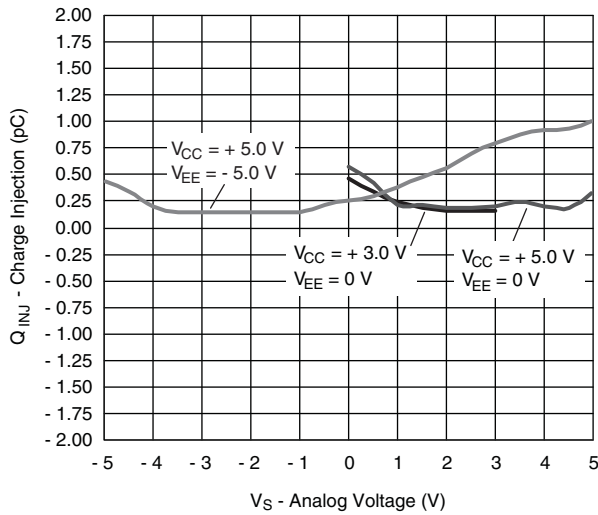

DG4052A Charge Injection vs. Analog Voltage

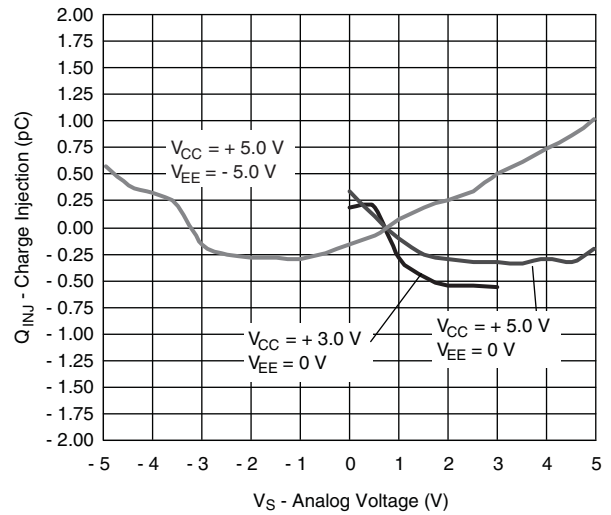

DG4053A Charge Injection vs. Analog Voltage

TEST CIRCUITS

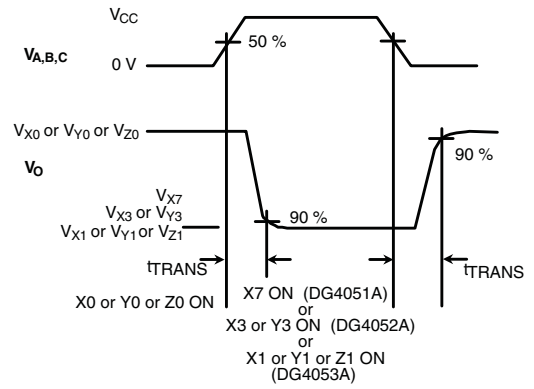
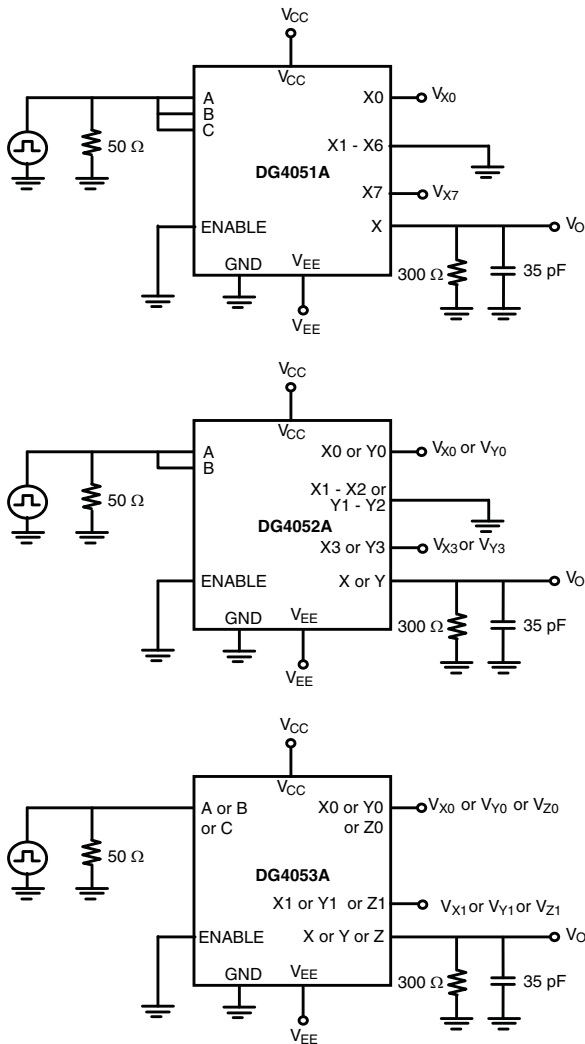

Figure 1. Transition Time

TEST CIRCUITS

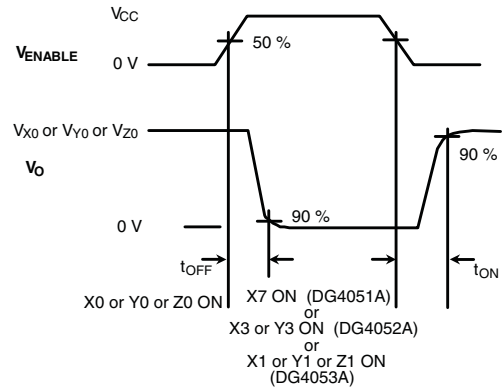
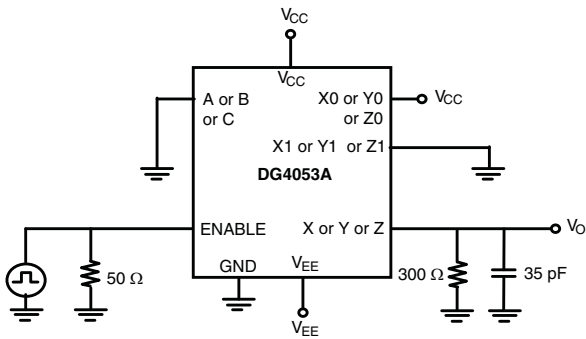
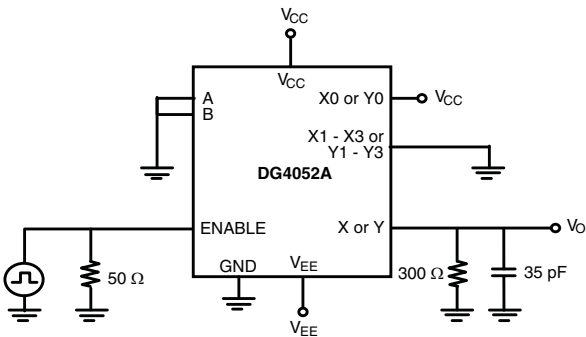
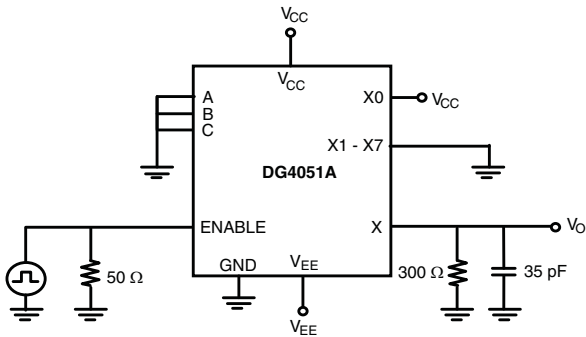

Figure 2. Enable Switching Time

TEST CIRCUITS

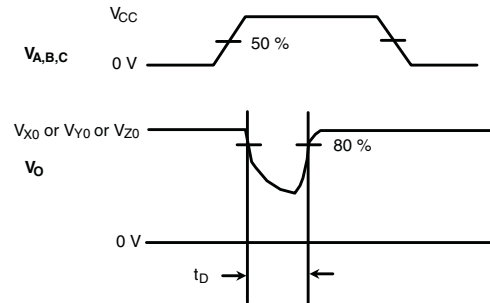
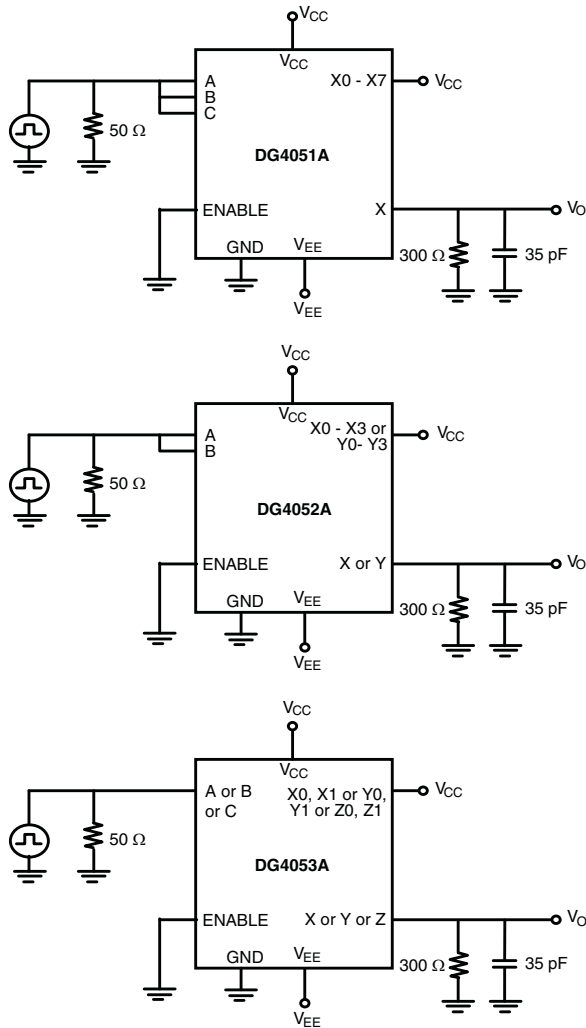

Figure 3. Break-Before-Make

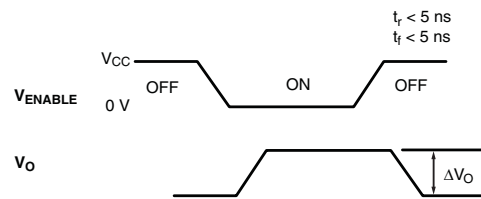
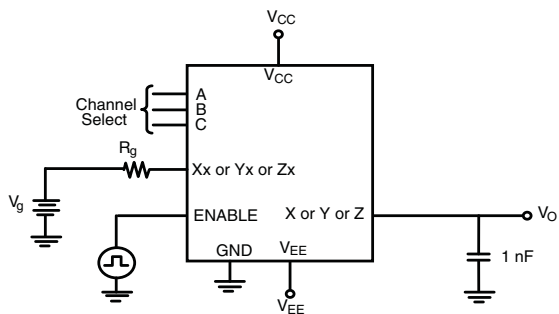
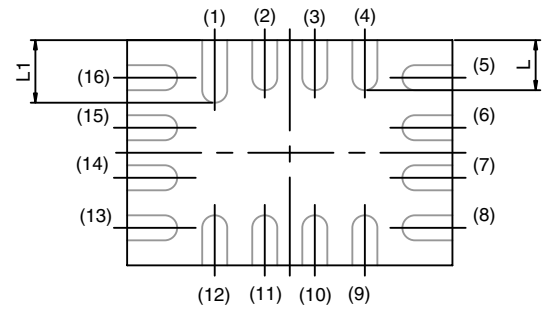
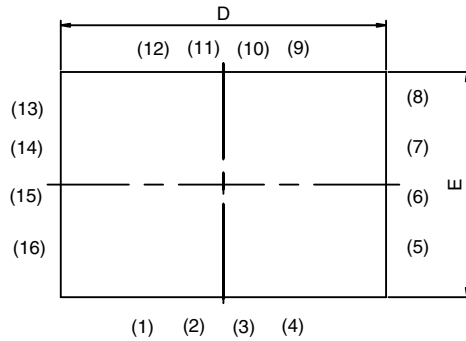
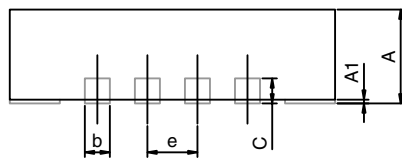

Figure 4. Charge Injection

MINI QFN-16L



BACK SIDE VIEW



DIM	MILLIMETERS			INCHES		
	MIN.	NAM	MAX.	MIN.	NAM	MAX.
A	0.70	0.75	0.80	0.0275	0.0295	0.0315
A1	0	-	0.05	0	-	0.002
b	0.15	0.20	0.25	0.0059	0.0078	0.0098
C	0.15	0.20	0.25	0.0059	0.0078	0.0098
D	2.60 BSC			0.1023 BSC		
E	1.80 BSC			0.0708 BSC		
e	0.40 BSC			0.0157 BSC		
L	0.35	0.40	0.45	0.0137	0.0157	0.0177
L1	0.45	0.50	0.55	0.0177	0.0196	0.0216

ECN T-06380-Rev. A, 14-Aug-06
DWG: 5954

TSSOP: 16-LEAD

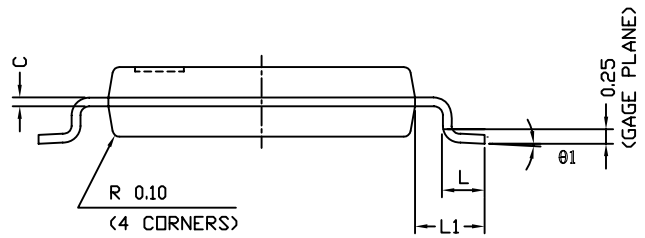
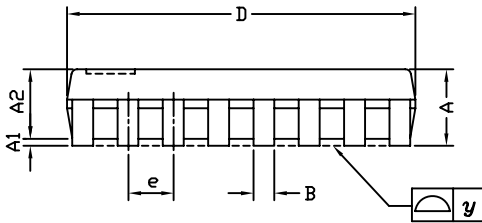
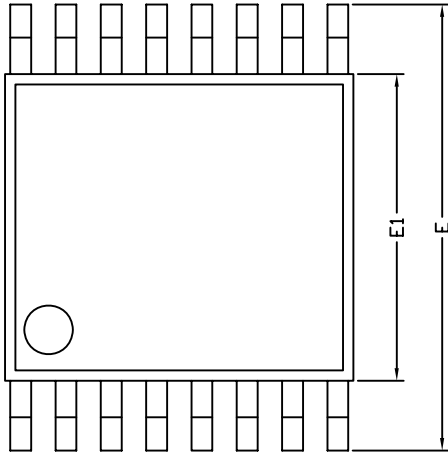

Symbols	DIMENSIONS IN MILLIMETERS		
	Min	Nom	Max
A	-	1.10	1.20
A1	0.05	0.10	0.15
A2	-	1.00	1.05
B	0.22	0.28	0.38
C	-	0.127	-
D	4.90	5.00	5.10
E	6.10	6.40	6.70
E1	4.30	4.40	4.50
e	-	0.65	-
L	0.50	0.60	0.70
L1	0.90	1.00	1.10
y	-	-	0.10
$\theta 1$	0°	3°	6°

ECN: S-61920-Rev. D, 23-Oct-06
DWG: 5624



RECOMMENDED MINIMUM PAD FOR TSSOP-16

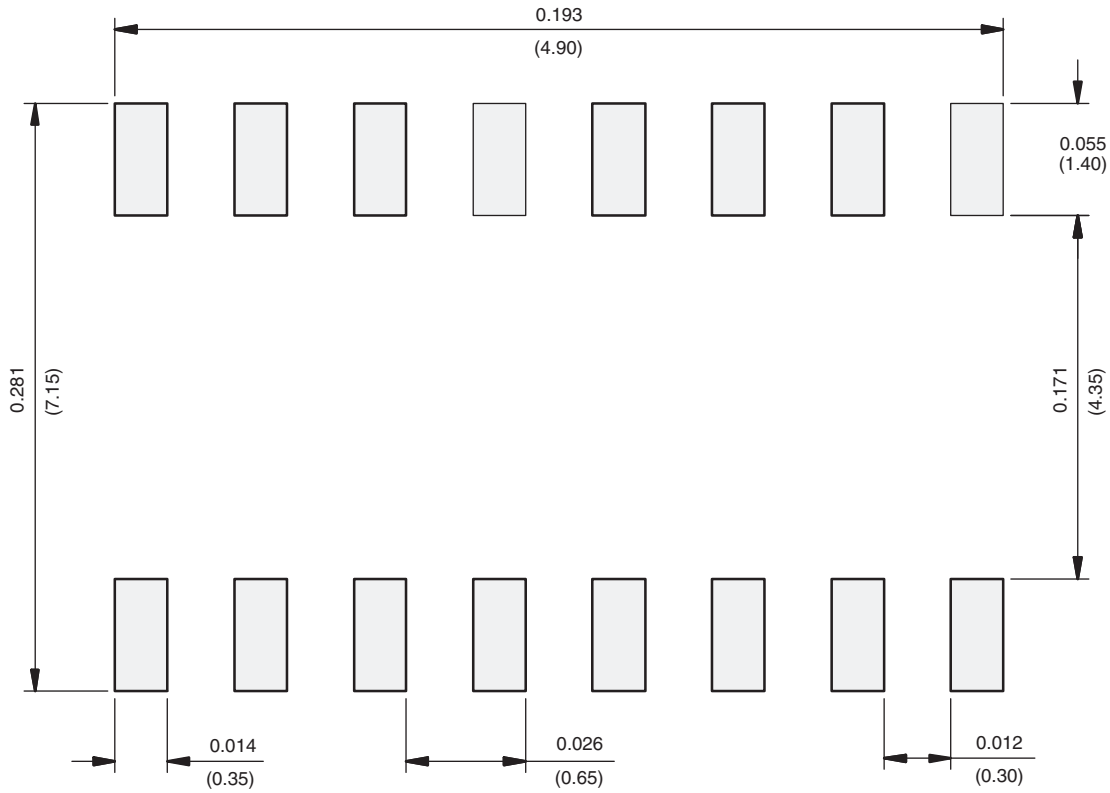

Recommended Minimum Pads
Dimensions in inches (mm)



Disclaimer

ALL PRODUCT, PRODUCT SPECIFICATIONS AND DATA ARE SUBJECT TO CHANGE WITHOUT NOTICE TO IMPROVE RELIABILITY, FUNCTION OR DESIGN OR OTHERWISE.

Vishay Intertechnology, Inc., its affiliates, agents, and employees, and all persons acting on its or their behalf (collectively, "Vishay"), disclaim any and all liability for any errors, inaccuracies or incompleteness contained in any datasheet or in any other disclosure relating to any product.

Vishay makes no warranty, representation or guarantee regarding the suitability of the products for any particular purpose or the continuing production of any product. To the maximum extent permitted by applicable law, Vishay disclaims (i) any and all liability arising out of the application or use of any product, (ii) any and all liability, including without limitation special, consequential or incidental damages, and (iii) any and all implied warranties, including warranties of fitness for particular purpose, non-infringement and merchantability.

Statements regarding the suitability of products for certain types of applications are based on Vishay's knowledge of typical requirements that are often placed on Vishay products in generic applications. Such statements are not binding statements about the suitability of products for a particular application. It is the customer's responsibility to validate that a particular product with the properties described in the product specification is suitable for use in a particular application. Parameters provided in datasheets and/or specifications may vary in different applications and performance may vary over time. All operating parameters, including typical parameters, must be validated for each customer application by the customer's technical experts. Product specifications do not expand or otherwise modify Vishay's terms and conditions of purchase, including but not limited to the warranty expressed therein.

Except as expressly indicated in writing, Vishay products are not designed for use in medical, life-saving, or life-sustaining applications or for any other application in which the failure of the Vishay product could result in personal injury or death. Customers using or selling Vishay products not expressly indicated for use in such applications do so at their own risk. Please contact authorized Vishay personnel to obtain written terms and conditions regarding products designed for such applications.

No license, express or implied, by estoppel or otherwise, to any intellectual property rights is granted by this document or by any conduct of Vishay. Product names and markings noted herein may be trademarks of their respective owners.

Material Category Policy

Vishay Intertechnology, Inc. hereby certifies that all its products that are identified as RoHS-Compliant fulfill the definitions and restrictions defined under Directive 2011/65/EU of The European Parliament and of the Council of June 8, 2011 on the restriction of the use of certain hazardous substances in electrical and electronic equipment (EEE) - recast, unless otherwise specified as non-compliant.

Please note that some Vishay documentation may still make reference to RoHS Directive 2002/95/EC. We confirm that all the products identified as being compliant to Directive 2002/95/EC conform to Directive 2011/65/EU.

Vishay Intertechnology, Inc. hereby certifies that all its products that are identified as Halogen-Free follow Halogen-Free requirements as per JEDEC JS709A standards. Please note that some Vishay documentation may still make reference to the IEC 61249-2-21 definition. We confirm that all the products identified as being compliant to IEC 61249-2-21 conform to JEDEC JS709A standards.