

DF3 Series

2mm Pitch Connector for Discrete Wire Connection (Product approved by UL CSA Standard)

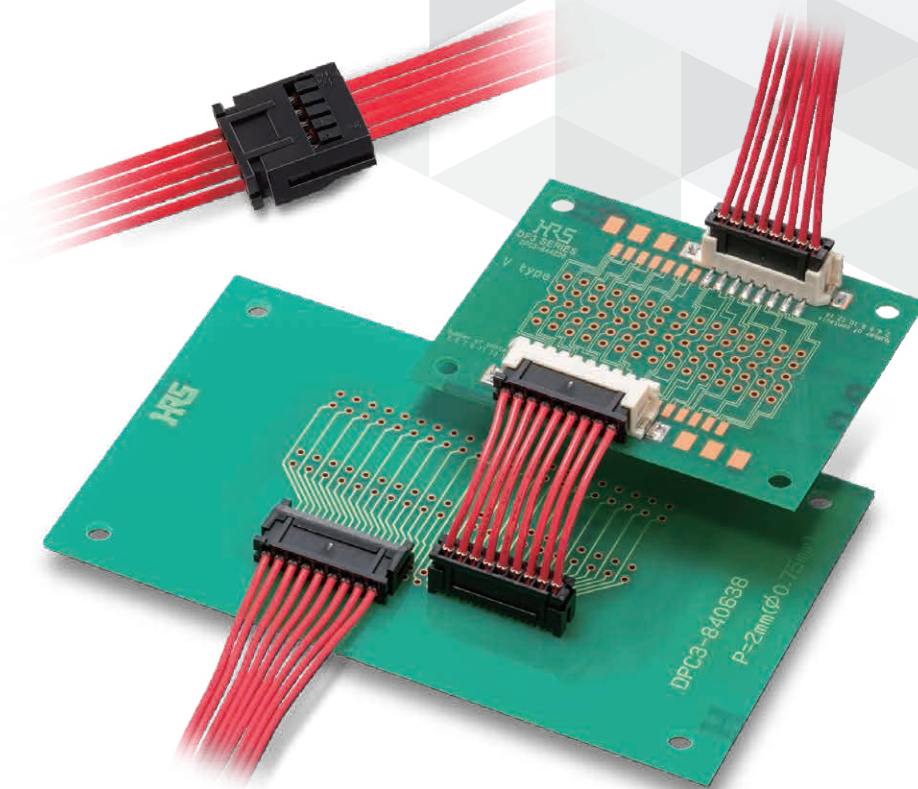

Aug. 1.2024 Copyright 2024 HIROSE ELECTRIC CO., LTD. All Rights Reserved.

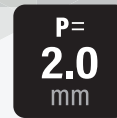

Features

1. Correspond to Board Design in Wide Variation

- Crimp Socket

- (1) Low profile design with mounting height 7.5mm. (See the application chart.)
- (2) Provide the contact crimping area with the sufficient space, and secures the stable crimping operation.

- Pin Header

- (1) The board pre-fixed kink is treated with the post pin.
- (2) The shape is a box type that is resistant to wrenching.
- (3) The type corresponding to SMT is available, using the heat-resistant resin. This SMT header is equipped with the retention tab to prevent peeling in the solder joint area.

- In-Line Plug

There are two types of crimp in-line plugs: a type designed for space merit and a panel lock type that can be fixed to a panel.

2. UL, CSA Certified

Application

General office automation equipment such as copiers and printers

Product Specifications

Rated Current (Note1)	Crimping	22 to 24AWG	26 AWG	28 AWG	Operating Temperature (Note 2)	-55 to +105°C
		3A / pin	2A / pin	1A / pin	Operating Humidity Range (Note 3)	40 to 80%
Rated Voltage	250V AC/DC			Storage Temperature Range (Note 4)		-10 to +60°C
				Storage Humidity Range (Note 4)		40 to 70%

UL-CSA	Rated Current	24 AWG	26AWG	28 AWG
		3A / pin	2A / pin (Note 5)	1A / pin
	Rated Voltage	30V AC/DC		

UL, CSA File No.
UL : E52653
CSA : LR95109

Item	Standards	Condition
Insulation Resistance	1,000M Ω Min.	Measured at 500V DC
Withstanding Voltage	No flashover or dielectric breakdown	650V AC for 1 min.
Contact Resistance	30m Ω Max.	Measured at 20mV Max., 1mA
Vibration Resistance	No electrical discontinuity of 1 μ s or more	Frequency 10 to 55 Hz, Half amplitude 0.75 mm, 2 hours in each of the 3 directions
Humidity Resistance	Contact Resistance : 30m Ω Max. Insulation Resistance: 500M Ω Min.	96 hours at temperature of +40 \pm 2°C and humidity of 90 to 95%
Temperature Cycle	Contact Resistance : 30m Ω Max. Insulation Resistance: 1,000M Ω Min.	-55°C : 30 minutes \rightarrow +5 to +35°C : 2 to 3 minutes \rightarrow +85°C : 30 minutes \rightarrow +5 to +35°C : 2 to 3 minutes, 5 cycles
Mating Durability	Contact Resistance: 30m Ω Max.	Tin Plating : 30 times Gold Plating : 50 times
Solder Heat Resistance	No dissolution of the resin part affecting performance.	Dip Type Flow : +260°C , 10sec. / Hand Soldering : Soldering iron temperature +300°C , for 2 sec. SMT Type Reflow : Recommended in Temperature Profile / Hand Soldering : Soldering iron temperature 300°C for 3sec.

Note 1: Information contained in this catalog represents general requirements for this Series.

Contact us for the drawings and specifications for a specific part number shown.

Note 2 : Includes temperature rise caused by current flow.

Note 3 : Use without condensation.

Note 4 : Apply to unused product on packaged condition.

Note 5 : The mating side is a crimp type.

Note 6 : Information contained in this catalog represents general requirements for this Series.

Contact us for the drawings and specifications for a specific part number shown.

Materials / Finish

Item	Component	Material	Finish	UL Flame Retardant Grade	RoHS
Crimp Socket	Insulator	PA	Black	UL94V-0	○
Crimp Contact for Socket	Contact	Phosphorous Bronze	Tin Plating or Gold Plating	-	
Pin Header	Insulator	PA	Black	UL94V-0	
	Contact	Brass	Tin Plating or Gold Plating	-	
SMT Pin Header	Insulator	PA	Beige	UL94V-0	
	Contact	Brass	Tin Plating or Gold Plating	-	
	Retention Tab	Brass	Tin Plating	-	
In-Line Plug	Insulator	PA	Black	UL94V-0	
In-Line Plug Crimp Contact	Contact	Phosphorous Bronze	Tin Plating or Gold Plating	-	

Product Number Structure

Refer to the chart below when determining the product specifications from the product number. Please select from the product numbers listed in this catalog when placing orders.

● Connector

DF3 - # S - 2 C

① ② ③ ④ ⑤

① Series Name	DF3, 3A, 3AA, 3EA	④ Contact Pitch	2mm
② No. of Pos.	2, 3, 4, 5, 6, 7, 8, 9, 10, 11, 12, 13, 14, 15	⑤ Termination Type / Contact Type	C : Crimp Housing DSA : Straight Dip DS : Right Angle Dip V : Straight SMT H : Right Angle SMT
③ Connector Type	S : Socket P : Pin Header EP : In-Line Plug		

● Contact

DF3 - EP 2428 PCF A

① ② ③ ④

① Terminal Type	EP : In-Line	④ Plating Type	None : Tin Plating A : Gold Plating (Plug Contact) C : Gold Plating (Socket Contact)
② Applicable Wire Size	22 : 22AWG 2428 : 24 to 28AWG		
③ Termination Type / Contact Type	SCF : Socket Contact / Reel SC : Socket Contact / Loose Piece PCF : Plug Contact / Reel PC : Plug Contact / Loose Piece		

Connector Mating Combinations Diagram

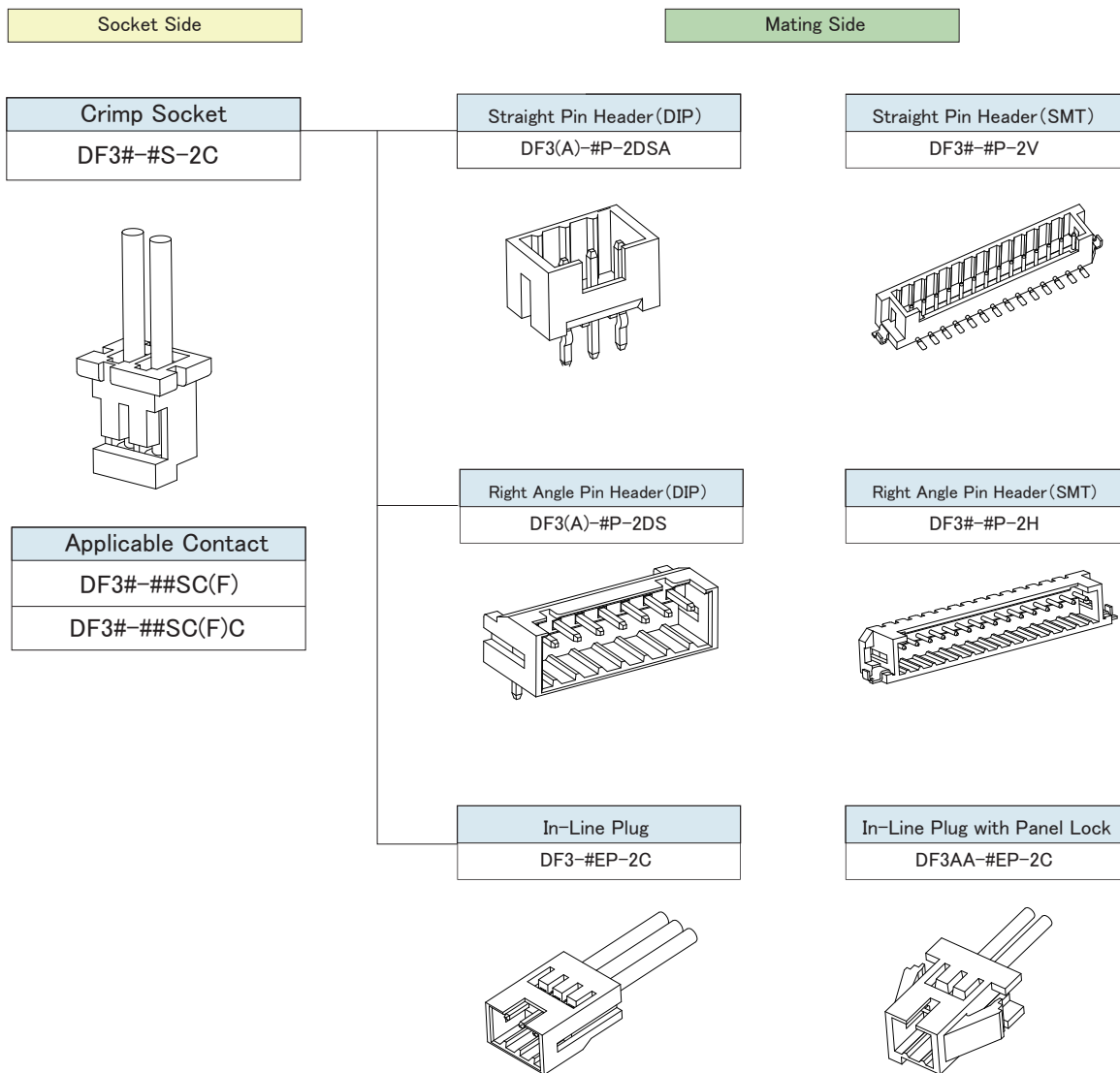

Aug. 1.2024 Copyright 2024 HIROSE ELECTRIC CO., LTD. All Rights Reserved.

Crimp Socket

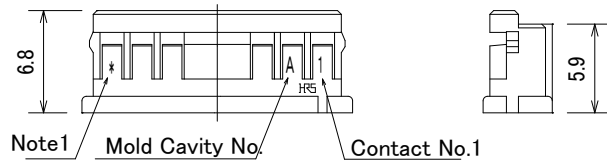
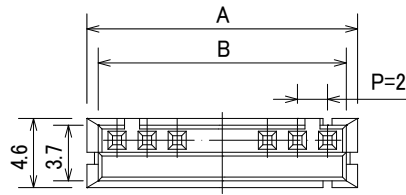

Unit : mm

Part No.	HRS No.	No. of Pos.	A	B	Purchase Unit
DF3-2S-2C	CL0543-0003-8-00	2	6	2	100pcs per bag
DF3-3S-2C	CL0543-0004-0-00	3	8	4	
DF3-4S-2C	CL0543-0005-3-00	4	10	6	
DF3-5S-2C	CL0543-0006-6-00	5	12	8	
DF3-6S-2C	CL0543-0007-9-00	6	14	10	
DF3-7S-2C	CL0543-0008-1-00	7	16	12	
DF3-8S-2C	CL0543-0009-4-00	8	18	14	
DF3-9S-2C	CL0543-0010-3-00	9	20	16	
DF3-10S-2C	CL0543-0011-6-00	10	22	18	
DF3-11S-2C	CL0543-0012-9-00	11	24	20	
DF3-12S-2C	CL0543-0013-1-00	12	26	22	
DF3-13S-2C	CL0543-0014-4-00	13	28	24	
DF3-14S-2C	CL0543-0015-7-00	14	30	26	
DF3-15S-2C	CL0543-0016-0-00	15	32	28	

Note 1 : Show the number of product pos..

Straight Pin Header

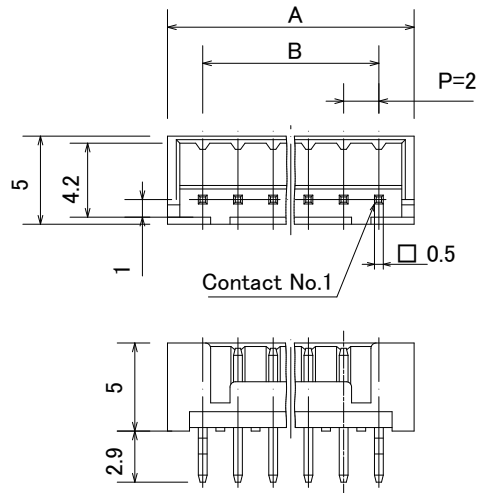
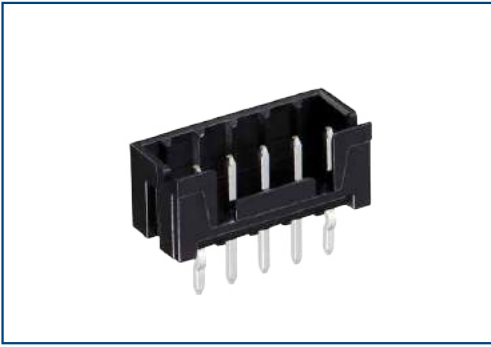

·Board Through-Hole Diameter : $\phi 0.8^{+0.1}_0$
 ·Kink Pre-Fixed Effective Diameter : $\phi 0.8^{+0.05}_0$

● Tin Plating

Unit : mm

Part No.	HRS No.	No. of Pos.	A	B	Purchase Unit
DF3A-2P-2DSA	CL0543-0165-0-00	2	6	2	100pcs per bag
DF3A-3P-2DSA	CL0543-0166-2-00	3	8	4	
DF3A-4P-2DSA	CL0543-0167-5-00	4	10	6	
DF3A-5P-2DSA	CL0543-0168-8-00	5	12	8	
DF3A-6P-2DSA	CL0543-0169-0-00	6	14	10	
DF3A-7P-2DSA	CL0543-0170-0-00	7	16	12	
DF3A-8P-2DSA	CL0543-0171-2-00	8	18	14	
DF3A-9P-2DSA	CL0543-0172-5-00	9	20	16	
DF3A-10P-2DSA	CL0543-0173-8-00	10	22	18	
DF3A-11P-2DSA	CL0543-0174-0-00	11	24	20	
DF3A-12P-2DSA	CL0543-0175-3-00	12	26	22	
DF3A-13P-2DSA	CL0543-0176-6-00	13	28	24	
DF3A-14P-2DSA	CL0543-0177-9-00	14	30	26	
DF3A-15P-2DSA	CL0543-0178-1-00	15	32	28	

● Gold Plating

Unit : mm

Part No.	HRS No.	No. of Pos.	A	B	Purchase Unit
DF3-2P-2DSA(01)	CL0543-0017-2-01	2	6	2	100pcs per bag
DF3-3P-2DSA(01)	CL0543-0018-5-01	3	8	4	
DF3-4P-2DSA(01)	CL0543-0019-8-01	4	10	6	
DF3-5P-2DSA(01)	CL0543-0020-7-01	5	12	8	
DF3-6P-2DSA(01)	CL0543-0021-0-01	6	14	10	
DF3-7P-2DSA(01)	CL0543-0022-2-01	7	16	12	
DF3-8P-2DSA(01)	CL0543-0023-5-01	8	18	14	
DF3-9P-2DSA(01)	CL0543-0024-8-01	9	20	16	
DF3-10P-2DSA(01)	CL0543-0025-0-01	10	22	18	
DF3-11P-2DSA(01)	CL0543-0026-3-01	11	24	20	
DF3-12P-2DSA(01)	CL0543-0027-6-01	12	26	22	
DF3-13P-2DSA(01)	CL0543-0028-9-01	13	28	24	
DF3-14P-2DSA(01)	CL0543-0029-1-01	14	30	26	
DF3-15P-2DSA(01)	CL0543-0030-0-01	15	32	28	

Right Angle Pin Header

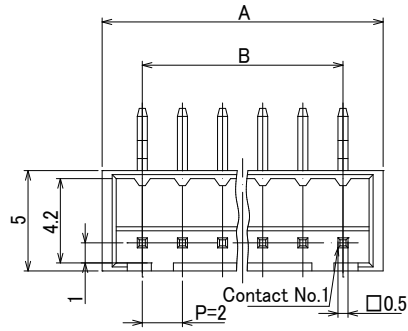

·Board Through-Hole Diameter : $\phi 0.8^{+0.1}_0$
 ·Kink Pre-Fixed Effective Diameter : $\phi 0.8^{+0.05}_0$

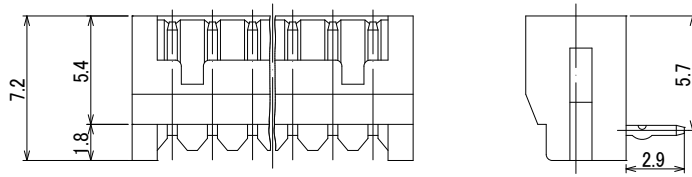

● Tin Plating

Unit : mm

Part No.	HRS No.	No. of Pos.	A	B	Purchase Unit
DF3A-2P-2DS	CL0543-0179-4-00	2	6	2	100pcs per bag
DF3A-3P-2DS	CL0543-0180-3-00	3	8	4	
DF3A-4P-2DS	CL0543-0181-6-00	4	10	6	
DF3A-5P-2DS	CL0543-0182-9-00	5	12	8	
DF3A-6P-2DS	CL0543-0183-1-00	6	14	10	
DF3A-7P-2DS	CL0543-0184-4-00	7	16	12	
DF3A-8P-2DS	CL0543-0185-7-00	8	18	14	
DF3A-9P-2DS	CL0543-0186-0-00	9	20	16	
DF3A-10P-2DS	CL0543-0187-2-00	10	22	18	
DF3A-11P-2DS	CL0543-0188-5-00	11	24	20	
DF3A-12P-2DS	CL0543-0189-8-00	12	26	22	
DF3A-13P-2DS	CL0543-0190-7-00	13	28	24	
DF3A-14P-2DS	CL0543-0191-0-00	14	30	26	
DF3A-15P-2DS	CL0543-0192-2-00	15	32	28	

● Gold Plating

Unit : mm

Part No.	HRS No.	No. of Pos.	A	B	Purchase Unit
DF3-2P-2DS(01)	CL0543-0031-3-01	2	6	2	100pcs per bag
DF3-3P-2DS(01)	CL0543-0032-6-01	3	8	4	
DF3-4P-2DS(01)	CL0543-0033-9-01	4	10	6	
DF3-5P-2DS(01)	CL0543-0034-1-01	5	12	8	
DF3-6P-2DS(01)	CL0543-0035-4-01	6	14	10	
DF3-7P-2DS(01)	CL0543-0036-7-01	7	16	12	
DF3-8P-2DS(01)	CL0543-0037-0-01	8	18	14	
DF3-9P-2DS(01)	CL0543-0038-2-01	9	20	16	
DF3-10P-2DS(01)	CL0543-0039-5-01	10	22	18	
DF3-11P-2DS(01)	CL0543-0040-4-01	11	24	20	
DF3-12P-2DS(01)	CL0543-0041-7-01	12	26	22	
DF3-13P-2DS(01)	CL0543-0042-0-01	13	28	24	
DF3-14P-2DS(01)	CL0543-0043-2-01	14	30	26	
DF3-15P-2DS(01)	CL0543-0044-5-01	15	32	28	

In-Line Plug

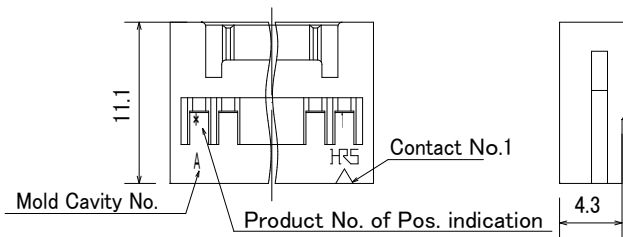
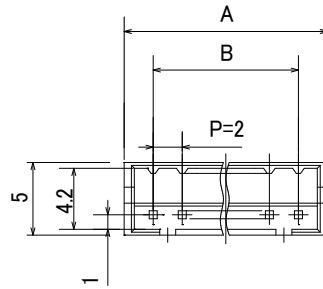

Unit : mm

Part No.	HRS No.	No. of Pos.	A	B	Purchase Unit
DF3-2EP-2C	CL0543-0064-2-00	2	6	2	100pcs per bag
DF3-3EP-2C	CL0543-0065-5-00	3	8	4	
DF3-4EP-2C	CL0543-0066-8-00	4	10	6	
DF3-5EP-2C	CL0543-0067-0-00	5	12	8	
DF3-6EP-2C	CL0543-0068-3-00	6	14	10	
DF3-7EP-2C	CL0543-0069-6-00	7	16	12	
DF3-8EP-2C	CL0543-0070-5-00	8	18	14	
DF3-9EP-2C	CL0543-0071-8-00	9	20	16	
DF3-10EP-2C	CL0543-0072-0-00	10	22	18	
DF3-11EP-2C	CL0543-0073-3-00	11	24	20	
DF3-12EP-2C	CL0543-0074-6-00	12	26	22	
DF3-13EP-2C	CL0543-0075-9-00	13	28	24	
DF3-14EP-2C	CL0543-0076-1-00	14	30	26	
DF3-15EP-2C	CL0543-0077-4-00	15	32	28	

In-Line Plug with Panel Lock

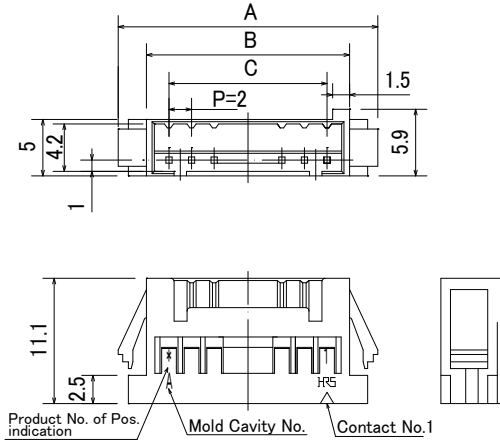

Unit : mm

Part No.	HRS No.	No. of Pos.	A	B	C	D	E	Purchase Unit
DF3AA-2EP-2C	CL0543-0151-5-00	2	11	6	2	9.4	6.3	100pcs per bag
DF3AA-3EP-2C	CL0543-0152-8-00	3	13	8	4	11.4	8.3	
DF3AA-4EP-2C	CL0543-0153-0-00	4	15	10	6	13.4	10.3	
DF3AA-5EP-2C	CL0543-0154-3-00	5	17	12	8	15.4	12.3	
DF3AA-6EP-2C	CL0543-0155-6-00	6	19	14	10	17.4	14.3	
DF3AA-7EP-2C	CL0543-0156-9-00	7	21	16	12	19.4	16.3	
DF3AA-8EP-2C	CL0543-0157-1-00	8	23	18	14	21.4	18.3	
DF3AA-9EP-2C	CL0543-0158-4-00	9	25	20	16	23.4	20.3	
DF3AA-10EP-2C	CL0543-0159-7-00	10	27	22	18	25.4	22.3	
DF3AA-11EP-2C	CL0543-0160-6-00	11	29	24	20	27.4	24.3	
DF3AA-12EP-2C	CL0543-0161-9-00	12	31	26	22	29.4	26.3	
DF3AA-13EP-2C	CL0543-0162-1-00	13	33	28	24	31.4	28.3	
DF3AA-14EP-2C	CL0543-0163-4-00	14	35	30	26	33.4	30.3	
DF3AA-15EP-2C	CL0543-0164-7-00	15	37	32	28	35.4	32.3	

Panel Cutouts

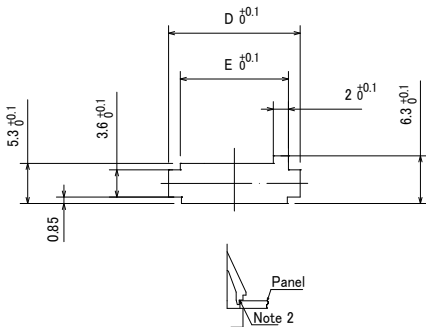

Note 1 : Applicable panel thickness is 1.6 to 1.0mm. (However, there is some rattling at thicknesses other than 1.6 and 1.2 mm.)

Note 2 : Use the non-radius surface at the hooking panel edge.

Note 3 : Contact No. indicates 1, 4, 8, 12, and 15.

Straight Pin Header (SMT)

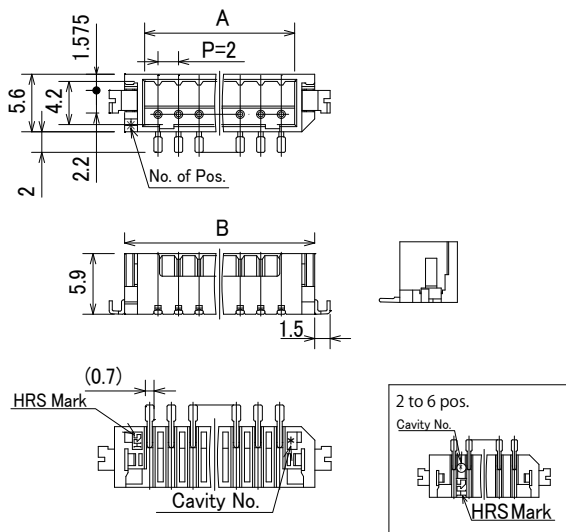

Unit : mm

Part No.	HRS No.	No. of Pos.	A	B	C	Purchase Unit
DF3EA-2P-2V(##)	CL0543-0315-0-##	2	2	8.5	8.74	1,000pcs per reel
DF3EA-3P-2V(##)	CL0543-0316-0-##	3	4	10.5	10.74	
DF3EA-4P-2V(##)	CL0543-0317-0-##	4	6	12.5	12.74	
DF3EA-5P-2V(##)	CL0543-0318-0-##	5	8	14.5	14.74	
DF3EA-6P-2V(##)	CL0543-0319-0-##	6	10	16.5	16.74	
DF3EA-7P-2V(##)	CL0543-0320-0-##	7	12	18.5	18.74	
DF3EA-8P-2V(##)	CL0543-0321-0-##	8	14	20.5	20.74	
DF3EA-9P-2V(##)	CL0543-0322-0-##	9	16	22.5	22.74	
DF3EA-10P-2V(##)	CL0543-0323-0-##	10	18	24.5	24.74	
DF3EA-11P-2V(##)	CL0543-0324-0-##	11	20	26.5	26.74	
DF3EA-12P-2V(##)	CL0543-0325-0-##	12	22	28.5	28.74	
DF3EA-13P-2V(##)	CL0543-0326-0-##	13	24	30.5	30.74	
DF3EA-14P-2V(##)	CL0543-0327-0-##	14	26	32.5	32.74	
DF3EA-15P-2V(##)	CL0543-0328-0-##	15	28	34.5	34.74	

[Specific No.] (##), ##
 (21) : Tin plated packaging
 (51) : Gold plated packaging

Note : For embossed tape dimensions, please refer to embossed tape carrier dimensions (JIS-C-0806 compliant).

■ PCB Mounting Pattern

Recommended PCB Layout

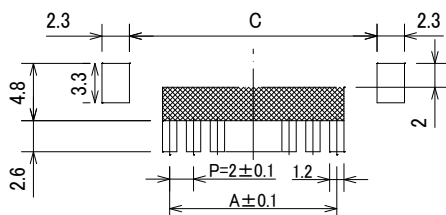

(Note) If there is a pattern on part xxx and no resist is applied, there is a possibility of contact with the connector terminals.

Right Angle Pin Header (SMT)

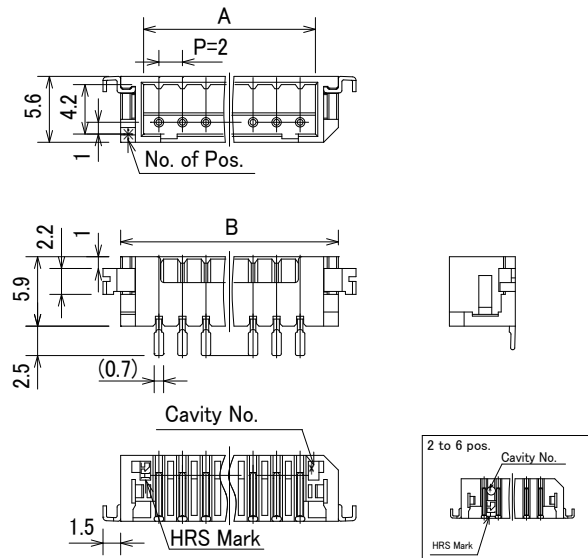
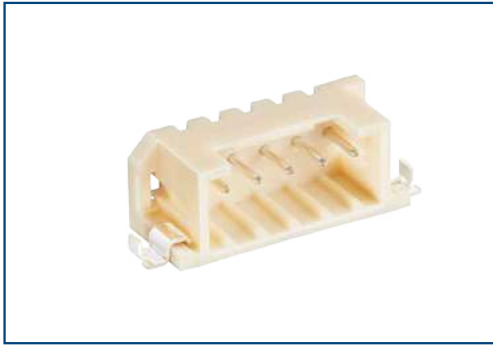

Unit : mm

Part No.	HRS No.	No. of Pos.	A	B	C	Purchase Unit
DF3EA-2P-2H(##)	CL0543-0329-0-##	2	2	8.5	8.74	1,000pcs per reel
DF3EA-3P-2H(##)	CL0543-0330-0-##	3	4	10.5	10.74	
DF3EA-4P-2H(##)	CL0543-0331-0-##	4	6	12.5	12.74	
DF3EA-5P-2H(##)	CL0543-0332-0-##	5	8	14.5	14.74	
DF3EA-6P-2H(##)	CL0543-0333-0-##	6	10	16.5	16.74	
DF3EA-7P-2H(##)	CL0543-0334-0-##	7	12	18.5	18.74	
DF3EA-8P-2H(##)	CL0543-0335-0-##	8	14	20.5	20.74	
DF3EA-9P-2H(##)	CL0543-0336-0-##	9	16	22.5	22.74	
DF3EA-10P-2H(##)	CL0543-0337-0-##	10	18	24.5	24.74	
DF3EA-11P-2H(##)	CL0543-0338-0-##	11	20	26.5	26.74	
DF3EA-12P-2H(##)	CL0543-0339-0-##	12	22	28.5	28.74	
DF3EA-13P-2H(##)	CL0543-0340-0-##	13	24	30.5	30.74	
DF3EA-14P-2H(##)	CL0543-0341-0-##	14	26	32.5	32.74	
DF3EA-15P-2H(##)	CL0543-0342-0-##	15	28	34.5	34.74	

[Specific No.] (##), ##
 (21) : Tin plated packaging
 (51) : Gold plated packaging

Note : For embossed tape dimensions, please refer to embossed tape carrier dimensions (JIS-C-0806 compliant).

PCB Mounting Pattern

Recommended PCB Layout

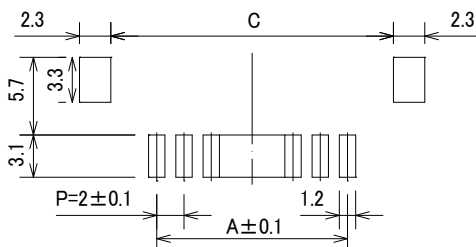

Crimping Contact for Socket

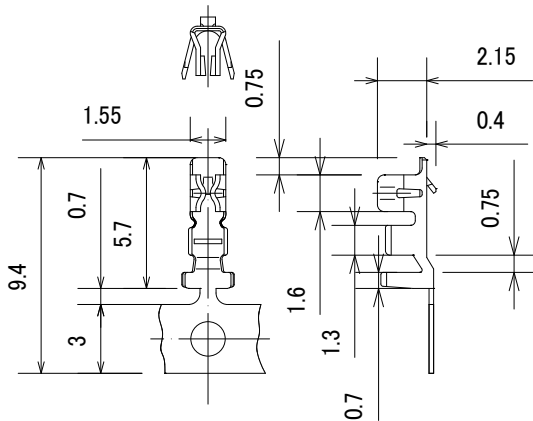

● Reel Contact (Applicable Tool : Applicator)

Part No.	HRS No.	Applicable Wire (Tin Plated Annealed Copper) (Note)				Purchase Unit	Finish
		UL	Jacket Diameter	AWG	Stranded Wire Structure		
DF3-22SCF	CL0543-0235-3-00	UL1061	1.2 to 1.5mm	22	17/0.16	10,000	Tin Plating
DF3-22SCFC	CL0543-0861-0-00			22	17/0.16		Gold Plating
DF3-2428SCF	CL0543-0001-2-00	UL1007 UL1061	0.75 to 1.5mm	24	11/0.16		Tin Plating
				26	7/0.16		
				28	7/0.127		
DF3-2428SCFC	CL0543-0046-0-00			24	11/0.16		Gold Plating
				26	7/0.16		
				28	7/0.127		

Note : When using other than the recommended wire, contact your nearest Hirose representative.

● Loose Piece Contact (Applicable Tool : Hand Crimping Tool)

Part No.	HRS No.	Applicable Wire (Tin Plated Annealed Copper) (Note)				Purchase Unit	Finish
		UL	Jacket Diameter	AWG	Stranded Wire Structure		
DF3-22SC	CL0543-0236-6-00	UL1061	1.3mm	22	17/0.16	100	Tin Plating
DF3-22SCC	CL0543-0862-3-00		1.3mm	22	17/0.16		Gold Plating
DF3-2428SC	CL0543-0002-5-00	UL1007	1.5mm	24	11/0.16		Tin Plating
			1.3mm	26	7/0.16		
			1.2mm	28	7/0.127		
DF3-2428SCC	CL0543-0047-3-00		1.5mm	24	11/0.16		Gold Plating
			1.3mm	26	7/0.16		
			1.2mm	28	7/0.127		

Note : When crimping with a manual crimping tool, only the wires listed above are compatible.

● Crimp Contact Extraction Tool : DF-C-PO(A)

Crimping Contact for In-Line Plug

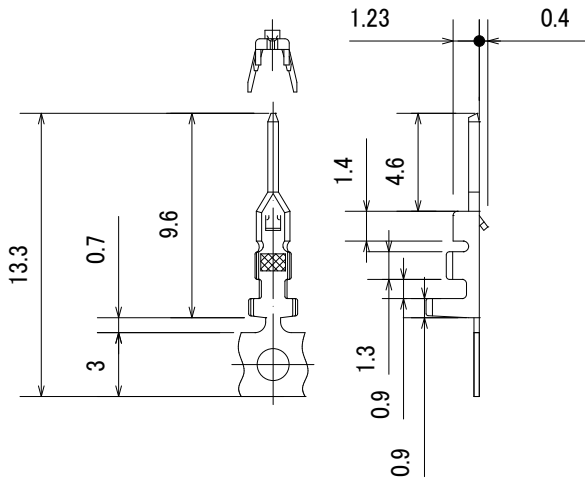

● Reel Contact (Applicable Tool : Applicator)

Part No.	HRS No.	Applicable Wire (Tin Plated Annealed Copper) (Note)				Purchase Unit	Finish
		UL	Jacket Diameter	AWG	Stranded Wire Structure		
DF3-EP2428PCF	CL0543-0062-7-00	UL1007 UL1061	0.75 to 1.5mm	24	11/0.16	10,000	Tin Plating
				26	7/0.16		
				28	7/0.127		
DF3-EP2428PCFA	CL0543-0149-3-00			24	11/0.16		Gold Plating
				26	7/0.16		
				28	7/0.127		

Note : When using other than the recommended wire, contact your nearest Hirose representative.

● Loose Piece Contact (Applicable Tool : Hand Crimping Tool)

Part No.	HRS No.	Applicable Wire (Tin Plated Annealed Copper) (Note)				Purchase Unit	Finish	
		UL	Jacket Diameter	AWG	Stranded Wire Structure			
DF3-EP2428PC	CL0543-0063-0-00	UL1007	1.5mm	24	11/0.16	100	Tin Plating	
				26	7/0.16			
				28	7/0.127			
DF3-EP2428PCA	CL0543-0150-2-00			1.5mm	24		11/0.16	Gold Plating
				1.3mm	26		7/0.16	
				1.2mm	28		7/0.127	

Note : When crimping with a manual crimping tool, only the wires listed above are compatible.

● Crimp Contact Extraction Tool : DF-C-PO(B)

Embossed Carrier Tape Dimensions (JIS-C-0806 Compliant)

Straight Pin Header

Embossed Tape Dimensions

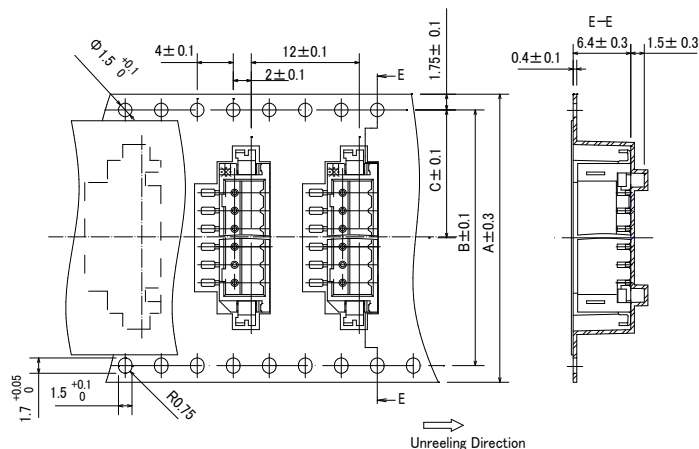

Reel Dimensions

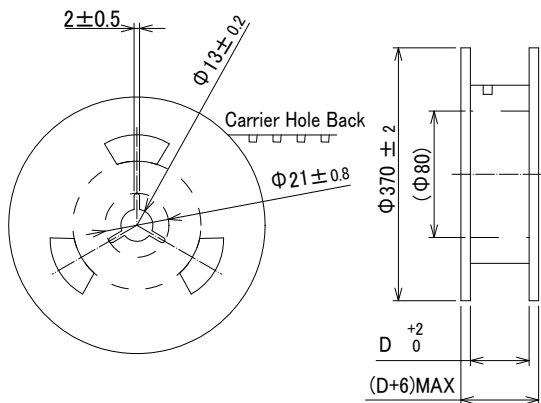

Unit : mm

Part No.	No. of Pos.	A	B	C	D	Purchase Unit
DF3EA-#P-2V(##)	2 to 4	24.0	-	11.5	24.4	1,000pcs per reel
	5 to 7	32.0	28.4	14.2	32.4	
	8 to 10	44.0	40.4	20.2	44.4	
	11 to 15	56.0	52.4	26.2	56.4	

Right Angle Pin Header

Embossed Tape Dimensions

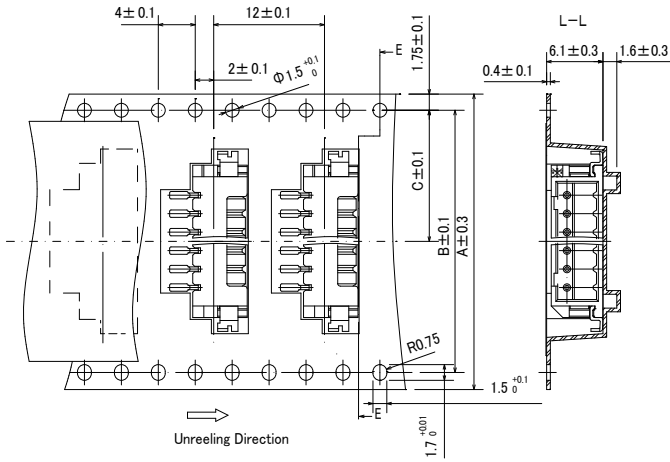

Reel Dimensions

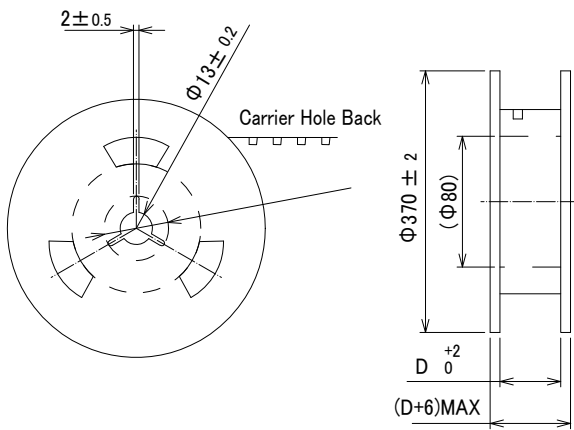

Unit : mm

Part No.	No. of Pos.	A	B	C	D	Purchase Unit
DF3EA-#P-2H(##)	2 to 4	24.0	-	11.5	24.4	1,000pcs per reel
	5 to 7	32.0	28.4	14.2	32.4	
	8 to 10	44.0	40.4	20.2	44.4	
	11 to 15	56.0	52.4	26.2	56.4	

Mated Dimensions

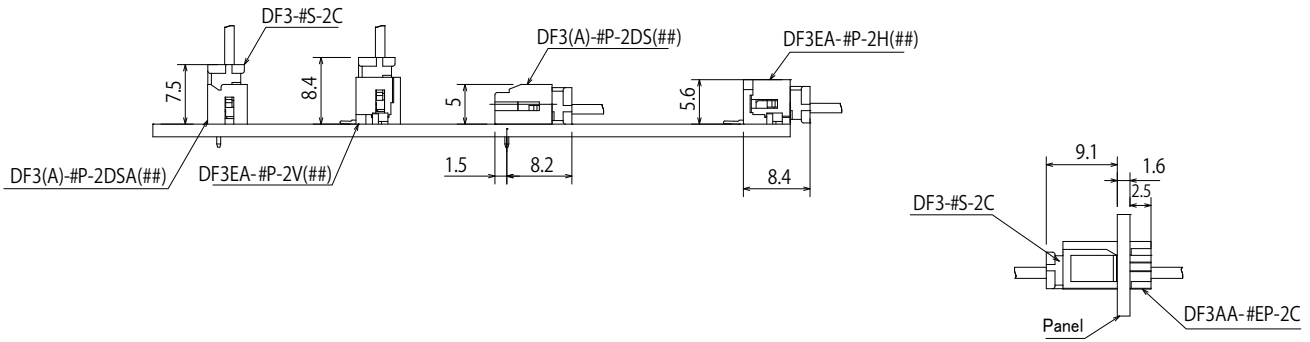

Applicable Crimping Tools

Type	Part No.	HRS No.	Applicable Contact
Applicator	AP105-DF3-2428S	CL0901-4503-3-00	DF3-2428SCF/SCFC
	AP105-DF3-22S	CL0901-4549-4-00	DF3-22SCF/SCFC
	AP105-DF3-EP2428P	CL0901-4508-7-00	DF3-EP2428PCF/PCFA
Press Body	CM-105C	CL0901-0001-0-00	-
Hand Tool	DF3-TA2428HC	CL0550-0164-5-00	DF3-2428SC/SCC
	DF3EP-TA2428HC	CL0550-0184-2-00	DF3-EP2428PC/PCA
	DF3-TA22HC	CL0550-0257-4-00	DF3-22SC/SCFC
Extraction Tool	DF-C-PO(A)	CL0550-0170-8-00	DF3-22SCF/SCFC DF3-22SC/SCC DF3-2428SCF/SCFC DF3-2428SC/SCC DF3-EP2428PCF/PCFA DF3-EP2428PC/PCA

Note 1 : Issues with non-Hirose specified tools are outside the scope of warranty.

Note 2 : Please conduct crimping work according to the Crimping Quality Standard "ETAD-H0958-00 and ETAD-H0959-00" and Crimp Conditions.

Note 3 : If you do not use our specified tools, please contact our sales representative for consultation on providing drawings.

Precautions for Crimping

■ Items Required Prior to Starting

The work-related documents listed below are required before starting harness assembly.

(The ● mark indicates a required document.)

When the documents shown below are not available, ask a Hirose sales personnel to provide them

Document Title	Description	Automatic Crimping Machine	Hand Crimping Tool	Remarks
① Instruction Manual for the Crimping Machine Main Unit	Explanation of main press machine unit	●	-	Bundled with the purchase of the main press machine unit.
② Applicator Handling Instructions	Crimping Operation Method			Bundled with the purchase of applicator.
③ Applicator Spare Parts Identification	Explanation for Applicator installation	●	-	
③ Crimp Conditions	Standard values of : Crimp Height, Tensile Strength	●	-	
④ Crimp Quality Standards ETAD-H0958-00 ETAD-H0959-00	Various standards for crimping conditions	●	-	
⑤ Operating Instructions for Hand Tool	Crimping Operation Method Standard values of : Crimp Height, Tensile Strength	-	●	Bundled with the purchase of hand tool.

■ Tools

Use tools designated by Hirose when crimping.

- Crimping performed using tools other than those specified is outside the scope of warranty.
 - The operating instructions manual is available for the crimping machine and the applicator.
- Be sure to carefully read the operating instructions manual before implementing the work.

■ Applicable Electric Wires

When using a wire other than the applicable wires please contact a Hirose representative.

[Precautions]

- Electric wires that are suitable for crimping connectors are tin-plated stranded soft copper wire.
- Avoid crimping solid wires, wires with polyester threads or tin-coated wires.
- Avoid crimping two electric wires together.
- The crimp height setting value (Note) may vary between tin-plated and gold-plated contacts even if the same electric wires are used.
- The crimp height setting value (Note) may vary depending on the difference in the core wire configuration even if the computed cross-sectional area is the same.

Note : The crimp height is an important item that determines crimping quality.

We execute crimping tests for each electric wire to ensure the optimal value for the crimp height with high precision, thereby ensuring optimal setup values.

Precautions

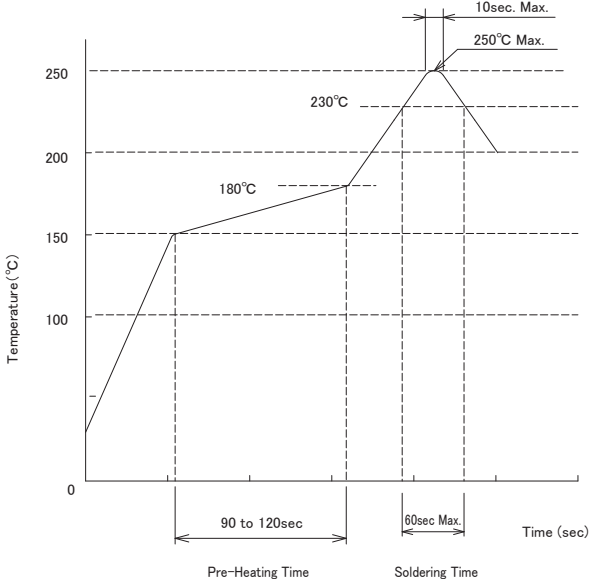
<p>Recommended Temperature Profile (SMT)</p>	 <p>[Condition]</p> <ol style="list-style-type: none"> 1. Peak Temperature : 250°C Max., within 10 sec. 2. Heating Section : 230°C Min., within 60 sec. 3. Pre-Heating Section : 150 to 180°C, 90 to 120 sec. 4. Frequency : within 2 times <p>*The measurement section is the terminal lead section. The type of cream solder, manufacturer, board size, and other mounting conditions may vary. Therefore, please check the mounting conditions before use. (Note1) This temperature profile is a recommended value.</p>
<p>Recommended Manual Soldering Conditions (SMT)</p>	<p>Soldering Iron Temperature : $290 \pm 10^{\circ}\text{C}$, Soldering Time : within 3 sec.</p>
<p>Recommended Screen Thickness (SMT)</p>	<p>0.15 to 0.2mm</p>
<p>Board Warpage (SMT)</p>	<p>Max. of 0.03mm at the center in reference to both ends of the connector</p>
<p>Recommended Soldering Conditions (DIP)</p>	<ul style="list-style-type: none"> ■ Flow Conditions with Automatic Soldering Equipment : Solder Temperature $250 \pm 5^{\circ}\text{C}$, Time within 10 sec. ■ Manual Soldering Conditions : Soldering Iron Temperature $290 \pm 10^{\circ}\text{C}$, Time within 2 sec.
<p>Cleaning</p>	<p>See Guidelines for Wire-to-Board Connectors (ETAD-H1023-00). IPA cleaning is allowed. (Cleaning is not recommended due to potential changes in mating action and other variables. Please contact us if you use other cleaning agents.)</p>
<p>Assembly</p>	<p>See Guidelines for Wire-to-Board Connectors (ETAD-H1023-00).</p>
<p>Precautions</p>	<p>Please refer to the following documents when handling this product.</p> <ul style="list-style-type: none"> ■ Crimp Quality Standard(ETAD-H0958-00, ETAD-H0959-00) ■ Guidelines for Wire-to-Board Connectors (ETAD-H1023-00)
<p>Handling Instructions</p>	<p>This product may have a slight differences in color depending on the production lot. This difference does not have any influence on the performance. In addition, black spots may appear on the mold resin, but this also does not affect the quality of the product.</p>

While Taking into Consideration

Specifications mentioned in this catalog are reference values.

When considering to order or use this product, please review the Drawing and Product Specifications sheets.

Use an appropriate cable when using the connector in combination with cables.

If considering usage of a non-specified cable, please contact your sales representative.

If assembly process is done by jigs & tools which are not identified by Hirose, the warranty of the product may be affected.

If considering usage for below mentioned applications, please contact your sales representative.

In cases where the application will demand a high level of reliability, such as automotive, medical instruments, public infrastructure, aerospace/defense etc. Hirose must review before assurance of reliability can be given.

HIROSE

HRS **HIROSE ELECTRIC CO.,LTD.**

2-6-3 Nakagawa Chuoh, Tsuzuki-Ku, Yokohama-Shi 224-8540, JAPAN
<https://www.hirose.com>