

Compact Economical,  
Plastic-body Limit Switch  
Featuring Direct Opening Action  
Contacts

- Positive opening mechanism (→)
- Two sets of contacts: one (NC) for safety circuit and the other (NO) for control circuit
- Enclosure ratings: IP67 NEMA 3, 4, 6P and 13
- Conforms to EN50047 with the Forms A, B, C, A to D, and E
- Four-position turret head
- Approved Standards



### Snap-action models (positive opening mechanism) (→)

Agency	Standard	File No.
TÜV Rheinland	EN60947-5-1	R9451193
UL (See Note 2.)	UL508 CSA C22.2 No.14	E76675
BIA	GS-ET-15, EN60947-5-1	1-conduit: 9509915
SUVA	SUVA	Approval pending











### Slow-action models (positive opening mechanism) (→)

Agency	Standard	File No.
TÜV Rheinland	EN60947-5-1	R9451184
UL	UL508 CSA C22.2 No.14	E76675
BIA (See Note 1.)	GS-ET-15, EN60947-5-1	1-conduit: 9407070
SUVA (See Note 1.)	SUVA	1-conduit: 5696

- Note: 1. Except for adjustable roller lever models.  
2. CSA C22.2 No. 14 compliance was verified and approved by UL (marked with  $c$  UL).

# Ordering Information

## ■ STANDARD SWITCH

Description		Part number		
Conduit type	Actuator	1NC ⊕ +1NO (Snap action)	1NC ⊕ +1NO (Slow action)	1NC ⊕ +1NO (Slow action)
1/2-14NPT (1-conduit)	Roller lever 	<b>D4D-3120N</b>	<b>D4D-3520N</b>	<b>D4D-3A20N</b>
	Adjustable nylon roller lever * 	<b>D4D-3121N</b>	<b>D4D-3521N</b>	<b>D4D-3A21N</b>
	Adjustable rubber roller lever * 	<b>D4D-3127N</b>	<b>D4D-3527N</b>	<b>D4D-3A27N</b>
	Plunger 	<b>D4D-3131N</b>	<b>D4D-3531N</b>	<b>D4D-3A31N</b>
	Roller plunger 	<b>D4D-3132N</b>	<b>D4D-3532N</b>	<b>D4D-3A32N</b>
	One-way roller arm lever (horizontal) 	<b>D4D-3162N</b>	<b>D4D-3562N</b>	<b>D4D-3A62N</b>
	One-way roller arm lever (vertical) 	<b>D4D-3172N</b>	<b>D4D-3572N</b>	<b>D4D-3A72N</b>
	Cat whisker ** 	<b>D4D-3180N</b>	—	<b>D4D-3A80N</b>
	Plastic rod ** 	<b>D4D-3187N</b>	—	<b>D4D-3A87N</b>

Note: “⊕” marking indicates the contacts which have positive opening mechanism approved by TÜV Rheinland.

\* The adjustable roller lever models are approved by the TÜV (EN standard) as positive opening, but they do not conform to the BIA (GS-ET-15 standard) and SUVA.

\*\* The cat whisker and plastic rod models are not approved by TÜV, BIA and SUVA as positive opening.

## ■ NOMENCLATURE

D4D - □ □ □ N

1 2 3

### 1. Conduit

- 1: PG13.5
- 2: G1/2
- 3: 1/2-14NPT

### 2. Built-in Switch

- 1: SPDB-1NC/1NO (Snap-action)
- 5: DPDB-1NC/1NO (Slow-action)
- A: DPST-2NC (Slow-action)

### 3. Actuator

- 20: Roller lever (standard)
- 21: Adjustable roller lever
- 27: Adjustable roller lever (with 50 dia. rubber roller)
- 31: Top plunger
- 32: Top roller lever
- 62: One-way roller arm lever (horizontal)
- 72: One-way roller arm lever (vertical)
- 80: Cat whisker
- 87: Plastic rod

# Specifications

## ■ RATINGS

IEC947-5-1 and EN60947-5-1

AC-15 2A/400V (TÜV File No. R9451193 and R9451184)

UL (UL508/CSA C22.2 No.14)

**NEMA A600 (Slow-action)**

Rated voltage	Current			Switching power	
	Continuous	Make	Break	Make	Break
120 VAC	10 A	60 A	6 A	7,200 VA	720 VA
240 VAC		30 A	3 A		
480 VAC		15 A	1.2 A		
600 VAC		12 A	1.2 A		

**NEMA B600 (Snap-action)**

Rated voltage	Current			Switching power	
	Continuous	Make	Break	Make	Break
120 VAC	5 A	30 A	3 A	3,600 VA	360 VA
240 VAC		15 A	1.5 A		
480 VAC		7.5 A	0.75 A		
600 VAC		6 A	0.6 A		

## General

Rated voltage	Non-inductive load				Inductive load			
	Resistive load		Lamp load		Inductive load		Motor load	
	NC	NO	NC	NO	NC	NO	NC	NO
125 VAC	10 A		3 A	1.5A	10 A		5 A	2.5A
250 VAC	10 A		2 A	1 A	10 A		3 A	1.5A
380 VAC	10 A		1.5A	0.8A	3 A		1.5A	0.8A
30 VDC	6 A		4 A	3 A	6 A		4 A	
125 VDC	0.8A		0.2A	0.2A	0.8A		0.2A	
250 VDC	0.4A		0.1A	0.1A	0.4A		0.1A	

- Note:
1. Resistive load has a power factor of  $\cos\phi = 1$ .
  2. Inductive load has a power factor of 0.4 min. (AC) and a time constant of 7 ms max. (DC).
  3. Lamp load has an inrush current of 10 times the steady-state current.
  4. Motor load has an inrush current of 6 times the steady-state current.

## ■ CHARACTERISTICS

Operating speed		1 mm/s to 50 cm/s (with D4D-1120N)
Operating frequency	Mechanical	120 operations/min
	Electrical	30 operations/min
Rated frequency		50/60 Hz
Insulation resistance		100 M $\Omega$ min. (at 500 VDC) between terminals of same polarity, and between each terminal and non-current-carrying metal part
Contact resistance		25 $\Omega$ max. (initial value)
Dielectric strength	Snap-action	1,000 VAC min. between terminals of same polarity 2,500 VAC min. between current-carrying metal part and ground, and between each terminal and non-current-carrying metal part
	Slow-action	Impulse dielectric strength ( $U_{imp}$ ) 4 kV between terminals of same polarity, between terminals of different polarity, between current-carrying metal part and ground, and between each terminal and non-current-carrying metal part
Rated insulation voltage ( $U_i$ )		400 V (EN60947-5-1)
Switching overvoltage		1,500 V max. (EN60947-5-1)
Pollution degree (operating environment)		3 (EN60947-5-1)
Short-circuit protective device (SCPD)		10 A, fuse type gI or gG (IEC269)
Conditional short-circuit current		100 A (EN60947-5-1)
Conventional enclosed thermal current ( $I_{the}$ )		10 A (EN60947-5-1)
Protection against electric shock		Class II (double insulation)
Vibration resistance		Malfunction: 10 to 500 Hz, 1.5-mm double amplitude
Shock resistance	Destruction	1,000 m/s <sup>2</sup> min. (approx. 100G min.)
	Malfunction	300 m/s <sup>2</sup> min. (approx. 30G min.)
Life expectancy	Snap-action	Mechanical: 15,000,000 operations min. Electrical: See "Engineering Data".
	Slow-action	Mechanical: 15,000,000 operations min. Electrical: 150,000 operations min.
Contact gap	Snap-action	2 x 0.5 mm min.
	Slow-action	2 x 2 mm min.
Bounce time	Snap-action	3 ms max.
	Slow-action	same as the operating speed
Ambient temperature		Operating: -30° to 70°C (-22° to 158°F) with no icing
Ambient humidity		Operating: 95% max.
Enclosure ratings	UL	Type 4
	NEMA	3, 4, 6P and 13
	IEC529	IP67 (EN60927-5-1)
Weight		Approx. 70 g (2.47 oz) (for D4D-1120N)

## ■ APPROVED STANDARDS

### Snap-action

UL508

CSA C22.2 No.14

EN 60947-1 Chap. 1 (File No. R9451193)

### Slow-action

UL508

CSA C22.2 No.14

EN 60947-5-1 Chap. 1, 3 (File No. R9451184) 

SUVA

BIA

## ■ OPERATING CHARACTERISTICS

### Snap-action (SPDB-1NC/1NO), Slow-action (DPDB-1NC/1NO)

Part number	D4D-□120N, D4D-□A20N	D4D-□121N, D4D-□A21N (See Note 1.)	D4D-□127N, D4D-□A27N (See Note 2.)
OF max.	4.9 N (1.10 lbf)	4.2 N (0.94 lbf)	4.2 N (0.94 lbf)
RF min.	0.5 N (0.11 lbf)	0.4 N (0.09 lbf)	0.4 N (0.09 lbf)
PT max.	18° to 27°		
OT min.	40°		
MD max. (See Note 3.)	14°		
OP	---		
TT (See Note 4.)	70°		
POT min. (See Note 5.)	50°		
POF min. (See Note 5.)	19.6 N (4.41 lbf)		

Part number	D4D-□131N, D4D-□A31N	D4D-□132N, D4D-□A32N	D4D-□162N, D4D-□A62N
OF max.	6.4 N (1.43 lbf)		3.9 N (0.88 lbf)
RF min.	1.5 N (0.34 lbf)		0.8 N (0.18 lbf)
PT max.	2 mm (0.08 inch)		4 mm (0.16 inch)
OT min.	4 mm (0.16 inch)		5 mm (0.20 inch)
MD max. (See Note 3.)	0.8 mm (.03 inch)	1 mm (0.04 inch)	1.5 mm (0.06 inch)
OP	18±0.5 mm (0.71±0.02 inch)	28.2±0.5 mm (1.11±0.02 inch)	37±0.8 mm (1.46±0.03 inch)
TT (See Note 4.)	6 mm (0.24 inch)		9 mm (0.35 inch)
POT min. (See Note 5.)	3.2 mm (0.13 inch)		5.8 mm (0.23 inch)
POF min. (See Note 5.)	19.6 N (4.41 lbf)		

Part number	D4D-□172N, D4D-□A72N	D4D-□180N, D4D-□A80N	D4D-□187N, D4D-□A87N
OF max.	4.4 N (0.99 lbf)	1.47 N (150 gf)	
RF min.	0.9 N (0.20 lbf)	---	
PT max.	4 mm (0.16 inch)	15°	
OT min.	5 mm (0.20 inch)	---	---
MD max. (See Note 3.)	1.5 mm (0.06 inch)	---	
OP	27±0.8 mm (1.06±0.03 inch)	---	
TT (See Note 4.)	9 mm (0.35 inch)	---	---
POT min. (See Note 5.)	5 mm (0.20 inch)	---	
POF min. (See Note 5.)	19.6 N (4.41 lbf)	---	---

- Note: 1. The operating characteristics of these switches were measured with the roller lever set at 30 mm (1.18 inch).  
 2. The operating characteristics of these switches were measured with the roller lever set at 31 mm (1.22 inch).  
 3. Only for snap-action models.  
 4. Nominal value.  
 5. Only for slow-action models.

## Slow-action (1NC/1NO)

Part number	D4D-□520N	D4D-□521N (See Note 1.)	D4D-□527N (See Note 2.)	D4D-□531N	D4D-□532N	D4D-□562N	D4D-□572N
OF max.	4.9 N (1.10 lbf)	4.2 N (0.94 lbf)	4.2 N (0.94 lbf)	6.4 N (1.44 lbf)		3.9 N (0.88 lbf)	4.4 N (0.99 lbf)
RF min.	0.5 N (0.11 lbf)	0.4 N (0.09 lbf)	0.4 N (0.09 lbf)	1.5 N (0.34 lbf)		0.8 N (0.18 lbf)	0.9 N (0.20 lbf)
PT max.	18° to 27°			2 mm (0.08 inch)		4 mm (0.16 inch)	
PT (2nd)	44°			2.9 mm (0.11 inch)		5.2 mm	4.3 (0.17 inch) mm
OT min.	40°			4 mm (0.16 inch)		5 mm (0.20 inch)	
OP	---			18±0.5 mm (0.71±0.02 inch)	28.2±0.5 mm (1.11±0.02 inch)	37±0.8 mm (1.46±0.03 inch)	27±0.8 mm (1.06±0.03 inch)
TT	70°			6 mm (0.24 inch)		9 mm (0.35 inch)	
POT min.	50°			3.2 mm (0.13 inch)		5.8 mm (0.23 inch)	4.8 mm (0.19 inch)
POF min.	19.6 N (4.41 lbf)			19.6 N (4.41 lbf)			

Note: 1. The operating characteristics of these switches were measured with the roller lever set at 30 mm (1.18 inch).

2. The operating characteristics of these switches were measured with the roller lever set at 31 mm (1.22 inch).

## Engineering Data

### ■ ELECTRICAL LIFE EXPECTANCY (1NC/1NO CONTACT, SNAP-ACTION)

( $\cos\phi = 1$ )

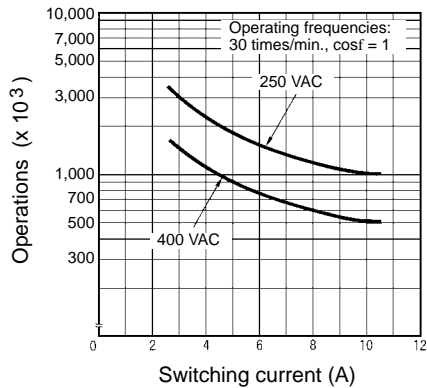

( $\cos\phi = 0.4$ )

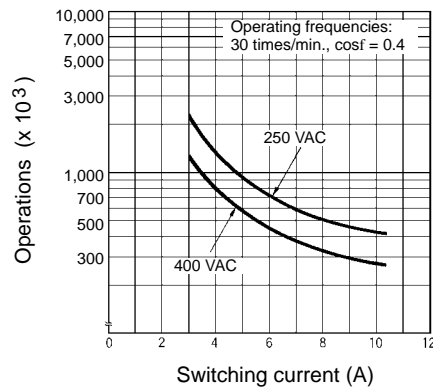

## Construction

### Head

With roller lever switches, the direction of the switch head can be varied to any of the four directions by loosening the roller lever switch screws at the four corners of the head.

### Built-in Switch

Wide switch variations.  
Snap-action: 1NC/1NO  
Slow-action: 1NC/1NO  
2NC

### Conduit Opening

Available in three different types of conduit threads:  
PG 13.5: European standard  
G 1/2: Japanese standard  
1/2-14NPT: U.S. standard

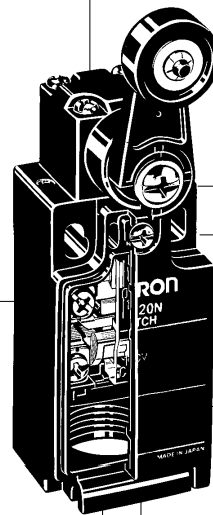

### Safety-oriented Lever Setting

Grooves which engage the lever every 90° are cut in the operation indicator disk to prevent the lever from slipping against the rotary shaft.

### Cover

Easy to open and wire. (One mounting screw and opposite side is for hinge mounting.)

### Contact Material

Ag alloy

### Conduit Cap

Can be used as a simple connector under good environmental conditions.

## Operation

### ■ DIRECT OPENING ACTION

#### NO/NC Contact (Snap-action)

If metal deposition between mating contacts occurs on the NC contact side, they can be pulled apart by the shearing force and tensile force generated when part B of the safety cam or plunger engages part A of the movable contact blade. When the safety cam or plunger is moved in the direction of the black arrow, the limit switch releases.

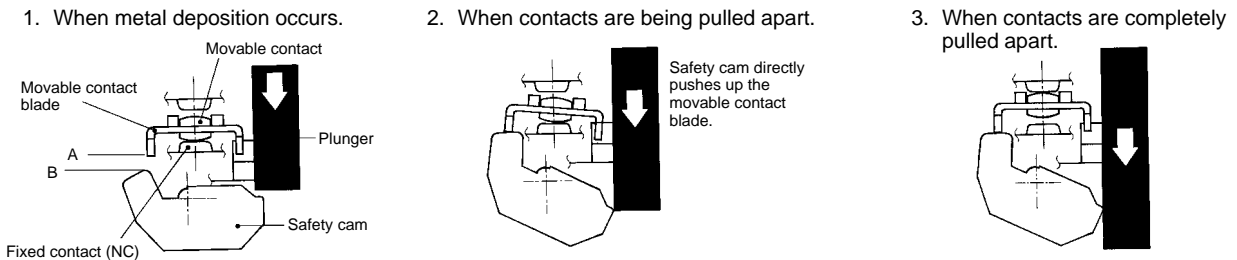

**DPDT-1NC/1NO Contact (Slow-action)**

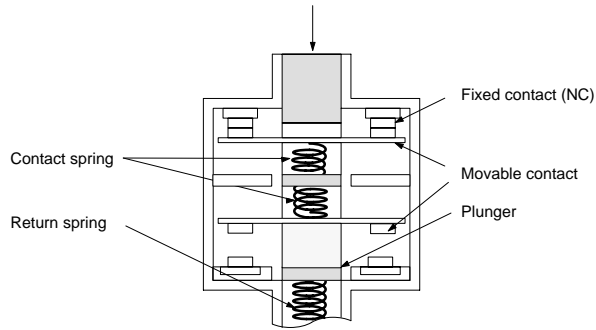

Conforms to IEC 947-5-1 Chapter 3  
When metal deposition occurs, the contacts are separated from each other by the plunger being pushed in.



**DPDT-2NC Contact (Slow-action)**

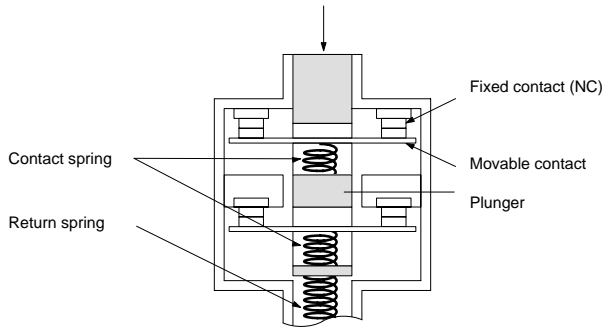

Conforms to IEC 947-5-1 Chapter 3  
When metal deposition occurs, the contacts are separated from each other by the plunger being pushed in.



**CONTACT FORM (EN50013)**

Model	Contact	Diagrams (see note)
D4D-□1□N		
D4D-□5□N		
D4D-□A□N		

Note: Contact operation

Closed    
 Open

# Dimensions

Unit: mm (inch)

Note: 1. Unless otherwise specified, a tolerance of  $\pm 0.4$  mm applies to all dimensions.

2. When placing your order, specify the conduit type by adding a code from the list below to the blank box of the following model numbers as shown below.

1:PG 13.5

2:G 1/2

3:1/2-14NPT (1-conduit)

D4D-□120N

D4D-□520N

D4D-□A20N

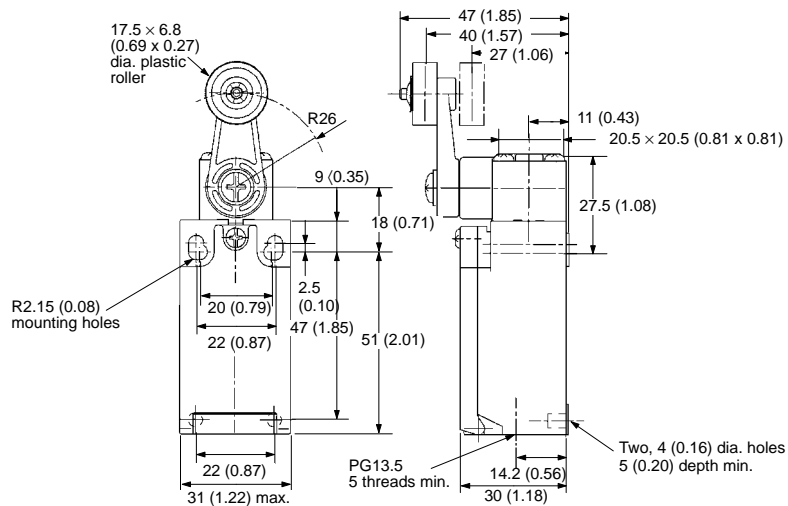

D4D-□121N

D4D-□521N

D4D-□A21N

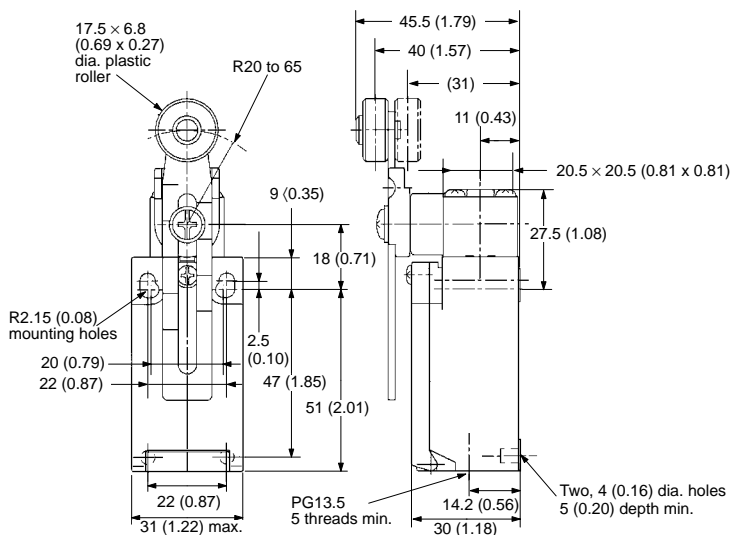
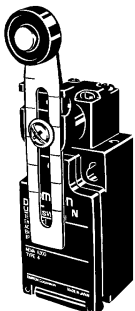

D4D-□127N  
 D4D-□527N  
 D4D-□A27N

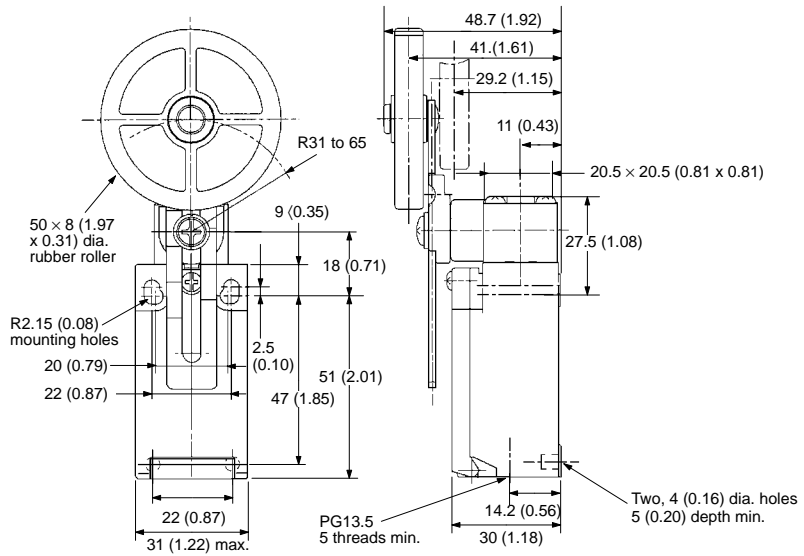
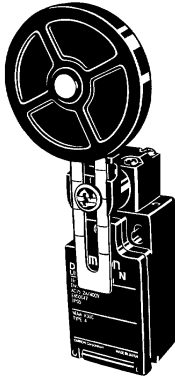

D4D-□131N  
 D4D-□531N  
 D4D-□A31N

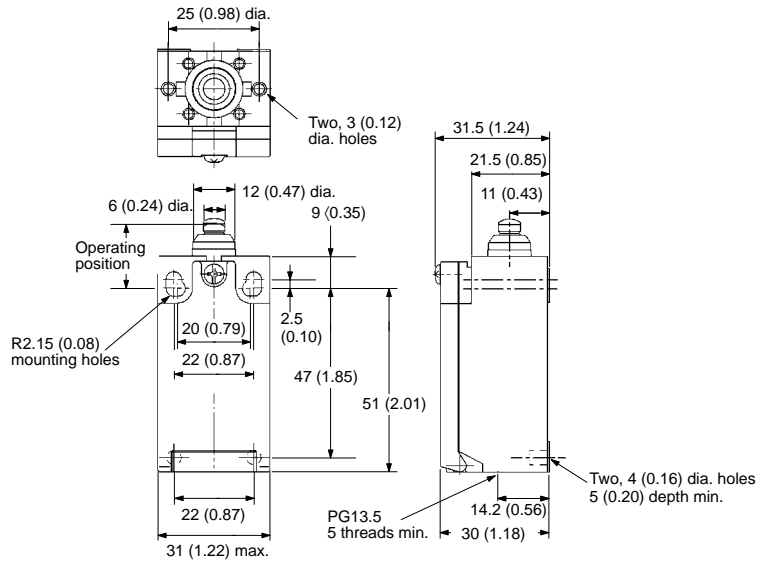

D4D-□132N  
 D4D-□532N  
 D4D-□A32N

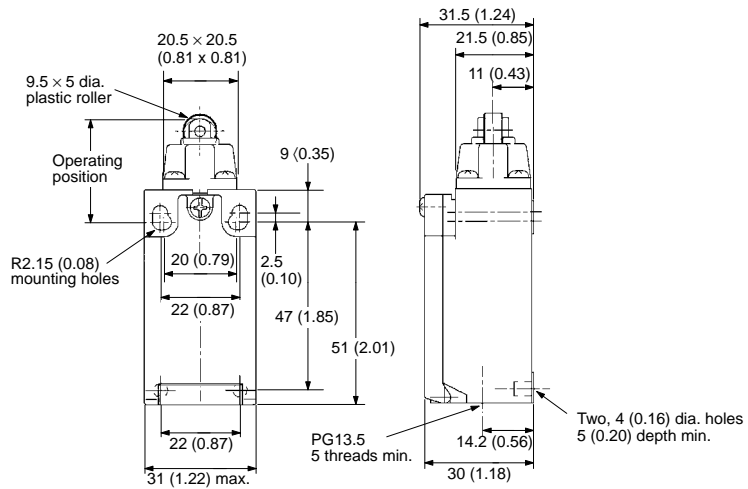

D4D-□162N  
 D4D-□562N  
 D4D-□A62N

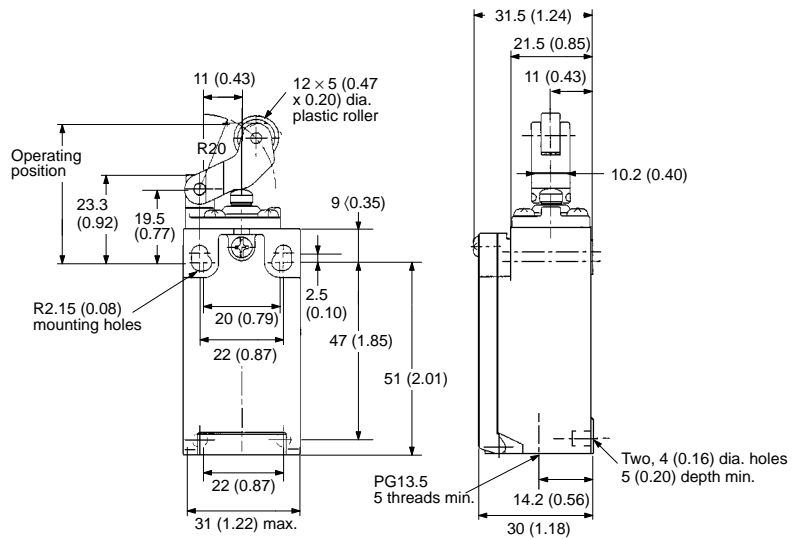

D4D-□172N  
 D4D-□572N  
 D4D-□A72N

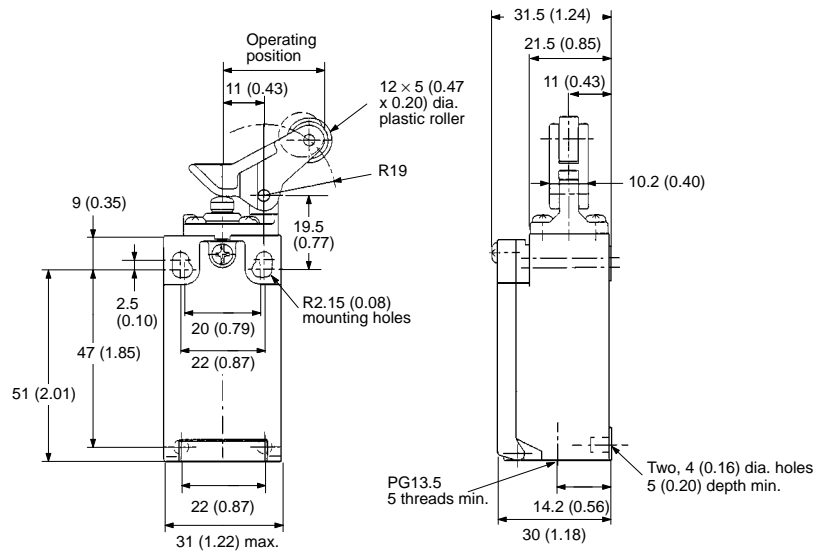

LEVERS

Refer to the following for the angles and positions of the watchdogs.

**Roller Lever**  
(D4D-□□20N)

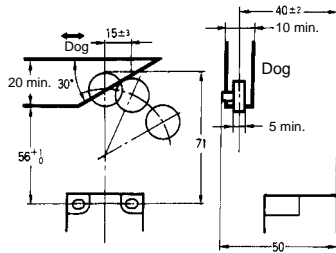

**Adjustable Roller Lever**  
(D4D-□□21N) (Reference Value)

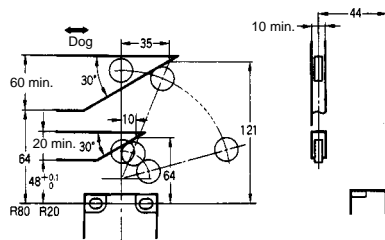

**Rubber Roller Lever**  
(D4D-□□27N) (Reference Value)

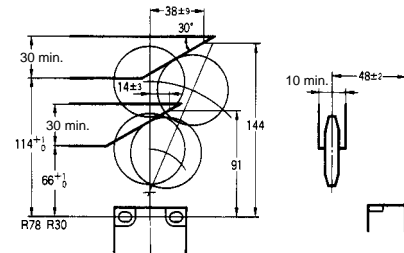

**Sealed Plunger**  
(D4D-□□31N)

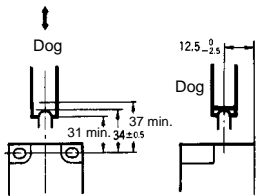

**Roller Plunger**  
(D4D-□□32N)

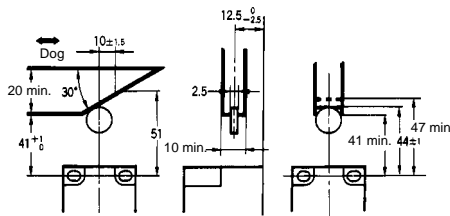

**One-way Roller Arm Lever (Horizontal)**  
(D4D-□□62N)

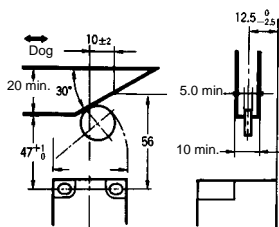

**One-way Roller Arm Lever (Vertical)**  
(D4D-□□72N)

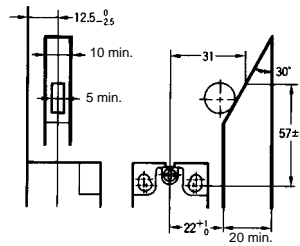

# Precautions

## ■ WARNINGS AND CAUTIONS

### ⚠ CAUTION

Connect in series a specified short-circuit protection device to protect the switch from overcurrent. The switch will overheat if current is flowing over a long period, thus resulting in a fire.

### ⚠ CAUTION

Do not use metal connectors or metal pipes, or damage to the conduit sections will occur.

### ⚠ CAUTION

The switch is designed for indoor use. If used outdoors, it will malfunction.

## ■ MOUNTING SCREW TIGHTENING TORQUE

Refer to the following and tighten each screw of the D4D-□N properly, otherwise the D4D-□N may malfunction.

No.	Type	Torque
(1)	Terminal screw	0.4 to 0.6 N • m (4 to 6 kgf • cm)
(2)	Cover tightening screw	0.78 to 0.88 N • m (8 to 9 kgf • cm)
(3)	Head mounting screw	0.78 to 0.88 N • m (8 to 9 kgf • cm)
(4)	Lever tightening screw	1.57 to 1.77 N • m (16 to 18 kgf • cm)
(5) (See Note 1.)	Switch mounting screw (M4, M3.5)	0.49 to 0.69 N • m (5 to 7 kgf • cm) 0.98 to 1.18 N • m (10 to 12 kgf • cm)
(6) (See Note 2.)	Connector	1.4 to 1.8 N • m (14 to 18 kgf • cm) 1.8 to 2.2 N • m (18 to 22 kgf • cm)
(7)	Cap screw	1.3 to 1.7 N • m (13 to 17 kgf • cm)

- Note:**
- When mounting a plunger-type head to a panel, use a flat-head screw with a washer and tighten the flat-head screw to the specified torque.
  - This applies to the 1/2-14NPT connector.

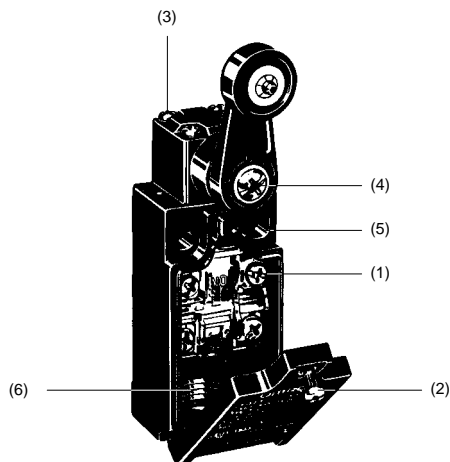

## ■ OPERATION

The angle, moving speed, and moving direction of a dog used with the D4D-□N must be in conformity with the specified angle, moving speed, and moving direction, otherwise the D4D-□N may malfunction.

### Example

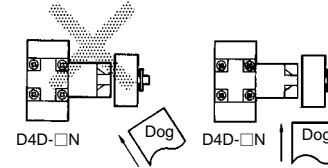

Do not use a 90° dog with the D4D-□N.

## ■ MOUNTING

### Mounting Holes/Studs

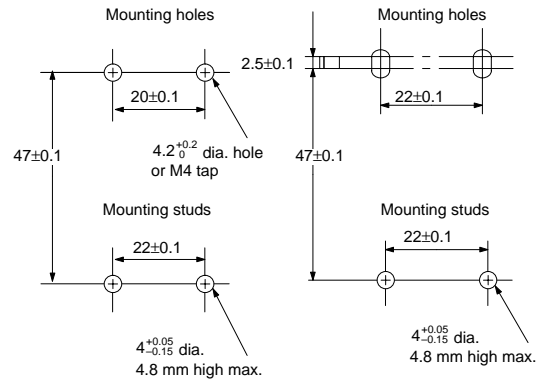

### ■ LEVER ANGLE

The angle of the lever can be changed with 7.5-degree increments from 0 to 360 degrees.

To adjust the length of the variable roller lever, loosen the lever mounting screw.

To mount the lever to the opposite side of the D4D-□N, loosen the lever mounting screw to disconnect the lever and mount the lever to the opposite side so that the lever will not touch the reset button or the casing.

### ■ CHANGING THE ACTUATOR MOUNTING POSITION

After changing the direction of the head, make sure that the head is mounted with the specified torque. Each head mounting screw must be tightened equally. Make sure that there is no foreign substance in the screw holes when tightening the head mounting screws.

### ■ WIRING

When wiring, do not connect the lead wire directly to the terminal, but use an insulation tube and crimp-type terminal. Tighten to a torque 0.4 to 0.6 N • m (4 to 6 kgf • cm). The lead wire must be between AWG20 and AWG14 (0.5 to 2.5 mm<sup>2</sup>).

Be careful not to touch the terminals while power is being supplied in order to avoid any electrical shock.

### ■ CONDUIT

Do not use any metal connector or conduit with the D4D-□N, otherwise the conduit hole of the D4D-□N may be damaged. To keep the D4D-□N meeting the requirements of IP65, protect the conduit hole side of the connector with sealing tape. Use a cable with a diameter suitable for the connector.

**NOTE: DIMENSIONS SHOWN ARE IN MILLIMETERS. To convert millimeters to inches divide by 25.4.**

# OMRON<sup>®</sup>

**OMRON ELECTRONICS, INC.**

One East Commerce Drive  
Schaumburg, IL 60173

**1-800-55-OMRON**

**OMRON CANADA, INC.**

885 Milner Avenue  
Scarborough, Ontario M1B 5V8

**416-286-6465**