

Sealed Ultra Subminiature Basic Switch D2EW

Supports multi-angle operation without using a lever, increased flexibility in customer unit design

- The industry's smallest class *(8.3 x 7.0 x 5.3 mm) D2GW equivalent size
- Misassembly is prevented with a left-right asymmetrical post shape
- A sliding contact structure delivers quiet operation
- Contributes to energy saving (Minimum applicable load 50 μ A)

* Based on OMRON investigation in January 2023

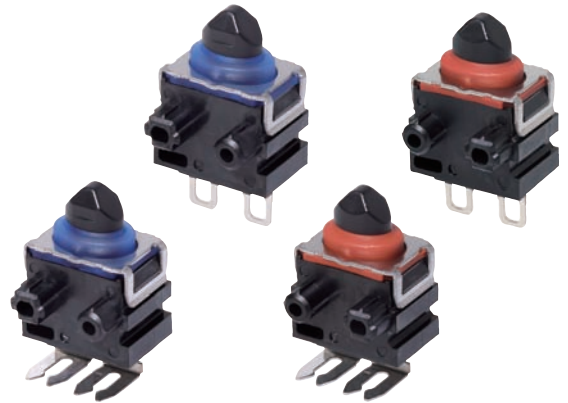

Model Number Legend

Some model number elements cannot be used in conjunction.

If you have any desired model with a specification not in this model number legend, contact your OMRON sales representative. We will consider if a requested model can be manufactured by modifying existing models.

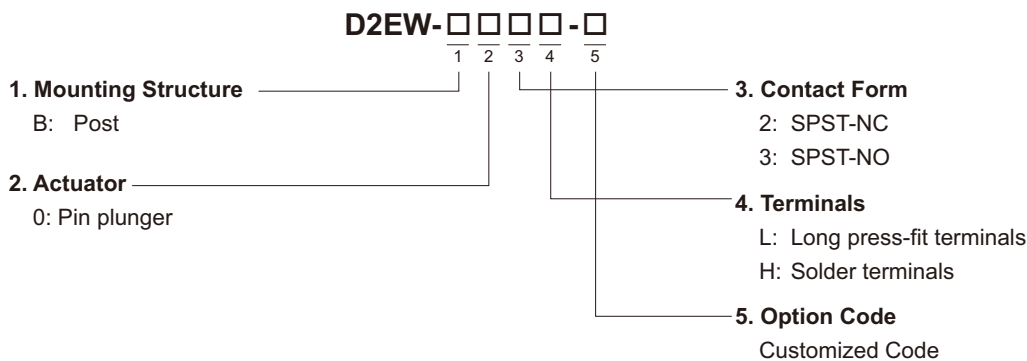

D2EW

List of Models

			Model	Post
Actuator	Terminals	Contact Form		
Pin plunger 	Long press-fit terminals	SPST-NC		D2EW-B02L
		SPST-NO		D2EW-B03L
	Solder terminals	SPST-NC		D2EW-B02H
		SPST-NO		D2EW-B03H

If you have any desired model with a specification not in the above list, contact your OMRON sales representative. We will consider if a requested model can be manufactured by modifying existing models.

Contact Specifications

Contact	Specification	Slide
	Material	Gold plated
Minimum applicable load (see note)		5 VDC 50 μ A

Note: For more information on the minimum applicable load, refer to *Using Micro Loads of Precaution*.

Ratings

Rating voltage	Resistive load
12 VDC	0.1 A

Note: The rating values apply under the following test conditions.

1. Ambient temperature: $20 \pm 2^{\circ}\text{C}$
2. Ambient humidity: $65 \pm 5\%$
3. Operating frequency: 30 operations/min

Characteristics

Items		
Operating speed		30 mm to 500 mm/s (pin plunger models)
Operating frequency	Mechanical	30 operations/min Max.
	Electrical	30 operations/min Max.
Insulation resistance		100 M Ω Min. (at 500 VDC)
Contact resistance (initial value)	Terminals	500 m Ω Max.
Dielectric strength	Between same polarity	500 VAC 50/60 Hz 1 min
	Between current carrying metal parts and ground	1,500 VAC 50/60 Hz 1 min
Vibration resistance *1	Malfunction	10 to 55 Hz, 1.5 mm double amplitude
Shock resistance	Destruction	1,000 m/s ² Max.
	Malfunction *1	300 m/s ² Max.
Durability *2	Mechanical	300,000 operations Min. (at 30 operations/min)
	Electrical	300,000 operations Min. (at 30 operations/min)
Degree of protection		IEC IP67 (excluding the terminals)
Ambient operating temperature		-40 to +85°C (at 60% RH Max.)(with no icing or condensation)
Ambient operation humidity		95%RH Max. (for +5 to +35°C)
Heat resistance		85°C 500 hours
Cold resistance		-40°C 500 hours
Humidity resistance		85°C 85% RH 500 hours
Temperature cycle resistance		-40°C (0.5hours) \leftrightarrow 85°C (0.5 hours) 500 cycles
Weight		Approx. 0.5 g (for pin plunger models with terminals)

Note: The data given above are initial values.

- *1. For the pin plunger models, the above values apply for use at the free position, and total travel position. Close or open circuit of the contact is 1 ms Max.
- *2. For testing conditions, consult your OMRON sales representative.

D2EW

Mounting Structure and Reference Positions for Operating Characteristics (Unit: mm)

● Post/SPST-NO D2EW-B03□

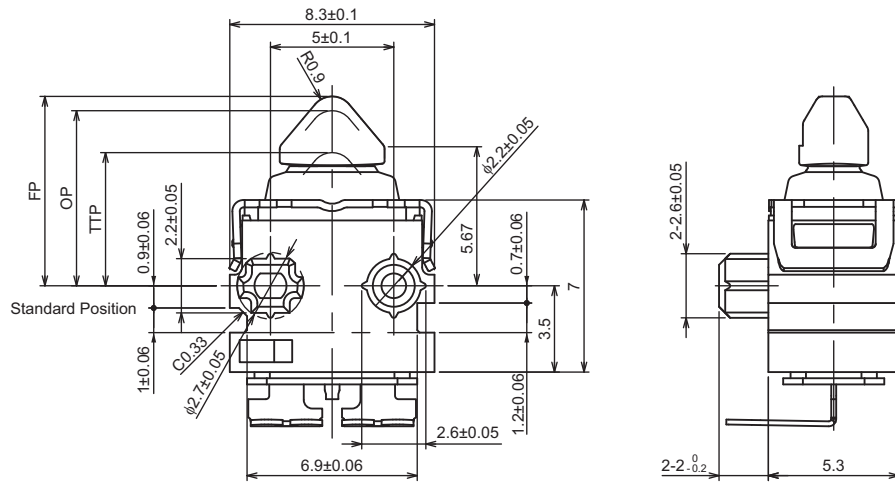

● Post/SPST-NC D2EW-B02□

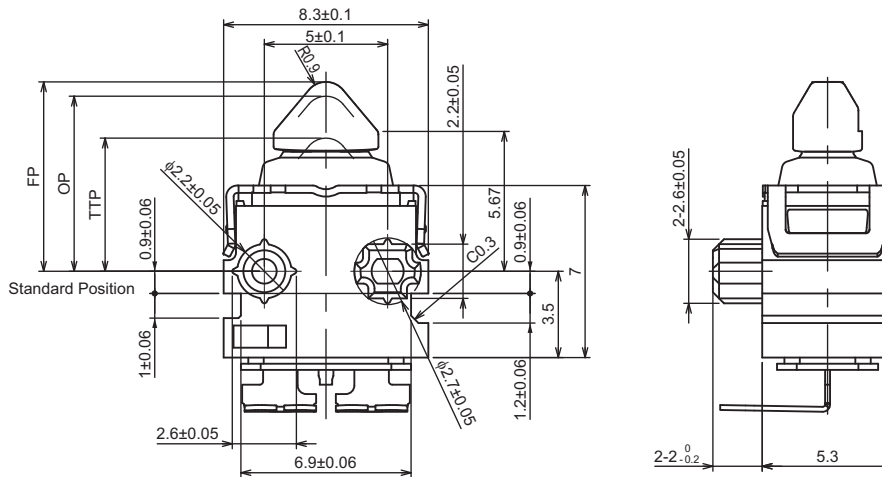

Operation allowable angle

It can be operated not only from above, but also from the side up to 90 degrees.

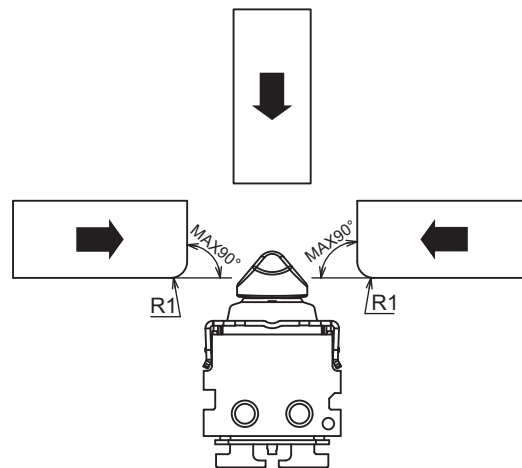

Terminals (Unit: mm)

● Long press-fit terminals SPST-NO

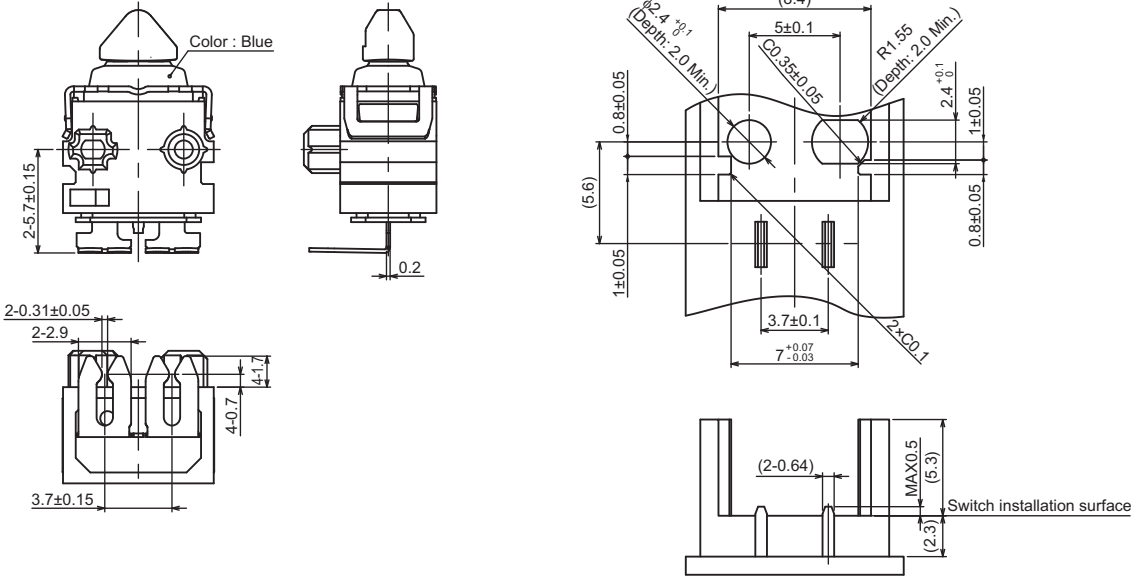

SPST-NC

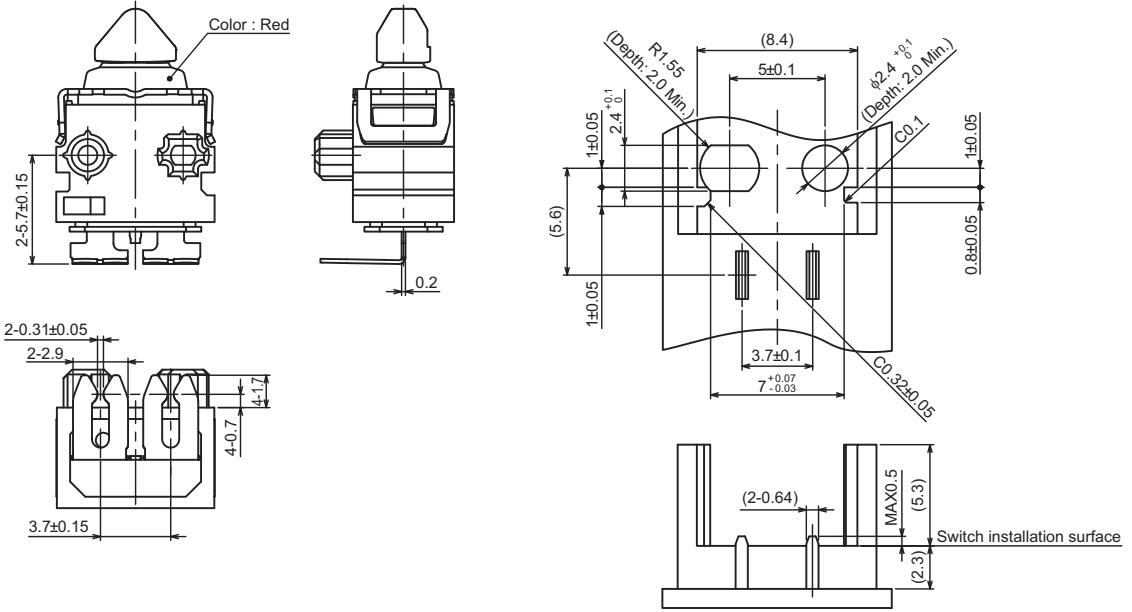

● Solder terminals SPST-NO

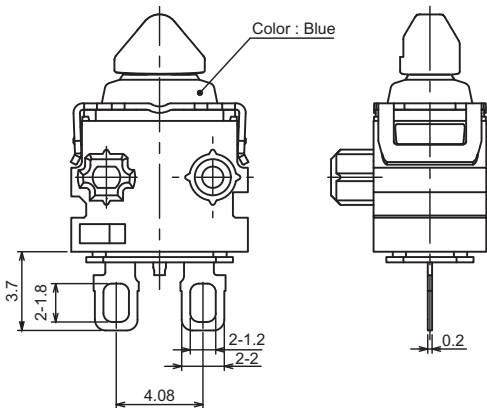

SPST-NC

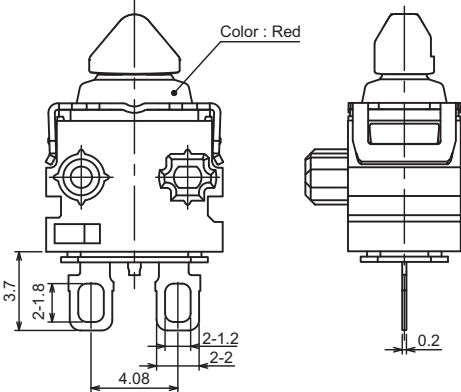

D2EW

Dimensions (Unit: mm) / Operating Characteristics

CAD Data Please visit our website, which is noted on the last page.

The following drawing is for example model. When ordering, replace □ with the code for the rating that you need. For the combination of models, refer to *List of Models*.

● Pin plunger D2EW-□0□□

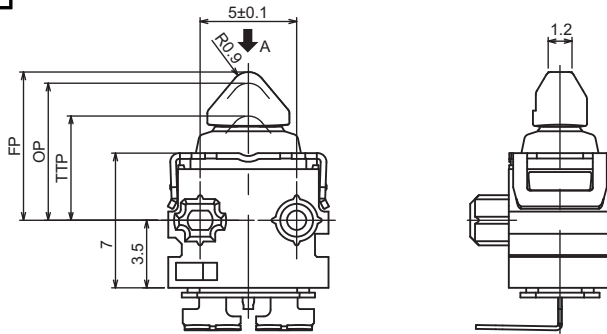

Operating characteristics	Type	Side slot
Operating Force	OF Max.	1.2 N {122 gf}
Releasing Force	RF Min.	0.1 N {10 gf}
Overtravel	OT	1.7 mm (reference value)
Movement Differential	MD Max.	
Free Position	FP Max.	7.8 mm
Operating Position	OP	7.1±0.2 mm
Total Travel Position	TTP	5.4 mm

CAD Data

- Note:**
1. Unless otherwise specified, a tolerance of ± 0.2 mm applies to all dimensions.
 2. The operating characteristics are for operation in the A direction (↓).

Precautions

Please refer to "Safety Precautions for All Detection Switches" for correct use.

Cautions

● Degree of Protection

- Do not use this product underwater.

Satisfy the test conditions for the standard given below, this test is to check the ingress of water into the switch enclosure after submerging the Switch in water for a given time.

Satisfying this test condition does not mean that the Switch can be used underwater.

JIS C0920:

Degrees of protection provided by enclosures of electrical apparatus (IP Code)

IEC 60529:

Degrees of protection provided by enclosures (IP Code)

Degree of protection: IP67

(check water intrusion after immersion for 30 min. submerged 1m underwater)

- Do not operate the Switch when it is exposed to water spray, or when water drops adhere to the Switch surface, or during sudden temperature changes, otherwise water may intrude into the interior of the Switch due to a suction effect.
- Prevent the Switch from coming into contact with oil and chemicals. Otherwise, damage to or deterioration of Switch materials may result.
- Do not use the Switch in areas where it is exposed to silicon adhesives, oil, or grease. Otherwise faulty contact may result due to the generation of silicon oxide.

● Soldering

When soldering the lead wire to the terminal, first insert the lead wire conductor through the terminal hole and then conduct soldering.

Make sure that the temperature of the soldering iron tip does not exceed 300°C, and complete the soldering within 3 seconds. Do not apply any external force for 1 minute after soldering.

Soldering at an excessively high temperature or soldering for more than 3 seconds may deteriorate the characteristics of the Switch.

In case of automatic soldering, please do not apply the heat beyond 260°C within 5 seconds. Pay careful attention so that flux or solder liquid does not flow over the edge of the PCB panel.

● Side-actuated (Cam/Dog) Operation

- When using a cam or dog to operate the Switch, factors such as the operating speed, operating frequency, push-button indentation, and material and shape of the cam or dog will affect the durability of the Switch. Confirm performance specifications under actual operating conditions before using the Switch in applications.

Correct Use

● Mounting

- Turn OFF the power supply before mounting or removing the Switch, wiring, or performing maintenance or inspection. Failure to do so may result in electric shock or burning.
- For models with posts, secure the posts by pressing into an attached device. Provide guides on the opposite ends of the posts to ensure that they do not fall out or rattle.
- When mounting a Press-fit terminals, press in A (body) and B (terminal) in the drawing below at the same time. If A (body) only is pressed in, the Press-fit terminals will be deformed and will not be properly inserted. Also, ensure that the Press-fit terminals is facing down when it is inserted. Avoid connecting soldered or laser-welded terminals. Avoid mounting in conditions exposed to corrosive gases, high temperature and humidity, and dust.

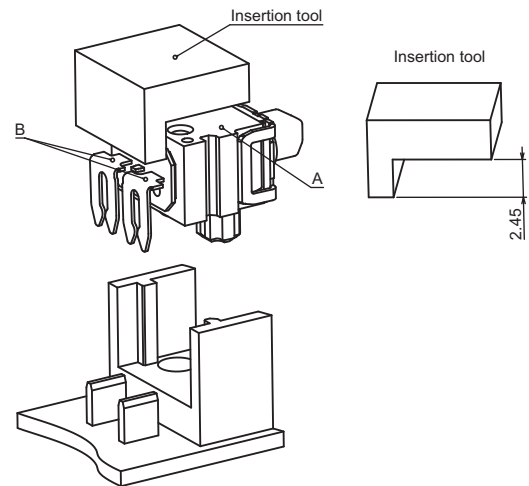

● Operating Body

- Use an operating body with low frictional resistance and of a shape that will not interfere with the sealing rubber, otherwise the plunger may be damaged or the sealing may deteriorate.

● Handling

- Do not handle the Switch in a way that may cause damage to the sealing rubber.
- Ensure that uneven pressure or pressure in a direction other than the operating direction is not applied to the Pin plunger, Post and Terminal as shown in the following diagram. Otherwise the Pin plunger, Post and Terminal, or Switch may be damaged, or the service life may be reduced.

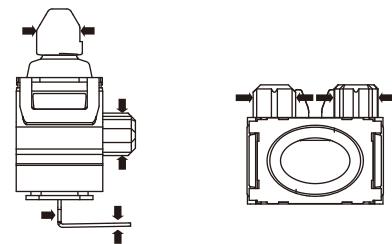

● Using Micro Loads

- Even when using micro load models within the specification range, if inrush/surge current occurs, it may increase the contact wear and so decrease durability. Therefore, insert a contact protection circuit where necessary.

Please check each region's Terms & Conditions by region website.

OMRON Corporation
Device & Module Solutions Company

Regional Contact

Americas

<https://components.omron.com/us>

Asia-Pacific

<https://components.omron.com/ap>

Korea

<https://components.omron.com/kr>

Europe

<https://components.omron.com/eu>

China

<https://components.omron.com.cn>

Japan

<https://components.omron.com/jp>

Mouser Electronics

Authorized Distributor

Click to View Pricing, Inventory, Delivery & Lifecycle Information:

[Omron:](#)

[D2EW-B02H](#) [D2EW-B02L](#) [D2EW-B03H](#) [D2EW-B03L](#)