

PART NUMBER: CT-1205CL

DESCRIPTION: magnetic buzzer

SPECIFICATIONS

rated voltage	5 V dc	
operating voltage	4 ~ 7 V dc	
current consumption	30 mA max.	
sound output	88 dBA min. (92 typ.)	at a distance of 10 cm (A-weight free air) and 5 V dc
rated frequency	2400 Hz \pm 400 Hz	
operating temperature	-30 ~ +70° C	
storage temperature	-40 ~ +85° C	
dimensions	L12.8 x W12.8 x H7.1 mm	
weight	2.0 g max.	
material	PPS	
terminal	SMD type (Sn Plating)	
RoHS	yes	

APPEARANCE DRAWING

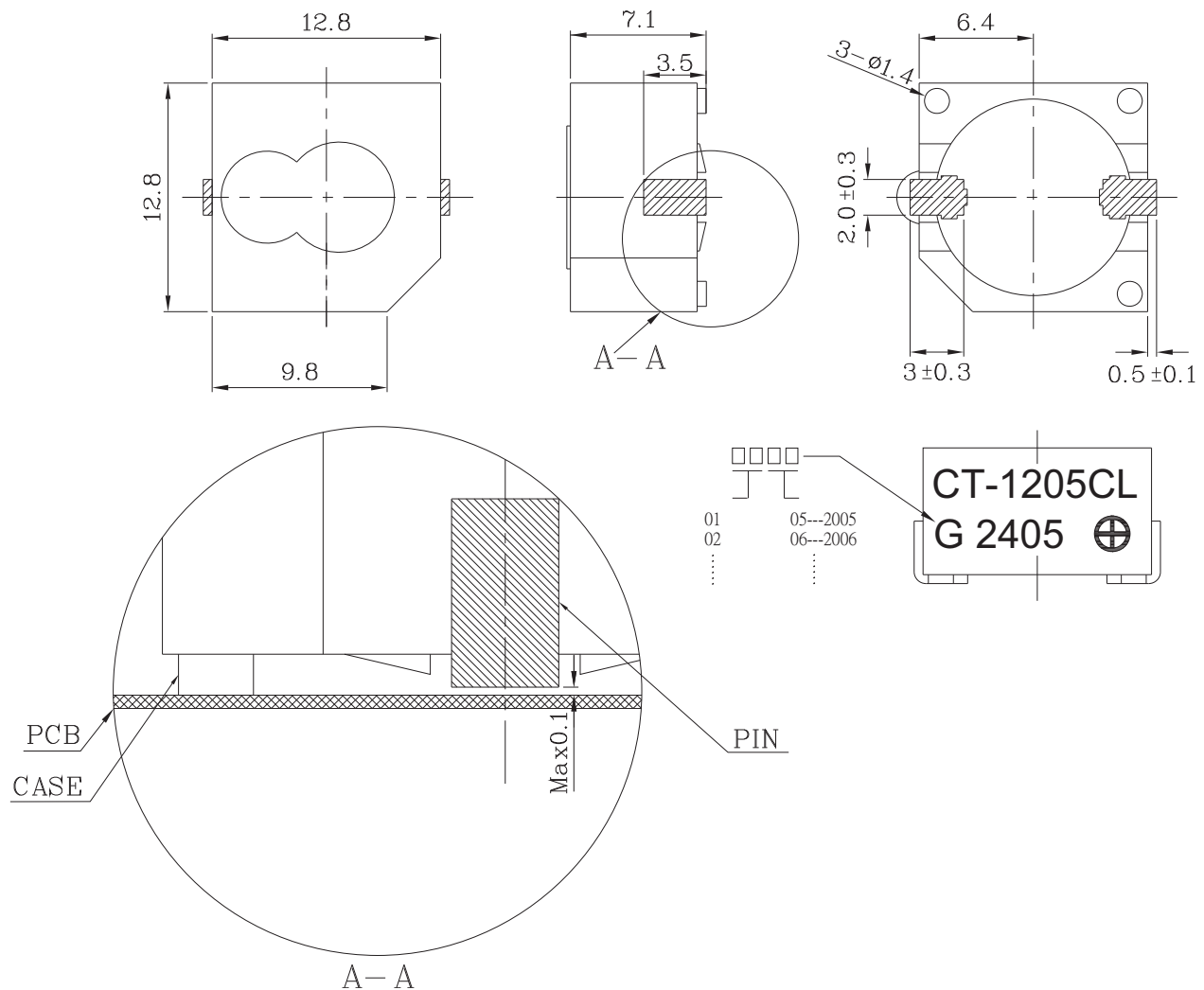
 tolerance: ± 0.5

PART NUMBER: CT-1205CL

DESCRIPTION: magnetic buzzer

VOLTAGE: SOUND PRESSURE LEVEL / CURRENT CONSUMPTION

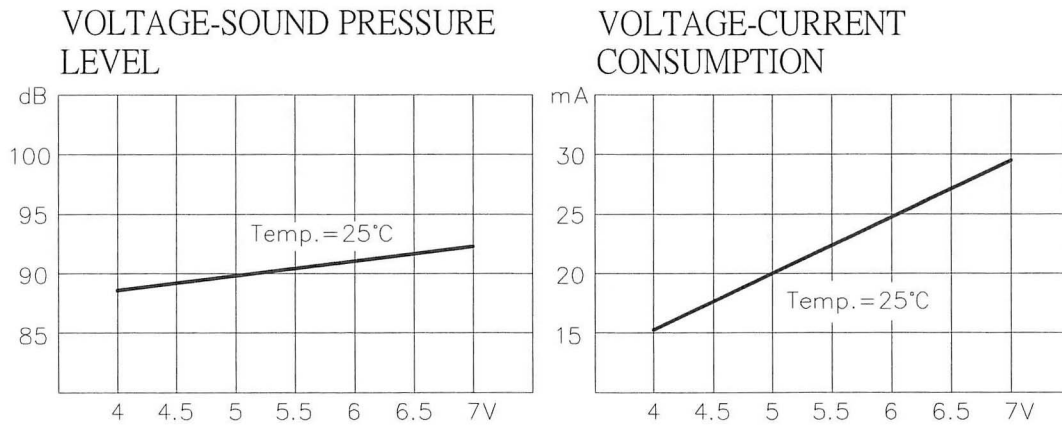

MEASUREMENT METHOD

+V DC

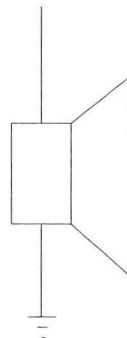

PART NUMBER: CT-1205CL

DESCRIPTION: magnetic buzzer

MECHANICAL CHARACTERISTICS

item	test condition	evaluation standard
solderability	Lead terminals are immersed in solder bath of $270 \pm 5^\circ\text{C}$ for 3 ± 1 seconds.	95% of the surface of the lead pads will be wet with solder.
soldering heat resistance	The product should follow the reflow temperature curve to test its reflow thermo stability.	No interference in operation.
terminal mechanical strength	For 10 seconds, the force of 9.8N (1.0kg) is applied to each terminal in axial direction.	No damage or cutting off.
vibration	The buzzer will be measured after applying a vibration amplitude of 1.5 mm with 10 to 55 Hz band of vibration frequency to each of the 3 perpendicular directions for 2 hours.	After the test, the part will meet specifications without any damage in appearance and the SPL should be within $\pm 10\%$ of the initial measurements.
drop test	The part will be dropped from a height of 75 cm onto a 40 mm thick wooden board 3 times in 3 axes (X, Y, Z) for a total of 9 drops.	

ENVIRONMENT TEST

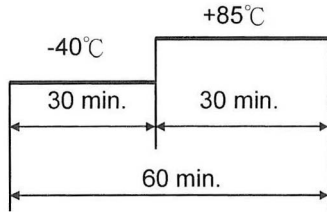
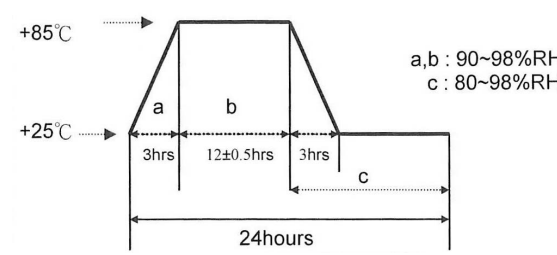
item	test condition	evaluation standard
high temp. test	After being placed in a chamber at $+85^\circ\text{C}$ for 96 hours.	After the test, the part will meet specifications without any damage in appearance except SPL. After 4 hours at 25°C , SPL should be within $\pm 10\%$ of the initial measurements.
low temp. test	After being placed in a chamber at -40°C for 96 hours.	
thermal shock	The part shall be subjected to 10 cycles. One cycle will consist of: <div style="text-align: center;">  </div>	
temp. cycle test	The part shall be subjected to 10 cycles. One cycle will last 24 hours and will consist of: <div style="text-align: center;">  </div>	

PART NUMBER: CT-1205CL

DESCRIPTION: magnetic buzzer

RELIABILITY TEST

item	test condition	evaluation standard
operating (life test)	1. Continuous life test: The part will be subjected to 72 hours of continuous operation at +55°C with 5 V applied. 2. Intermittent life test: A duty cycle of 1 minute on, 1 minute off, a minimum of 10,000 times at room temp (+25 ±10°C) with 5 V dc applied.	After the test, the part will meet specifications without any damage in appearance except SPL. After 4 hours at 25°C, SPL should be within ±10% of the initial measurements.

TEST CONDITIONS

standard test condition	a) temperature: +5 ~ +35°C	b) humidity: 45 - 85%	c) pressure: 860-1060 mbar
judgement test condition	a) temperature: +25 ±2°C	b) humidity: 60 - 70%	c) pressure: 860-1060 mbar

RECOMMENDED TEMPERATURE PROFILE FOR REFLOW OVEN

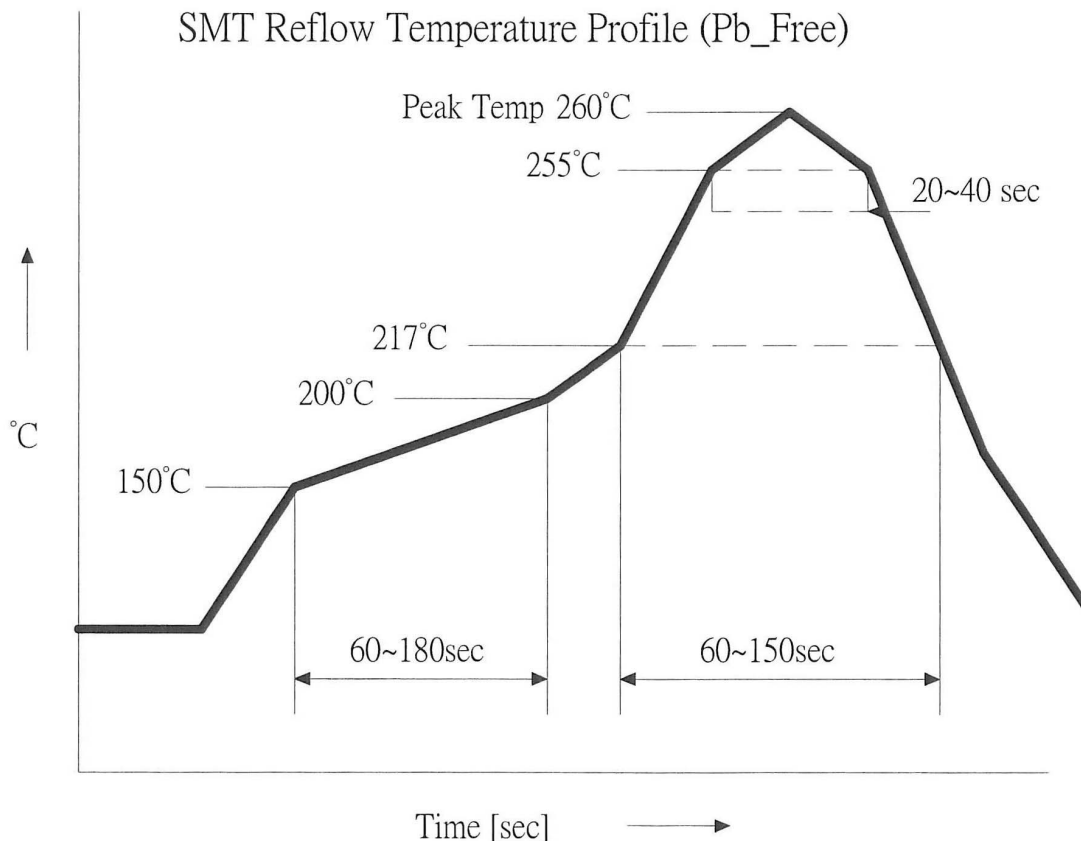

PART NUMBER: CT-1205CL

DESCRIPTION: magnetic buzzer

RECOMMENDED LAND PATTERN

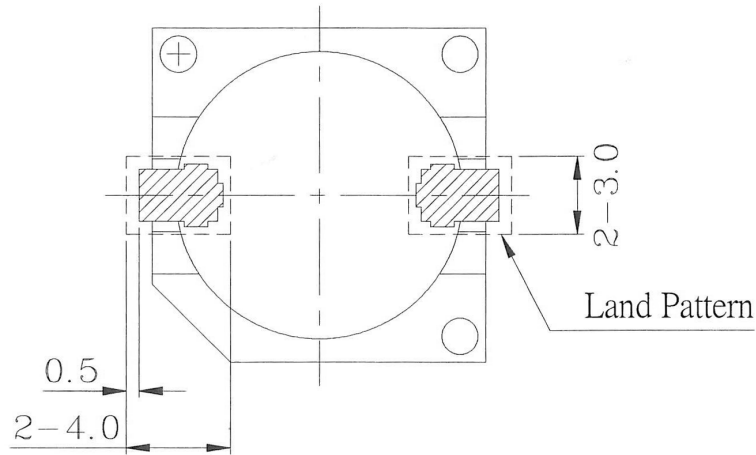

PACKAGING

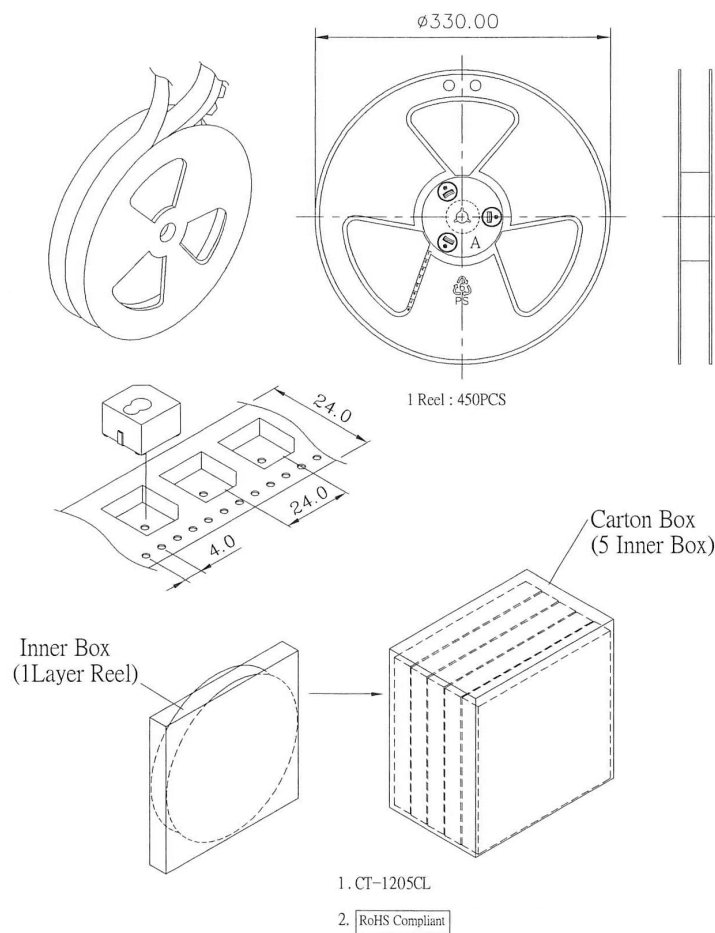

Inner Box	340mmx340mmx40mm	1x450PCS=450PCS
Carton Box	350mmx175mmx355mm	5x450PCS=2,250PCS