

High Voltage Phase Control Thyristor

in High Voltage
ISOPLUS i4-PAC™

$$\begin{aligned}
 V_{\text{DRM}} = V_{\text{RRM}} &= 2200 \text{ V} \\
 I_{\text{T(AV)}} &= 18 \text{ A} \\
 I_{\text{TSM}} &= 200 \text{ A}
 \end{aligned}$$

Part number
CS 20-22moF1

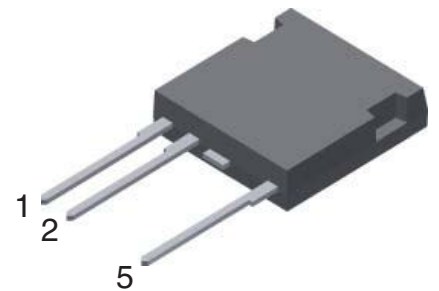
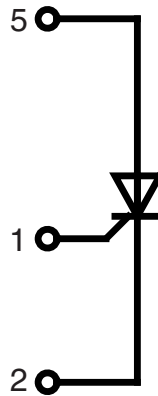

Features / Advantages:

- high voltage thyristor
 - for line frequency
 - chip technology for long term stability
- ISOPLUS i4-PAC™ high voltage package
 - isolated back surface
 - enlarged creepage towards heatsink
 - enlarged creepage between high voltage pins
 - application friendly pinout
 - high reliability
 - industry standard outline

Applications:

- controlled rectifiers
 - power supplies
 - drives
- AC switches
- capacitor discharge control
 - flash tubes
 - X-ray and laser generators

Package: i4-Pac

- Isolation Voltage: 3000 V~
- Industry convenient outline
- RoHS compliant
- Epoxy meets UL 94V-0
- Soldering pins for PCB mounting
- Backside: DCB ceramic
- Reduced weight
- Advanced power cycling

Disclaimer Notice

Information furnished is believed to be accurate and reliable. However, users should independently evaluate the suitability of and test each product selected for their own applications. Littelfuse products are not designed for, and may not be used in, all applications. Read complete Disclaimer Notice at www.littelfuse.com/disclaimer-electronics.

Thyristor			Ratings				
Symbol	Definitions	Conditions	min.	typ.	max.	Unit	
$V_{DRM, RRM}$	<i>max. repetitive blocking voltage</i>				2200	V	
$I_{T(AV)}$	<i>average forward current</i>	sine 180° square; $d = 1/3$			18	A	
$I_{T(AV)}$					16	A	
I_{TSM}	<i>max. surge on-state current</i>	sine 180°; $t = 10$ ms; $V_R = 0$ V			200	A	
$(di/dt)_{cr}$	<i>critical rate of rise of current</i>	$T_{VJ} = T_{VJM}$ $f = 50$ Hz; $t_p = 200$ μ s	repetitive, $I_T = 40$ A			100	A/ μ s
		$V_D = 2/3 V_{DRM}$ $I_G = 0.45$ A $di_G/dt = 0.45$ A/ μ s	non repetitive, $I_T = 20$ A			250	A/ μ s
$(dv/dt)_{cr}$	<i>critical rate of rise of voltage</i>	$T_{VJ} = T_{VJM}$; $V_D = 2/3 V_{DRM}$ $R_{GK} = \infty$; method 1 (linear voltage rise)			2500	V/ μ s	
V_T	<i>forward voltage</i>	$I_T = 20$ A	$T_{VJ} = 25^\circ$ C		1.3	V	
			$T_{VJ} = 125^\circ$ C		1.3	V	
V_{GT}	<i>gate trigger voltage</i>	$V_D = 6$ V	$T_{VJ} = 25^\circ$ C		2.3	V	
I_{GT}	<i>gate trigger current</i>				250	mA	
V_{GD}	<i>gate non-trigger voltage</i>	$V_D = 2/3 V_{DRM}$	$T_{VJ} = 125^\circ$ C		0.2	V	
I_{GD}	<i>gate non-trigger current</i>				5	mA	
I_L	<i>latching current</i>	$t_p = 10$ μ s; $V_D = 6$ V $I_G = 0.45$ A; $di_G/dt = 0.45$ A/ μ s	$T_{VJ} = 25^\circ$ C		500	mA	
I_H	<i>holding current</i>	$V_D = 6$ V; $R_{GK} = \infty$	$T_{VJ} = 25^\circ$ C		150	mA	
t_{gd}	<i>gate controlled delay time</i>	$V_D = 1/2 V_{DRM}$ $I_G = 0.45$ A; $di_G/dt = 0.45$ A/ μ s	$T_{VJ} = 25^\circ$ C	2		μ s	
I_R	<i>reverse current</i>	$V_R = V_{RRM}$; $V_D = V_{DRM}$	$T_{VJ} = 25^\circ$ C		50	μ A	
I_D	<i>drain current</i>		$T_{VJ} = 125^\circ$ C	2		mA	
R_{thJC}	<i>thermal resistance junction to case</i>	DC current			0.92	K/W	
R_{thCH}	<i>thermal resistance case to heatsink</i>	DC current		0.15		K/W	

Package I4-Pac			Ratings			
Symbol	Definitions	Conditions	min.	typ.	max.	Unit
I_{RMS}	RMS current	per terminal			70	A
T_{VJ}	virtual junction temperature		-40		150	°C
T_{op}	operation temperature		-40		125	°C
T_{stg}	storage temperature		-40		150	°C
Weight				5.5		g
F_c	mounting force with clip		20		120	N
$d_{Spp/App}$ $d_{Spb/Apb}$	creepage distance on surface striking distance through air	terminal to terminal terminal to backside	7.2 5.1			mm mm
V_{ISOL}	isolation voltage	t = 1 second t = 1 minute	3000 2500			V V
			50/60 Hz, RMS, $I_{ISOL} \leq 1$ mA			

Product Marking

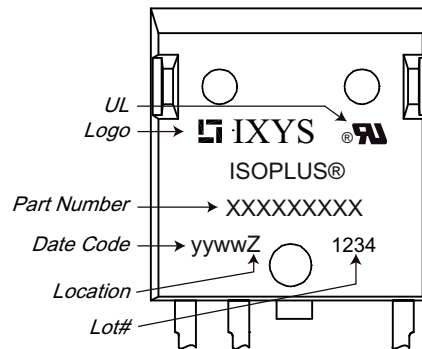

Dimensions in mm (1 mm = 0.0394")

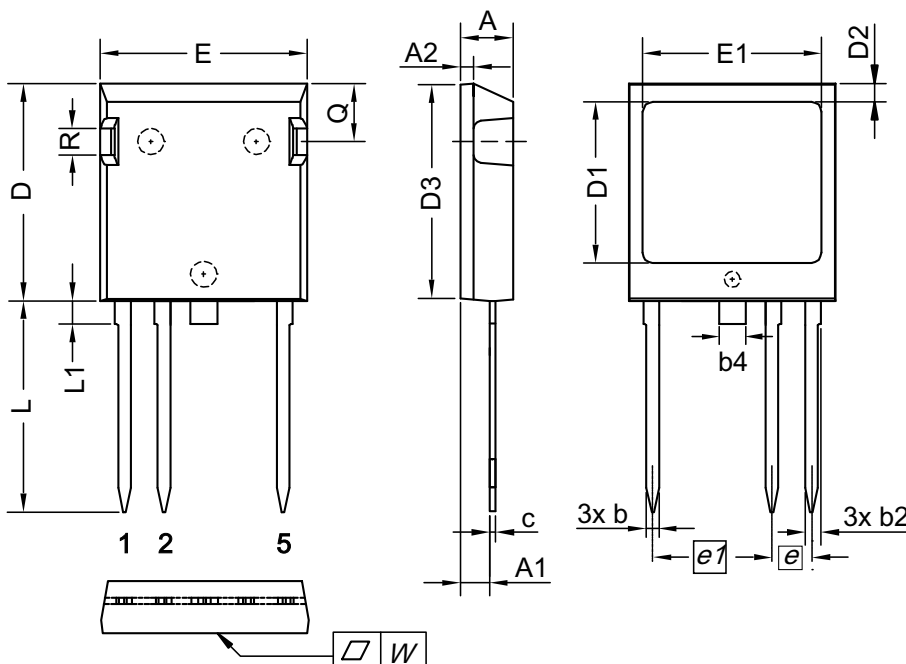

Dim.	Millimeter		Inches	
	min	max	min	max
A	4.83	5.21	0.190	0.205
A1	2.59	3.00	0.102	0.118
A2	1.17	2.16	0.046	0.085
b	1.14	1.40	0.045	0.055
b2	1.47	1.73	0.058	0.068
b4	2.54	2.79	0.100	0.110
c	0.51	0.74	0.020	0.029
D	20.80	21.34	0.819	0.840
D1	14.99	15.75	0.590	0.620
D2	1.65	2.03	0.065	0.080
D3	20.30	20.70	0.799	0.815
E	19.56	20.29	0.770	0.799
E1	16.76	17.53	0.660	0.690
e	3.81 BSC		0.150 BSC	
e1	11.43 BSC		0.450 BSC	
L	19.81	21.34	0.780	0.840
L1	2.11	2.59	0.083	0.102
Q	5.33	6.20	0.210	0.244
R	2.54	4.57	0.100	0.180
W	-	0.10	-	0.004

Die konvexe Form des Substrates ist typ. < 0.05 mm über der Kunststoffoberfläche der Bauteilunterseite
 The convexbow of substrate is typ. < 0.05 mm over plastic surface level of device bottom side