

CRD600DA12E-XM3

600 kW High Performance Dual Three Phase Reference Design with Six CAB450M12XM3 1200 V, 450 A SiC Half Bridge Modules + Six CGD12HBXMP Gate Drivers

Technical Features

- Optimized for Cree’s [All-SiC, Low Inductance, Conduction Optimized XM3 Power Module](#)
- Complete Stackup, including: Modules, Cooling, Bussing, Gate Drivers, Voltage / Current Sensors, and Controller
- High-Frequency, Ultra-Fast Switching Operation with Ultra-Low Loss, Low Parasitic Bussing

System Benefits

- Enables Compact, Lightweight Systems
- Increased Power Density
- High Efficiency Operation
- Reduced Thermal Requirements
- Reduced System Cost

Applications

- High Power Density New Product Development
- High Frequency Converter Applications
- Vehicle Traction Inverters
- Active Front Ends
- Uninterruptible Power Supplies
- Industrial Motor Drives
- Energy Storage
- Grid-Tied Distributed Generation: Solar and Wind
- Smart-Grid / Flexible AC Transmission Systems

Package



Maximum Ratings (T_c = 25 °C unless otherwise specified)

Symbol	Parameter	Value	Unit	Test Conditions
V _{DSmax}	Maximum Drain-Source Voltage	1200	V	
V _{DC}	DC Bus Voltage, Maximum	900		
	DC Bus Voltage, Recommended	800		
I _{DC}	DC Bus Current Ripple, Maximum	325	A	T _A = 40 °C at 40 kHz (Set by capacitor rating)

Electrical System Ratings ($T_c = 25^\circ\text{C}$ unless otherwise specified)

Symbol	Parameter	Min.	Typ.	Max.	Unit	Test Conditions
$I_{\phi(rms)}$	AC Output Phase Current (RMS), per phase		360 ¹		A	$V_{AC,out} = 480 V_{rms}$ WEG coolant, 50% blend, 24 L/min., $f_{sw} = 20$ kHz, $V_{DC} = 800 V$, $f_{out} = 300$ Hz, DPF = 1.0, $T_{coolant} = 25^\circ\text{C}$, $T_a = 25^\circ\text{C}$
	AC Output Phase Current (RMS), paralleled two phases		720 ²			
f_{sw}	Switching Frequency		20	80	kHz	Based on gate drive power
f_{out}	Fundamental Output Frequency			550	Hz	Controller limited
C_{DC}	DC Bus Capacitor Bank Capacity		600		μF	120 Hz
L_{DC}	DC Bus Capacitor Bank ESL		13	15	nH	
R_{DC}	DC Bus Capacitor Bank ESR		1		m Ω	10 kHz

- 1 Independent operation such as dual inverter, or back to back rectifier/inverter
- 2 Parallel operation of two phases

Environmental Ratings

Symbol	Parameter	Min.	Typ.	Max.	Unit	Test Conditions
T_a	Ambient Temperature		25	40	$^\circ\text{C}$	Higher ambient temperature possible with power derating.
$T_{coolant}$	Coolant Temperature		25	90		Switching frequency and phase current must be selected as to not exceed $T_{J,Max}$.
T_{stg}	Storage Temperature	-40		85		
	Installation Altitude			2000	m	Without voltage derating

Thermal & Mechanical Characteristics

Symbol	Parameter	Min.	Typ.	Max.	Unit	Test Conditions
A	Area		546		cm^2	
W	Weight		9.7		kg	
V	Volume		8.6		L	
P	Coolant Operating Pressure			5	bar	
Δp	Pressure Drop		200		mbar	24 L/min, $T_{coolant} = 25^\circ\text{C}$
	Mounting Torque		11.0		N-m	AC & DC Terminals, M10 bolts
		2.0	4.0	5.0		Module Power Terminals M5 Bolts
		2.0	3.0	4.0		Module Baseplate M4 Bolts

Performance References

- All datasheet ratings should be respected for all included components. Refer to the component datasheets for further information.
- For information on the integrated modules, please reference the [CAB450M12XM3 datasheet](#).
- For information on the integrated gate drivers, please reference the [CGD12HBXMP datasheet](#).
- For higher ambient temperatures, the DC-Link voltage and DC-Link current must be de-rated according to the included DC-Link capacitor ratings. Please refer to the 900 V / 100 μ F UP9-31204K provided by Electronic Concepts, Inc. for more detailed information.
- The included cold plate is a Wieland® MicroCool® CP4012D-XP. In order to calculate the thermal resistance ($^{\circ}$ C/W) and pressure drop (bar) versus flow rate (liters/min.), please refer to the [CP4012D-XP datasheet](#) provided by Wieland MicroCool Inc. for more detailed information.

Controller Connections

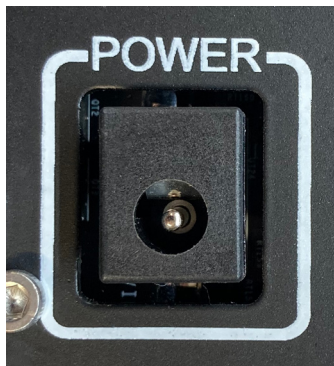

Controller input power supply input utilizes a CUI® PJ-015AH-SMT-TR barrel jack connector.

Pin Number	Name	Type	Description
Center	+12V	PWR	+12V Input Power
Sleeve	Ground	-	Controller Ground



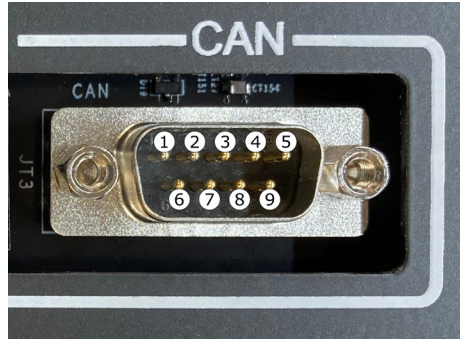

Isolated CAN port utilizes a Amphenol® L777TSEG09POL2RM8 male DE-9 connector.

Pin Number	Name	Type	Description
1	NC	-	NO CONNECT
2	CANA-L	I/O	Isolated CAN Port A Low
3	GND-1	-	Isolated Ground
4	NC	-	NO CONNECT
5	GND-1	-	Isolated Ground
6	NC	-	NO CONNECT
7	CANA-H	I/O	Isolated CAN Port A High
8	NC	-	NO CONNECT
9	+5V-ISO	PWR	Isolated +5V Power Supply Output

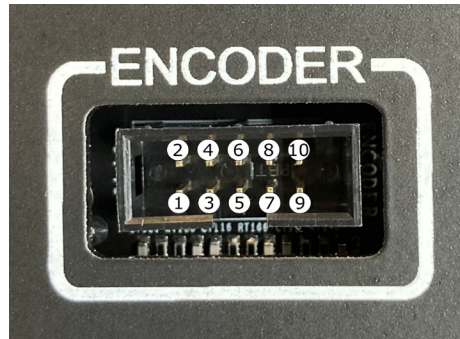

Encoder port utilizes a Sullins® SBH11-PBPC-D05-ST-BK 2.54mm pitch header with 10 pins.

Pin Number	Name	Type	Description
1	QEPA-A	I	Quadrature Encoder Port A Input A
2	QEPA-B	I	Quadrature Encoder Port A Input B
3	QEPA-I	I	Quadrature Encoder Port A Input I
4	+5V	PWR	+5V Power Supply Output
5	GND	PWR	Controller Ground
6	QEPB-A	I	Quadrature Encoder Port B Input A
7	QEPB-B	I	Quadrature Encoder Port B Input B
8	QEPB-I	I	Quadrature Encoder Port B Input I
9	+5V	PWR	+5V Power Supply Output
10	GND	PWR	Controller Ground



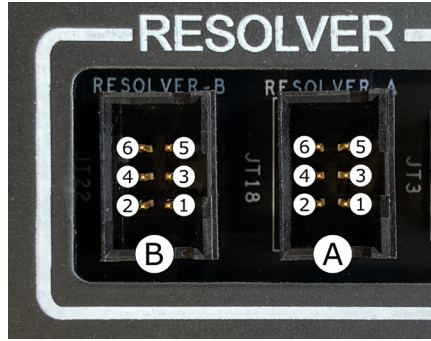

Resolver A port utilizes a Würth® 61200621621 2.54mm pitch header with 6 pins.

Pin Number	Name	Type	Description
1	EXC-A-P	O	Positive Excitation Output
2	EXC-A-N	O	Negative Excitation Output
3	SIN-A-P	I	Positive Sine Input
4	SIN-A-N	I	Negative Sine Input
5	COS-A-P	I	Positive Cosine Input
6	COS-A-N	I	Negative Cosine Input

Resolver B port utilizes a Würth® 61200621621 2.54mm pitch header with 6 pins.

Pin Number	Name	Type	Description
1	EXC-B-P	O	Positive Excitation Output
2	EXC-B-N	O	Negative Excitation Output
3	SIN-B-P	I	Positive Sine Input
4	SIN-B-N	I	Negative Sine Input
5	COS-B-P	I	Positive Cosine Input
6	COS-B-N	I	Negative Cosine Input





Auxiliary controller connector utilizes Sullins® SBH11-PBPC-D10-ST-BK connector.

Pin Number	Name	Type	Description
1	12V	PWR	+12 V Power Supply Output
2	GND	PWR	Controller Ground
3	SPIA-MOSI	I/O	GPIO16 SPISIMOA (I/O) CANTXB (O) OUTPUTXBAR7 (O) EPWM9A (O) SD1_D1 (I) UPP-D4 (I/O)
4	SPIA-STE	I/O	GPIO19 SPISTEA (I/O) SCIRXDB (I) CANTXA (O) EPWM10B (O) SD1_C2 (I) UPP-D1 (I/O)
5	SPIA-MISO	I/O	GPIO17 SPISOMIA (I/O) CANRXB (I) OUTPUTXBAR8 (O) EPWM9B (O) SD1_C1 (I) UPP-D3 (I/O)
6	SPIA-CLK	I/O	GPIO18 SPICLKA (I/O) SCITXDB (O) CANRXA (I) EPWM10A (O) SD1_D2 (I) UPP-D2 (I/O)
7	3.3V	PWR	+3.3 V Power Supply Output
8	GND	PWR	Controller Ground
9	I2CA-SCL	I/O	GPIO33 SCLA (I/OD) EM1RNW (O)
10	I2CA-SDA	I/O	GPIO32 SDAA (I/OD) EM1CS0 (O)
11	PWM7B	I/O	GPIO13 EPWM7B (O) CANRXB (I) MDRB (I) EQEP1I (I/O) SCIRXDC (I) UPP-D7 (I/O)
12	PWM7A	I/O	GPIO12 EPWM7A (O) CANTXB (O) MDXB (O) EQEP1S (I/O) SCITXDC (O) UPP-ENA (I/O)
13	PWM8B	I/O	GPIO15 EPWM8B (O) SCIRXDB (I) MFSXB (I/O) OUTPUTXBAR4 (O) UPP-D5 (I/O)
14	PWM8A	I/O	GPIO14 EPWM8A (O) SCITXDB (O) MCLKXB (I/O) OUTPUTXBAR3 (O) UPP-D6 (I/O)
15	SD-C1	I/O	GPIO49 OUTPUTXBAR4 (O) EM1A9 (O) SCIRXDA (I) SD1_C1 (I)
16	SD-D1	I/O	GPIO48 OUTPUTXBAR3 (O) EM1A8 (O) SCITXDA (O) SD1_D1 (I)
17	SD-C2	I/O	GPIO51 EQEP1B (I) EM1A11 (O) SPISOMIC (I/O) SD1_C2 (I)
18	SD-D2	I/O	GPIO50 EQEP1A (I) EM1A10 (O) SPISIMOC (I/O) SD1_D2 (I)
19	SD-C3	I/O	GPIO53 EQEP1I (I/O) EM1D31 (I/O) EM2D15 (I/O) SPISTEC (I/O) SD1_C3 (I)
20	SD-D3	I/O	GPIO52 EQEP1S (I/O) EM1A12 (O) SPICLKC (I/O) SD1_D3 (I)

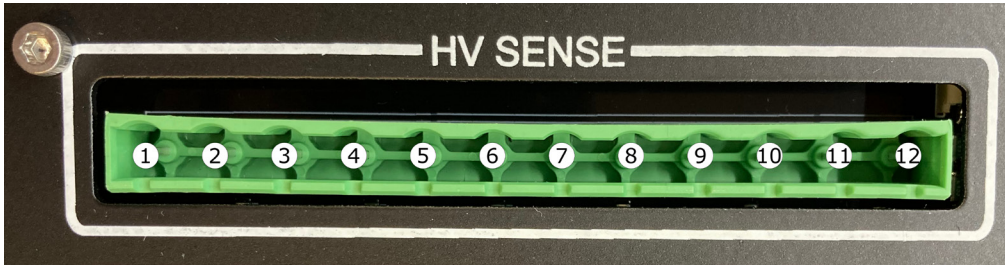

The voltage sensor input utilizes a Phoenix Contact® 1766877 connector. Example mating connector 1832620.

Pin Number	Name	Type	Description
1	V_Z-	I	Negative High-Voltage Measurement Input Phase Z
2	V_Z+	I	Positive High-Voltage Measurement Input Phase Z
3	V_Y-	I	Negative High-Voltage Measurement Input Phase Y
4	V_Y+	I	Positive High-Voltage Measurement Input Phase Y
5	V_X-	I	Negative High-Voltage Measurement Input Phase X
6	V_X+	I	Positive High-Voltage Measurement Input Phase X
7	V_W-	I	Negative High-Voltage Measurement Input Phase W
8	V_W+	I	Positive High-Voltage Measurement Input Phase W
9	V_V-	I	Negative High-Voltage Measurement Input Phase V
10	V_V+	I	Positive High-Voltage Measurement Input Phase V
11	V_U-	I	Negative High-Voltage Measurement Input Phase U
12	V_U+	I	Positive High-Voltage Measurement Input Phase U

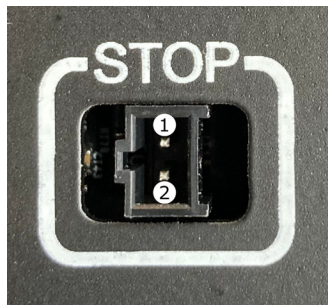

The ESTOP input utilizes a Samtec® IPL1-102-01-F-S-K connector. Example mating connector IPD1-02-S-K.

Pin Number	Name	Type	Description
1	STOP	I	ESTOP Input
2	GND	PWR	Controller Ground



Performance References

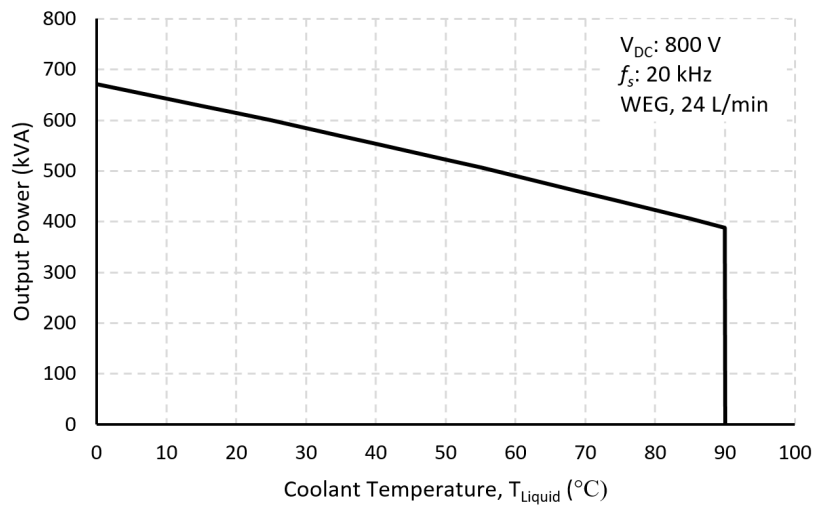

Figure 1. Output Power vs. Coolant Temperature

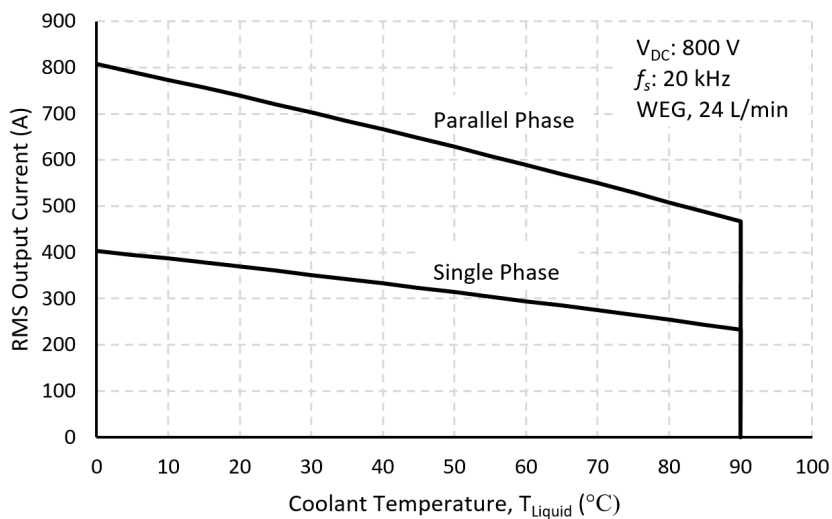
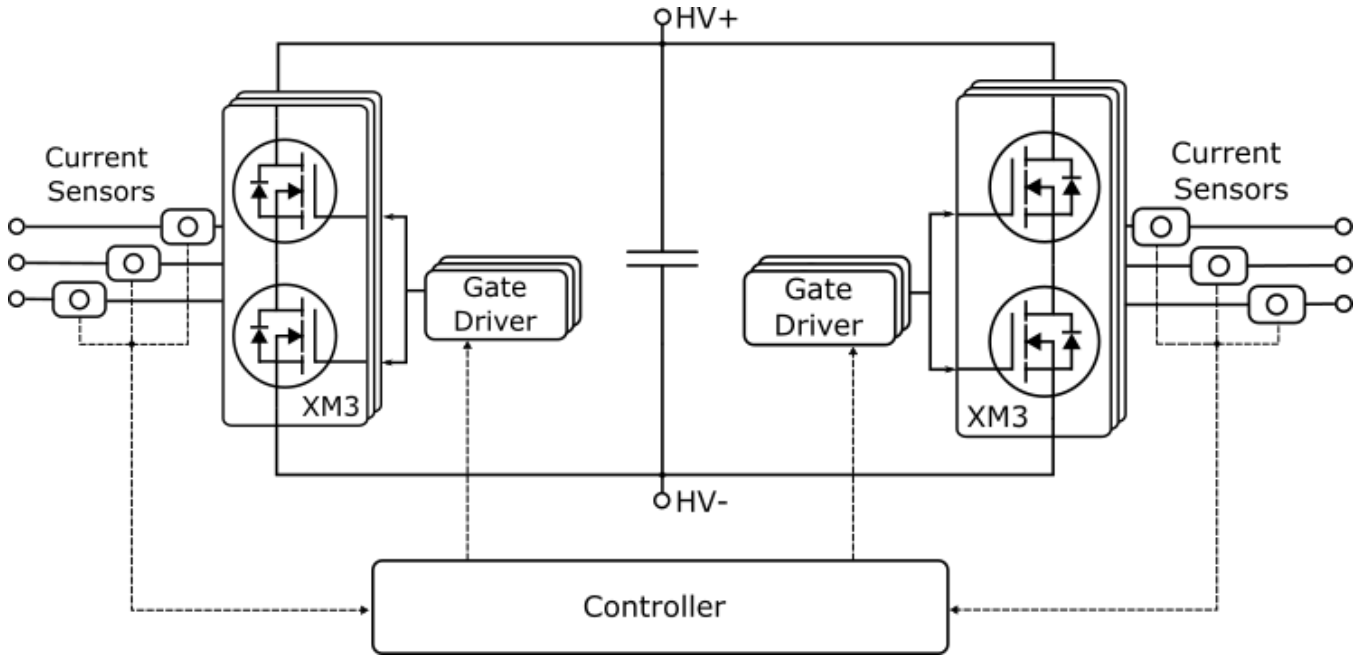

Figure 2. Output Current vs. Coolant Temperature



System Diagram



Full circuit schematics provided upon delivery of the reference design.

Power Connections

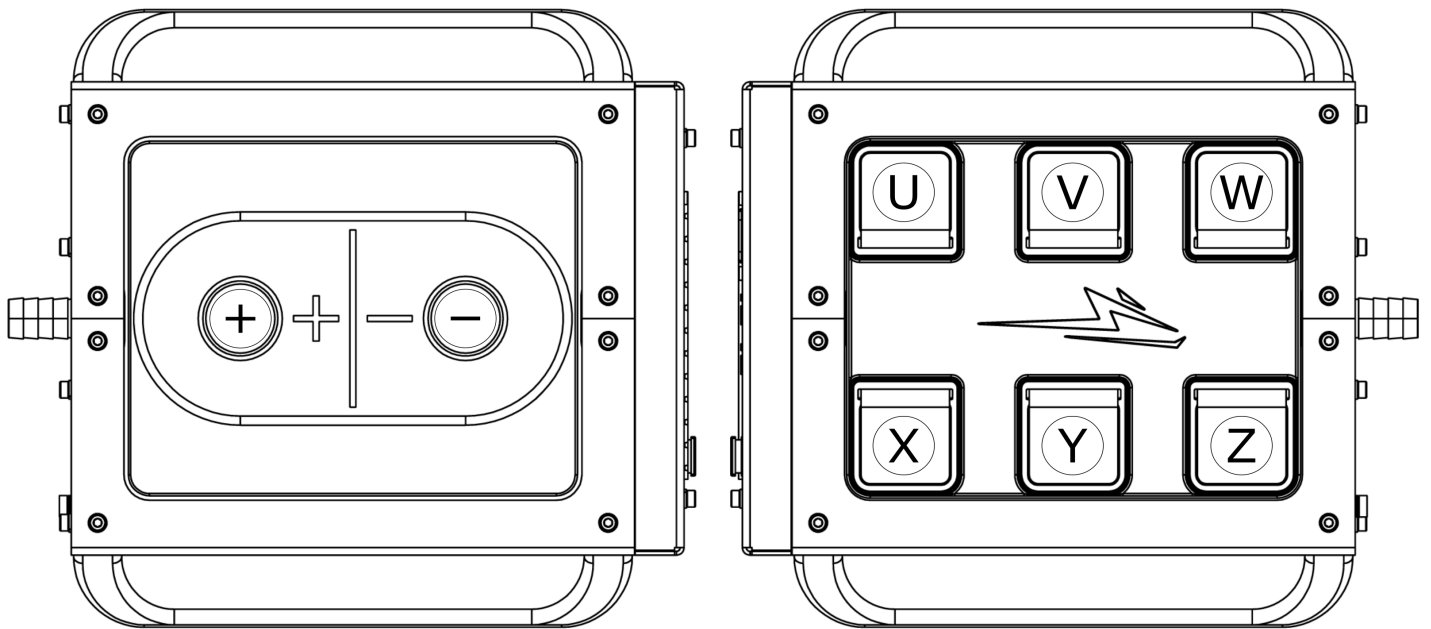

Package Dimensions (mm)

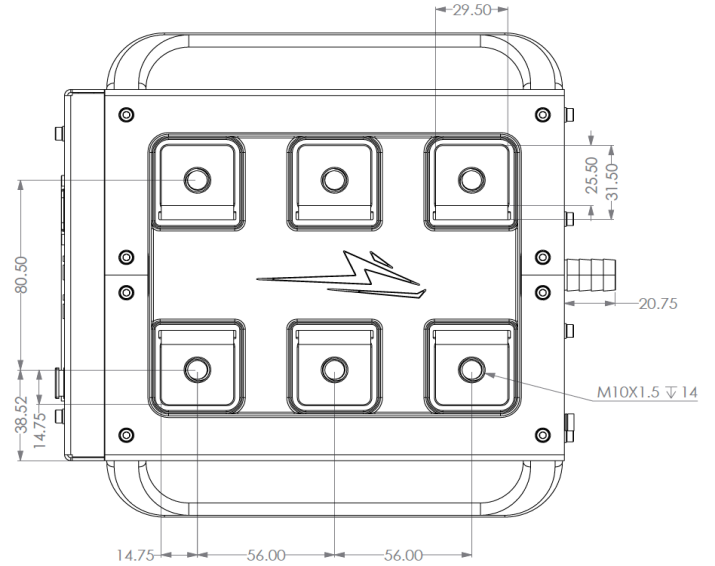
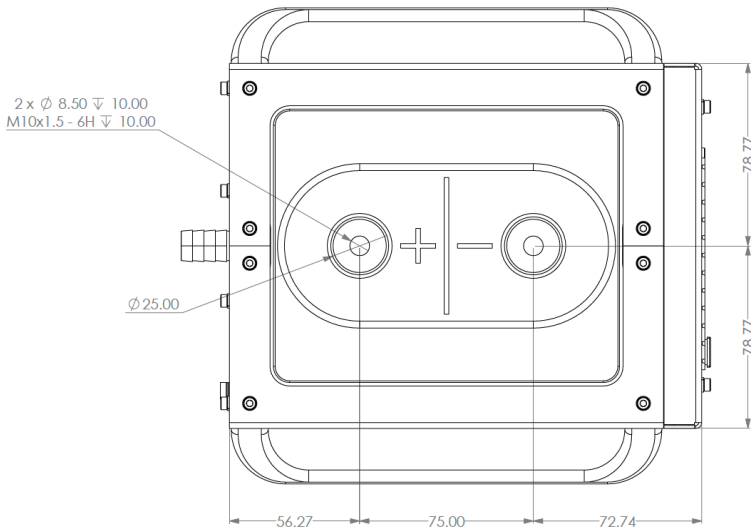
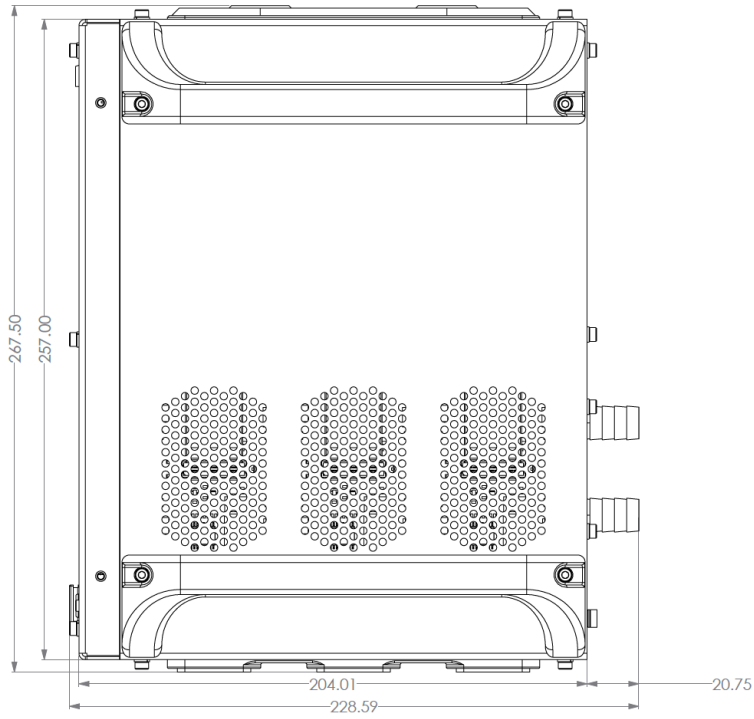

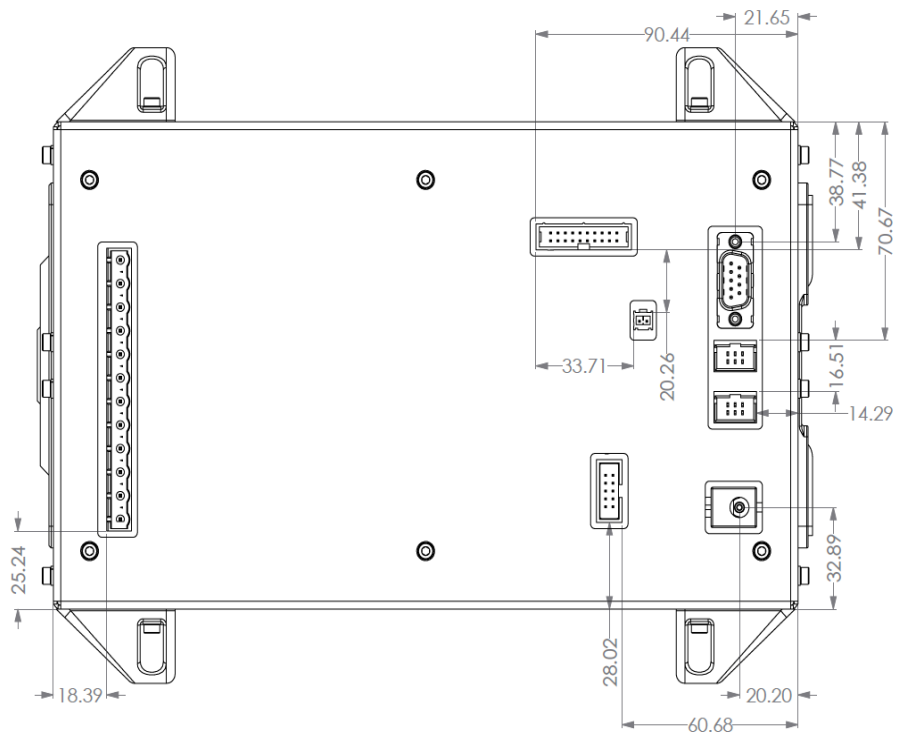
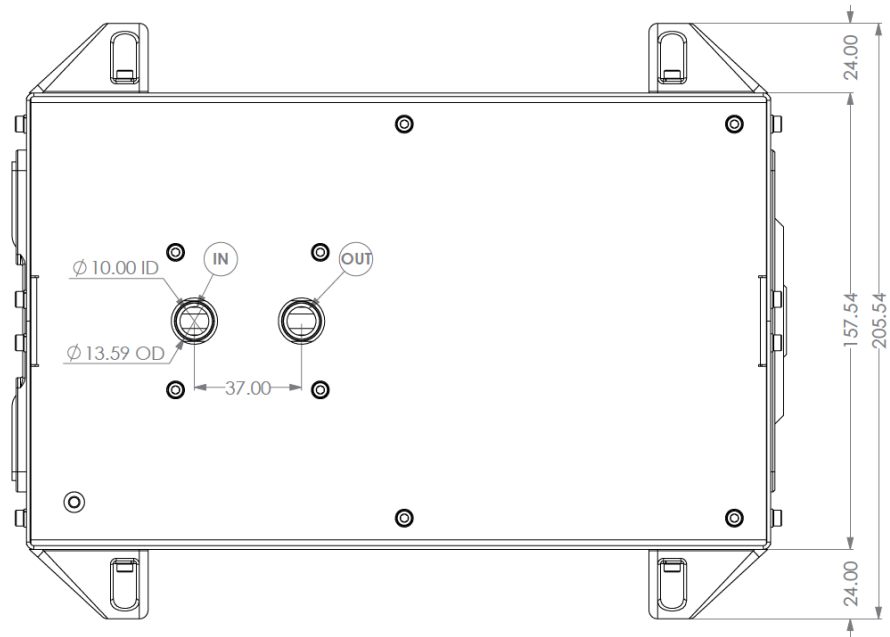

Supporting Links & Tools

- [CAB450M12XM3: 1200 V, 450 A SiC Half-Bridge Module](#)
- [CGD12HBXMP: XM3 Evaluation Gate Driver](#)
- [CGD12HB00D: Differential Transceiver Board for CGD12HBXMP](#)
- [CRD300DA12E-XM3: 300 kW Inverter Kit for Conduction-Optimized XM3 \(CPWR-AN30\)](#)
- [KIT-CRD-CIL12N-XM3: Dynamic Performance Evaluation Board for the XM3 Module \(CPWR-AN31\)](#)
- [CPWR-AN28: Module Mounting Application Note](#)
- [CPWR-AN29: Thermal Interface Material Application Note](#)

Important Notes

- This Cree-designed reference design hardware for Cree components is meant to be used as an evaluation tool in a lab setting and to be handled and operated by highly qualified technicians or engineers. The hardware is not designed to meet any particular safety standards and the tool is not a production qualified assembly.
- Each part that is used in this reference design and is manufactured by an entity other than Cree or one of Cree's affiliates is provided "as is" without warranty of any kind, including but not limited to any warranty of non-infringement, merchantability, or fitness for a particular purpose, whether express or implied. There is no representation that the operation of each such part will be uninterrupted or error free.
- This document and the information contained herein are subject to change without notice. Any such change shall be evidenced by the publication of an updated version of this document by Cree. No communication from any employee or agent of Cree or any third party shall effect an amendment or modification of this document. No responsibility is assumed by Cree for any infringement of patents or other rights of third parties which may result from use of the information contained herein. No license is granted by implication or otherwise under any patent or patent rights of Cree.
- Notwithstanding any application-specific information, guidance, assistance, or support that Cree may provide, the buyer of this product is solely responsible for determining the suitability of this product for the buyer's purposes, including without limitation for use in the applications identified in the next bullet point, and for the compliance of the buyers' products, including those that incorporate this product, with all applicable legal, regulatory, and safety-related requirements.
- This product has not been designed or tested for use in, and is not intended for use in, applications in which failure of the product would reasonably be expected to cause death, personal injury, or property damage, including but not limited to equipment implanted into the human body, life-support machines, cardiac defibrillators, and similar emergency medical equipment, aircraft navigation, communication, and control systems, aircraft power and propulsion systems, air traffic control systems, and equipment used in the planning, construction, maintenance, or operation of nuclear facilities.
- The SiC MOSFET module switches at speeds beyond what is customarily associated with IGBT-based modules. Therefore, special precautions are required to realize optimal performance. The interconnection between the gate driver and module housing needs to be as short as possible. This will afford optimal switching time and avoid the potential for device oscillation. Also, great care is required to insure minimum inductance between the module and DC link capacitors to avoid excessive VDS overshoot.