

CRD200DA12E-XM3

200 kW High Performance Three Phase Reference Design with Three CAB400M12XM3 1200 V, 400 A SiC Half Bridge Modules + Three CGD12HBXMP Gate Drivers

Technical Features

- Optimized for Cree’s [All-SiC, Low Inductance, Switching-Loss Optimized XM3 Power Module](#)
- Complete Stackup, including: Modules, Cooling, Bussing, Gate Drivers, Voltage / Current Sensors, and Controller
- High-Frequency, Ultra-Fast Switching Operation with Ultra-Low Loss, Low Parasitic Bussing

System Benefits

- Enables Compact, Lightweight Systems
- Increased Power Density
- High Efficiency Operation
- Reduced Thermal Requirements
- Reduced System Cost

Applications

- High Power Density New Product Development
- High Frequency Converter Applications
- Vehicle Traction Inverters
- Active Front Ends
- Uninterruptible Power Supplies
- Industrial Motor Drives
- Energy Storage
- Grid-Tied Distributed Generation: Solar and Wind
- Smart-Grid / Flexible AC Transmission Systems

Package



Maximum Ratings (T_c = 25 °C unless otherwise specified)

Symbol	Parameter	Value	Unit	Test Conditions
V _{DSmax}	Maximum Drain-Source Voltage	1200	V	
V _{DC}	DC Bus Voltage, Maximum	900		
	DC Bus Voltage, Recommended	800		
I _{DC}	DC Bus Current Ripple, Maximum	300	A	T _A = 30 °C at 10 kHz (Set by capacitor rating)



Electrical System Ratings ($T_c = 25^\circ\text{C}$ unless otherwise specified)

Symbol	Parameter	Min.	Typ.	Max.	Unit	Test Conditions
$I_{\phi(rms)}$	AC Output Phase Current (RMS)		240		A	$V_{AC,out} = 480 V_{rms}$ WEG coolant, 50% blend, 12 L/min., $f_{sw} = 10\text{ kHz}$, $V_{DC} = 800\text{ V}$, $f_{out} = 300\text{ Hz}$, DPF = 1.0, $T_{coolant} = 25^\circ\text{C}$, $T_a = 25^\circ\text{C}$
f_{sw}	Switching Frequency		20	80	kHz	Based on gate drive power
f_{out}	Fundamental Output Frequency			550	Hz	Controller limited
C_{DC}	DC Bus Capacitor Bank Capacity		300		μF	10 kHz
L_{DC}	DC Bus Capacitor Bank ESL		3.5		nH	
R_{DC}	DC Bus Capacitor Bank ESR		0.4		m Ω	10 kHz
L_{σ}	DC Bus Stray Inductance		1.8		nH	

Environmental Ratings

Symbol	Parameter	Min.	Typ.	Max.	Unit	Test Conditions
T_a	Ambient Temperature		25	40	$^\circ\text{C}$	Higher ambient temperature possible with power derating.
$T_{coolant}$	Coolant Temperature		25	90		Switching frequency and phase current must be selected as to not exceed $T_{J,Max}$.
T_{stg}	Storage Temperature	-40		85		
	Installation Altitude			2000	m	Without voltage derating

Thermal & Mechanical Characteristics

Symbol	Parameter	Min.	Typ.	Max.	Unit	Test Conditions
A	Area		812		cm^2	
W	Weight		6.2		kg	
V	Volume		9.3		L	
P	Coolant Operating Pressure			5	bar	
Δp	Pressure Drop		200		mbar	12 L/min, $T_{coolant} = 25^\circ\text{C}$
	Mounting Torque		11.0		N-m	AC & DC Terminals, M10 bolts
		2.0	4.0	5.0		Module Power Terminals M5 Bolts
		2.0	3.0	4.0		Module Baseplate M4 Bolts



Performance References

- For information on the integrated modules, please reference the [CAB400M12XM3 datasheet](#).
- For information on the integrated gate drivers, please reference the [CGD12HBXMP datasheet](#).
- For higher ambient temperatures, the DC-Link voltage and DC-Link current must be de-rated according to the included DC-Link capacitor ratings. Please refer to the 1100 V / 100 μ F [CX100 \$\mu\$ 1100d51KF6 datasheet](#) provided by FTCAP GmbH for more detailed information.
- The included cold plate is a Wieland® MicroCool® CP3012-XP. In order to calculate the thermal resistance ($^{\circ}$ C/W) and pressure drop (bar) versus flow rate (liters/min.), please refer to the [CP3012-XP datasheet](#) provided by Wieland MicroCool Inc. for more detailed information.
- The included current sensor board uses the LEM® LF 510-S. Please refer to the [LF 510-S datasheet](#) provided by LEM USA Inc. for more detailed information.

Controller Connections

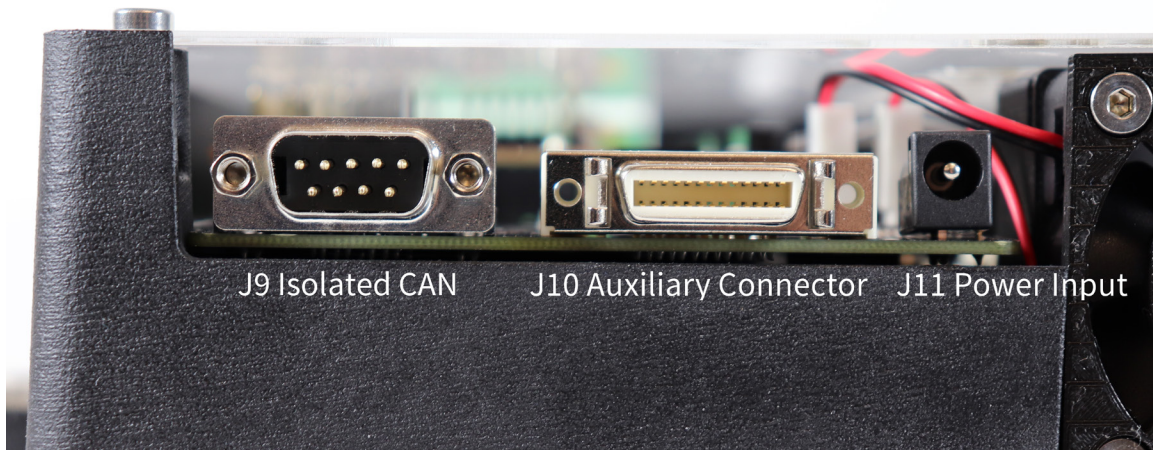

Controller input power supply input utilizes a CUI® PJ-102AH barrel jack connector.

Pin Number	Name	Type	Description
Center	+12V	PWR	+12V Input Power
Sleeve	Ground	-	Controller Ground

Isolated CAN port utilizes a NorComp® 182-009-113R181 male DE-9 connector.

Pin Number	Name	Type	Description
1	NC	-	NO CONNECT
2	CANA-L	I/O	Isolated CAN Port A Low
3	GND-1	-	Isolated Ground
4	NC	-	NO CONNECT
5	GND-1	-	Isolated Ground
6	NC	-	NO CONNECT
7	CANA-H	I/O	Isolated CAN Port A High
8	NC	-	NO CONNECT
9	+5V-ISO	PWR	Isolated +5V Power Supply Output



Auxiliary controller connector utilizes 3M® 10226-55G3PC connector.

Pin Number	Name	Type	Description
1	CANBL	I/O	Non-isolated CAN port B Low
2	CANBH	I/O	Non-isolated CAN port B High
3	GND	-	Controller Ground
4	GND	-	Controller Ground
5	GND	-	Controller Ground
6	IEXT-m	I	External Current Sensor Signal
7	-15V	PWR	External Current Sensor Power -15V
8	+15V	PWR	External Current Sensor Power +15V
9	GND	-	Controller Ground
10	+3V3	PWR	+3.3V Power Supply Output
11	GND	-	Controller Ground
12	+5V	PWR	+5V Power Supply Output
13	GND	PWR	Controller Ground
14	QEA_A	I	Quadrature Encoder Port A Input A
15	GND	-	Controller Ground
16	QEA_B	I	Quadrature Encoder Port A Input B
17	GND	-	Controller Ground
18	QEA_I	I	Quadrature Encoder Port A Input I
19	GND	-	Controller Ground
20	+5V	PWR	+5V Power Supply Output
21	GND	-	Controller Ground
22	QEB_A	I	Quadrature Encoder Port B Input A
23	GND	-	Controller Ground
24	QEB_B	I	Quadrature Encoder Port B Input B
25	GND	-	Controller Ground
26	QEB_I	I	Quadrature Encoder Port B Input I



The voltage sensor input utilizes a Phoenix Contact® 1719231 connector.

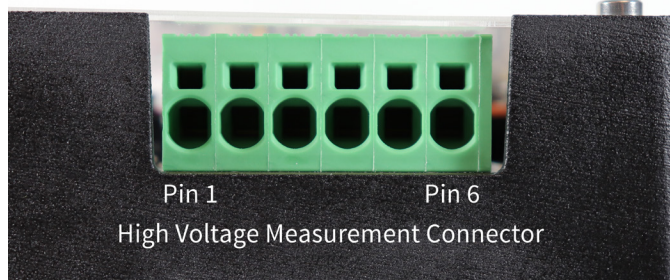

Pin Number	Name	Type	Description
1	VA-P	I	Positive High-Voltage Measurement Input Phase A
2	VA-M	I	Negative High-Voltage Measurement Input Phase A
3	VB-P	I	Positive High-Voltage Measurement Input Phase B
4	VB-M	I	Negative High-Voltage Measurement Input Phase B
5	VC-P	I	Positive High-Voltage Measurement Input Phase C
6	VC-M	I	Negative High-Voltage Measurement Input Phase C

Performance References

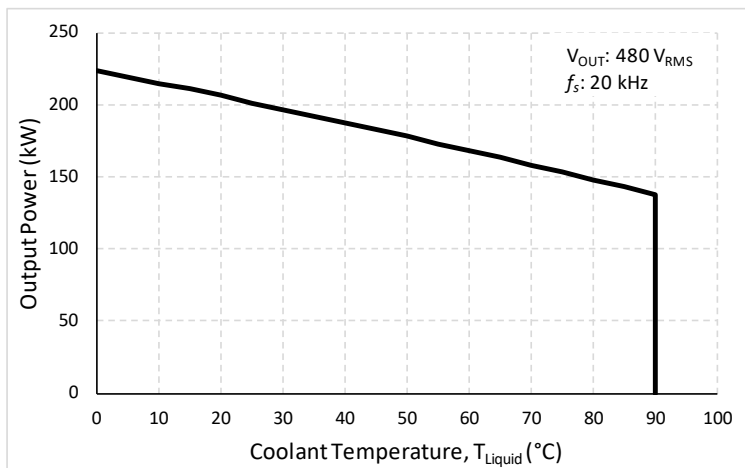
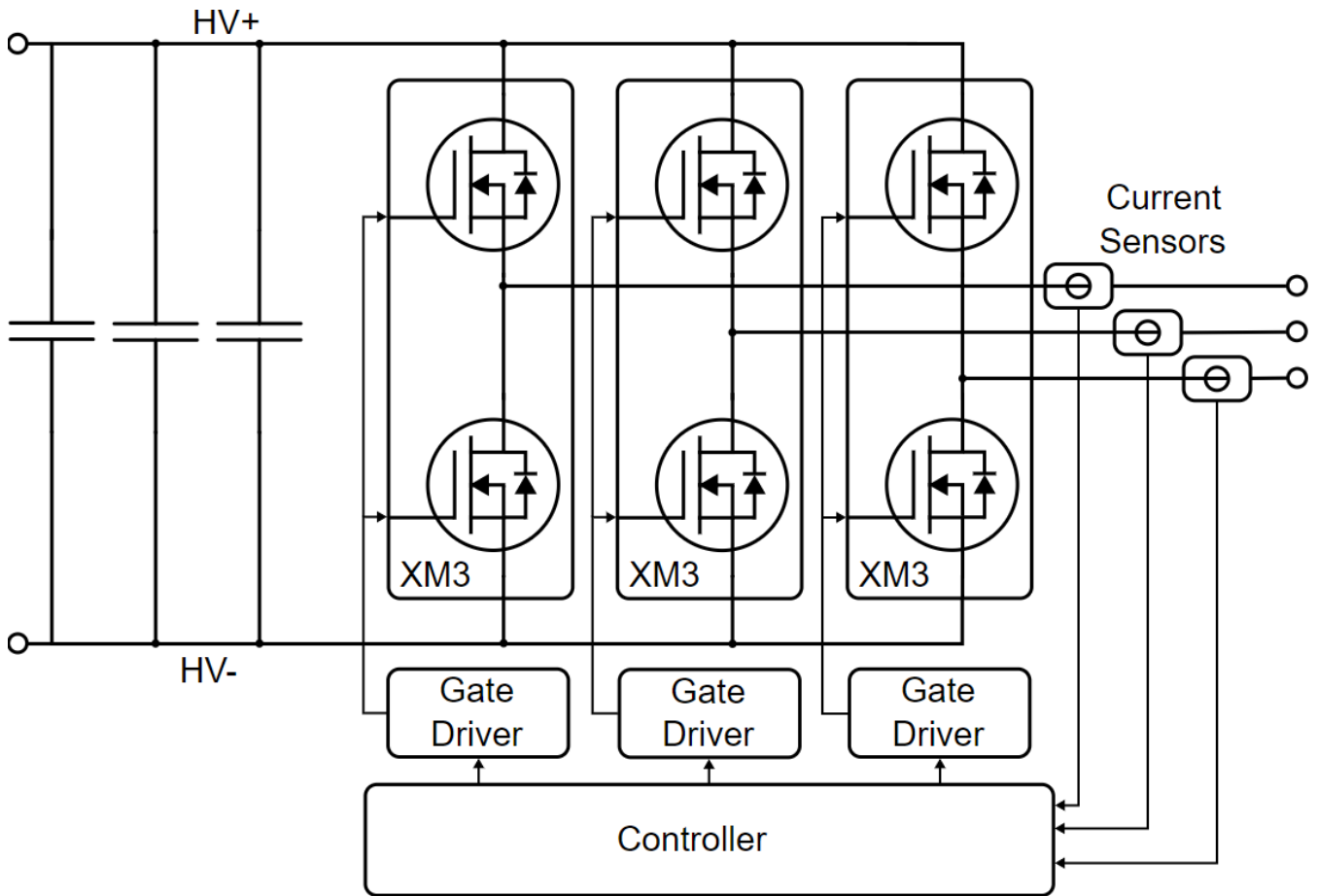

Figure 1. Output Power vs. Coolant Temperature





Full circuit schematics provided upon delivery of the reference design.



Package Dimensions (mm)

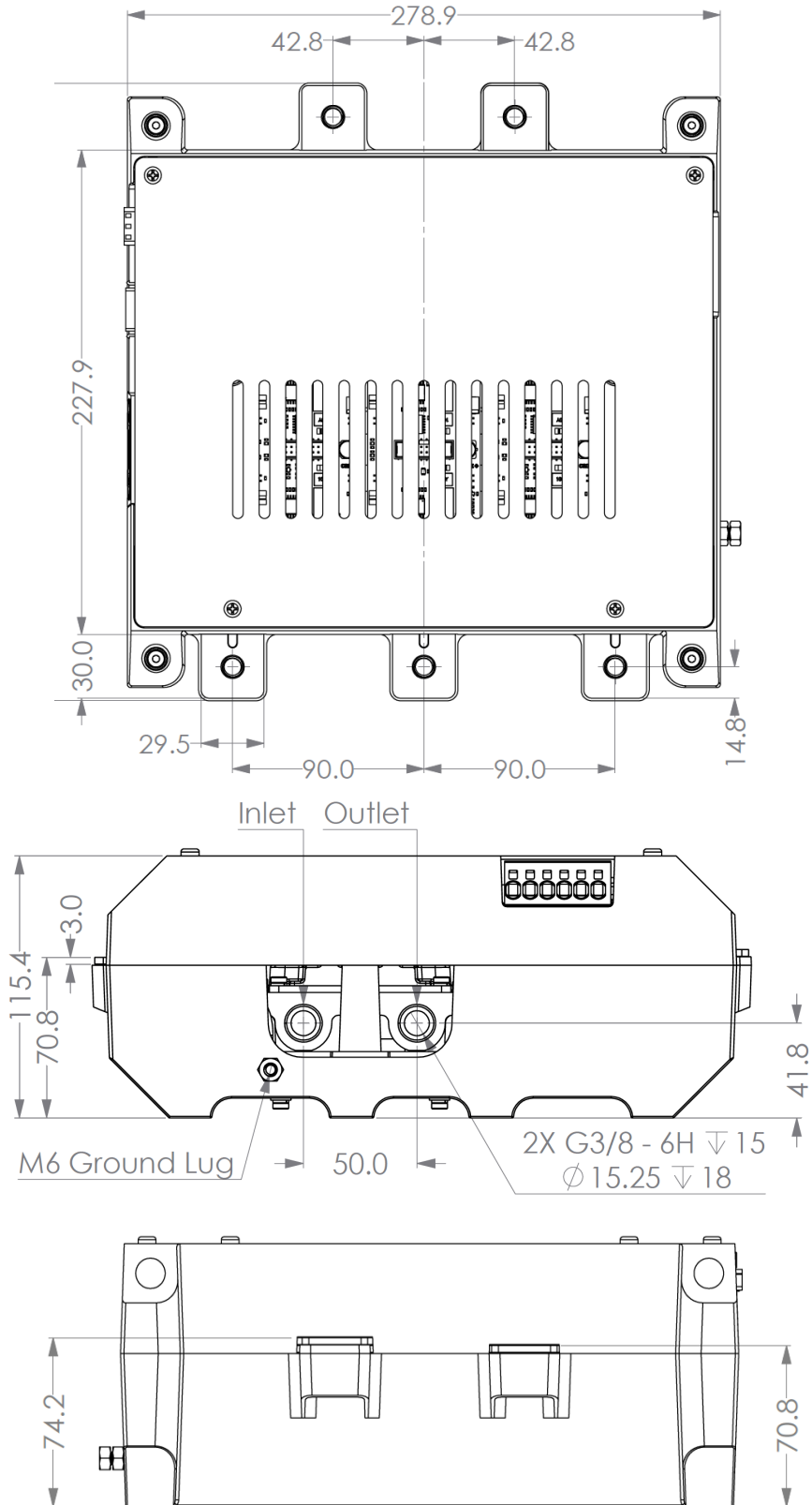

Supporting Links & Tools

- [CAB400M12XM3: 1200 V, 400A SiC Half-Bridge Module](#)
- [CGD12HBXMP: XM3 Evaluation Gate Driver](#)
- [CGD12HB00D: Differential Transceiver Board for CGD12HBXMP](#)
- [CRD300DA12E-XM3: 300 kW Inverter Kit for Conduction-Optimized XM3 \(CPWR-AN30\)](#)
- [KIT-CRD-CIL12N-XM3: Dynamic Performance Evaluation Board for the XM3 Module \(CPWR-AN31\)](#)
- [CPWR-AN28: Module Mounting Application Note](#)
- [CPWR-AN29: Thermal Interface Material Application Note](#)

Important Notes

- This Cree-designed reference design hardware for Cree components is meant to be used as an evaluation tool in a lab setting and to be handled and operated by highly qualified technicians or engineers. The hardware is not designed to meet any particular safety standards and the tool is not a production qualified assembly.
- Each part that is used in this reference design and is manufactured by an entity other than Cree or one of Cree's affiliates is provided "as is" without warranty of any kind, including but not limited to any warranty of non-infringement, merchantability, or fitness for a particular purpose, whether express or implied. There is no representation that the operation of each such part will be uninterrupted or error free.
- This product has not been designed or tested for use in, and is not intended for use in, applications implanted into the human body nor in applications in which failure of the product could lead to death, personal injury or property damage, including but not limited to equipment used in the operation of nuclear facilities, life-support machines, cardiac defibrillators or similar emergency medical equipment, aircraft navigation or communication or control systems, or air traffic control systems.
- The SiC MOSFET module switches at speeds beyond what is customarily associated with IGBT-based modules. Therefore, special precautions are required to realize optimal performance. The interconnection between the gate driver and module housing needs to be as short as possible. This will afford optimal switching time and avoid the potential for device oscillation. Also, great care is required to insure minimum inductance between the module and DC link capacitors to avoid excessive VDS overshoot.