

CR2032R-HE1

The High Drain lithium coin batteries feature excellent high-current discharge performance to support LPWA devices, as well as outdoor infrastructures and environment monitoring sensors.

In Production REACH

Appearance & Shape

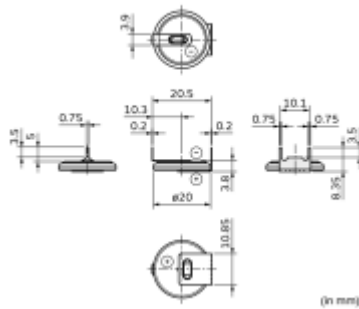
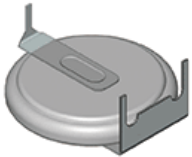

Applications

Other Usage • IoT · Tracking devices · Sensors · Security

Features

• Lightweight, High Voltage and High Energy Density

The battery voltage is 3V, almost double that of normal alkaline or manganese batteries. This means that the number of batteries required for equipment can be halved for maximum space saving and weight reduction.

• Excellent Discharge Characteristics

Voltage characteristics remain stable even for a long period of discharge, greatly improving the reliability of equipment that uses the battery. Such equipment is also maintenance-free (battery replacement is seldom required).

• Maximum pulse discharge current*1 - About double compared to conventional type

Compared to the Standard, the High Drain maintains high current even when the discharge continues. The maximum pulse discharge current*1 has been doubled to 50mA compared to that of Standard. This model can now be used for LPWA communication devices, such as LoRa with high peak currents, etc. which was difficult to be handled with the coin lithium battery in the past*2.

*1 Maximum current of pulsed discharge (3 seconds) at 2V or higher discharged with 50% nominal capacity at an ambient temperature of 23°C

*2 Peak current may vary according to the using environment and conditions of use

• Capacity usage rate, about 3 times compared to conventional type*3

Compared with the Standard, since the High Drain can maintain a high voltage even when the discharge continues, the capacity of the battery can be used effectively.

*3 Pulsed discharge at 45mA for 3 seconds and no discharge for 33 seconds at an ambient temperature of 23°C

• Excellent Leakage Resistance

The newly developed battery construction and electrolyte ensure maximum leakage resistance over a long span of

1 of 3

Attention

1. This datasheet is downloaded from the website of Murata Manufacturing Co., Ltd. Therefore, its specifications are subject to change or our products in it may be discontinued without advance notice. Please check with our sales representatives or product engineers before ordering.

2. This datasheet has only typical specifications because there is no space for detailed specifications.

Therefore, please review our product specifications or consult the approval sheet for product specifications before ordering.

CR2032R-HE1

Specifications

Battery type	Coin Manganese Dioxide Lithium Batteries
Nominal Voltage	3.0V
Nominal Capacity	200mAh
Recommended Continuous Discharge Current	3mA or less
Maximum Pulse Discharge Current(mA) *Assumption: Current to keep higher than 2V at 50% discharge with 23°C and pulse length 3sec.	50mA
Operating Temperature Range	-30°C to 70°C
Diameter (inch)	0.787inch
Diameter (mm)	20mm
Height (inch)	0.126inch
Height (mm)	3.2mm
IEC (JIS)	CR2032
Mass (oz)	0.12oz
Mass (g)	3.3g

Attention

1.This datasheet is downloaded from the website of Murata Manufacturing Co., Ltd. Therefore, it's specifications are subject to change or our products in it may be discontinued without advance notice. Please check with our sales representatives or product engineers before ordering.

2.This datasheet has only typical specifications because there is no space for detailed specifications.

Therefore, please review our product specifications or consult the approval sheet for product specifications before ordering.

CR2032R-HE1

Product Data

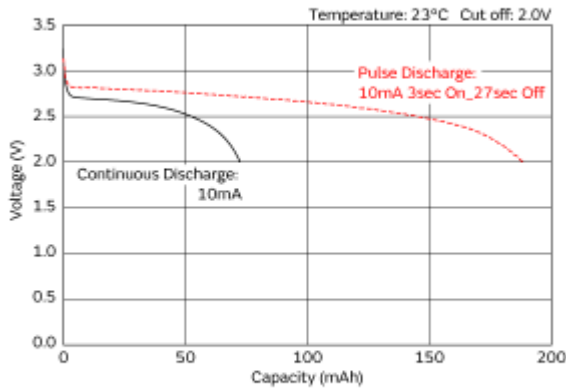

Discharge Characteristics

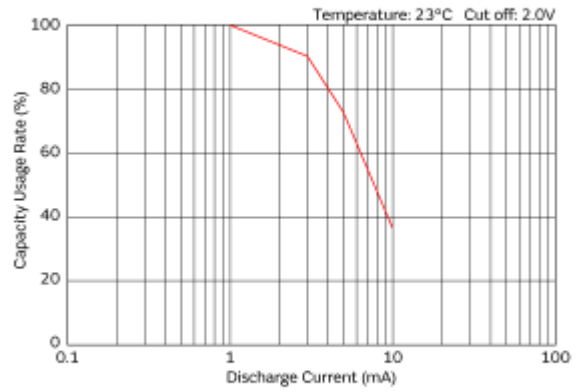

Discharge Characteristics on Load

Attention

1.This datasheet is downloaded from the website of Murata Manufacturing Co., Ltd. Therefore, it's specifications are subject to change or our products in it may be discontinued without advance notice. Please check with our sales representatives or product engineers before ordering.
2.This datasheet has only typical specifications because there is no space for detailed specifications.
Therefore, please review our product specifications or consult the approval sheet for product specifications before ordering.