

Programmable Controller CQM1H

The CQM1H's rack-less modular design lets you customize your control system by adding "inner boards" for advanced functions, as well as specialized I/O and communications modules. CQM1H offers the most flexibility of all PLC systems in its class.

- 4 different base CPUs to choose from; 16 DC inputs built in; expands up to 512 points
- No separate backplane required
- Inner Boards allow "customized" configuration of the CPU
- Serial communications inner board supports protocol macro feature for communication with third-party serial devices
- Supports all existing and new CQM1 I/O and specialized I/O modules
- Optional memory cassettes allow backup of sensitive data, provides a real-time clock
- ControllerLink network transmits 8 kword data packets at up to 2 Mbps; 32 nodes
- Advanced instruction set includes PID, floating point math, protocol macro instructions and more
- CompoBus/S, SYSMAC BUS and AS-interface masters support remote I/O
- Up to 15.2 kwords of program memory

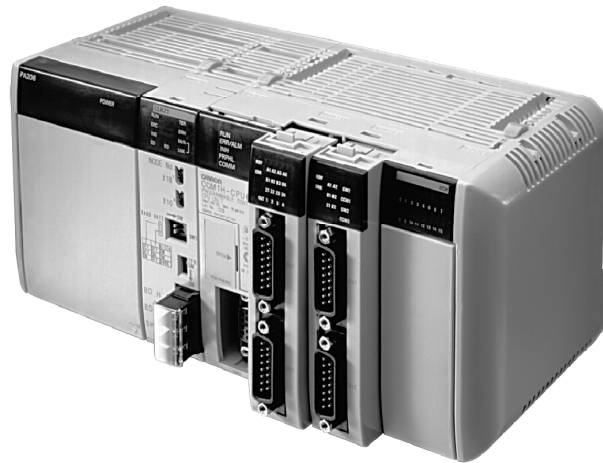

Basic Configuration

Select the CPU and I/O modules (discrete, analog and dedicated special function types) then determine the power supply based on the current consumption. The I/O Control and Interface adapters give you the option of dividing the CPU and I/O system into two narrower units than the examples shown below. The CQM1H-CPU51/CPU61 models offer space-saving position and motion control solutions as well as additional analog and serial communications capabilities right at the CPU.

CQM1H modules are assembled with connectors on their sides.

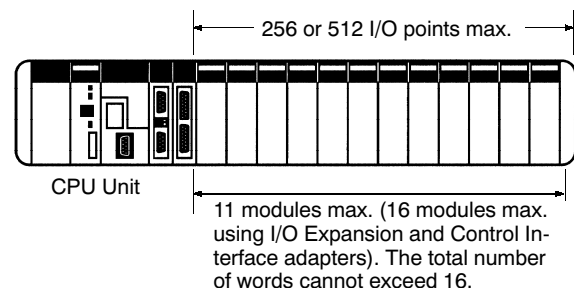
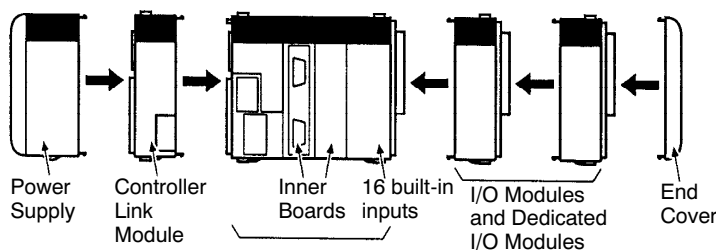

Ordering Information

■ CPU

Stock Note: Shaded models are normally stocked.

Specifications						International standards	Part number
Memory capacity	Max. I/O capacity	Built-in inputs	Built-in RS-232C port	Support of Inner Boards	Support of Controller Link Unit		
Program: 3.2 kwords DM area: 3 kwords	256 points	16 DC inputs	No	No	No	U, C, N, CE	CQM1H-CPU11
			Yes				
Program: 7.2 kwords DM area: 6 kwords	512 points			Yes	Yes		CQM1H-CPU51
Program: 15.2 kwords DM area: 6 kwords EM area: 6 kwords							

■ POWER SUPPLY MODULES

Stock Note: Shaded models are normally stocked.

Item	Specifications				International standards	Part number
	Rated voltage	Allowed voltage range	Output capacity	Service power supply		
AC power supply modules	100 to 240 VAC, 50/60 Hz	85 to 265 VAC	18 W	None	U, C, N, L, CE	CQM1-PA203
			30 W	24 VDC, 0.5 A	U, C, L, N	CQM1-PA206
	110/230 VAC, 50/60 Hz	80 to 138 VAC 160 to 276 VAC	30 W	24 VDC, 0.5 A	CE	CQM1-PA216
DC power supply modules	24 VDC	20 to 28 VDC	30 W	—	U, C, N, L, CE	CQM1-PD026

■ MEMORY CASSETTES

Stock Note: Shaded models are normally stocked.

Memory	Memory capacity/Clock function	International standards	Part number
Flash memory	16 kwords	U, C, N, CE	CQM1H-ME16K
	with clock		CQM1H-ME16R
EEPROM	8 kwords	U, C, N, L, CE	CQM1-ME08K
			with clock
	4 kwords		CQM1-ME04K
			with clock
EPROM memory cassette (Memory chip not included)	Cassette with IC socket only (EPROM chip sold separately)		CQM1-MP08K
	with clock		CQM1-MP08R
EPROM chip	128 KB (8 kwords), 150 ns, 27128 IC or equivalent, 12.5 V	L	ROM-ID-B
	256 KB (16 kwords), 150 ns, 27256 IC or equivalent, 12.5 V	CE	ROM-JD-B
	512 KB (32 kwords), 150 ns, 27512 IC or equivalent, 12.5 V		ROM-KD-B

■ I/O EXPANSION AND CONTROL INTERFACE ADAPTERS

Stock Note: Shaded models are normally stocked.

Use I/O Expansion and Control Interface adapters for applications that require 11 to 16 I/O modules.

Memory	Memory capacity/Clock function	International standards	Part number
I/O control adapter	Connects to right-hand side of CPU block	U, C, CE	CQM1H-IC101
I/O interface adapter	Connects to left-hand side of Expansion I/O block		CQM1H-II101
I/O extension cable	Connects the I/O control module to the I/O interface module	L, CE	Cable length: 0.3 m CS1W-CN313
			Cable length: 0.7 m CS1W-CN713

Note: U: UL, C: CSA, N: NK, L: LLOYD, CE: EC Directives

■ I/O MODULES

Stock Note: Shaded models are normally stocked.

Input Modules

Input type	Number of inputs	Input voltage	Input current	Common type	Connector type	International standards	Part number
DC inputs	8	12 to 24 VDC	10 mA	Independent	Terminal block	U, C, N, L, CE	CQM1-ID211
	16	12 VDC	6 mA	Shared		U, C	CQM1-ID111
		24 VDC				U, C, N, L, CE	CQM1-ID212
	32	12 VDC	4 mA	Shared	Connector	U, C	CQM1-ID112
		24 VDC				U, C, N, L, CE	CQM1-ID213
	AC inputs	8	100 to 120 VAC	5 mA	Shared	Terminal block	U, C, L, CE
200 to 240 VAC			6 mA	CQM1-IA221			

Output Modules

Output type	Number of outputs	Max. switching voltage	Max. switching current	Common type	Connector type	International standards	Part number
Contact outputs	8	250 VAC, 24 VDC	2 A	Independent	Terminal block	U, C, N, L	CQM1-OC221
	16			Shared			CQM1-OC222
	8			Independent			CE, U
Transistor	8	24 VDC	2 A (NPN)	Shared (fused)	Terminal block	U, C, N, L, CE	CQM1-OD211
	16						0.3 A (NPN)
	32				0.1 A (NPN)		Connector
Transistor	8	24 VDC	1 A (PNP)	Shared (fused)	Terminal block	U, C, L, CE	CQM1-OD215
	16						0.3 A (PNP)
	32				0.5 A (PNP)		Connector
Triac	8	240 VAC	0.4 A	Shared (short circuit protected)	Terminal block	U, C, L	CQM1-OA221
	6					CE	CQM1-OA222

■ INNER BOARDS

Stock Note: Shaded models are normally stocked.

Item	Specifications	International standards	Part number
High-speed counter board	4 pulse inputs (high-speed counter) at 500 kHz max. 4 external outputs	U, C, N, CE	CQM1H-CTB41
Pulse I/O board	2 pulse inputs: Single-phase: 50 kHz, Differential phase: 25 kHz 2 pulse outputs: 50 kHz max., both fixed and variable duty factors are supported.	U, C	CQM1H-PLB21
Absolute encoder interface board	2 absolute encoder (gray code binary) inputs (4 kHz)	U, C, N	CQM1H-ABB21
Analog setting board	4 analog settings	U, C, N, CE	CQM1H-AVB41
Analog I/O board	4 analog inputs of 0 to 5 V, 0 to 20 mA, -10 to +10 V 2 analog outputs of 0 to 20 mA, -10 to +10 V	CE	CQM1H-MAB42
Serial communications board	One RS-232C port and one RS-422A/RS-485 port	U, C, N, CE	CQM1H-SCB41

Note: U: UL, C: CSA, N: NK, L: LLOYD, CE: EC Directives

■ COMMUNICATION MODULES

Stock Note: Shaded models are normally stocked.

Controller Network Module

Item	Specifications	International standards	Part number
Controller Link module (wired)	Data link (Maximum number of words per node: 8,000) Communications instructions: SEND/RECV/CMND	U, C, CE	CQM1H-CLK21

Field Network Modules

Item	Specifications	International standards	Part number
CompoBus/S master module	Number of I/O points per Master: 128 (64 inputs and 64 outputs;) Communications cycle time: 0.5 ms min. Max. transmission distance: 500 m in long-distance mode 100 m in high-speed mode Max. slaves per master: 32	U, C, CE	CQM1-SRM21-V1
SYSMAC BUS modules	Remote master (*Use G730 transistor and relay output modules.) Connects CQM1H to G730 SYSMAC BUS remote I/O modules; max. 64 I/O (32 or 16 inputs or outputs, DIP switch selectable) Number of I/O points per Master: 128 Communications cycle time: 187.5 kbps Max. transmission distance: 200 m One master and two expansions allowed per system		CQM1-G7M21
	Input expansion Expands G730 input capacity of G730 remote master; adds 32 or 16 inputs, DIP switch selected		CQM1-G7N11
	Output expansion Expands G730 output capacity of G730 remote master; adds 32 or 16 outputs, DIP switch selected		CQM1-G7N01
DeviceNet I/O link module	Number of I/O points: 16 inputs and 16 outputs Maps the 16 inputs and 16 outputs as a single node.		CQM1-DRT21
Profibus-DP I/O link unit	Number of I/O points: 128 inputs and 128 outputs	U, C, CE	CQM1-PRT21
AS-interface master module	Number of I/O points: 248 (124 inputs and 124 outputs; 4 inputs/4 outputs per slave) Communications cycle time: 5.148 ms min. Max. transmission distance: 100 m; 300 m with 2 repeaters Max. slaves per master: 31 slaves per master module	U, C, CE	CQM1-ARM21

Note: *G730 transistor and relay output modules are shown in the Complementary Products section in this catalog.

■ DEDICATED I/O MODULES

Stock Note: Shaded models are normally stocked.

Item	Specifications	International standards	Part number	
Analog I/O modules	Analog inputs: 4 points, built-in power supply	U, C, N, CE	CQM1-AD042	
	Analog inputs: 4 points, order separate power supply	U, C, N, CE	CQM1-AD041	
	Analog outputs: 2 points, built-in power supply	U, C, N, CE	CQM1-DA022	
	Analog outputs: 2 points, order separate power supply		CQM1-DA021	
	Power Supply Module re-quired for AD041 and DA021 modules		For one Analog module	CQM1-IPS01
			For two Analog modules	CQM1-IPS02
B7A Master link modules*	16 outputs	—	CQM1-B7A02	
	16 inputs	U, C	CQM1-B7A12	
	32 outputs		CQM1-B7A03	
	32 inputs		CQM1-B7A13	
	16 inputs and 16 outputs	—	CQM1-B7A21	
Temperature controller modules	Thermocouple input, transistor (NPN) output, 2 loops	U, C, CE	CQM1-TC001	
	Thermocouple input, transistor (PNP) output, 2 loops		CQM1-TC002	
	Platinum resistance thermometer input, transistor (NPN) output, 2 loops		CQM1-TC101	
	Platinum resistance thermometer input, transistor (PNP) output, 2 loops		CQM1-TC102	
Temperature controller modules (continued)	Thermocouple input, transistor (NPN) output, 4 loops	U, C, CE	CQM1-TC201	
	Thermocouple input, transistor (PNP) output, 4 loops		CQM1-TC202	
	Thermocouple input, transistor (NPN) output, 2 loops (with heater burnout alarm)		CQM1-TC203	
	Thermocouple input, transistor (PNP) output, 2 loops (with heater burnout alarm)		CQM1-TC204	
	Platinum resistance thermometer input, transistor (NPN) output, 4 loops		CQM1-TC301	
	Platinum resistance thermometer input, transistor (PNP) output, 4 loops		CQM1-TC302	
	Platinum resistance thermometer input, transistor (NPN) output, 2 loops (with heater burnout alarm)		CQM1-TC303	
	Platinum resistance thermometer input, transistor (PNP) output, 2 loops (with heater burnout alarm)		CQM1-TC304	
Linear sensor interface modules	Standard	—	CQM1-LSE01	
	With monitor output		CQM1-LSE02	
Safety relay module	Emergency stop unit: 2 inputs/2 outputs, 4 general-purpose inputs	U, C	CQM1-SF200	

Note: U: UL, C: CSA, N: NK, L: LLOYD, CE: EC Directives

*B7A Slave Link Modules are listed in the Dedicated I/O Modules section describing B7A Master Link Modules.

■ PROGRAMMING DEVICES AND ACCESSORIES

Stock Note: Shaded models are normally stocked.

Programming Consoles

Item	Specifications	International standards	Part number
Programming consoles	2-m Connecting Cable included (No other Connecting Cables required.)	U, C, CE	CQM1H-PRO01-E
	Requires a separate Connecting Cable, see below.	U, C, N, CE	C200H-PRO27-E
Connecting cables	Cable length: 2 m	N	C200H-CN222
	Cable length: 2 m (for CPUs complying with EC directives)	CE	C200HS-CN222
	Cable length: 2 m	CE	CS1W-CN224
	Cable length: 6 m	CE	CS1W-CN624
Peripheral port conversion cable	Connects the peripheral port on the CQM1H to a personal computer or Programming Console through a CQM1-CIF02 cable.	CE	CS1W-CN114

Communications Adapters and Cables

Description	Function	Cable length	Part number
Cables and adapters	DB 9-pin on computer to CQM1H mini-peripheral port	2 m	CS1W-CN226
		6 m	CS1W-CN626
	Serial port on computer to Omron DB 9-pin serial port	2 m	C200HS-CN220-EU
			CBL-202*
	25-9 pin cable, operator interface to Omron PLC	50 cm	NT31C-CN510-EU
			NT31C-CN320-EU
			CBL-803*
	25-9 pin cable, operator interface to Omron PLC	5 m	NT31C-CN520-EU
	Operator interface to Omron peripheral port cable	2 m	XW2Z-200T-2
			XW2Z-500T-2
	9-9 pin cable, operator interface to Omron PLC	50 cm	C200H-CN510-EU
			C200H-CN320-EU
			CBL-804*
	Serial port on computer to Omron DB 9-pin serial port	2 m	C200H-CN229-EU
			CBL-202*
Converts the CQM1H CPU mini-peripheral port to an RS-232C port	0.1 m	CS1W-CN118	
Converts CQM1-CIF02 peripheral connector to CQM1H's mini-peripheral port	0.05 m	CS1W-CN114	
Cable mounted communication adapter converts peripheral port to DB 9-pin serial port	3.3 m	CQM1-CIF02	
Mini-peripheral port to RS-422 adapter, DIN mount	—	CQM1H-CIF12	

* Available in Canada only.

Software

Item	Specifications	Cable length	International standards	Part number
CX-Programmer	Write and debug programs; monitor operation CD-ROM	—	—	WS02-CXPC1-E-V □.□

Program Transfer Tools

Item	International standards	Part number
Expansion memory unit uploads and downloads program and setup memory areas to and from the controller.	—	CPM1-EMU01-V1
EEPROM (256 kbits)	—	EEPROM-CPM1-EMU01

■ MAINTENANCE PRODUCTS

Stock Note: Shaded models are normally stocked.

Item	Function	International standards	Part number
Battery	Backs up memory in the CPU.	—	CPM2A-BAT01
End cover	Connects to the I/O module located on the extreme right	U, C, CE	CQM1H-TER01

■ DIN TRACK

Stock Note: Shaded models are normally stocked.

Item	Specifications		International standards	Part number
Mounting track	Track length: 50 cm	Height: 7.3 mm	L	PFP-50N
	Track length: 1 m			PFP-100N
	Track length: 1 m	Height: 16 mm		PFP-100N2
End plate	Fasten mounting brackets on both sides of the PLC to prevent it from sliding left or right.			PFP-M

Note: U: UL, C: CSA, N: NK, L: LLOYD, CE: EC Directives

■ MANUALS

Product	Description	Part number
Operation manual	CQM1H CPUs and Inner Boards operation manual	W363
Programming manual	CQM1H CPUs and Inner Boards programming manual	W364
Dedicated I/O Modules manual	Covers analog input/output, B7A Link master, temperature controller, linear sensor interface, and safety relay modules.	W238

CPUs

The four models of CPUs can be broadly divided into two groups: Models that support Inner Boards and the Controller Link Unit, and models that do not. The CPUs also vary in their program capacities, I/O capacities, memory capacities, and the presence of an RS-232C port, as shown in the *Basic Specifications* table, below.

■ NOMENCLATURE

The following illustration shows the main components of a CQM1H-CPU61 CPU.

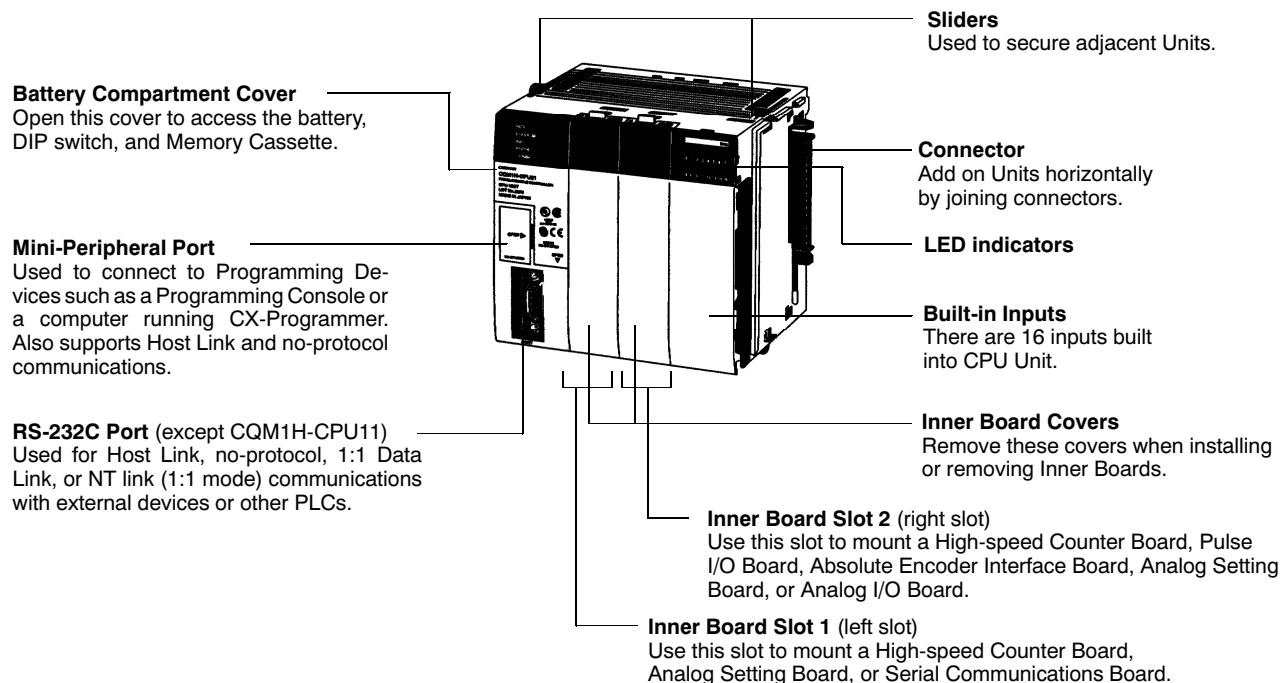

■ OVERVIEW

Model	I/O capacity (See Note.)	Program capacity (words)	DM capacity (words)	EM capacity (words)	CPU Unit built-in inputs	Built-in serial ports		Inner Boards	Controller Link Module
						Peripheral port	RS-232C port		
CQM1H-CPU61	512	15.2 K	6 K	6 K	DC: 16	Yes	Yes	Supported	
CQM1H-CPU51		7.2 K	6 K	None					
CQM1H-CPU21	256	3.2 K	3 K					Not supported	
CQM1H-CPU11									

■ MAXIMUM NUMBER OF MODULES

CPU	Controller Link Module	Inner Boards	I/O Modules and Dedicated I/O Modules
CQM1H-CPU61	1 max.	2 max.	11 max.
CQM1H-CPU51			16 max. using I/O Expansion and Control Interface modules
CQM1H-CPU21	Not supported.	Not supported.	
CQM1H-CPU11			

Note: I/O capacity = Number of input points (≤ 256) + Number of output points (≤ 256).

■ CPU UNIT SPECIFICATIONS

Characteristics

Item	Specifications	
Control method	Stored program method	
I/O control method	Cyclic scan and direct output/immediate interrupt processing	
Programming language	Ladder-diagram programming	
I/O capacity	CQM1H-CPU11/21: 256 CQM1H-CPU51/61: 512	
Program capacity	CQM1H-CPU11/21 : 3.2 kwords CQM1H-CPU51 : 7.2 kwords CQM1H-CPU61 : 15.2 kwords	
User data memory capacity	CQM1H-CPU11/21 : 3 kwords CQM1H-CPU51 : 6 kwords CQM1H-CPU61 : 12 kwords (DM: 6 kwords; EM: 6 kwords)	
Instruction length	1 step per instruction, 1 to 4 words per instruction	
Number of instructions	162 (14 basic, 148 special instructions)	
Instruction execution times	Basic instructions: 0.375 to 1.125 μ s Special instructions: 17.7 μ s (MOV instruction)	
Overseeing time	0.70 ms	
Mounting structure	No backplane (Modules are joined horizontally using connectors)	
Mounting	DIN Track mounting (screw mounting not possible)	
CPU built-in DC input points	16	
Maximum number of modules	Maximum of 11 modules total for I/O modules and Dedicated I/O modules	
Inner Boards	CQM1H-CPU11/21: None CQM1H-CPU51/61: 2 Boards	
Communications modules (Controller Link Module)	CQM1H-CPU11/21: None CQM1H-CPU51/61: 1 module	
Types of interrupts	Input interrupts (4 inputs max.)	Input Interrupt Mode: Interrupts are executed in response to inputs from external sources to the CPU's built-in input points. Counter Mode: Interrupts are executed in response to reception of a set number of pulses (counted down) via the CPU's internal built-in input points (4 points).
	Interval timer interrupts (3 timers max.)	Scheduled Interrupt Mode: Program is interrupted at regular intervals measured by one of the CPU's internal timers. One-shot Interrupt Mode: An interrupt is executed after a set time, measured by one of the CPU's internal timers.
	High-speed counter interrupts	Target Value Comparison: Interrupt is executed when the high-speed counter PV is equal to a specified value. Range Comparison: Interrupt is executed when the high-speed counter PV lies within a specified range. Counting is possible for high-speed counter inputs from the CPU's internal input points, Pulse I/O Boards, or Absolute Encoder Interface Boards. (The High-speed Counter Board has no interrupt function, but can output bit patterns internally and externally.)
I/O allocations	I/O is automatically allocated in order from the Unit nearest to the CPU. (Because there are no I/O tables, it is not necessary to create I/O tables from a Programming Device.)	

Memory Area Structure

Data area		Size	Words	Bits	Function
IR area	Input area	256 bits	IR 000 to IR 015	IR 00000 to IR 01515	Input bits are allocated to Input Units or Dedicated I/O Units. The 16 bits in IR 000 are always allocated to the CPU's built-in inputs. Bits in IR 001 to IR 015 are allocated to I/O or Dedicated I/O Units connected to the CPU.
IR area	Output area	256 bits	IR 100 to IR 115	IR 10000 to IR 11515	Output bits are allocated to Output Units or Dedicated I/O Units connected to the CPU.
	Work areas	2,528 bits min.	IR 016 to IR 089	IR 01600 to IR 08915	Work bits do not have any specific function and they can be freely used within the program. (A minimum 2,528 bits are available as work bits. Most bits in the IR and LR areas can be used as work bits when they are not used for their allocated functions, so the total number of available work bits depends on the configuration of the PLC.)
			IR 116 to IR 189	IR 11600 to IR 18915	
			IR 216 to IR 219	IR 21600 to IR 21915	
			IR 224 to IR 229	IR 22400 to IR 22915	
Controller Link status areas		96 bits	IR 090 to IR 095	IR 09000 to IR 09515	Status Area 1: Stores the Controller Link data link status information.
			IR 190 to IR 195	IR 19000 to IR 19515	Status Area 2: Stores the Controller Link error and network participation information.
MACRO operand area	Input area	64 bits	IR 096 to IR 099	IR 09600 to IR 09915	Used when the MACRO instruction, MCRO(99), is used.
	Output area	64 bits	IR 196 to IR 199	IR 19600 to IR 19915	
Inner Board slot 1 area		256 bits	IR 200 to IR 215	IR 20000 to IR 21515	These bits are allocated to the Inner Board mounted in slot 1 of a CQM1H-CPU51/61. High-speed Counter Board: IR 200 to IR 213 Serial Communications Board: IR 200 to IR 207
Analog settings area		64 bits	IR 220 to IR 223	IR 22000 to IR 22315	Used to store the analog settings when a CQM1H-AVB41 Analog Setting Board is mounted.
High-speed Counter, 0 PV		32 bits	IR 230 to IR 231	IR 23000 to IR 23115	Used to store the present values of high-speed counter 0.
Inner Board slot 2 area		192 bits	IR 232 to IR 243	IR 23200 to IR 24315	These bits are allocated to the Inner Board mounted in slot 2. High-speed Counter Board: IR 232 to IR 243 Absolute Encoder Interface Board: IR 232 to IR 239 Pulse I/O Board: IR 232 to IR 239 Analog I/O Board: IR 232 to IR 239
SR area		184 bits	SR 244 to SR 255	SR 24400 to SR 25507	These bits serve specific functions such as flags and control bits.
HR area		1,600 bits	HR 00 to HR 99	HR 0000 to HR 9915	These bits store data and retain their ON/OFF status when power is turned OFF or when the operating mode is changed.
AR area		448 bits	AR 00 to AR 27	AR 0000 to AR 2715	These bits serve specific functions such as flags and control bits.
TR area		8 bits	—	TR 0 to TR 7	These bits are used to temporarily store ON/OFF status at program branches.
LR area		1,024 bits	LR 00 to LR 63	LR 0000 to LR 6315	Used for 1:1 data link through the RS-232 port or through a Controller Link module.
Timer/Counter area		512 bits	TIM/CNT 000 to TIM/CNT 511 (timer/counter numbers)		The same numbers are used for both timers and counters. Timer numbers 000 to 015 can be used with TIMH(15) for interrupt-refreshed PVs to ensure proper timing without inaccuracy being caused by the cycle time.

(This table continues on the next page.)

Memory Area Structure - continued from previous page

Data area		Size	Words	Bits	Function
DM area	Read/write	3,072 words	DM 0000 to DM 3071	—	DM area data can be accessed in word units only. Word values are retained when the power is turned OFF.
		3,072 words	DM 3072 to DM 6143	—	Available in CQM1H-CPU51/61 CPUs only.
	Read-only	425 words	DM 6144 to DM 6568	—	Cannot be written from the program (only from a Programming Device). DM 6400 to DM 6409: Controller Link parameters DM 6450 to DM 6499: Routing tables DM 6550 to DM 6559: Serial Communications Board Setup
	Error history area	31 words	DM 6569 to DM 6599	—	Cannot be written from the program (only from a Programming Device). Stores the time of occurrence and error code of errors that occur.
	PLC setup	56 words	DM 6600 to DM 6655	—	Cannot be written from the program (only from a Programming Device). Stores various parameters that control PLC operation.
EM area		6,144 words	EM 0000 to EM 6143	—	EM area data can be accessed in word units only. Word values are retained when the power is turned OFF or the operating mode is changed. (CQM1H-CPU61 CPU Unit only.)

Other Functions

Item	Specification
Macro instructions	Subroutines called by instructions containing arguments.
Min. cycle time	1 to 9,999 ms (Unit: 1 ms)
Cycle time monitoring	When the cycle time exceeds 100 ms, the Cycle Time Over Flag turns ON, and operation continues. (A setting can be made in the PLC Setup so that this error is not generated.) When the cycle time exceeds the cycle monitor time, operation is stopped. Cycle monitor time settings: 0 to 990 ms in 10-ms units, 0 to 9,900 ms in 100-ms units, 0 to 99 s in 1-s units. The maximum and current values of the cycle time are stored in the AR area.
I/O refreshing	Cyclic refreshing, refreshing by IORF(97), direct output refreshing (set in the PLC Setup), interrupt input refreshing. (The inputs that are refreshed can be set separately for input interrupts, high-speed counter interrupts, and interval timer interrupts in the PLC Setup.)
I/O memory status when changing operating mode	Depends on the ON/OFF status of the I/O Hold Bit (SR 25212).
Load OFF	All outputs on Output Units can be turned OFF when the CPU is operating in RUN, MONITOR, or PROGRAM mode. (Used for stopping output in emergencies, for debugging, etc.)
User-customized DIP switch setting	A pin setting on the DIP switch on the front of the CPU is stored in AR 0712. This setting can be used as an ON/OFF condition (e.g., to switch between trial operation and actual operation).
Mode setting at power-up	Possible
Debugging	Forced set/reset, differential monitoring, data tracing (scheduled, cyclic, or when instruction is executed).
Online editing	User programs can be overwritten in program-block units when the CPU is in MONITOR mode. With the CX-Programmer, more than one program block can be edited at the same time.
Program protection	Write-protection of user program and data memory (DM 6144 to DM 6655: read-only DM): Set using pin 1 of the DIP switch.
Error check	User-defined errors (i.e., user can define fatal errors and non-fatal errors using the FAL(06) and FALS(07) instructions.) (It is possible to stop operation using FALS(07) for fatal errors.) User-defined error logs can be created in specific bits (logging) when using FAL(06).
Error log	Up to 10 errors (including user-defined errors) are stored in the error log. Information includes the error code, error details, and the time the error occurred.
Serial communications	Built-in mini-peripheral port: Programming Device (including Programming Console) connections, Host Links, no-protocol communications Built-in RS-232C port: Programming Device (excluding Programming Console) connections, Host Links, no-protocol communications, NT Links (1:1 mode), 1:1 Data LInks RS-232C port and RS-422A/485 port on Serial Communications Board (sold separately): Programming Device (excluding Programming Console) connections, Host Links, no-protocol communications, NT Links (1:1 mode, 1:N mode), 1:1 Data LInks, protocol macros

(This table continues on the next page.)

Other Functions - continued from previous page

Item	Specification	Built-in mini-peripheral port	Built-in RS-232C port	Serial communications board
Serial communications modes				
Programming console bus	Connects to Programming Console.	YES (pin 7 OFF)	No	No
Peripheral bus	Connects to a computer running CX-Programmer or other Support Software. (Automatically used if the network type is set to peripheral bus on the Support Software.)	YES (pin 7 ON)	No	No
Host Link (SYSMAC WAY)	Enables reading/writing CPU I/O memory or program using Host Link commands. Computers running Support Software or OMRON Programmable Terminals can also be connected. PLC-initiated communications are possible.	YES (pin 7 ON)	YES	YES
No-protocol	Enables sending or receiving up to 256 bytes of data without a protocol or data conversion. A start code, end code, and transmission delay can be set.	YES (pin 7 ON)	YES	YES
1:1 data link	Enables 1:1 data link with a CQM1H, CQM1, CPM-series, C200HX/HG/HE, C200HS, or SRM1 PLC.	No	YES	YES
NT links (1:1 and 1:N)	Enables 1:1 or 1:N communications with OMRON Programmable Terminals without additional programming.	No	YES (1:1 only)	YES (1:1 and 1:N)
Protocol macros	Enables user-created protocols to communicate with essential any device equipped with a serial communications port (e.g., RS-232C). Standard protocols are also provided.	No	No	YES
Clock	Some Memory Cassette are equipped with a clock. (The time of the error will recorded if a clock is used.)			
Input time constants	Used to set the ON (or OFF) response times for DC Input modules. Settings: 1, 2, 4, 8, 16, 32, 64, and 128 ms.			
Power OFF detection time	AC power supply: 10 to 25 ms (not fixed), DC power supply: 5 to 25 ms (not fixed)			
Memory protection	Held Areas: Holding bits, contents of Data Memory and Extended Data Memory, and status of the counter Completion Flags and present values. If the I/O Hold Bit (SR 25212) is turned ON, and the PLC Setup is set to maintain the I/O Hold Bit status when power is turned ON, the contents of the IR area and the LR area will be saved.			
Commands to a host computer	Host Link command responses can be sent to a computer connected via the Host Link System using the TXD(—) (communications port output) instruction.			
Remote programming and monitoring	Host Link or peripheral bus communications via a CPU's serial communications port can be used for remote programming and remote monitoring of the PLC through a Controller Link System. (This function is, however, not supported for the serial communications ports on the Serial Communications Board.)			
Program check	Program is checked at the beginning of operation for items such as no END(01) instruction and instruction errors. CX-Programmer can also check programs. (The level of program checking can be set.)			
Battery life	5 years at 25°C (Depends on the ambient temperature and power supply conditions. Min.: 1 yr) Battery replacement must be performed within 5 minutes.			
Errors from self-diagnostics	CPU (watchdog timer), I/O verification, I/O bus, memory, FALS system (FALS execution or cycle monitor time over), FAL system (FAL execution or PLC Setup error etc.), battery, cycle time over and communications port.			
Other functions	Storage of number of times power has been interrupted. (Stored in AR area.)			

Power Supply Units

Both AC and DC Power Supply Units are available. The AC Power Supply Units require a power supply input from 100 to 240 VAC and two of the AC Power Supply Units are equipped with an auxiliary 24 VDC power supply output.

The CQM1H's left End Cover is part of the Power Supply Unit.

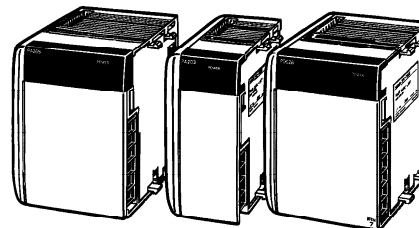

CQM1-PA206 CQM1-PA203 CQM1-PD026
CQM1-PA216

■ SPECIFICATIONS

Item	CQM1-PA203	CQM1-PA206	CQM1-PA216	CQM1-PD026
Supply voltage	100 to 240 VAC, 50/60 Hz		100 or 230 VAC (selectable), 50/60 Hz	24 VDC
Operating voltage range	85 to 264 VAC		85 to 132 VAC or 170 to 264 VAC	20 to 28 VDC
Operating frequency range	47 to 63 Hz			—
Power consumption	60 VA max.	120 VA max.		50 W max.
Inrush current	30 A max.			
Output capacity	5 VDC: 3.6 A (18 W)	5 VDC: 6 A 24 VDC: 0.5 A (30 W total)		5 VDC: 6 A (30 W)
Insulation resistance	20 MΩ min. at 500 VDC between AC external terminals and GR terminals			
Dielectric strength	2,300 VAC 50/60 Hz for 1 min between AC external and GR terminals, leakage current: 10 mA max. 1,000 VAC 50/60 Hz for 1 min between DC external and GR terminals, leakage current: 20 mA max.			
Noise immunity	Conforms to IEC61000-4-4, 2 kV (power lines)			
Vibration resistance	10 to 57 Hz with an amplitude of 0.075 mm, and 57 to 150 Hz with an acceleration of 9.8 m/s ² in the X, Y, and Z directions for 80 minutes each (i.e., swept for 8 minutes, 10 times).			
Shock resistance	147 m/s ² (118 m/s ² for Contact Output Units) 3 times each in X, Y, and Z directions			
Ambient temperature	Operating: 0° to 55°C (32° to 131°F) Storage: -20° to 75°C (-4° to 167°F), except battery			
Ambient operating humidity	10% to 90% RH (no condensation)			
Operating environment	No corrosive gas			
Ground	Less than 100 Ω			
Construction	Panel mounted			
Weight	5 kg max.			
Internal current consumption	CQM1H-CPU11: 820 mA at 5 VDC CQM1H-CPU21/51/61: 840 mA at 5 VDC			
Dimensions (without cables)	CQM1H-CPU11/21: 187 to 571 × 110 × 107 mm (W×H×D) CQM1H-CPU51/61: 187 to 603 × 110 × 107 mm (W×H×D)			
Accessories	RS-232C connector (one XM2A-0901 Plug and one XM2S-0911-E Hood) (except CQM1H-CPU11) CPM2A-BAT01 Battery Set (installed in CPU Unit when shipped)			

Note: The total power consumed at 5 VDC and 24 VDC must be less than 30 W.
(5 × Current consumed at 5 VDC) + (24 × Current consumed at 24 VDC) ≤ 30 W

I/O Expansion Adapters

Use Expansion I/O adapters to split the configuration into more than one group, allowing greater flexibility with mounting space as well as the use of at least 16 I/O Modules or Dedicated I/O Modules. Expansion Adapters can be used with any CQM1H CPU.

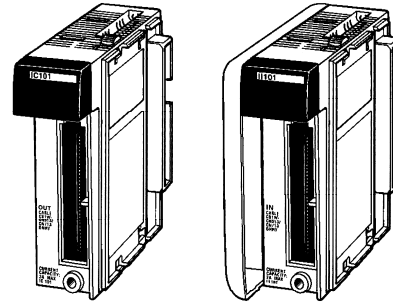

CQM1H-IC101

CQM1H-II101

■ SPECIFICATIONS

Maximum Number of Units Mountable

CPU model	CPU Block only		CPU Block + I/O Expansion Adapter		
	CPU grouping	CPU grouping			
	I/O Modules + Dedicated I/O Modules	Controller Link Modules	Inner Boards	I/O Modules + Dedicated I/O Modules	Extension grouping I/O Modules + Dedicated I/O Modules
CQM1H-CPU61	11 Modules max.	1 Module	2 Boards max.	5 Modules max.	11 Modules max.
CQM1H-CPU51		Not supported	Not supported		
CQM1H-CPU21					
CQM1H-CPU11					

■ CONFIGURATION

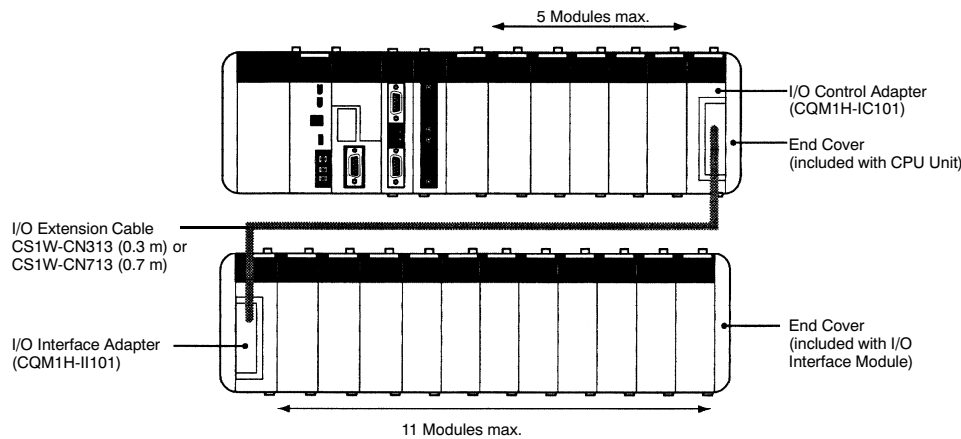

CPU Grouping
Total current consumption:
3.0 A max. (including CPU)

Extension Grouping
Total current consumption:
2.0 A max. (I/O Modules and
Dedicated I/O Modules)

Note: If the CQM1-PA203 Power Supply Unit is used, the maximum current consumption total is 3.6 A.

Memory Cassettes

An optional Memory Cassette can be used to store the user program, PLC setup, and other data in ROM so that vital data will not be lost in the event of battery expiration or careless programming/monitoring operations.

If the PLC's settings need to be changed to execute another process, the entire software setup and user program can be changed just by exchanging the Memory Cassette and rebooting the PLC.

EEPROM:

- CQM1-ME04K
- CQM1-ME04R
- CQM1-ME08K
- CQM1-ME08R

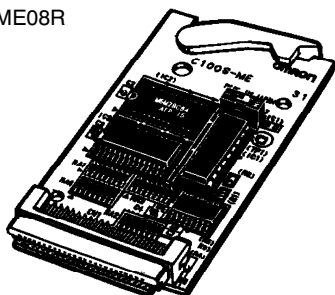

Flash Memory:

- CQM1H-ME16K
- CQM1H-ME16R

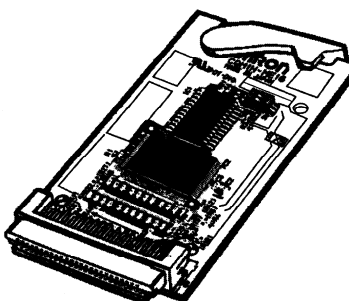

EPROM:

- CQM1-MP08K
- CQM1-MP08R

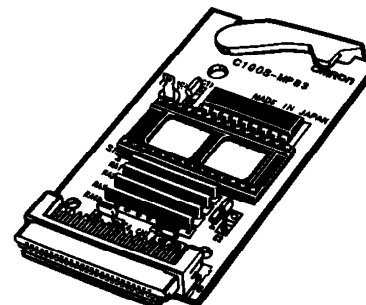

■ SPECIFICATIONS

Memory	Model	Specifications
EEPROM	CQM1-ME04K	4 kwords without clock
	CQM1-ME04R	4 kwords with clock
	CQM1-ME08K	8 kwords without clock
	CQM1-ME08R	8 kwords with clock
EPROM	CQM1-MP08K	Without clock (see below)
	CQM1-MP08R	With clock (see below)
Flash	CQM1H-ME16K	16 kwords without clock
	CQM1H-ME16R	16 kwords with clock
Memory Cassette (EEPROM or flash memory)		Mounted from the front of the CPU and used to store and read the user's program, DM (read-only DM and PLC Setup), and expansion instruction information as one block. It is possible to set the CPU so that data stored in the Memory Cassette (user's program, DM, expansion instruction information) is automatically sent to the CPU (auto-boot) at startup. Transfer and comparison of data between the CPU and Memory Cassette are possible using AR area control bits.

EPROM Chips

The following EPROM chips (sold separately) are required for EPROM Memory Cassettes. The chip is mounted in the I/O socket on the Memory Cassette.

Model	ROM version	Capacity	Access speed
ROM-ID-B	27128 or equivalent	8 kwords	150 ns
ROM-JD-B	27256 or equivalent	16 kwords	150 ns
ROM-KD-B	27512 or equivalent	32 kwords	150 ns

Inputs and Outputs for CPUs and Modules

■ I/O MEMORY ALLOCATION

I/O words are allocated to I/O Modules according to a fixed location. When the I/O Modules and Dedicated I/O Modules are connected, the I/O words will be allocated as follows.

Input Word Allocation

IR 000 to IR 015 are allocated as input bits. The first input word (IR 000), however, is allocated to the CPU's 16 built-in input points.

Note: Built-in CPU's inputs are used for interrupt processing and built-in high-speed counter inputs.

Output Word Allocation

IR 100 to IR 115 are allocated as output bits. When Output Modules or Dedicated I/O Modules are connected, words will be allocated in order starting from IR 100.

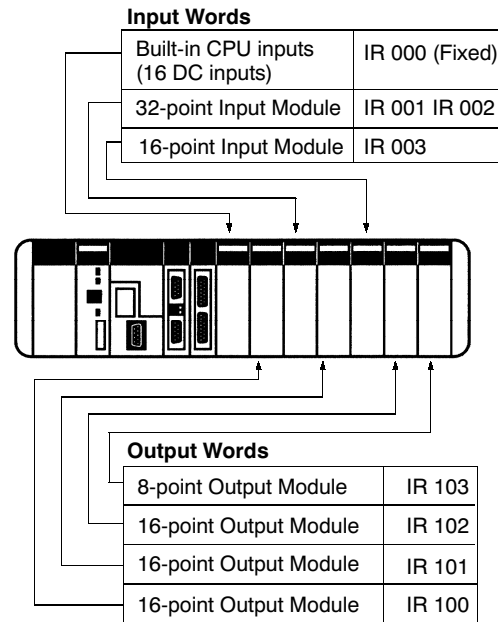

I/O Word Allocation

Module type		I/O word allocation		
		Input words	Output words	Description
Input module		1 or 2	—	Each 8-point or 16-point input module is allocated one input word and each 32-point input module is allocated two input words. Words will be allocated in order starting from IR 001.
Output modules		—	1 or 2	Each 8-point or 16-point output module is allocated one output word and each 32-point output module is allocated two output words. Words will be allocated in order starting from IR 100.
B7A Master link modules	B7A02	—	1	Depending on the module, each B7A Master link module is allocated input words and output words.
	B7A12	1	—	
	B7A03	—	1	
	B7A13	2	—	
	B7A21	1	1	
DeviceNet I/O link module		1	1	Each DeviceNet I/O link module is allocated one input word and one output word.
Profibus-DP I/O link module	IN: 32 points OUT: 32 points	2	2	The Profibus-DP master configuration data must match this setting.
	IN: 64 points OUT: 64 points	4	4	
	IN: 96 points OUT: 96 points	6	6	
	IN: 128 points OUT: 128 points	8	8	
AS-Interface master module	IN: 44 points OUT: 44 points	3	3	This setting will influence the maximum number of AS-Interface slaves that can be addressed by the PLC.
	IN: 60 points OUT: 60 points	4	4	
	IN: 92 points OUT: 92 points	6	6	
	IN: 76 points OUT: 76 points	5	5	
	IN: 92 points OUT: 92 points	6	6	
	IN: 124 points OUT: 124 points	8	8	
CompoBus/S master modules	IN: 16 points OUT: 16 points	1	1	Depending on the module, each CompoBus/S master module is allocated input words and output words.
	IN: 32 points OUT: 32 points	2	2	
	IN: 64 points OUT: 64 points	4	4	
Analog input module		2 or 4	—	Each analog input module can be set to input either 2 or 4 points. If the module is set to input 2 points, two input words are allocated. If the module is set to input 4 points, four input words are allocated.
Analog output module		—	2	Each analog output module is allocated two output words.
Analog power supply modules for CQM1-AD041 and -DA021		—	—	Power supply modules are not involved directly in I/O operations and are thus not allocated I/O words.
Temperature control modules	00□/10□	2 or 1	2 or 1	Each temperature control module is allocated two input words and two output words when two loops are used. Only one input word and one output word are allocated when one loop is used.
	20□/30□	1	1	One input word and one output word are allocated in the order the module is connected.
Safety relay module		1	—	One input word is allocated per module in the order the module is connected.

■ INPUT SPECIFICATIONS

All of the Input Modules listed in the following tables have photocoupler isolation and LED input indicators.

CPUs

Number of inputs	Input voltage	Input current	Input impedance	Operating voltage		Response times (See Note)		External connection	Inputs/common	Current consumption (5 VDC)	Weight
				ON voltage	OFF voltage	ON delay	OFF delay				
16 pts	24 VDC +10%/15%	10 mA for IN04/05 6 mA for the rest (24 VDC)	2.2 kΩ for IN04/05 3.9 kΩ for the rest	17.4 VDC min.	5.0 VDC max.	8 ms max.	8 ms max.	Terminal block	16	—	—

Note: Selectable from 1 to 128 ms in the PLC Setup.

DC Input Modules

Model	Number of inputs	Input voltage	Input current	Input impedance	Operating voltage		Response times (See Note)	
					ON voltage	OFF voltage	ON delay	OFF delay
CQM1-ID211	8 pts	12 to 24 VDC +10%/15%	10 mA (24 VDC)	2.4 kΩ	10.2 VDC min.	3.0 VDC max.	8 ms max.	8 ms max.
CQM1-ID111	16 pts	12 VDC +10%/15%	6 mA (12 VDC)	1.8 kΩ	8.0 VDC min.	3.0 VDC max.	8 ms max.	8 ms max.
CQM1-ID212	16 pts	24 VDC +10%/15%	6 mA (24 VDC)	3.9 kΩ	14.4 VDC min.	5.0 VDC max.	8 ms max.	8 ms max.
CQM1-ID112	32 pts	12 VDC +10%/15%	4 mA (12 VDC)	2.2 kΩ	8.0 VDC min.	3.0 VDC max.	8 ms max.	8 ms max.
CQM1-ID213	32 pts	24 VDC +10%/15%	4 mA (24 VDC)	5.6 kΩ	14.4 VDC min.	5.0 VDC max.	8 ms max.	8 ms max.

Note: Selectable from 1 to 128 ms in the PLC Setup.

Model	Number of inputs	External connection	Inputs/common	Current consumption (5 VDC)	Weight
CQM1-ID211	8 pts	Terminal block	8 independent commons	50 mA max.	180 g max.
CQM1-ID111	16 pts		16	85 mA max.	180 g max.
CQM1-ID212	16 pts		16	85 mA max.	180 g max.
CQM1-ID112	32 pts	Connector	32	170 mA max.	160 g max.
CQM1-ID213	32 pts		32	170 mA max.	160 g max.
CQM1-ID214	32 pts		32	170 mA max.	160 g max.

AC Input Modules

Model	Number of inputs	Input voltage	Input current	Input impedance	Operating voltage		Response times	
					ON voltage	OFF voltage	ON delay	OFF delay
CQM1-IA121	8 pts	100 to 120 VAC +10%/15%	5 mA (100 VAC)	20 kΩ (50 Hz) 17 kΩ (60 Hz)	60 VAC min.	20 VAC max.	35 ms max.	55 ms max.
CQM1-IA221	8 pts	200 to 240 VAC +10%/15%	6 mA (200 VAC)	38 kΩ (50 Hz) 32 kΩ (60 Hz)	150 VAC min.	40 VAC max.	35 ms max.	55 ms max.

Model	Number of inputs	External connection	Inputs/common	Current consumption (5 VDC)	Weight
CQM1-IA121	8 pts	Terminal block	8	50 mA max.	210 g max.
CQM1-IA221	8 pts		8	50 mA max.	210 g max.

■ INPUT CIRCUIT CONFIGURATION

CPU Inputs

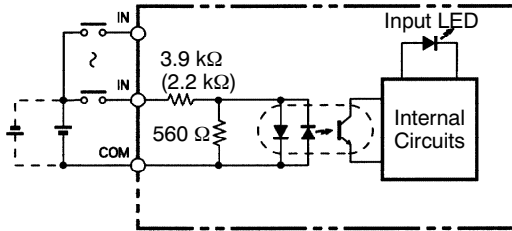

CQM1-ID211

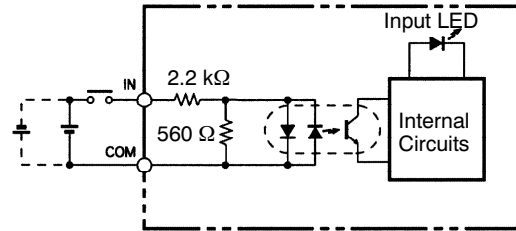

CQM1-ID111/212

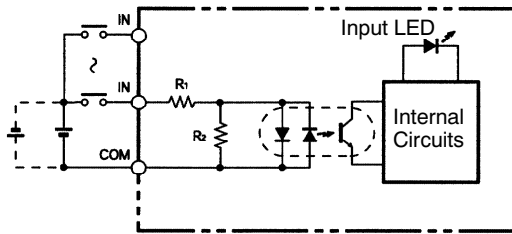

- ID111: R₁: 1.8 kΩ
R₂: 620 Ω
- ID212: R₁: 3.9 kΩ
R₂: 560 Ω

CQM1-ID112/213/214

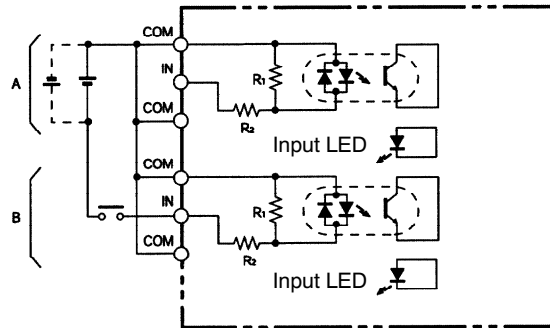

- ID112: R₁: 750 Ω
R₂: 2.2 kΩ
- ID213: R₁: 620 Ω
R₂: 5.6 kΩ
- ID214: R₁: 620 Ω
R₂: 3.9 kΩ

CQM1-IA121

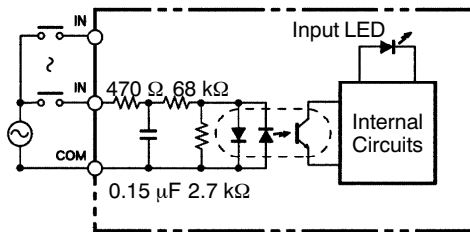

CQM1-IA221

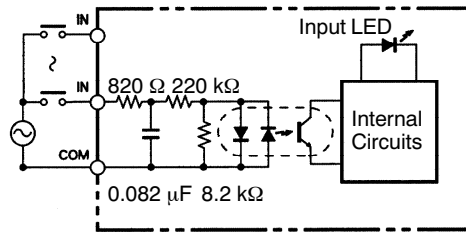

■ OUTPUT MODULE SPECIFICATIONS

All of the Output Modules have LED output indicators.

Contact Output Modules

Model	Number of outputs	Max. switching capacity	Min. switching capacity	Response times		External connector	Leakage current
				ON delay	OFF delay		
CQM1-OC221	8 pts	2 A, 250 VAC (cosφ= 1) 2 A, 250 VAC (cosφ= 0.4) 2 A, 24 VDC (16 A/Unit)	10 mA, 5 VDC	10 ms max.	5 ms max.	Terminal block	—
CQM1-OC222	16 pts	2 A, 250 VAC (cosφ= 1) 2 A, 250 VAC (cosφ= 0.4) 2 A, 24 VDC (8 A/Unit)	10 mA, 5 VDC	10 ms max.	5 ms max.		
CQM1-OC224	8 pts	2 A, 250 VAC (cosφ= 1) 2 A, 250 VAC (cosφ= 0.4) 2 A, 24 VDC (16 A/Unit)	10 mA, 5 VDC	15 ms max.	5 ms max.		

Model	Number of outputs	Outputs/common	Fuses	External power supply capacity	Internal current consumption (5 VDC)	Weight
CQM1-OC221	8 pts	Independent commons	None	—	430 mA max.	200 g max.
CQM1-OC222	16 pts	16 pts to one common		—	850 mA max.	230 g max.
CQM1-OC224	8 pts	Independent commons		—	440 mA max.	270 g max.

Transistor Output Modules

Model	Number of outputs	Max. switching capacity	Min. switching capacity	Response times		External connector	Leakage current
				ON delay	OFF delay		
CQM1-OD211 (NPN, sinking)	8 pts	2 A at 24 VDC +10%/-15% 5 A/Unit	—	0.1 ms max.	0.3 ms max.	Terminal block	0.1 mA max.
CQM1-OD212 (NPN, sinking)	16 pts	50 mA at 4.5 VDC to 300 mA at 26.4 V	—	0.1 ms max.	0.4 ms max.		0.1 mA max.
CQM1-OD213 (NPN, sinking)	32 pts	16 mA at 4.5 VDC to 100 mA at 26.4 V	—	0.1 ms max.	0.4 ms max.	Connector	0.1 mA max.
CQM1-OD214 (PNP, sourcing)	16 pts	50 mA at 4.5 VDC to 300 mA at 26.4 V	—	0.1 ms max.	0.4 ms max.	Terminal block	0.1 mA max.
CQM1-OD215 (PNP, sourcing)	8 pts	1.0 A at 24 VDC +10%/-15% 4 A/Unit	—	0.2 ms max.	0.8 ms max.		0.1 mA max.
CQM1-OD216 (PNP, sourcing)	32 pts	0.5 A at 24 VDC +10%/-15% 5 A/Unit	—	0.1 ms max.	0.3 ms max.	Connector	0.1 mA max.

Model	Number of outputs	Outputs/common	Fuses (See Note)	External power supply capacity	Internal current consumption (5 VDC)	Weight
CQM1-OD211 (NPN, sinking)	8 pts	8	7 A (one fuse/common)	24 VDC +10%/-15% 15 mA min.	90 mA max.	200 g max.
CQM1-OD212 (NPN, sinking)	16 pts	16	5 A (one fuse/common)	5 to 24 VDC ±10% 40 mA min.	170 mA max.	180 g max.
CQM1-OD213 (NPN, sinking)	32 pts	32	3.5 A (one fuse/common)	5 to 24 VDC ±10% 110 mA min.	240 mA max.	180 g max.
CQM1-OD214 (PNP, sourcing)	16 pts	16	3.5 A (two fuses/common)	5 to 24 VDC ±10% 60 mA min.	170 mA max.	210 g max.
CQM1-OD215 (PNP, sourcing)	8 pts	8	Short-circuit protection function	24 VDC +10%/-15% 24 mA min.	110 mA max.	240 g max.
CQM1-OD216 (PNP, sourcing)	32 pts	32	7 A (one fuse/common)	24 VDC +10%/-15% 160 mA min.	240 mA max.	210 g max.

Note: Fuses are not user-serviceable.

AC Output Modules

Model	Number of outputs	Max. switching capacity	Min. switching capacity	Response times		External connector	Leakage current
				ON delay	OFF delay		
CQM1-OA221	8 pts	0.4 A at 100 to 240 VAC	—	6 ms max.	1/2 cycle + 5 ms max.	Terminal block	1 mA max. at 100 VAC, 2 mA max. at 200 VAC
CQM1-OA222	6 pts	0.4 A at 100 to 240 VAC	100 mA at 10 VAC 50 mA at 24 VAC 10 mA at 100 VAC 10 mA at 240 VAC	1 ms max.	Load frequency of 1/2 cycle + 1 ms max.		

Model	Number of outputs	Outputs/common	Fuses (See note)	External power supply capacity	Internal current consumption (5 VDC)	Weight
CQM1-OA221	8 pts	4 each (2 circuits)	2 A (one fuse/common)	—	110 mA max.	240 g max.
CQM1-OA222	6 pts	4 and 2 (2 circuits)	5 A (one fuse/common)	—	250 mA max.	240 g max.

Note: Fuses are not user-serviceable.

OUTPUT CIRCUIT CONFIGURATION

CQM1-OC221

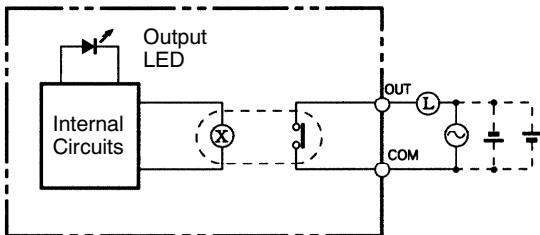

CQM1-OC222

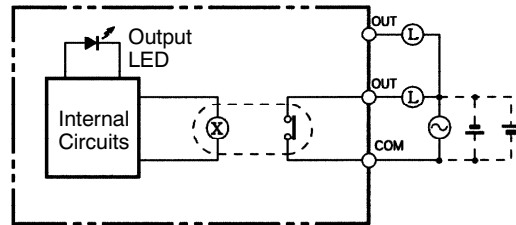

CQM1-OD211

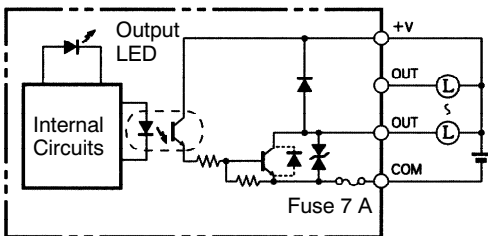

CQM1-OC224

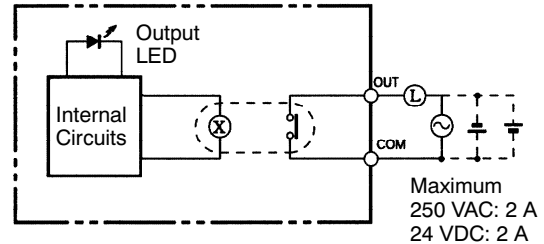

CQM1-OD212

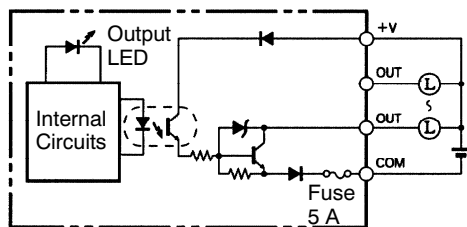

CQM1-OD214

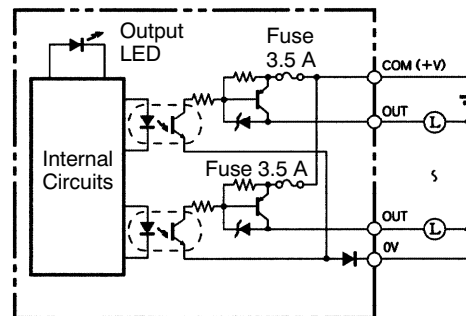

(Output Circuit Configuration continues on the next page.)

CQM1-OD213

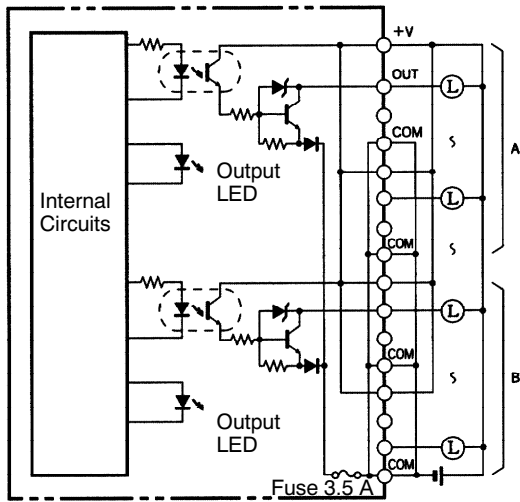

CQM1-OA221

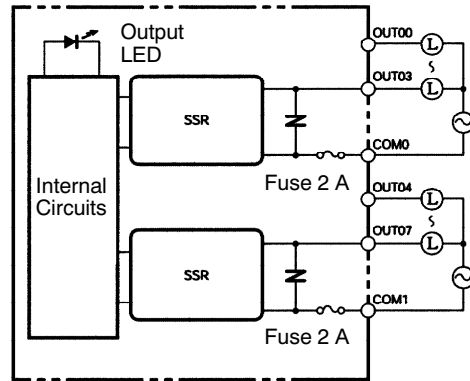

CQM1-OD215

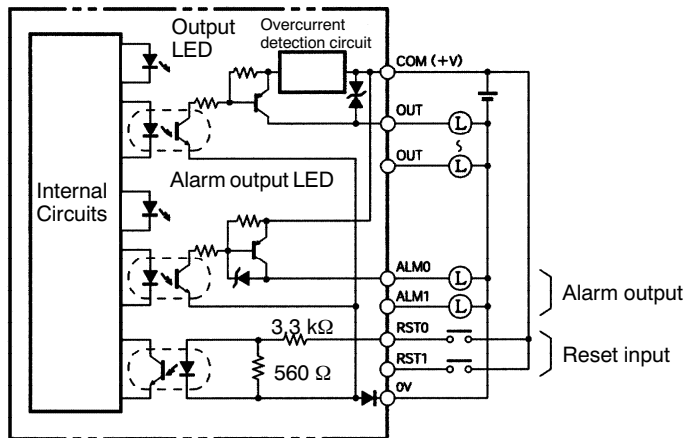

CQM1-OA222

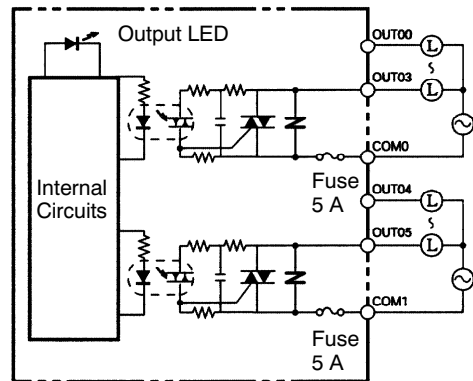

CQM1-OD216

