

Connector: SMA Jack (Female Socket)			
Termination: PCB Board Edge, End Launch; Panel Mount			
Part Number		CON SMA003.062-L	CON SMA003.062-L-G
Connector Part	Material	Finish	Finish
Bodies	Body: Brass	Nickel	Gold
	Shell: Brass	Nickel	Gold
	Nut: Brass	Nickel	Gold
	Washer: Brass	Nickel	Gold
Center Contact	Socket: Be Cu	Gold	Gold
Insulator	PTFE	-	-

REVISIONS			
REV	DESCRIPTION	DATE	APPV
A	INITIAL RELEASE OF LINX INTERNAL DRAWING	01/MAR/19	CLL

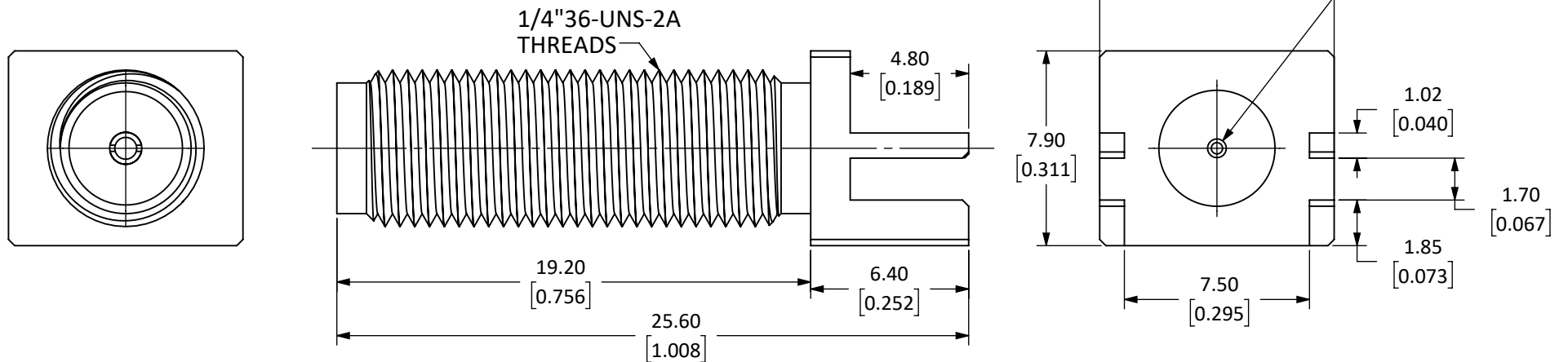

NOTES: (UNLESS OTHERWISE SPECIFIED)

1. ALL DIMENSIONS ARE IN mm [INCHES].
2. DIMENSIONS APPLY AFTER FINISHING.
3. MANUFACTURE TO BE COMPLIANT WITH EU RoHS DIRECTIVE, USE MATERIALS THAT DO NOT CONTAIN REACH SUBSTANCES OF VERY HIGH CONCERN >1000ppm, AND USE DRC CONFLICT-FREE SOURCED MATERIALS.
4. SAFETY BREAK ALL SHARP CORNERS AND EDGES 0.5 MAXIMUM.
5. SEE TABLE I FOR ELECTRICAL SPECIFICATIONS. (SHEET 2)
6. SEE TABLE II FOR ENVIRONMENTAL SPECIFICATIONS. (SHEET 2)
7. SEE TABLE III FOR MECHANICAL SPECIFICATIONS. (SHEET 2)
8. SEE PARTSLIST. "*" INDICATES FINISH TYPE.

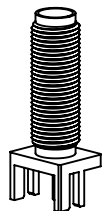

SCALE 1 : 1

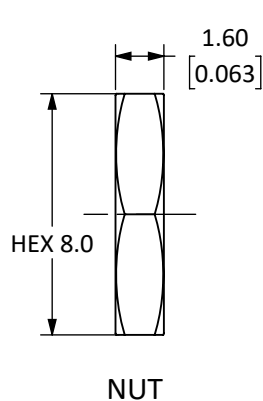

NUT

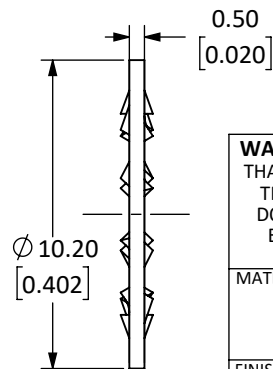

WASHER

WARNING: THIS DRAWING CONTAINS PROPRIETARY INFORMATION THAT IS THE SOLE PROPERTY OF LINX TECHNOLOGIES, AND SHALL BE TREATED AS SUCH. NO DISCLOSURE OR REPRODUCTION OF THIS DOCUMENT IS PERMITTED, IN WHOLE OR IN PART, WITHOUT THE EXPRESS WRITTEN PERMISSION OF LINX TECHNOLOGIES OR ITS DESIGNATED AGENTS.

MATERIAL:	TOLERANCES: 0.50 [.020]-5.00 [.200]= ±0.20 [.008] 5.00 [.200]-30.00 [1.200]= ±0.40 [.016] 30.0 [1.20]-120.0 [4.75]= ±0.60 [0.24] 120.0 [4.75]-315.0 [12.40]= ±1.0 [.040]	PROJECTION:  ANGLES: ±1°
FINISH:	DRAWN: M. SCHULTE	DT: 21/JAN/19
	ENGR: D. VARATHARAJAN	DT: 08/MAR/19



TITLE:
**SMA FEMALE EDGE MOUNT FOR
0.062" THICK BOARD, EXTENDED**

SIZE	DWG. NO.	REV
A	CON SMA003.062-L-*	A
SCALE: 4:1	DO NOT SCALE DRAWING	SHEET 1 OF 2

5 TABLE I

Electrical Data	Detail	
	CON SMA003.062-L	CON SMA003.062-L-G
Impedance	50 Ω	50 Ω
Frequency Range	0 to 18 GHz	0 to 18 GHz
Insulation Resistance	5 000 M Ω min.	—
Voltage Rating	1 000 V RMS	500 V RMS
Contact Resistance	Center: \leq 3.0 m Ω Outer: \leq 2.5 m Ω	Center: \leq 2.0 m Ω Outer: \leq 2.0 m Ω
VSWR	—	\leq 1.2 : 1 @ 6 GHz

6 TABLE II

Environmental Data	Detail
Corrosion (Salt spray)	ASTMB-117
Thermal Shock	MIL-STD-202 Method 107 test condition B
Vibration	MIL-STD-202 Method 204 test condition D
Mechanical Shock	MIL-STD-202 Method 213 test condition I
Temperature Range	-65 °C to +165 °C
Environmental Compliance	RoHS

7 TABLE III

Mechanical Data	Detail
Mounting Type	PCB Board Edge, End Launch; Panel Mount
Fastening Type	1/4"-36 Threaded Coupling
Interface In Accordance With	MIL-STD 348A
Recommended Torque	0.57 N·m (5.0 in·lbs)
Coupling Nut Retention	60 lbs. min.
Connector Durability	500 cycles min.
Weight	4.1 g (0.15 oz)

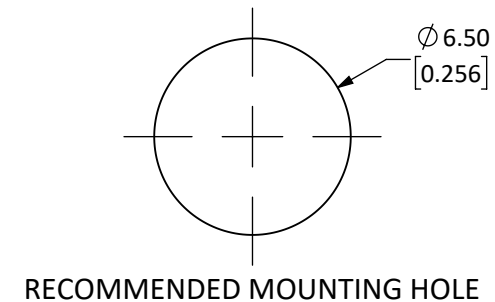
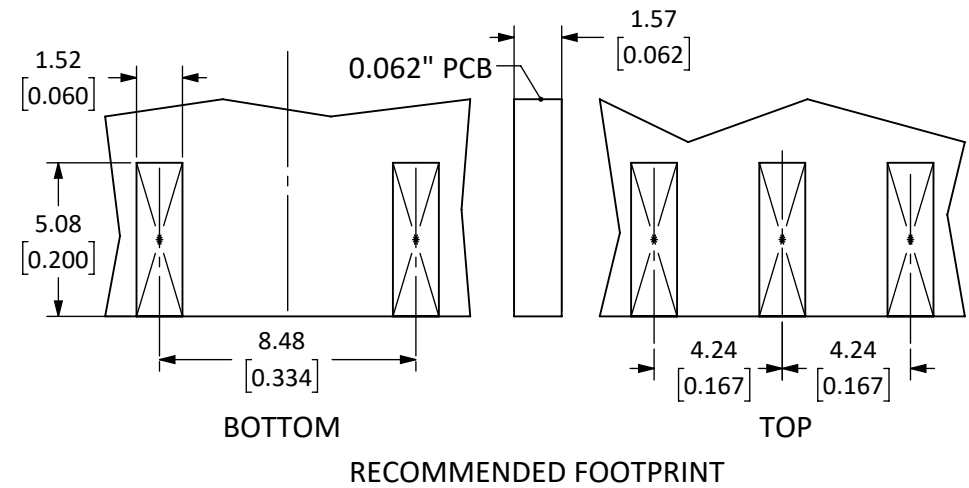

SIZE	DWG. NO.	REV
A	CON SMA003.062-L-*	A
SCALE: 4:1	DO NOT SCALE DRAWING	SHEET 2 OF 2

Solder Reflow Practices - Connectors

Application Note AN-00504

Reflow Soldering

Reflow soldering is the most common method of attaching surface mount electronic components to a circuit board. The goal of the reflow process is to melt the solder and heat the conductive surfaces, without overheating or damaging any electrical components. In the conventional reflow soldering process, there are four distinct stages, or zones, having specific thermal profiles: preheat, thermal soak, reflow, and cooling. For high-volume assembly, surface mount components are generally auto-placed by machine.

Reflow Temperature Profile

The single most critical stage in the automated assembly process is the reflow stage. The reflow profile for any given component should be closely followed because excessive temperatures or transport times during reflow can irreparably damage the component. Assembly personnel need to pay careful attention to the oven's profile to ensure that it meets the requirements necessary to successfully reflow all components while still remaining within the limits mandated by components requiring shorter flow periods.

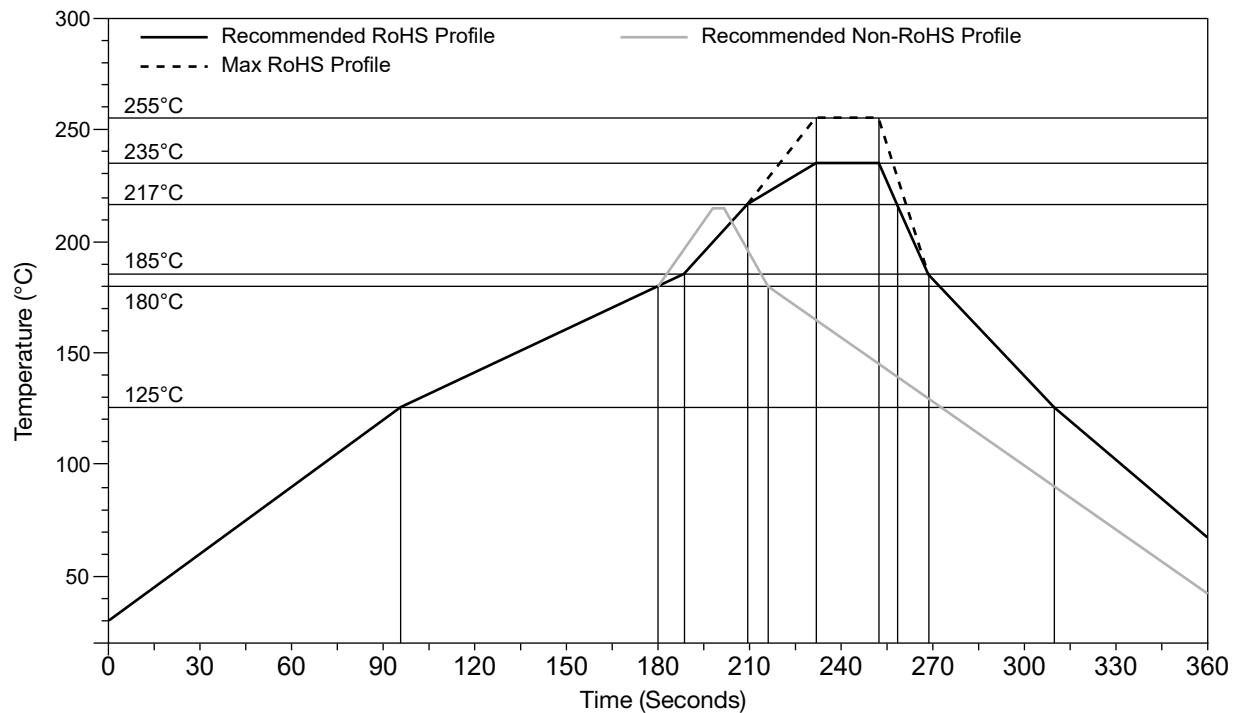

TE TECHNICAL SUPPORT CENTER

USA:	+1 (800) 522-6752
Canada:	+1 (905) 475-6222
Mexico:	+52 (0) 55-1106-0800
Latin/S. America:	+54 (0) 11-4733-2200
Germany:	+49 (0) 6251-133-1999
UK:	+44 (0) 800-267666
France:	+33 (0) 1-3420-8686
Netherlands:	+31 (0) 73-6246-999
China:	+86 (0) 400-820-6015

te.com

TE Connectivity, TE, TE connectivity (logo), Linx and Linx Technologies are trademarks owned or licensed by the TE Connectivity Ltd. family of companies. All other logos, products and/or company names referred to herein might be trademarks of their respective owners.

The information given herein, including drawings, illustrations and schematics which are intended for illustration purposes only, is believed to be reliable. However, TE Connectivity makes no warranties as to its accuracy or completeness and disclaims any liability in connection with its use. TE Connectivity's obligations shall only be as set forth in TE Connectivity's Standard Terms and Conditions of Sale for this product and in no case will TE Connectivity be liable for any incidental, indirect or consequential damages arising out of the sale, resale, use or misuse of the product. Users of TE Connectivity products should make their own evaluation to determine the suitability of each such product for the specific application.

TE Connectivity warrants to the original end user customer of its products that its products are free from defects in material and workmanship. Subject to conditions and limitations TE Connectivity will, at its option, either repair or replace any part of its products that prove defective because of improper workmanship or materials. This limited warranty is in force for the useful lifetime of the original end product into which the TE Connectivity product is installed. Useful lifetime of the original end product may vary but is not warranted to exceed one (1) year from the original date of the end product purchase.

©2023 TE Connectivity. All Rights Reserved.

05/23 Original