

# CMPA5585030D

30 W, 5.5 - 8.5 GHz, GaN MMIC, Power Amplifier

## Description

Cree's CMPA5585030D is a gallium nitride (GaN) High Electron Mobility Transistor (HEMT) based monolithic microwave integrated circuit (MMIC). GaN has superior properties compared to silicon or gallium arsenide, including higher breakdown voltage, higher saturated electron drift velocity and higher thermal conductivity. GaN HEMTs also offer greater power density and wider bandwidths compared to Si and GaAs transistors. This MMIC contains a two-stage reactively matched amplifier design approach enabling very wide bandwidths to be achieved.

## Typical Performance Over 5.5-8.5 GHz ( $T_c = 25^\circ\text{C}$ )

Parameter	5.5 GHz	6.5 GHz	7.5 GHz	8.5 GHz	Units
Small Signal Gain	32.5	29.7	30.1	29.5	dB
$P_{OUT}$ @ $P_{IN} = 26$ dBm	61.2	55.1	57.3	53.8	W
Power Gain @ $P_{IN} = 26$ dBm	21.9	21.4	21.6	21.3	dB
PAE @ $P_{IN} = 26$ dBm	44	40	45	44	%

### Features

- 30 dB Small Signal Gain
- 50 W Typical  $P_{SAT}$
- Operation up to 28 V
- High Breakdown Voltage
- High Temperature Operation
- Size 0.142 x 0.188 x 0.004 inches

### Applications

- Point to Point Radio
- Communications
- Test Instrumentation
- EMC Amplifier Drivers

**Absolute Maximum Ratings (not simultaneous) at 25 °C**

Parameter	Symbol	Rating	Units	Conditions
Drain source Voltage	$V_{DSS}$	84	$V_{DC}$	25 °C
Gate source Voltage	$V_{GS}$	-10, +2	$V_{DC}$	25 °C
Storage Temperature	$T_{STG}$	-55, +150	°C	°C
Operating Junction Temperature	$T_J$	225	°C	°C
Thermal Resistance, Junction to Case (packaged) <sup>1</sup>	$R_{\theta JC}$	2.7	°C/W	CW, 85 °C, $P_{DISS} = 37.5$ W
Mounting Temperature (30 seconds)	$T_S$	320	°C	°C

Note:

<sup>1</sup> Eutectic die attach using 80/20 AuSn mounted to a 40 mil thick CPC carrier**Electrical Characteristics (Frequency = 5.5 GHz to 8.5 GHz unless otherwise stated;  $T_c = 25$  °C)**

Characteristics	Symbol	Min.	Typ.	Max.	Units	Conditions
<b>DC Characteristics</b>						
Gate Threshold Voltage	$V_{GS(TH)}$	-3.8	-3.0	-2.3	V	$V_{DS} = 10$ V, $I_D = 12.7$ mA
Gate Quiescent Voltage	$V_{GS(Q)}$	-	-2.7	-	$V_{DC}$	$V_{DD} = 28$ V, $I_{DQ} = 800$ mA
Saturated Drain Current <sup>1</sup>	$I_{DS}$	9.2	12.7	-	A	$V_{DS} = 6.0$ V, $V_{GS} = 2.0$ V
Drain-Source Breakdown Voltage	$V_{BD}$	84	-	-	V	$V_{GS} = -8$ V, $I_D = 12.7$ mA
<b>RF Characteristics<sup>2</sup></b>						
Small Signal Gain	S21	23.7	32.3	-	dB	$V_{DD} = 28$ V, $I_{DQ} = 800$ mA, $f = 5.5$ GHz
Small Signal Gain	S21	23.1	29.6	-	dB	$V_{DD} = 28$ V, $I_{DQ} = 800$ mA, $f = 6.5$ GHz
Small Signal Gain	S21	23.1	29.8	-	dB	$V_{DD} = 28$ V, $I_{DQ} = 800$ mA, $f = 8.5$ GHz
Output Power	$P_{OUT}$	46.8	58.9	-	W	$V_{DD} = 28$ V, $I_{DQ} = 800$ mA, $P_{IN} = 26$ dBm, $f = 5.5$ GHz
Output Power	$P_{OUT}$	40.7	53.7	-	W	$V_{DD} = 28$ V, $I_{DQ} = 800$ mA, $P_{IN} = 26$ dBm, $f = 6.5$ GHz
Output Power	$P_{OUT}$	40.7	51.3	-	W	$V_{DD} = 28$ V, $I_{DQ} = 800$ mA, $P_{IN} = 26$ dBm, $f = 8.5$ GHz
Power Added Efficiency	PAE	34	45	-	%	$V_{DD} = 28$ V, $I_{DQ} = 800$ mA, $P_{IN} = 26$ dBm, $f = 5.5$ GHz
Power Added Efficiency	PAE	30	41	-	%	$V_{DD} = 28$ V, $I_{DQ} = 800$ mA, $P_{IN} = 26$ dBm, $f = 6.5$ GHz
Power Added Efficiency	PAE	36	39	-	%	$V_{DD} = 28$ V, $I_{DQ} = 800$ mA, $P_{IN} = 26$ dBm, $f = 8.5$ GHz
Power Gain	$G_P$	-	21.5	-	dB	$V_{DD} = 28$ V, $I_{DQ} = 800$ mA, $P_{IN} = 26$ dBm
Input Return Loss	S11	-	10	-	dB	$V_{DD} = 28$ V, $I_{DQ} = 800$ mA
Output Return Loss	S22	-	10	-	dB	$V_{DD} = 28$ V, $I_{DQ} = 800$ mA
Output Mismatch Stress	VSWR	-	5:1	-	$\Psi$	No damage at all phase angles, $V_{DD} = 28$ V, $I_{DQ} = 800$ mA, $P_{OUT} = 25$ W CW

Notes:

<sup>1</sup> Scaled from PCM data<sup>2</sup> All data pulse tested on-wafer with Pulse Width = 10  $\mu$ s, Duty Cycle = 0.1%

**DIE Dimensions (units in microns)**

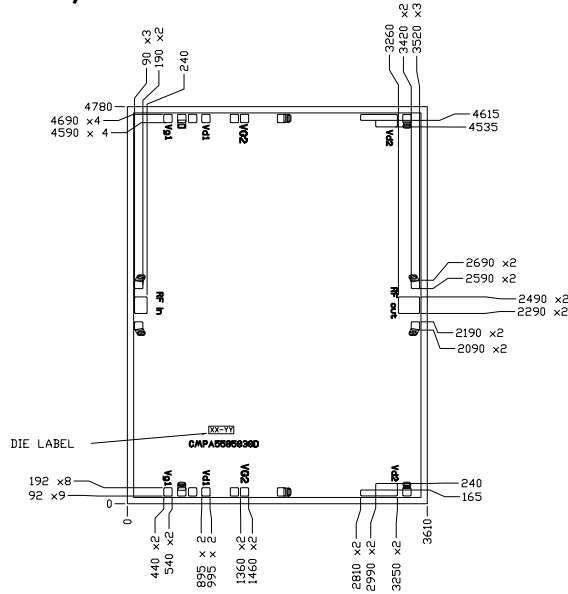

Overall die size 3610 x 4780 (+0/-50) microns, die thickness 100 (+/-10) micron.  
 All Gate and Drain pads must be wire bonded for electrical connection.

Pad	Function	Description	Pad Size (microns)	Note
1	RF-IN	RF-Input pad. Matched to 50 ohm.	150 x 200	3
2	VG1_A	Gate control for stage 1. $V_G \sim 2.0 - 3.5 V$ .	100 x 100	1,2
3	VG1_B	Gate control for stage 1. $V_G \sim 2.0 - 3.5 V$ .	100 x 100	1,2
4	VD1_A	Drain supply for stage 1. $V_D = 28 V$ .	100 x 100	1
5	VD1_B	Drain supply for stage 1. $V_D = 28 V$ .	100 x 100	1
6	VG2_A	Gate control for stage 2A. $V_G \sim 2.0 - 3.5 V$ .	100 x 100	1,3
7	VG2_B	Gate control for stage 2A. $V_G \sim 2.0 - 3.5 V$ .	100 x 100	1,3
8	VD2_A	Drain supply for stage 2A. $V_D = 28 V$ .	-	1
9	VD2_B	Drain supply for stage 2B. $V_D = 28 V$ .	-	1
10	RF-Out	RF-Output pad. Matched to 50 ohm.	250 x 200	3

- Note 1: Attach bypass capacitor to pads 2-9 per application circuit
- Note 2: VG1\_A and VG1\_B are connected internally so it would be enough to connect either one for proper operation
- Note 3: VG2\_A and VG2\_B are connected internally so it would be enough to connect either one for proper operation
- Note 4: The RF Input and Output pad have a ground-signal-ground with a nominal pitch of 10 mil (250 um). The RF ground pads are 100 x 100 microns

**Die Assembly Notes:**

- Recommended solder is AuSn (80/20) solder. Refer to Cree’s website for the Eutectic Die Bond Procedure application note at [http://www.cree.com/products/wireless\\_documents.asp](http://www.cree.com/products/wireless_documents.asp)
- Vacuum collet is the preferred method of pick-up
- The backside of the die is the Source (ground) contact
- Die back side gold plating is 5 microns thick minimum
- Thermosonic ball or wedge bonding are the preferred connection methods
- Gold wire must be used for connections
- Use the die label (XX-YY) for correct orientation



**Block Diagram Showing Additional Capacitors for Operation Over 5.5 to 8.5 GHz**

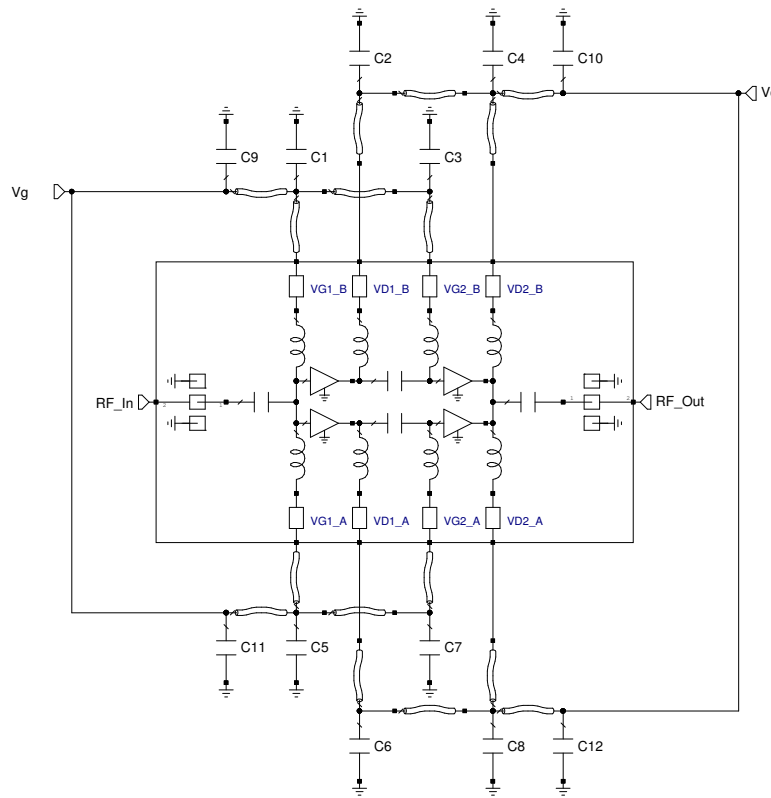

Designator	Description	Qty
C1,C2,C3,C4,C5,C6,C7,C8	CAP, 51pF, +/-10%, SINGLE LAYER, 0.035", Er 3300, 100V, Ni/Au TERMINATION	8
C9,C10,C11,C12	CAP, 680pF, +/-10%, SINGLE LAYER, 0.070", Er 3300, 100V, Ni/Au TERMINATION	4

Notes:

<sup>1</sup> The input, output and decoupling capacitors should be attached as close as possible to the die- typical distance is 5 to 10 mils with a maximum of 15 mils.

<sup>2</sup> The MMIC die and capacitors should be connected with 2 mil gold bond wires.



### Typical Performance of the CMPA5585030D

**Figure 1. Typical S-Parameters**  
 $V_{DD} = 28\text{ V}, I_{DQ} = 0.8\text{ A}$

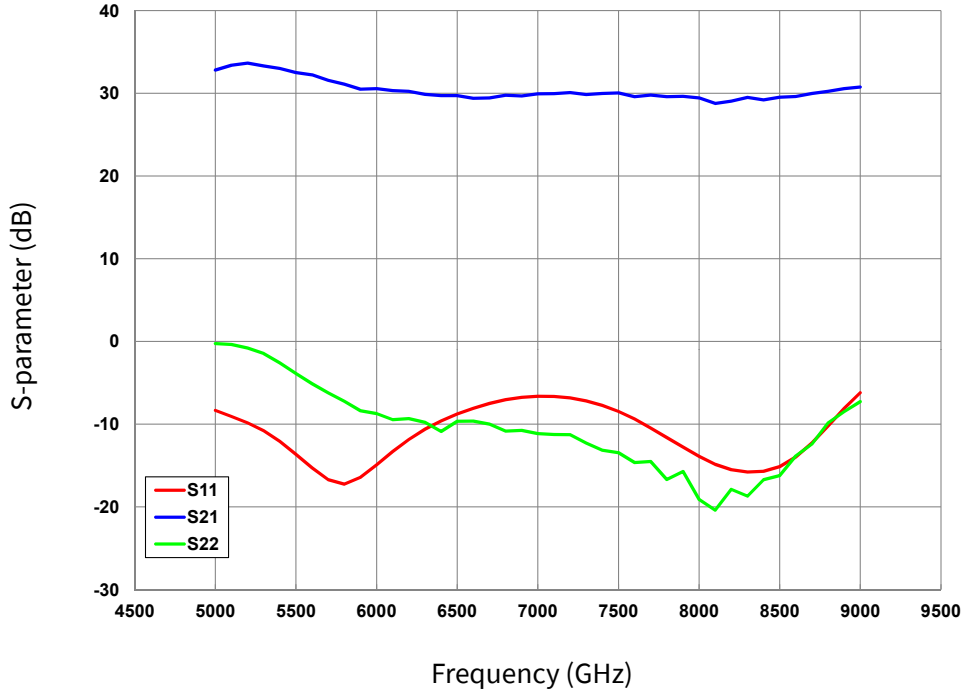

**Figure 2. Frequency & PAE**  
 $V_{DD} = 28\text{ V}, I_{DQ} = 0.8\text{ A}$

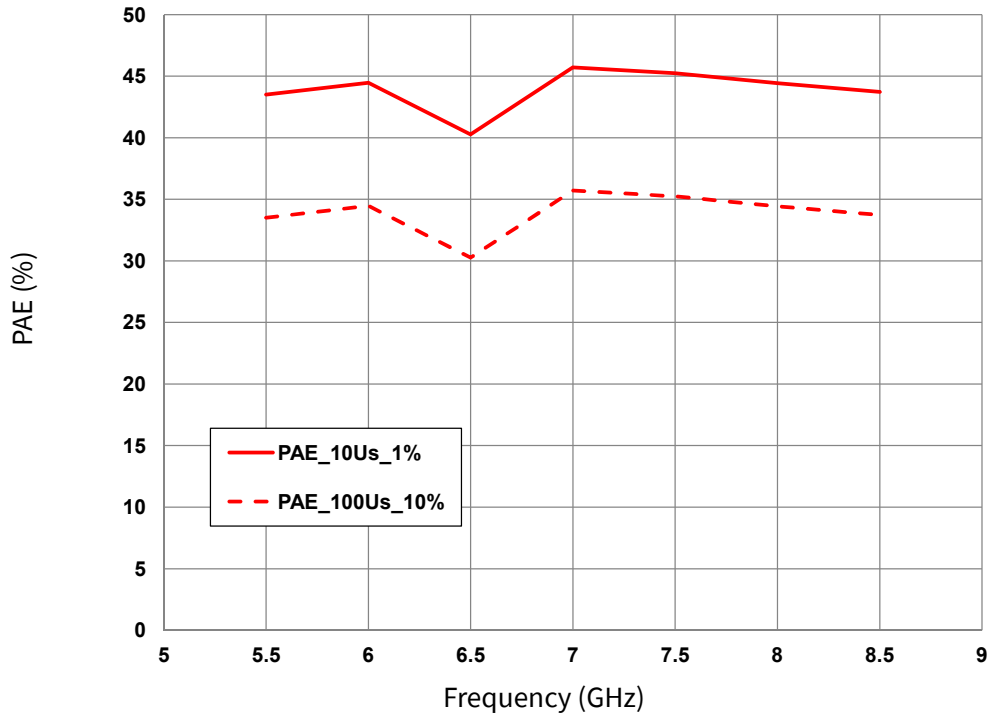



**Typical Performance of the CMPA5585030D**

**Figure 3. Output Power @  $P_{IN} = 26$  dBm vs Frequency**  
 $V_{DD} = 28$  V,  $I_{DQ} = 0.8$  A

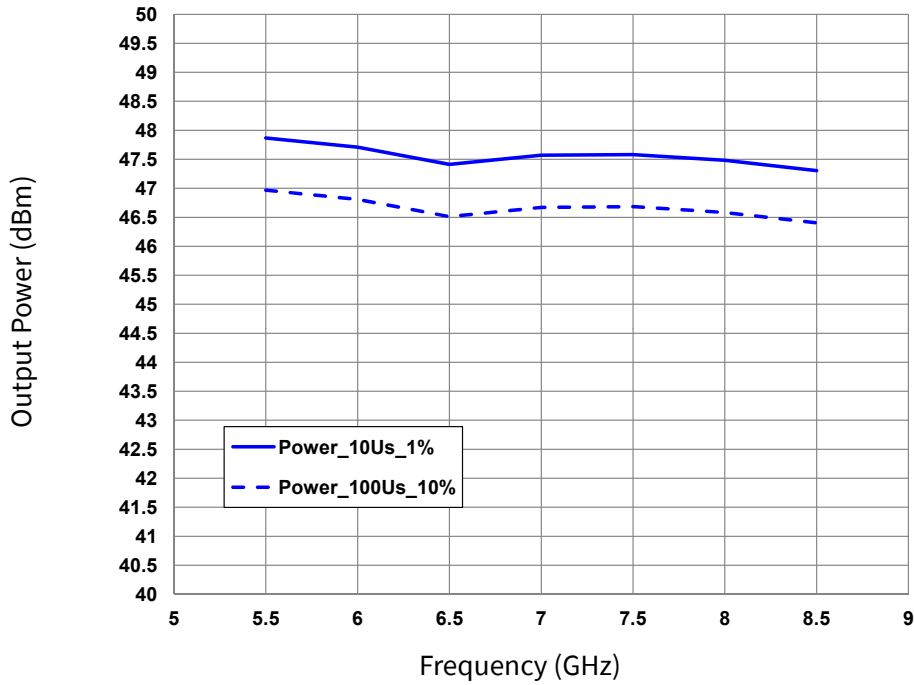

**Figure 4. Power Gain @  $P_{IN} = 26$  dBm vs Frequency**  
 $V_{DD} = 28$  V,  $I_{DQ} = 0.8$  A

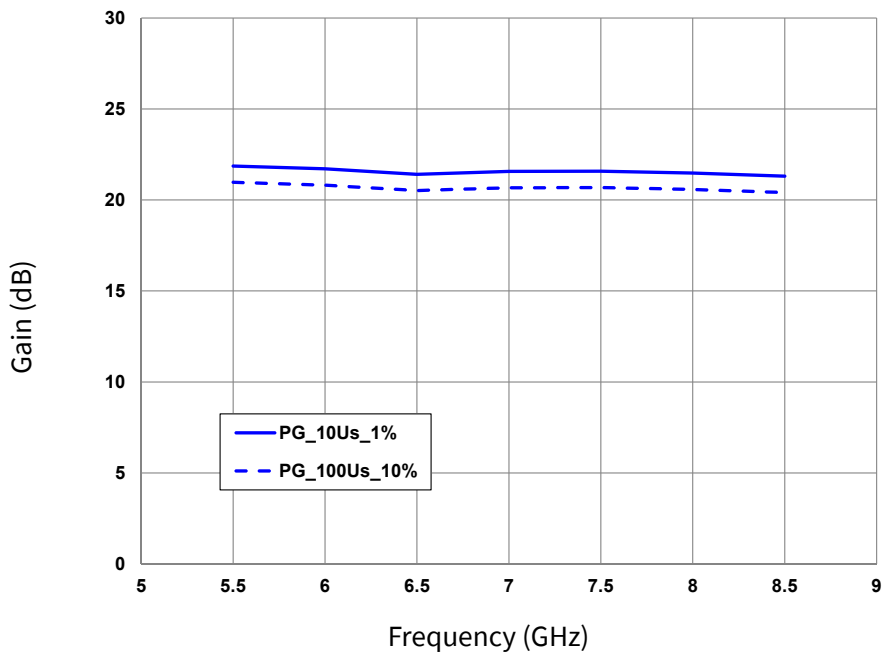



**Part Number System**

**CMPA5585030D**

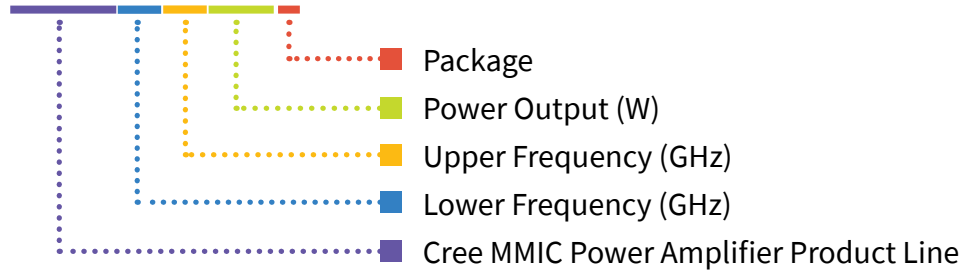

**Table 1.**

Parameter	Value	Units
Lower Frequency	5.5	GHz
Upper Frequency <sup>1</sup>	8.5	GHz
Power Output	30	W
Package	Bare Die	-

**Note<sup>1</sup>:** Alpha characters used in frequency code indicate a value greater than 9.9 GHz. See Table 2 for value.

**Table 2.**

Character Code	Code Value
A	0
B	1
C	2
D	3
E	4
F	5
G	6
H	7
J	8
K	9
Examples:	1A = 10.0 GHz 2H = 27.0 GHz

CMPA5585030D



### Product Ordering Information

Order Number	Description	Unit of Measure
CMPA5585030D	GaN HEMT	Each



For more information, please contact:

4600 Silicon Drive  
Durham, North Carolina, USA 27703  
[www.wolfspeed.com/RF](http://www.wolfspeed.com/RF)

Sales Contact  
RFSales@cree.com

## Notes

---

### Disclaimer

Specifications are subject to change without notice. “Typical” parameters are the average values expected by Cree in large quantities and are provided for information purposes only. Cree products are not warranted or authorized for use as critical components in medical, life-saving, or life-sustaining applications, or other applications where a failure would reasonably be expected to cause severe personal injury or death. No responsibility is assumed by Cree for any infringement of patents or other rights of third parties which may result from use of the information contained herein. No license is granted by implication or otherwise under any patent or patent rights of Cree.