

CMPA0527005F

5 W, 0.5 - 2.7 GHz, 50 V, GaN HEMT

Description

CMPA0527005F is packaged gallium nitride (GaN) High Electron Mobility Transistor (HEMT) based monolithic microwave integrated circuit (MMIC). This device is matched to 50 ohms at the input and unmatched at the output. This device operates from a 50 V rail and is intended to be used as a predriver from 0.5 to 2.7 GHz. The transistor is available in a 6 leaded flange package.

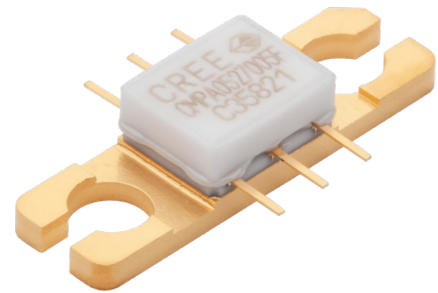

Package Types: 440221
PN: CMPA0527005F

Typical Performance Over 0.5 - 2.7 GHz ($T_c = 25^\circ\text{C}$), 50 V, $P_{IN} = 24\text{ dBm}$, CW

Parameter	0.5 GHz	1.0 GHz	1.5 GHz	2.0 GHz	2.7 GHz	Units
Small Signal Gain	20.4	20.8	21	20.5	19.5	dB
Output Power	7.8	9.3	9.1	8.7	6.6	W
Drain Efficiency	58.5	53.8	49.2	47.1	41.5	%

Note: Measured in the CMPA0527005F-AMP1 application circuit

Features

- Up to 2.7 GHz Operation
- 8 W Typical Output Power
- 20 dB Small Signal Gain
- Application Circuit for 0.5 - 2.7 GHz
- 50% Efficiency
- 50 V Operation

 Large Signal Models Available for ADS and MWO

RoHS
COMPLIANT



Absolute Maximum Ratings (not simultaneous) at 25 °C Case Temperature

Parameter	Symbol	Rating	Units	Conditions
Drain-Source Voltage	V_{DSS}	150	Volts	25 °C
Gate-to-Source Voltage	V_{GS}	-10, +2	Volts	25 °C
Storage Temperature	T_{STG}	-65, +150	°C	
Operating Junction Temperature	T_J	225	°C	
Maximum Forward Gate Current	I_{GMAX}	1.2	mA	25 °C
Maximum Drain Current ¹	I_{DMAX}	0.5	A	25 °C
Soldering Temperature ²	T_S	245	°C	
Screw Torque	τ	40	in-oz	
Thermal Resistance, Junction to Case ³	$R_{\theta JC}$	18	°C/W	85 °C
Case Operating Temperature ⁴	T_C	-40, +75	°C	

Notes:

¹ Current limit for long term, reliable operation

² Refer to the Application Note on soldering at wolfspeed.com/rf/document-library

³ Measured for the CMPA0527005F at $P_{DISS} = 8.4$ W

⁴ See also, Power Derating Curve on Page 5

Electrical Characteristics ($T_C = 25$ °C)

Characteristics	Symbol	Min.	Typ.	Max.	Units	Conditions
DC Characteristics¹						
Gate Threshold Voltage	$V_{GS(th)}$	-3.8	-3.0	-2.3	V_{DC}	$V_{DS} = 10$ V, $I_D = 1.2$ mA
Gate Quiescent Voltage	$V_{GS(Q)}$	-	-2.7	-	V_{DC}	$V_{DS} = 50$ V, $I_D = 0.11$ A
Saturated Drain Current ²	I_{DS}	0.78	1.12	-	A	$V_{DS} = 6.0$ V, $V_{GS} = 2.0$ V
Drain-Source Breakdown Voltage	V_{BR}	100	-	-	V_{DC}	$V_{GS} = -8$ V, $I_D = 1.2$ mA
RF Characteristics^{3,4,5} ($T_C = 25$ °C, $F_0 = 2.7$ GHz unless otherwise noted)						
Small Signal Gain	S21	17	18.5	-	dB	$V_{DD} = 50$ V, $I_{DQ} = 0.11$ A $P_{IN} = 10$ dBm
Power Gain	G_P	-	13.5	-	dB	$V_{DD} = 50$ V, $I_{DQ} = 0.11$ A
Output Power	P_{OUT}	38.6	39.5	-	dBm	$V_{DD} = 50$ V, $I_{DQ} = 0.11$ A
Drain Efficiency	η	49	58.0	-	%	$V_{DD} = 50$ V, $I_{DQ} = 0.11$ A
Output Mismatch Stress	VSWR	-	-	10:1	Ψ	No damage at all phase angles, $V_{DD} = 50$ V, $I_{DQ} = 0.11$ A, $P_{OUT} = 5$ W CW
Dynamic Characteristics⁶						
Output Capacitance	C_{DS}	-	0.8	-	pF	$V_{DS} = 50$ V, $V_{GS} = -8$ V, $f = 1$ MHz

Notes:

¹ Measured on-wafer prior to packaging.

² Scaled from PCM data

³ Measured in Cree’s production test fixture

⁴ $P_{IN} = 26$ dBm

⁵ CW

⁶ Includes package



CMPA0527005F Typical Performance in CMPA0527005F-AMP1 Application Circuit

Figure 1. Small Signal Gain, Return Losses versus Frequency of the CMPA0527005F
 $V_{DD} = 50\text{ V}, I_{DQ} = 0.110\text{ A}$

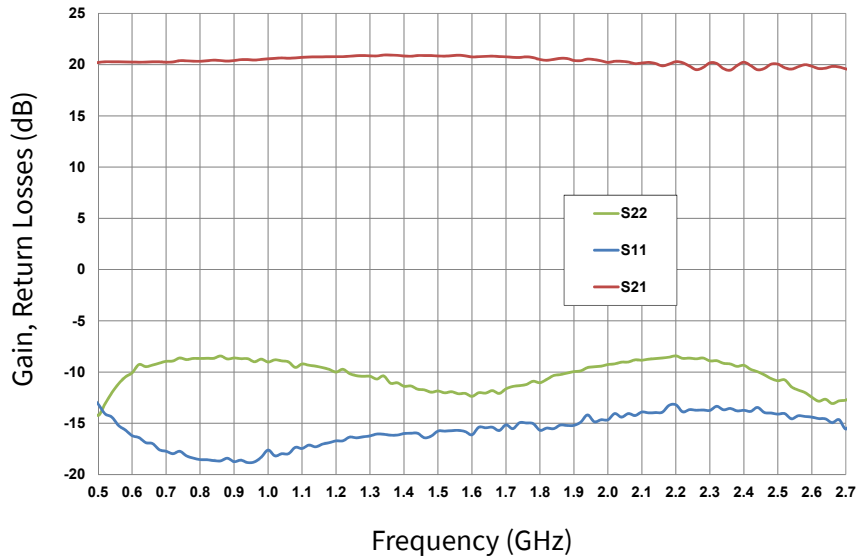
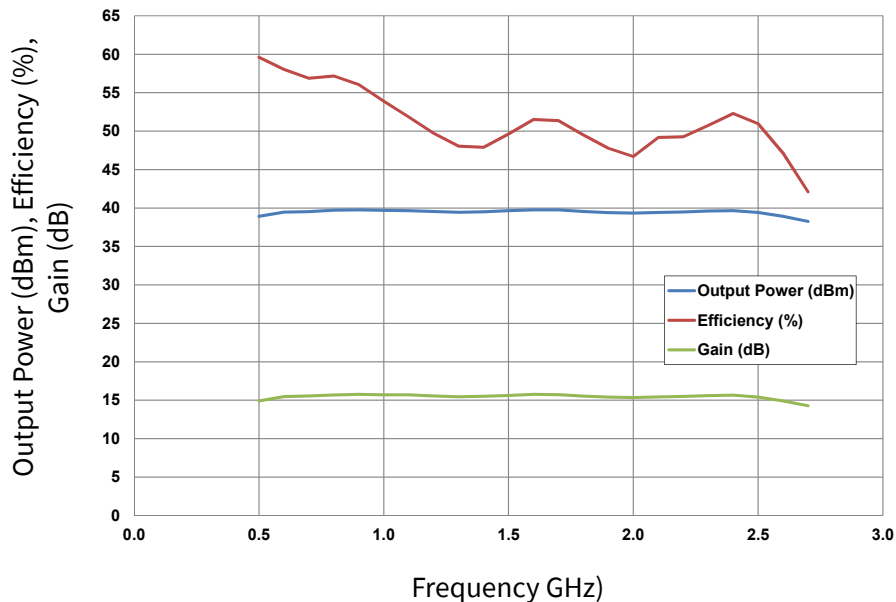

Figure 2. Output Power, Power Added Efficiency and Gain vs Frequency of the CMPA0527005F as measured in demonstration amplifier circuit CMPA0527005F-AMP1
 $V_{DD} = 50\text{ V}, I_{DQ} = 0.110\text{ A}, P_{IN} = 24\text{ dBm CW}, T_{case} = 25^\circ\text{C}$





CMPA0527005F Typical Performance in CMPA0527005F-AMP1 Application Circuit

Figure 3. Gain (dB) and Efficiency (%) vs Output Power (dBm) of the CMPA0527005F as measured in demonstration amplifier circuit CMPA0527005F-AMP1
 $V_{DD} = 50\text{ V}$, $I_{DQ} = 0.110\text{ A}$, $T_{case} = 25^\circ\text{C}$

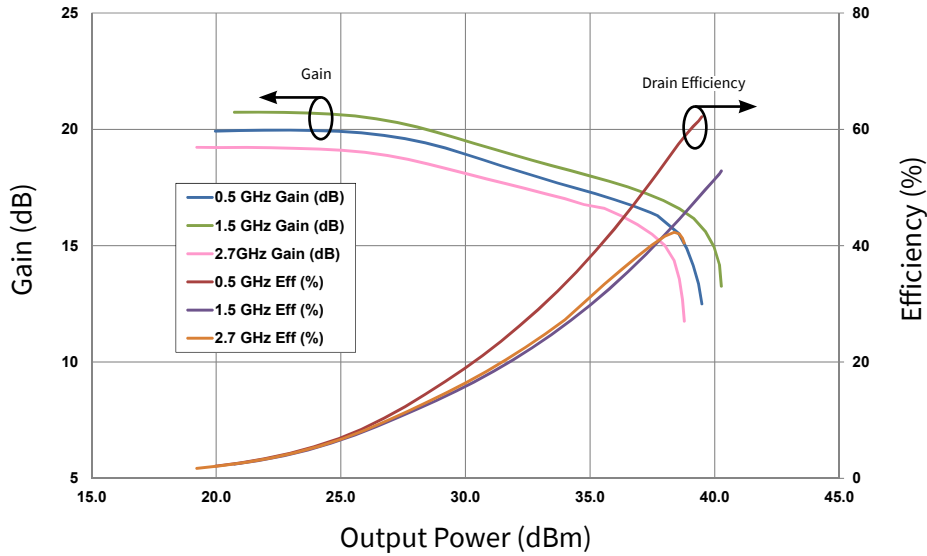
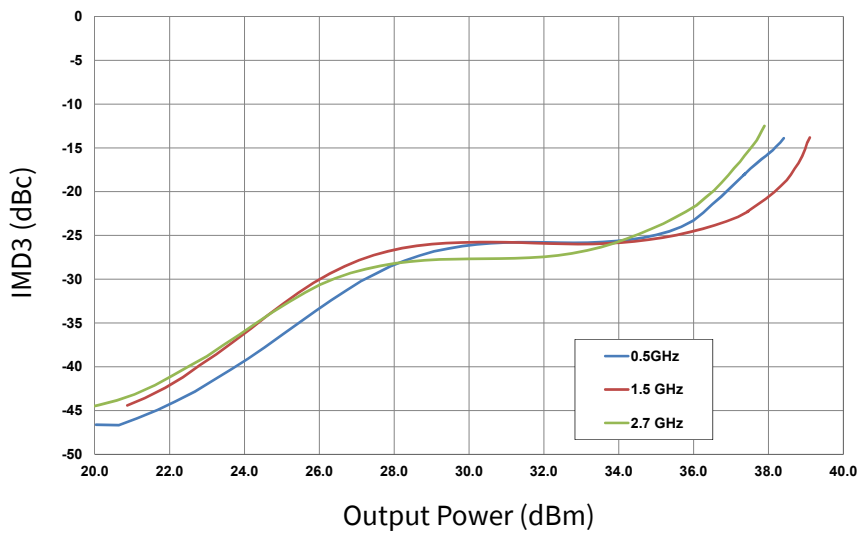

Figure 4. Third Order Intermodulation Distortion vs Output Power measured in demonstration amplifier circuit CMPA0527005F-AMP1
 $V_{DD} = 50\text{ V}$, $I_{DQ} = 0.110\text{ A}$, $T_{case} = 25^\circ\text{C}$, $\Delta f = 1\text{ MHz}$





CMPA0527005F Typical Performance

Figure 5. Simulated G_{MAX} and K-Factor vs Frequency
 $V_{DD} = 50\text{ V}$, $I_{DQ} = 0.110\text{ A}$, $T_{case} = 25^\circ\text{C}$

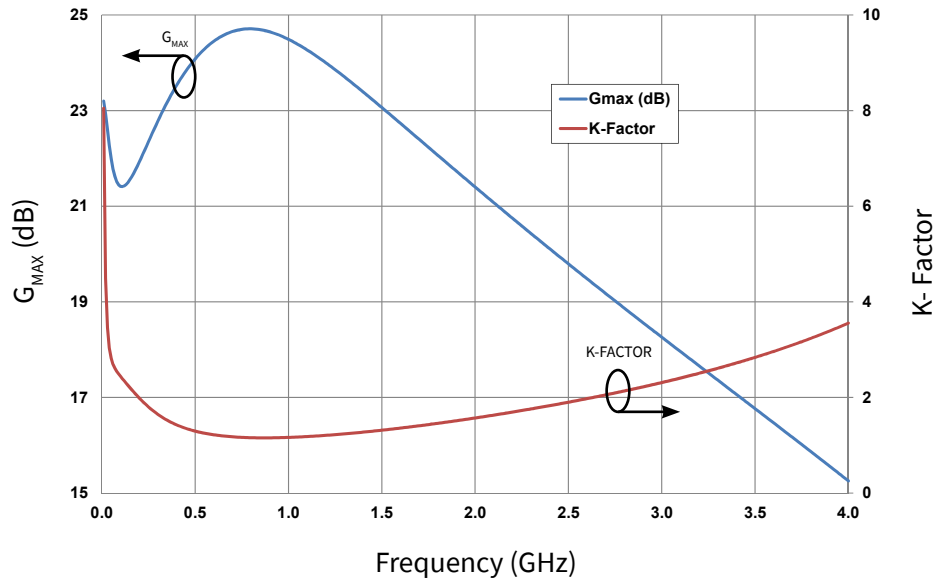

CMPA0527005F Power Dissipation De-rating Curve

Figure 6. Transient Power Dissipation De-Rating Curve

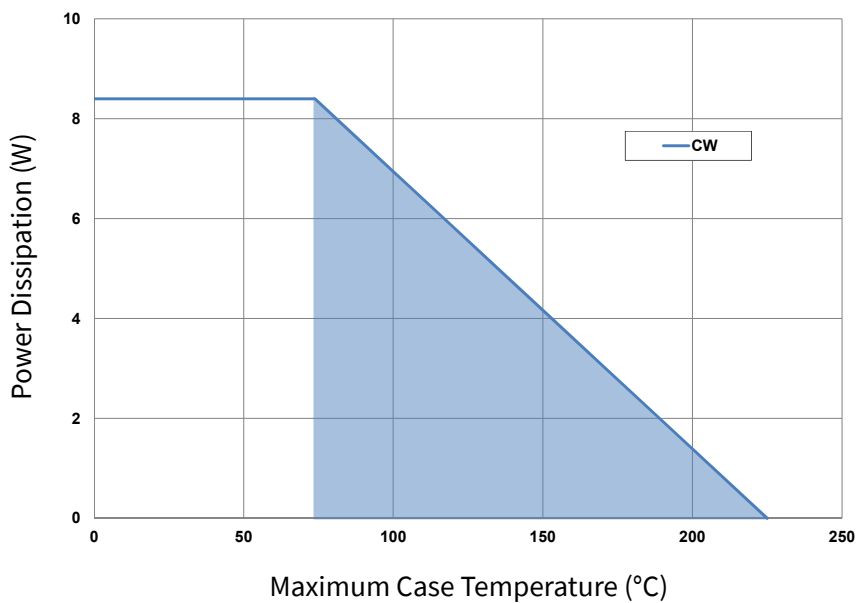

Note: Shaded area exceeds Maximum Case Temperature (See Page 2).



Source and Load Impedances

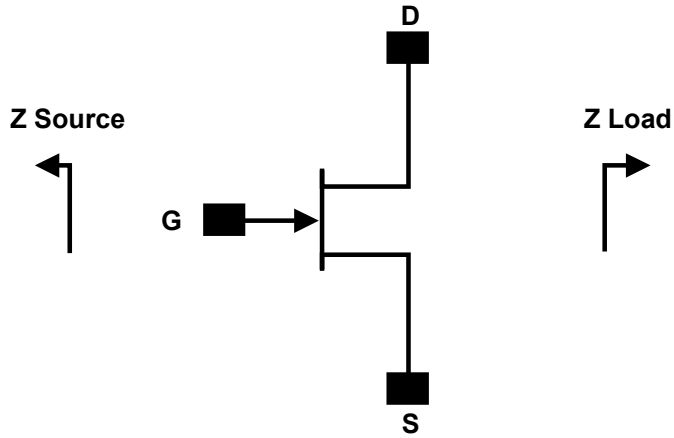

Frequency (GHz)	Z Load
0.5	143+j115
1	63.18+j93.20
1.5	39.49+j67.24
2	40.13+j42.78
2.3	40.19+j42.82
2.7	30.48+j29.17

Note 1. $V_{DD} = 50\text{ V}$, $I_{DQ} = 0.110\text{ A}$ in the 440221 package
 Note 2. Optimized for power gain, P_{SAT} and PAE

Electrostatic Discharge (ESD) Classifications

Parameter	Symbol	Class	Test Methodology
Human Body Model	HBM	1A (> 250 V)	JEDEC JESD22 A114-D
Charge Device Model	CDM	2 (125 V to 250 V)	JEDEC JESD22 C101-C



CMPA0527005F-AMP1 Application Circuit Schematic

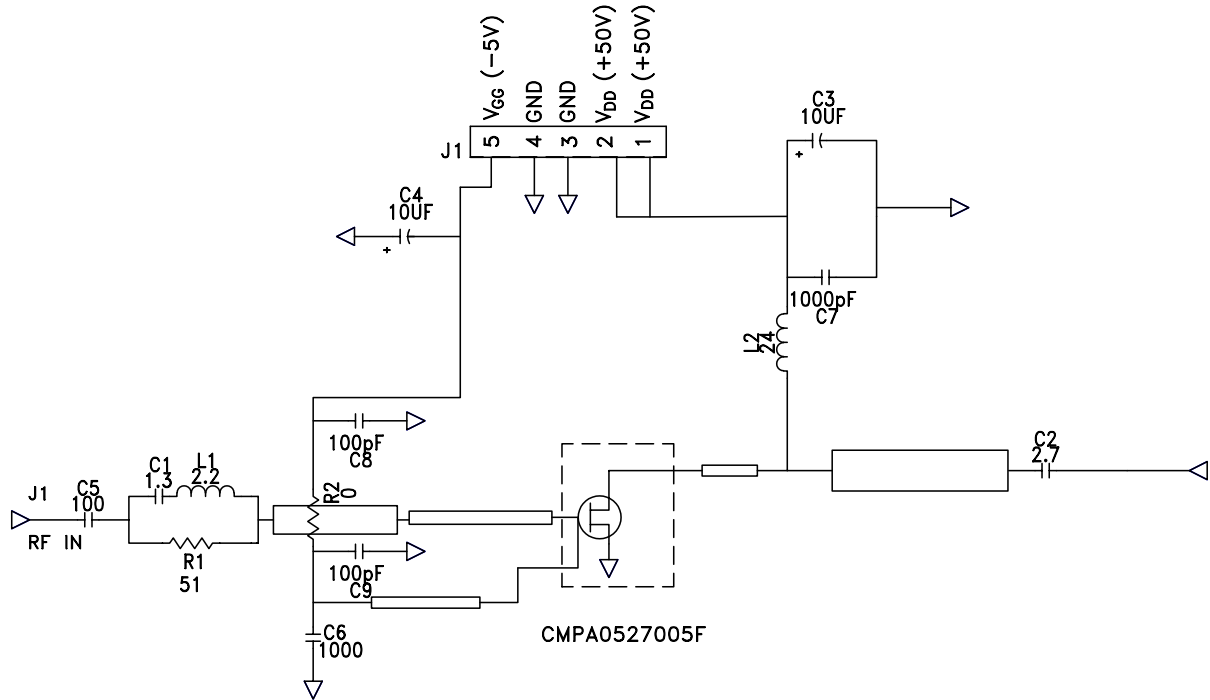

CMPA0527005F-AMP1 Application Circuit

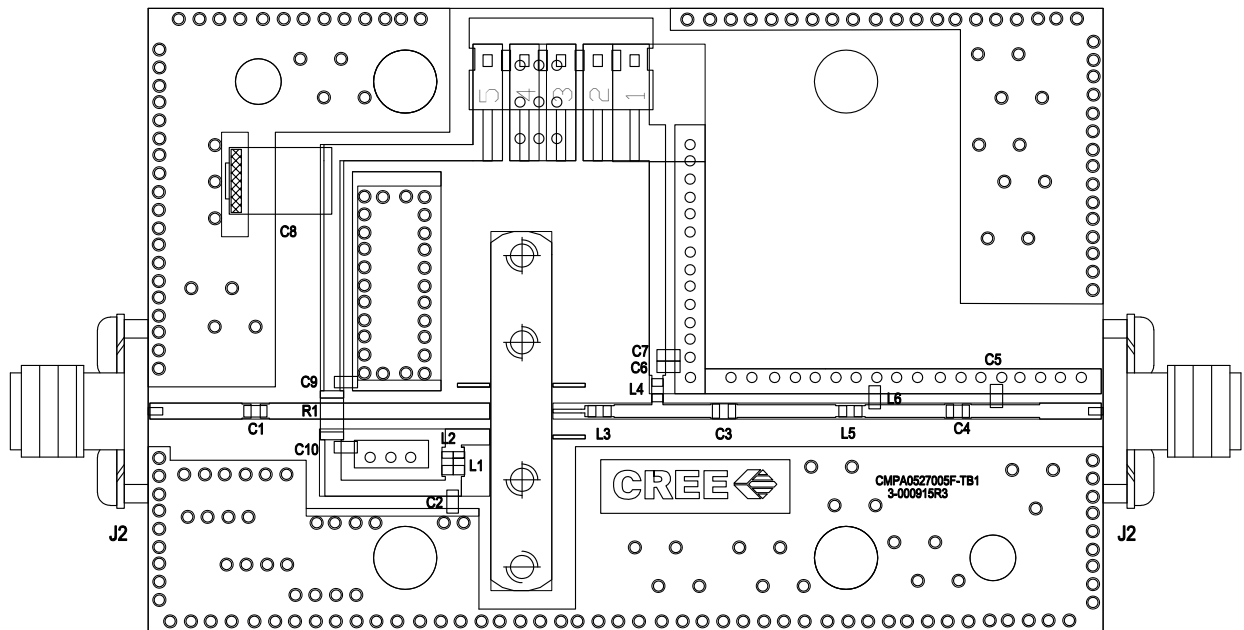



CMPA0527005F-AMP1 Application Circuit Bill of Materials

Designator	Description	Qty
C1	CAP, 33PF, 5%, 0603, ATC	1
C2, C6, C9	CAP, 100PF, 5%, 0603, ATC	3
C3	CAP, 3PF, 5%, 0805, ATC	1
C4	CAP, 12PF, 5%, 0603, ATC	1
C5	CAP, 0.3pF, 5%, 0603, ATC	1
C7	CAP, 470pF, 5%, 0603,100V. X7R	1
C8	CAP, 33000pF, 0805,100V,X7R	1
R1	RES, 1/16W, 1206, 1%, 0 Ohms	1
L1,L2,L5	INDUCTOR,CHIP,1.6nH,0603CS SMT	3
L3	INDUCTOR,CHIP,4.3nH,0603CS SMT	1
L4	INDUCTOR,CHIP,15nH,0603HP SMT	1
L6	INDUCTOR,CHIP,12nH,0603CS SMT	1
Q1	Transistor CMPA0527005F	1
	PCB, RO4350, CMPA0527005F Applications Board, 1.7" X 2.6"X0.02"	1
	BASEPLATE, AL, 2.60 X 1.7 X 0.25	1
	2-56 SOC HD SCREW 1/4 SS	4
	#2 SPLIT LOCKWASHER SS	4
J1,J2	CONN, SMA, PANEL MOUNT JACK, FLANGE, 4-HOLE, BLUNT POST, 20MIL	2
J3	HEADER RT>PLZ .1CEN LK 5POS	1

CMPA0527005F-AMP1 Demonstration Amplifier Circuit

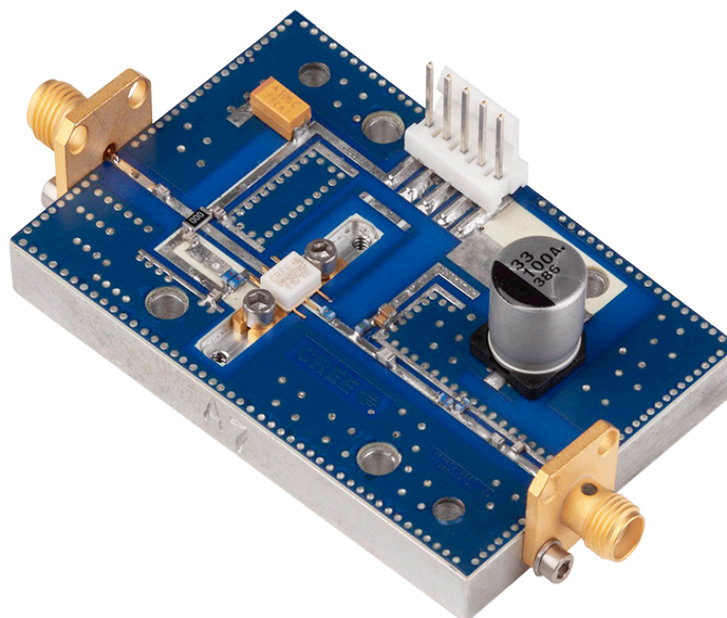



Product Dimensions CMPA0527005F (Package Type – 440221)

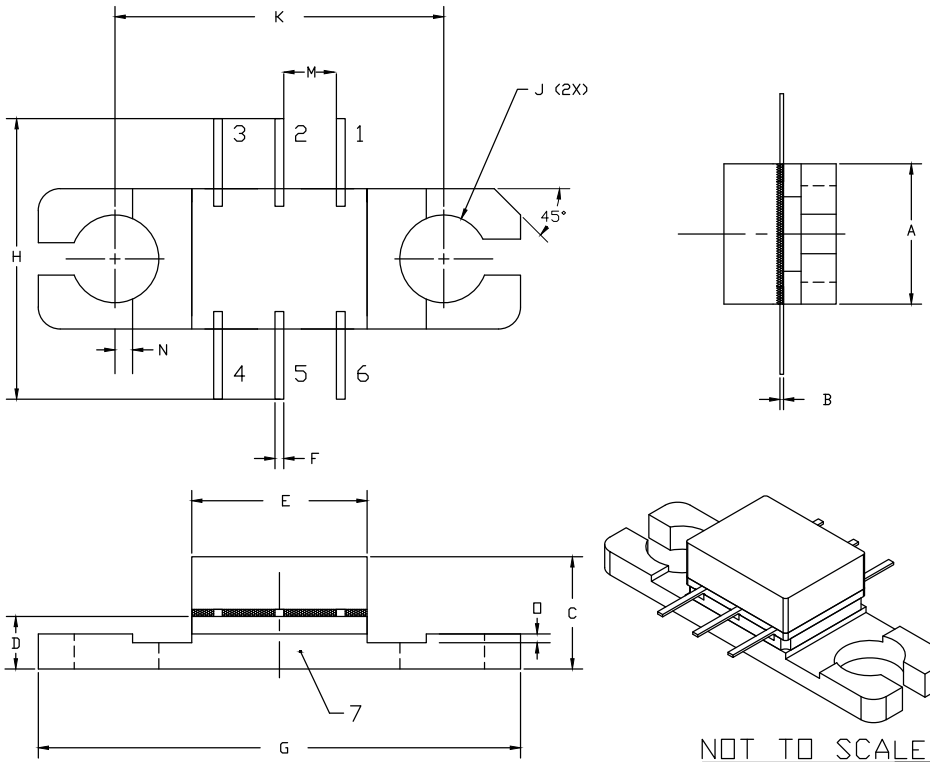

NOTES:

1. DIMENSIONING AND TOLERANCING PER ANSI Y14.5M, 1982.
2. CONTROLLING DIMENSION: INCH.
3. ADHESIVE FROM LID MAY EXTEND A MAXIMUM OF 0.020" BEYOND EDGE OF LID.
4. LID MAY BE MISALIGNED TO THE BODY OF THE PACKAGE BY A MAXIMUM OF 0.008" IN ANY DIRECTION.
5. ALL PLATED SURFACES ARE NI/AU

DIM	INCHES		MILLIMETERS	
	MIN	MAX	MIN	MAX
A	0.155	0.165	3.94	4.19
B	0.003	0.005	0.076	0.127
C	0.118	0.138	3.00	3.50
D	0.055	0.065	1.40	1.65
E	0.195	0.205	4.95	5.21
F	0.009	0.011	0.23	0.28
G	0.545	0.555	13.84	14.09
H	0.280	0.360	7.11	9.14
J	Ø .100		2.54	
K	0.375		9.53	
M	0.061		1.54	
N	0.018	0.022	0.46	0.56
O	0.008	0.012	0.20	0.30

Pin Number	Qty
1	Gate Bias
2	RF _{IN}
3	NC
4	NC
5	RF _{OUT} + Drain Bias
6	NC
7	Source



Part Number System

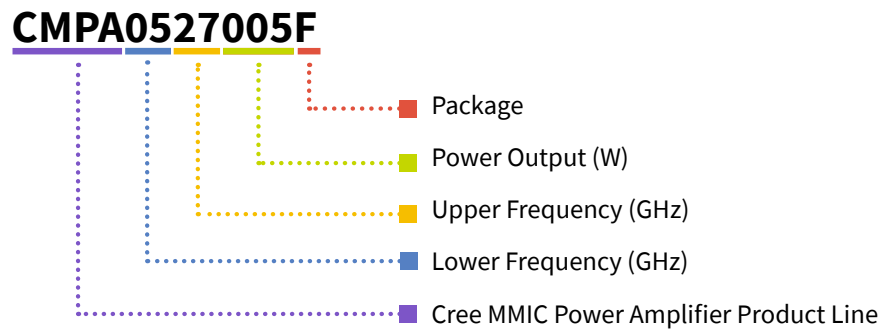

Table 1.

Parameter	Value	Units
Upper Frequency ¹	2.7	GHz
Power Output	5	W
Package	Flange	-

Note¹: Alpha characters used in frequency code indicate a value greater than 9.9 GHz. See Table 2 for value.

Table 2.

Character Code	Code Value
A	0
B	1
C	2
D	3
E	4
F	5
G	6
H	7
J	8
K	9
Examples:	1A = 10.0 GHz 2H = 27.0 GHz



Product Ordering Information

Order Number	Description	Unit of Measure	Image
CMPA0527005F	GaN HEMT	Each	
CMPA0527005F-AMP1	Test board with GaN HEMT (flanged) installed	Each	



For more information, please contact:

4600 Silicon Drive
Durham, North Carolina, USA 27703
www.wolfspeed.com/RF

Sales Contact
RFSales@wolfspeed.com

RF Product Marketing Contact
RFMarketing@wolfspeed.com

Notes

Disclaimer

Specifications are subject to change without notice. Cree, Inc. believes the information contained within this data sheet to be accurate and reliable. However, no responsibility is assumed by Cree for any infringement of patents or other rights of third parties which may result from its use. No license is granted by implication or otherwise under any patent or patent rights of Cree. Cree makes no warranty, representation or guarantee regarding the suitability of its products for any particular purpose. “Typical” parameters are the average values expected by Cree in large quantities and are provided for information purposes only. These values can and do vary in different applications and actual performance can vary over time. All operating parameters should be validated by customer’s technical experts for each application. Cree products are not designed, intended or authorized for use as components in applications intended for surgical implant into the body or to support or sustain life, in applications in which the failure of the Cree product could result in personal injury or death or in applications for planning, construction, maintenance or direct operation of a nuclear facility.