

### Features

- ▶ Ultra low noise figure
- ▶ Low current consumption
- ▶ High gain broadband performance
- ▶ Single positive supply voltage
- ▶ Pb-free RoHs compliant 3x3 QFN package

### Description

The CMD318P3 is a broadband MMIC low noise amplifier housed in a leadless 3x3 mm plastic surface mount package. The CMD318P3 is ideally suited for microwave radios and C and X-band applications where small size and low power consumption are needed. The broadband device delivers 22 dB of gain with a corresponding output 1 dB compression point of +14 dBm and a noise figure of 1.25 dB at 8 GHz. The CMD318P3 is a 50 ohm matched design eliminating the need for external DC blocks and RF port matching.

### Functional Block Diagram

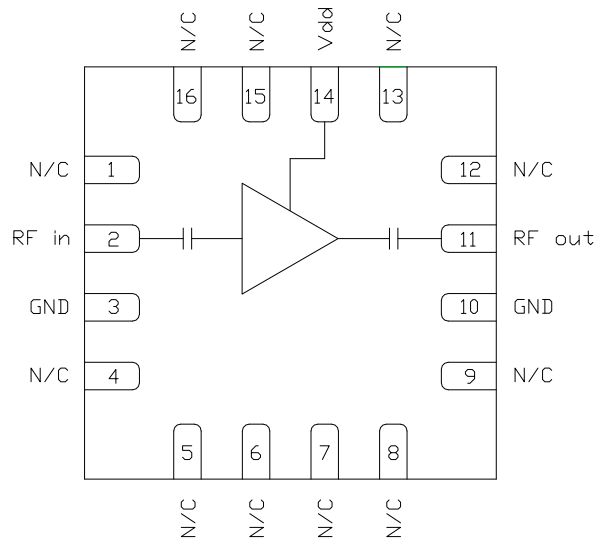

### Electrical Performance - $V_{dd} = 3.6\text{ V}$ , $T_A = 25\text{ }^\circ\text{C}$ , $F=8\text{GHz}$

Parameter	Min	Typ	Max	Units
Frequency Range		5 - 9		GHz
Gain		22		dB
Noise Figure		1.25		dB
Input Return Loss		11		dB
Output Return Loss		25		dB
Output P1dB		14		dBm
Output IP3		25.5		dBm
Supply Current		33		mA

ver A 1119

### Specifications

#### Absolute Maximum Ratings

Parameter	Rating
Drain Voltage, Vdd	5.0 V
RF Input Power	+20 dBm
Channel Temperature, Tch	150 °C
Power Dissipation, Pdiss	390 mW
Thermal Resistance, $\Theta_{JC}$	165 °C/W
Operating Temperature	-40 to 85 °C
Storage Temperature	-55 to 150 °C

Exceeding any one or combination of the maximum ratings may cause permanent damage to the device.

#### Recommended Operating Conditions

Parameter	Min	Typ	Max	Units
Vdd	2.5	3.6	4.5	V
Idd		33		mA

Electrical performance is measured at specific test conditions. Electrical specifications are not guaranteed over all recommended operating conditions.

#### Drain Current vs. Drain Voltage

Vdd (V)	Idd (mA)
2.5	22
3.6	33
4.5	42

#### Electrical Specifications - V<sub>dd</sub> = 3.6 V, T<sub>A</sub> = 25 °C

Parameter	Min	Typ	Max	Min	Typ	Max	Units
Frequency Range	5 - 9			7.2 - 8.4			GHz
Gain	18	22.5		18.5	22		dB
Noise Figure		1.25	2		1.25	1.7	dB
Input Return Loss		11			12		dB
Output Return Loss		18			25		dB
Output P1dB		13			14		dBm
Output IP3		25			25.5		dBm
Supply Current	23	33	43	23	33	43	mA
Gain Temperature Coefficient		0.016			0.016		dB/°C
Noise Figure Temperature Coefficient		0.006			0.006		dB/°C

ver A 1119

### Typical Performance

**Broadband Performance,  $V_{dd} = 3.6\text{ V}$ ,  $T_A = 25\text{ }^\circ\text{C}$**

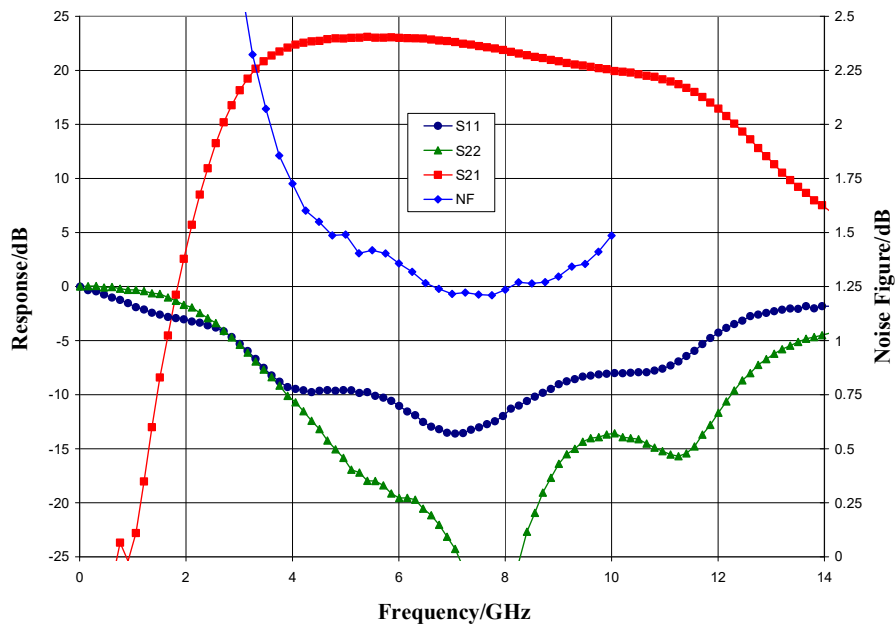

**Narrow-band Performance,  $V_{dd} = 3.6\text{ V}$ ,  $T_A = 25\text{ }^\circ\text{C}$**

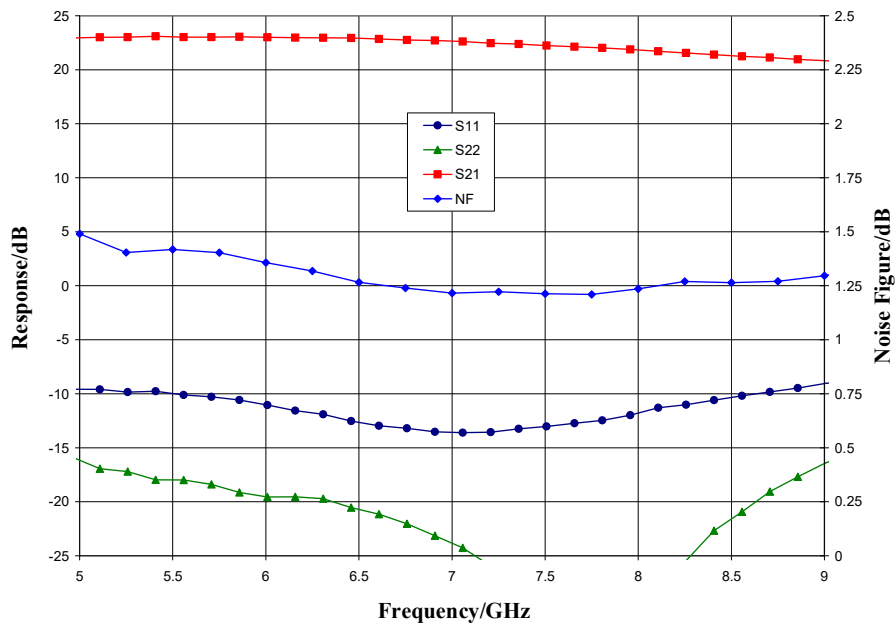

ver A 1119

### Typical Performance

Gain vs. Temperature,  $V_{dd} = 3.6\text{ V}$

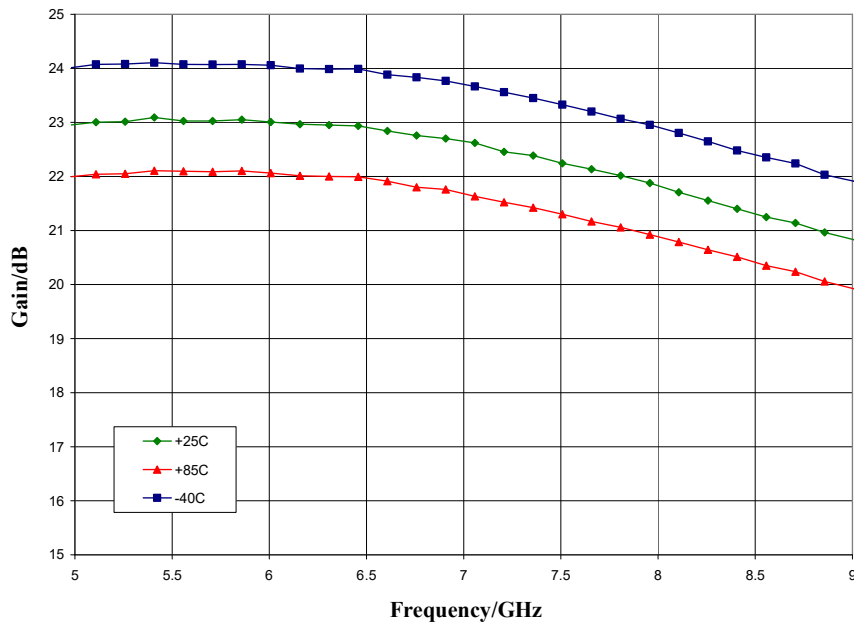

Gain vs.  $V_{dd}$ ,  $T_A = 25\text{ }^\circ\text{C}$

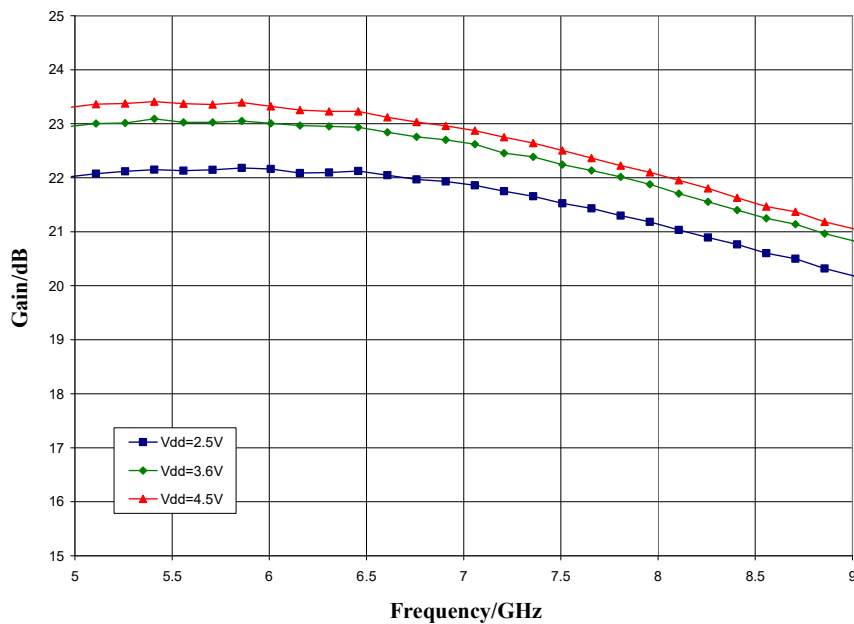

### Typical Performance

Noise Figure vs. Temperature,  $V_{dd} = 3.6\text{ V}$

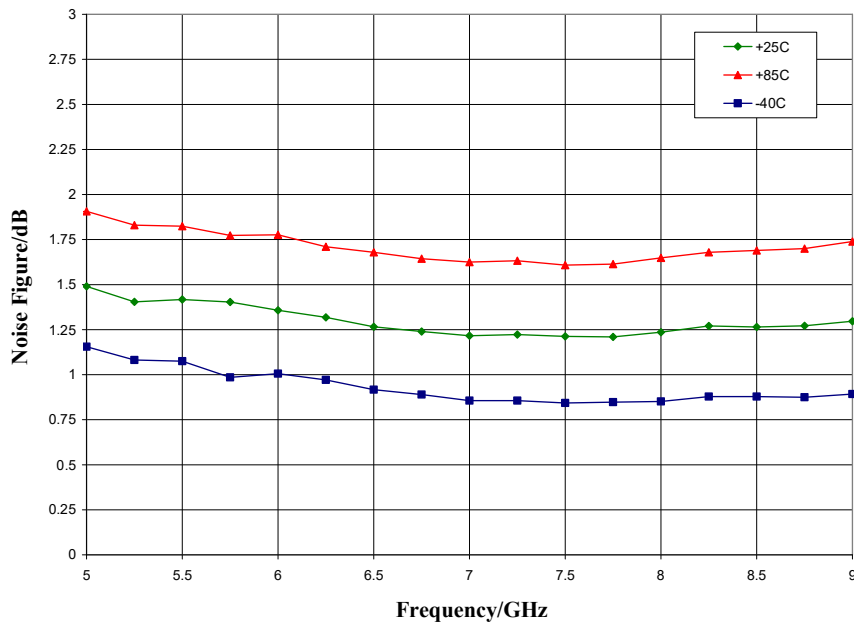

Noise Figure vs.  $V_{dd}$ ,  $T_A = 25\text{ }^\circ\text{C}$

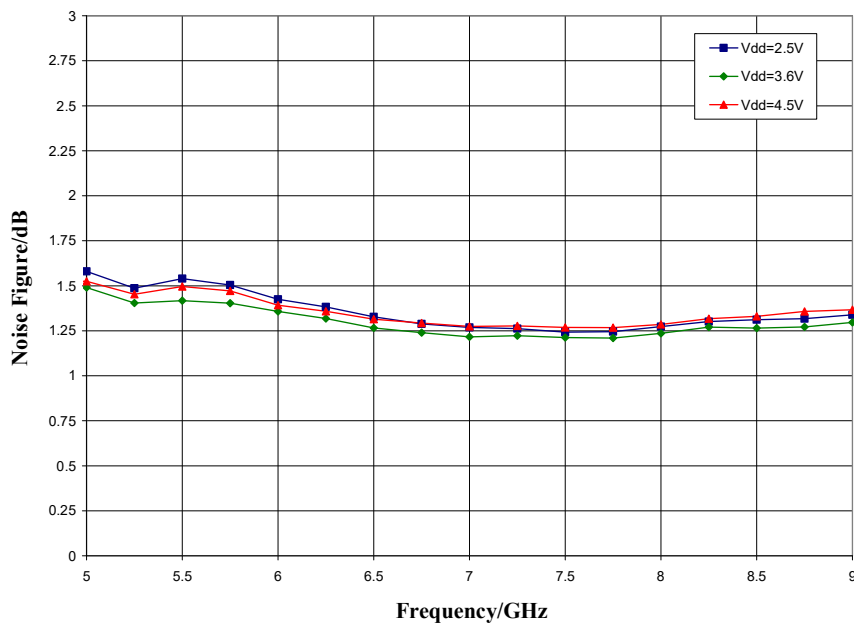

### Typical Performance

**P1dB vs. Temperature,  $V_{dd} = 3.6\text{ V}$**

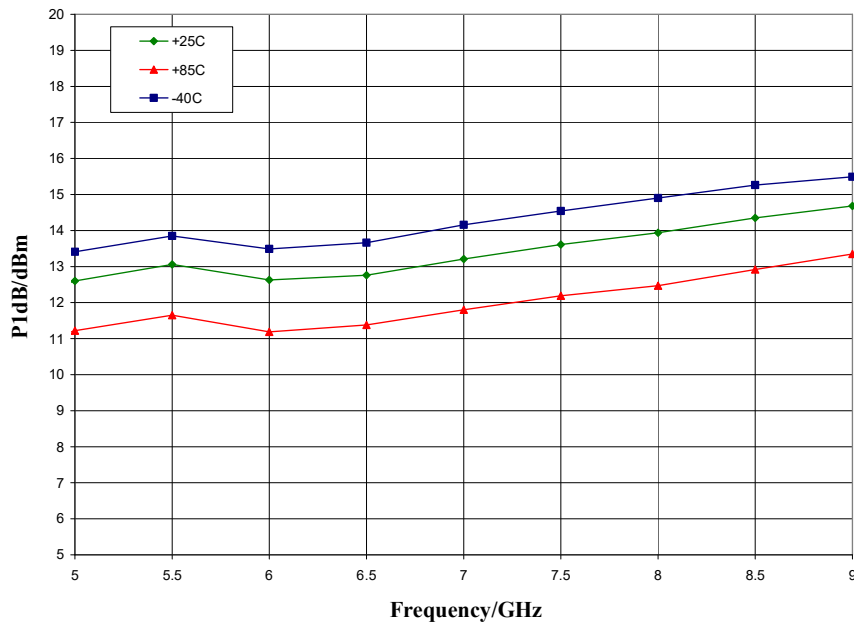

**P1dB vs.  $V_{dd}$ ,  $T_A = 25\text{ }^\circ\text{C}$**

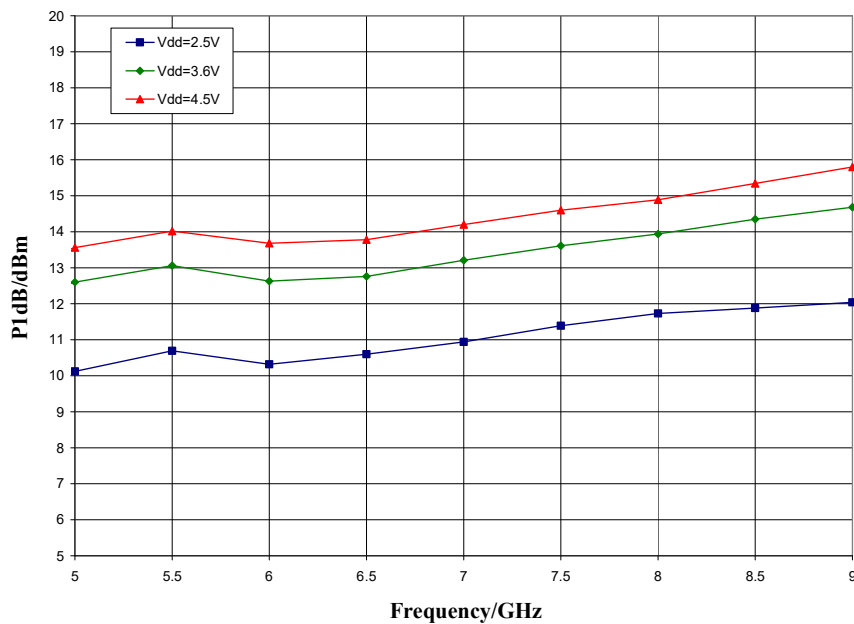

ver A 1119

### Typical Performance

**Psat vs. Temperature,  $V_{dd} = 3.6\text{ V}$**

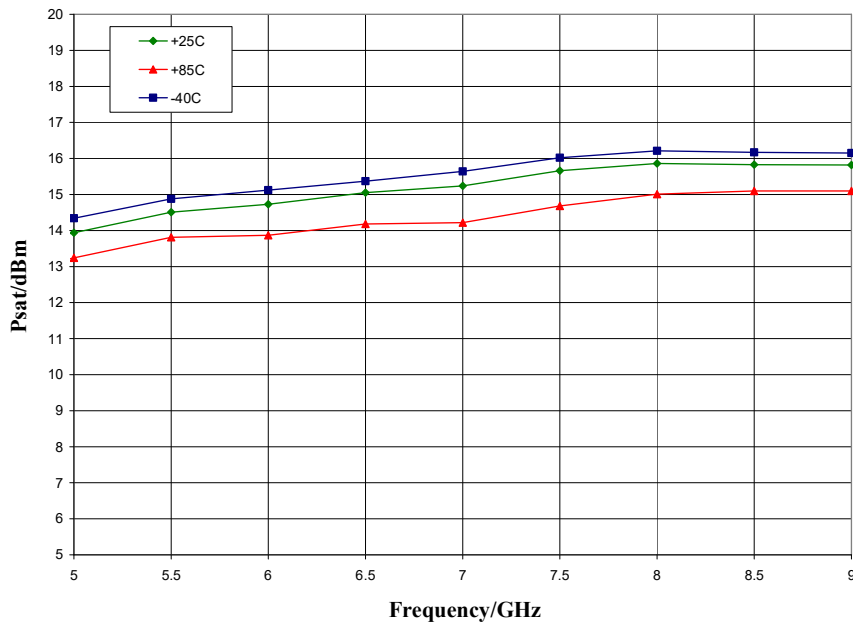

**Psat vs.  $V_{dd}$ ,  $T_A = 25\text{ }^\circ\text{C}$**

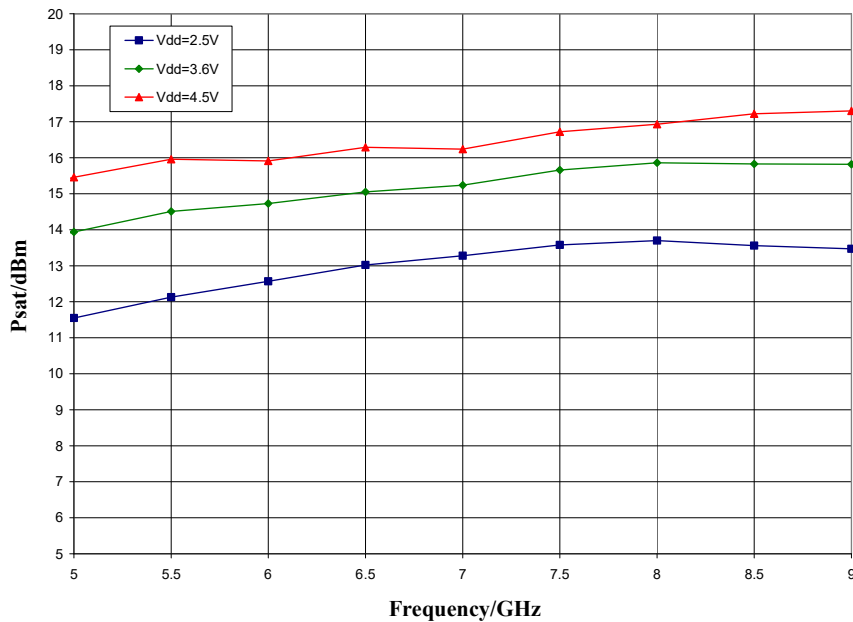

### Typical Performance

Output IP3 vs. Temperature,  $V_{dd} = 3.6\text{ V}$

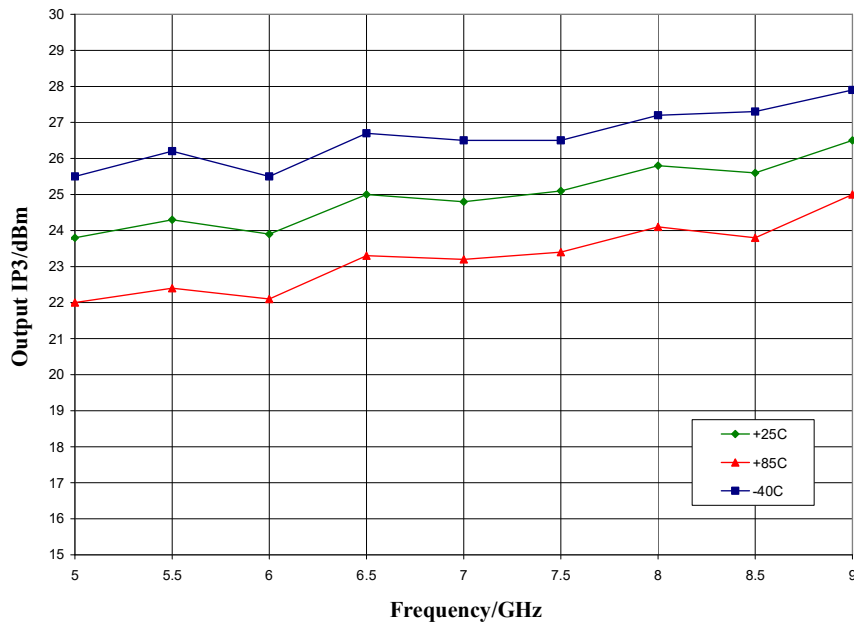

Output IP3 vs.  $V_{dd}$ ,  $T_A = 25\text{ }^\circ\text{C}$

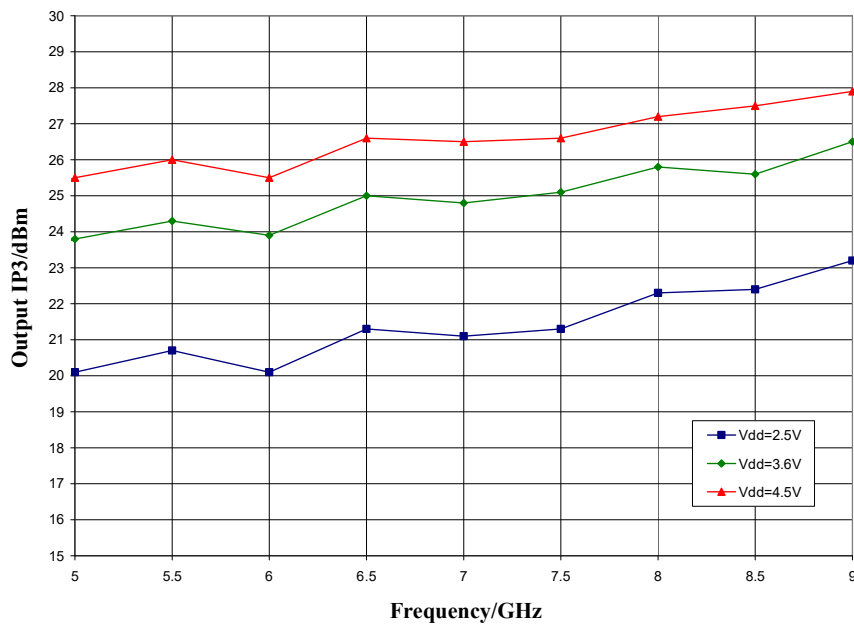

ver A 1119

### Mechanical Information

#### Package Information and Dimensions

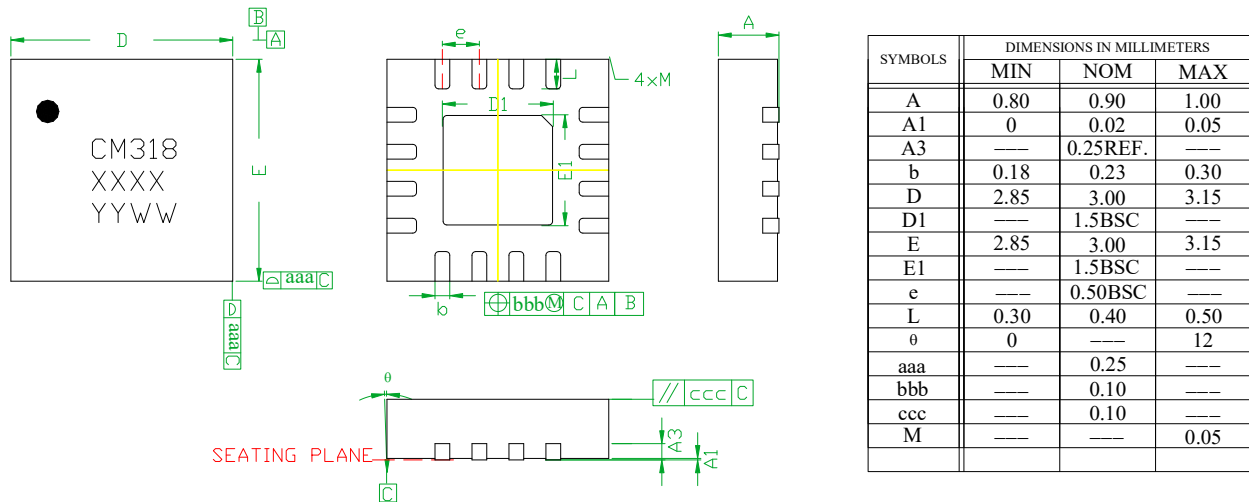

**NOTES:**

1. DIMENSIONS ARE IN MILLIMETERS
2. RoHS COMPLIANT MOLD COMPOUND
3. LEADFRAME MATERIAL: COPPER ALLOY
4. LEAD FINISH: ELECTROLESS NICKEL ELECTROLESS PALLADIUM IMMERSION GOLD (ENEPIG) PLATING IN ACCORDANCE WITH IPC-4556
5. INDICATED DIMENSION/TOLERANCE APPLIES TO LEADS AND EXPOSED PAD

#### Recommended PCB Land Pattern

Custom MMIC recommends that the user develop the land pattern that will provide the best design for proper solder reflow and device attach for their specific application. Please review Custom MMIC Application Note AN 105 for a recommended land pattern approach.

#### Recommended Solder Reflow Profile



Custom MMIC recommends screen printing with belt furnace reflow to ensure proper solder reflow and device attach. Please review Custom MMIC Application Note AN 102 for a recommended solder reflow profile.

### Pin Description

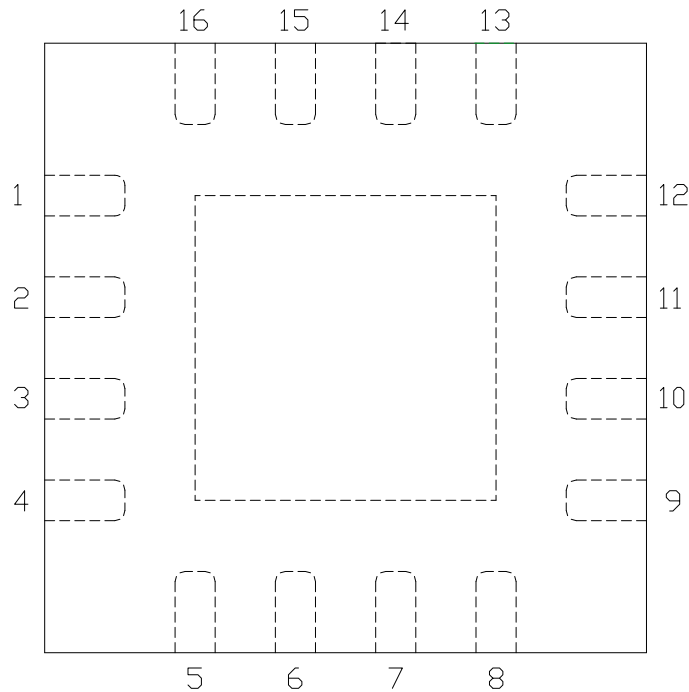
#### Pin Diagram

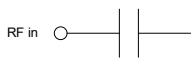

#### Functional Description

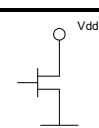
Pin	Function	Description	Schematic
1, 4-9, 12, 13, 15, 16	N/C	No connection required. These pins may be connected to RF/DC ground	
2	RF in	DC blocked and 50 ohm matched	
3, 10, and die paddle	Ground	Connect to RF / DC ground	
11	RF out	DC blocked and 50 ohm matched	
14	Vdd	Power supply voltage Decoupling and bypass caps required	

ver A 1119

### Applications Information

#### Application Circuit

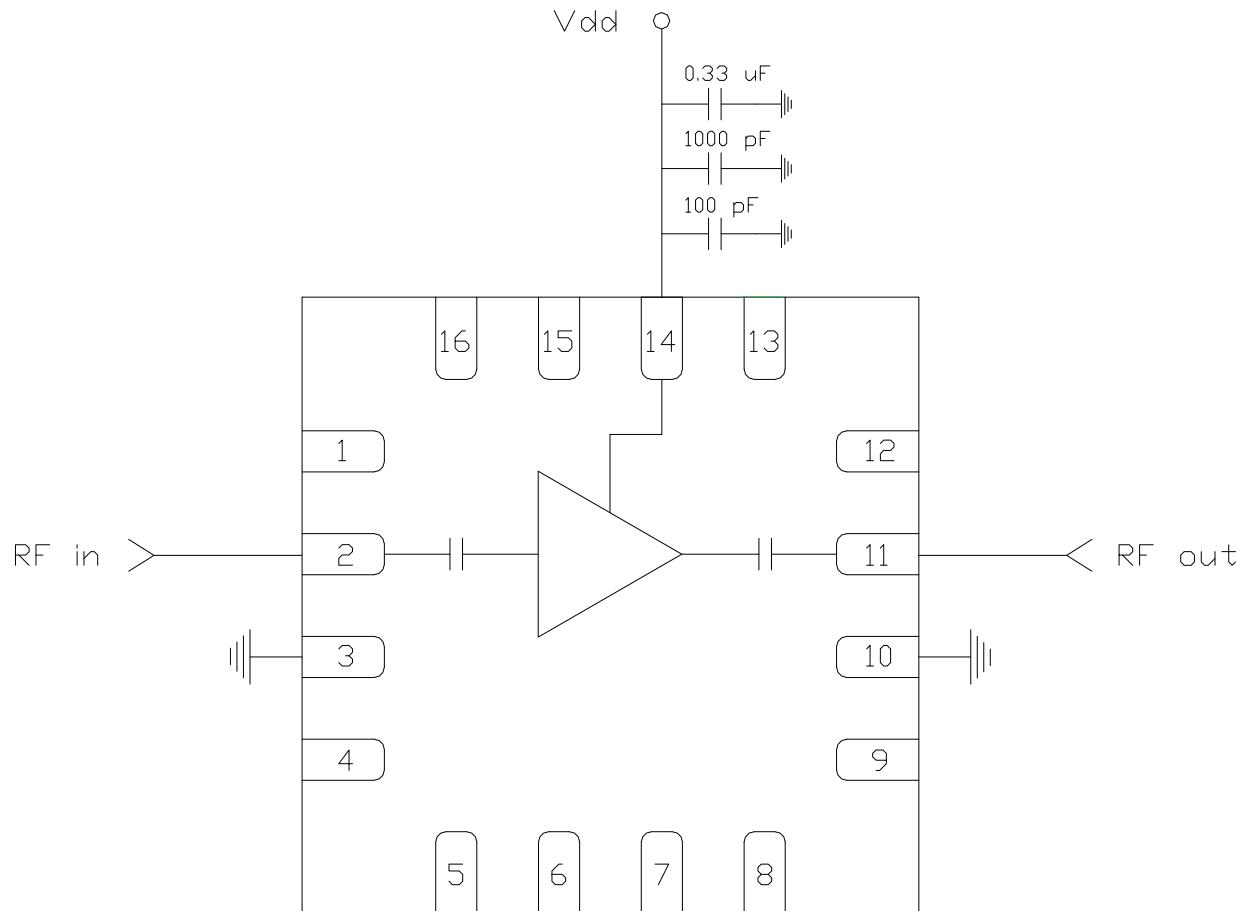

#### Biasing and Operation

The CMD318P3 is biased with a single 3.6 V positive drain supply.

RF power can be applied at any time.

**GaAs MMIC devices are susceptible to damage from Electrostatic Discharge. Proper precautions should be observed during handling, assembly and test.**

ver A 1119

### Applications Information

#### Evaluation Board

The circuit board shown has been developed for optimized assembly at Custom MMIC. A sufficient number of via holes should be used to connect the top and bottom ground planes. As surface mount processes vary, careful process development is recommended.

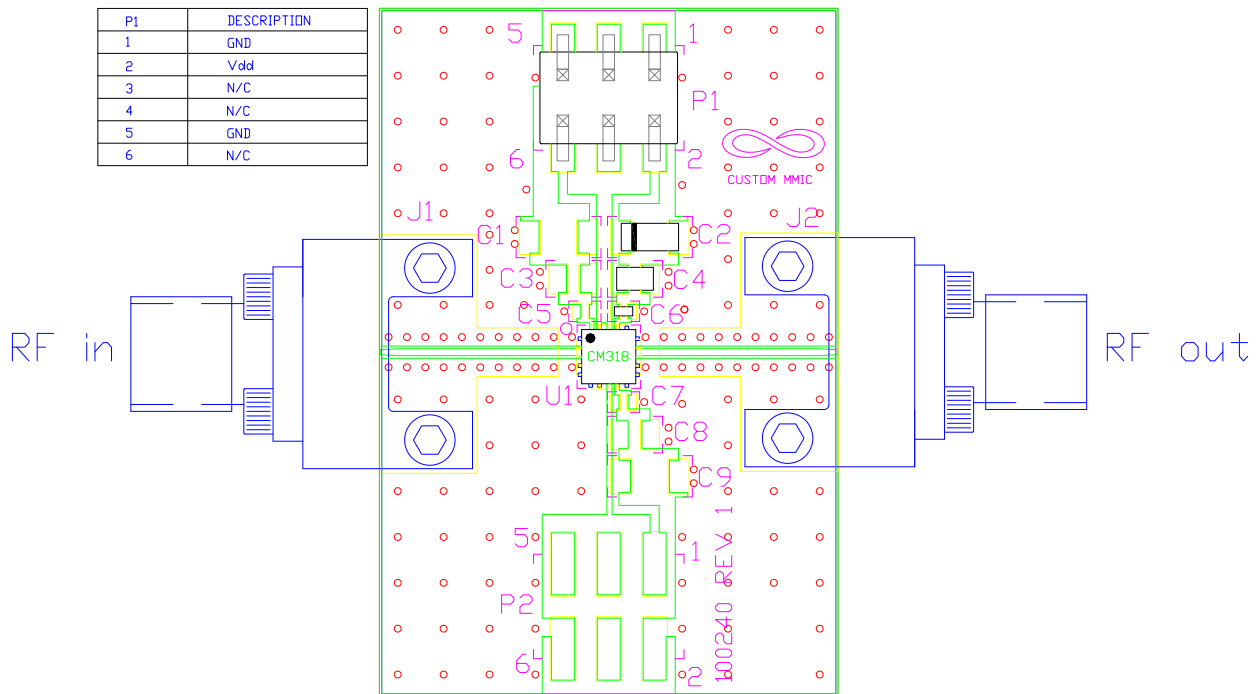

#### Bill of Material

Designator	Value	Description
J1, J2		SMA End Launch Connector
P1		6 Pin Header
C2	0.33 µF	Capacitor, Tantalum
C4	1000 pF	Capacitor, 0603
C6	100 pF	Capacitor, 0402
U1		CMD318P3 Low Noise Amplifier
PCB		100240 Evaluation PCB

Please note, all information contained in this data sheet are subject to change without notice.

ver A 1119