



# Installation Manual

# MA7200

## *AC Inverter*

<b>208 to 230V</b>	<b>1 / 3 Phase</b>	<b>1 ~ 3HP</b>
	<b>3 Phase</b>	<b>5 ~ 40HP</b>
<b>380 to 460V</b>	<b>3 Phase</b>	<b>1 ~ 75HP</b>

## ■ SAFE OPERATION NOTES

Read this instruction manual thoroughly before installation, operation, maintenance or inspection of the inverter. Only authorized personnel should be permitted to perform maintenance, inspections or parts replacement.

In this manual, notes for safe operation are classified as: “WARNING” or “CAUTION”.

 **WARNING** : Indicates a potentially hazardous situation that, if not avoided, could result in death or serious injury to personnel.

 **CAUTION** : Indicates a potentially hazardous situation that, if not avoided, may result in minor or moderate injury to personnel and damage to the equipment.

### ■ “WARNING” and “CAUTION”

 <b>WARNING</b>
<ul style="list-style-type: none"><li>• Always turn off the input power supply before wiring terminals.</li><li>• After turning OFF the main circuit power supply, do not touch the circuit components until the “CHARGE” LED is extinguished.</li><li>• Never connect power circuit output U/T1, V/T2, W/T3 to AC power supply.</li></ul>

 <b>CAUTION</b>
<ul style="list-style-type: none"><li>• When mounting the MA7200 in a separate enclosure, install a fan or other cooling device to keep the intake air temperature below 113°F (45°C).</li><li>• Do not perform a withstand voltage test to the inverter.</li><li>• All the parameters of the inverter have been preset at the factory. Do not change the settings unnecessarily.</li></ul>

This inverter has been placed through demanding tests at the factory before shipment. After unpacking, check for the following:

1. Verify that part numbers on shipping carton and unit match the purchase order sheet and/or packing list.
2. Do not install or operate any inverter that is damaged or missing parts.
3. Do not install or operate any inverter that has no QC marking.

Contact your local TECO authorized distributor or TECO representative if any of the above irregularities have been found.

<b>Contents</b>	<b>Page</b>
<b>1. MA7200 Handling Description -----</b>	<b>1-1</b>
1.1 Inspection Procedure upon Receiving -----	1-1
1.2 Installation -----	1-2
1.3 Removing/Attaching of LCD Digital Operator and Front Cover-----	1-4
1.4 Wiring between Inverter and Peripheral Devices-----	1-7
1.5 Description of Terminal Function -----	1-11
1.6 Main Circuit Wiring Diagram -----	1-13
1.7 Wiring Main Circuit-----	1-14
1.8 Inverter Specifications -----	1-17
1.9 Dimensions -----	1-19
1.10 Peripheral Units -----	1-22
1.11 FUSE TYPES -----	1-29
<b>2. Using LCD Digital Operator-----</b>	<b>2-1</b>
<b>3. Parameter Setting-----</b>	<b>3-1</b>
3.1 Frequency Command An-□□ -----	3-1
3.2 Parameters That Can be Changed during Running Bn-□□-----	3-2
3.3 Control Parameters Cn-□□ -----	3-12
3.4 System Parameters Sn-□□-----	3-30
3.5 Monitoring Parameters Un-□□-----	3-75
<b>4. Fault Display and Troubleshooting -----</b>	<b>4-1</b>
4.1 General -----	4-1
4.2 Error Message and Troubleshooting -----	4-2
<b>Appendix</b>	
A. PID Parameter Setting -----	App-1
B. Supplementary on PID Control Block Diagram -----	App-3
C. Wiring for PG Feedback Use-----	App-4
D. RS-485 Communication Interface-----	App-5
E. SINK/SOURCE Typical Connection Diagram -----	App-7
F. Set-up Using the Sensorless Vector Control -----	App-8
G. Notes for Circuit Protection and Environmental Ratings-----	App-10
H. Spare Parts-----	App-14
I. Electrical Ratings For Constant Torque and Quadratic Torque -----	App-24
J. Inverter Heat Loss -----	App-25

No.	Figure Contents	Page	No.	Figure Contents	Page
1	Air clearance for MA7200 wall mounting	1-2	27	S curve	3-27
2	Standard connection diagram	1-9	28	ASR Integral Gain 2	3-28
3	Processing the ends of twisted-pair cables	1-15	29	Deceleration to stop	3-44
4	The optical-couplers connect to external inductive load	1-15	30	Coast to Stop	3-44
5	MA7200 ground winding	1-16	31	Whole range DC Injecting Braking Stop	3-44
6	LCD digital operator dimension	1-27	32	Coast to Stop with Timer	3-45
7	Analog operator	1-28	33	Output voltage limit	3-48
8	LCD digital operator	2-1	34	Stall prevention function during deceleration	3-48
9	Acceleration and Deceleration time	3-4	35	Zero speed braking operation selection	3-49
10	Analog input gain and bias	3-5	36	Motor overload protection curve	3-51
11	Adjust the auto torque boost gain Bn-11 to increase the output torque	3-5	37	3-wire mode connection diagram	3-53
12	Block diagram for PID control in inverter	3-7	38	Operation sequence in 3-wire mode	3-53
13	Response of PID control for step-shape (deviation) input	3-8	39	2-wire mode connection diagram	3-53
14	PID Control Block diagram (After Version 30.18)	3-9	40	Time chart for multi-step speed and jog command	3-54
15	An operation example of timer function	3-9	41	Acceleration and deceleration ramp hold	3-55
16	Time chart for energy-saving operation	3-10	42	Time chart for DC injection braking command	3-57
17	User-defined V/F curve	3-15	43	PG speed control block diagram	3-58
18	Output frequency with slip compensation.	3-16	44	Time chart of output frequency with the UP/DOWN function	3-59
19	Slip compensation limit	3-16	45	Pulse signal output	3-65
20	DC injection braking time chart	3-17	46	The input/output signal in 'Timer' function application	3-66
21	Upper and lower bounds of the frequency command	3-18	47	PID control block diagram	App-3
22	Setting jump frequencies	3-18	48	PID wiring diagram	App-3
23	Acceleration stall prevention function	3-20	49	Wiring of PG feedback	App-4
24	Run stall prevention function	3-20	50	Wiring for MODBUS Protocol communication	App-5
25	Time chart for overtorque detection	3-23	51	Wiring for PROFIBUS protocol communication	App-6
26	Speed search timing chart	3-25	52	RS232-C Typical Connection Diagram	App-8

No.	Table Contents	Page
1	Main circuit terminals	1-11
2	Control circuit terminals	1-12
3	230V/460V class applicable wire size and connector	1-14
4	Brake resistor list	1-22
5	AC reactor list	1-23
6	Noise filter on the input side	1-24
7	Key's functions	2-2
8	Setting of monitoring contents	3-6
9	LCD Digital Operator Display Unit	3-21
10	230V Class Inverter Capacity Selection	3-39
11	460V Class Inverter Capacity Selection	3-40
12	V/F curve of 1~2 HP compact size, 230V Class MA inverter	3-41
13	V/F curve of 3~20 HP, 230V Class MA inverter	3-42
14	Multi-Function Input Setting	3-52
15	Multi-function analog input function list	3-60
16	Multi-function output terminal function	3-63

# 1. MA7200 Handling Description

## 1.1 Inspection Procedure upon Receiving

Before delivery, Every MA7200 inverter has been properly adjusted and passed the demanding function test. After receiving the inverter, the customer should take it out and follow the below procedure:

- Verify that the Type No. of the inverter you've received is the same as the Type No. listed on your purchase order. (Please read the Nameplate)
- Observe the condition of the shipping container and report any damage immediately to the commercial carrier that has delivered your inverter.

### ■ Inverter nameplate:

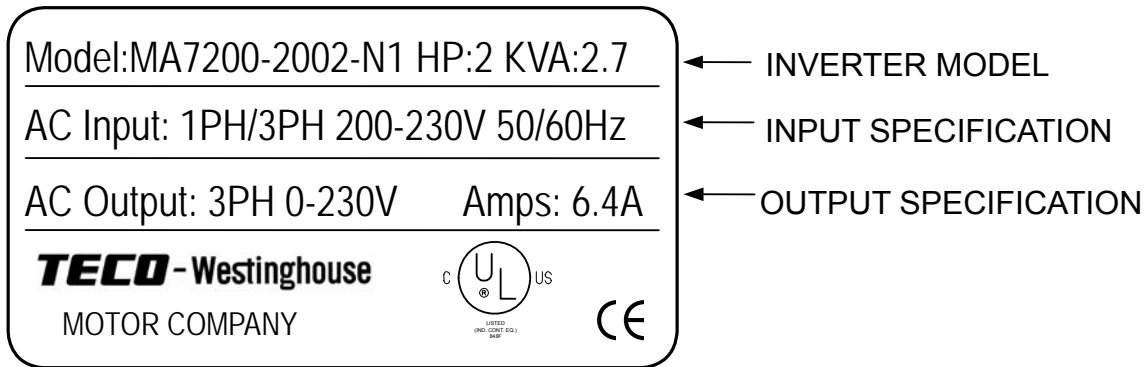

### ■ Inverter model number :

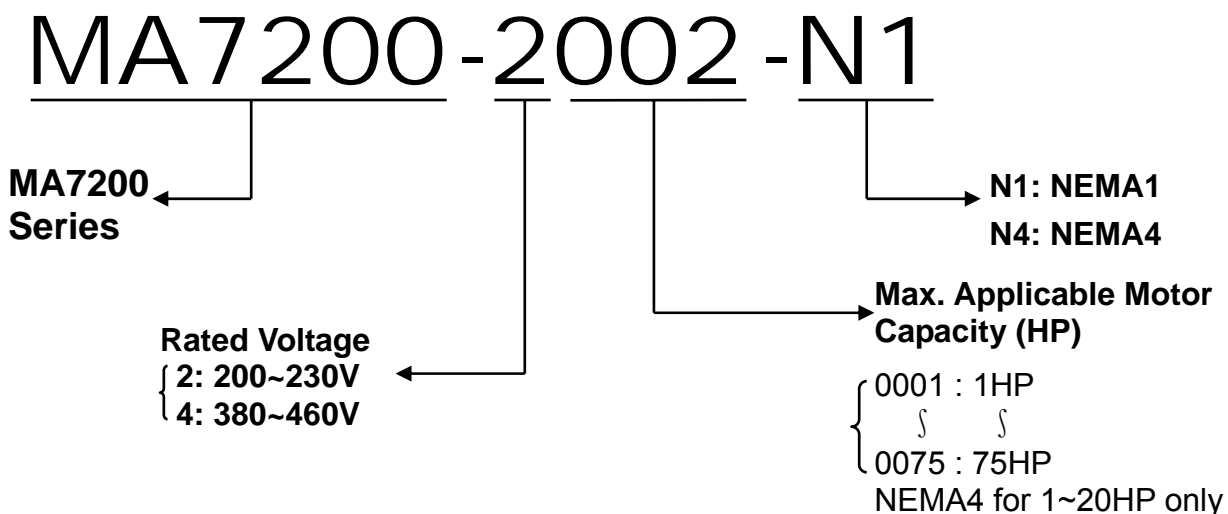

## 1.2 Installation

When installing the inverter, always provide the following space to allow normal heat dissipation.

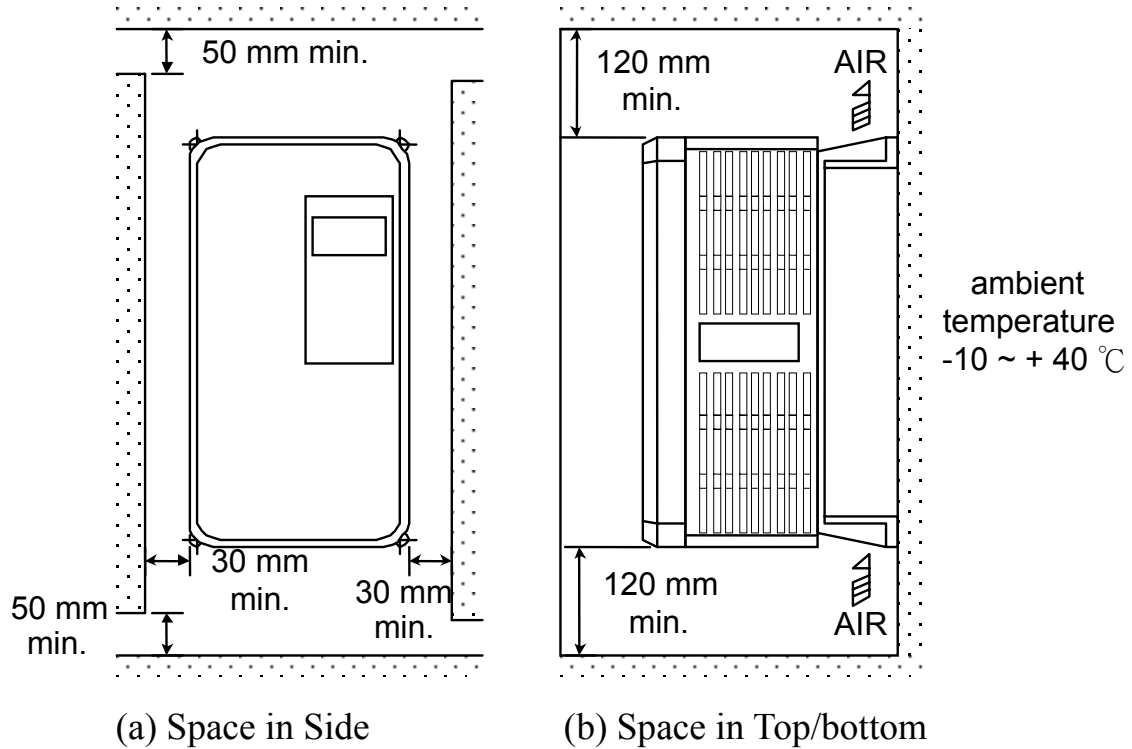

Fig. 1-a. Air clearance for MA7200 wall mounting

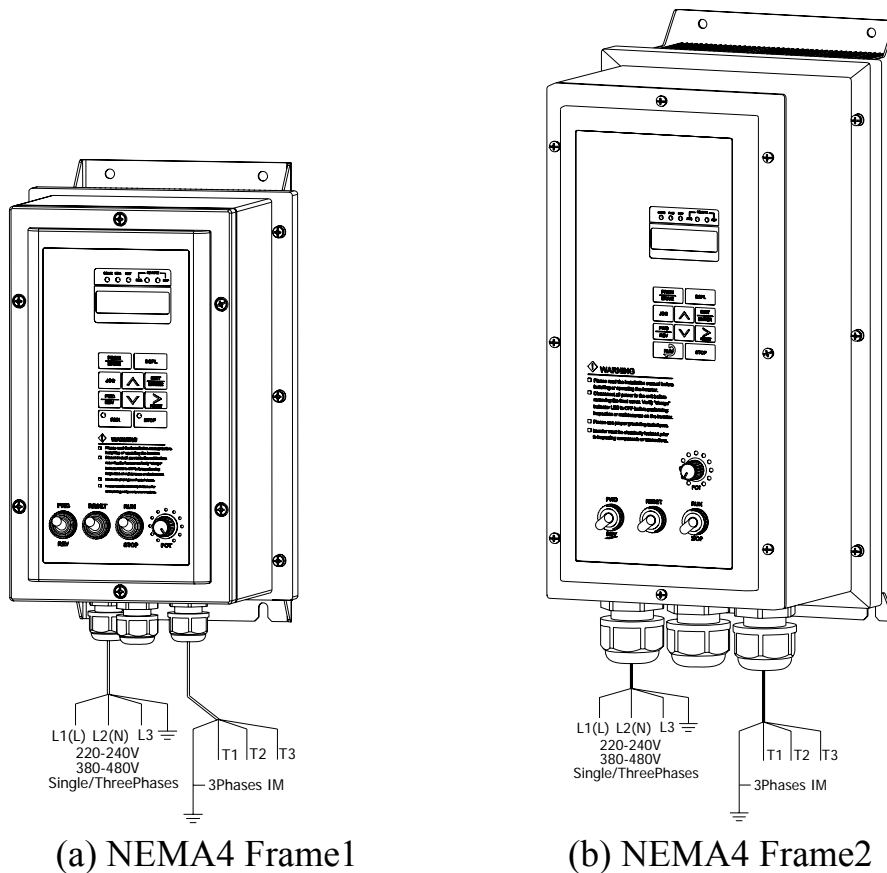

Fig. 1-b. MA7200 NEMA4 Installation



## CAUTION

Location of equipment is important to achieve proper performance and normal operating life. The MA7200 inverter should be installed in area where the following conditions exist.

- Ambient temperature: +14 to 104°F, (-10 to 40°C).
- Install the MA7200 in a location protected from rain, moisture and direct sunlight.
- Install the MA7200 in a location free from harmful mists, gases, liquids, airborne dusts and metallic particles.
- Install the MA7200 in a location free from vibration and electromagnetic noise. (i.e. welding machines, power units, etc...)
- When mounting multiple units in a common enclosure, install a cooling fan or some other means to cool the air entering the inverter to at least 113°F (+45°C) or below.

## 1.3 Removing/Attaching the Digital Operator and Front cover



### CAUTION

Please disassemble Front Cover before you connect wires to terminals on MA7200 models.

- 230V 1~25HP & 460V 1~30HP models: Plastic instructions, so please disconnect LCD Digital Operator before you disassemble Front Cover. After you finished the wiring connection, assemble Front Cover first then reinstall LCD Digital Operator.
- 230V 30HP、40HP & 460V 40~75HP: Iron instructions, you can disassemble Front Cover for wiring connection without disconnect LCD Digital Operator. Then reinstall Front Cover back after you finished wiring connection.

**MA7200 disassembly / Assembly procedures will be depended on different model as follows:**

(A) For 230V : 1-2HP, 460V : 1-2HP

- MA7200-2001-N1      • MA7200-4001-N1
- MA7200-2002-N1      • MA7200-4002-N1

#### ■ Removing the digital operator :

Take off the two screws on the front cover in the place a and b. Remove the front cover and take off the screws in the place c and d. Disconnect the RS-232 cable connector on the backside of the LCD digital operator. Lift and remove digital operator.

#### ■ Attaching the front cover and digital operator:

Connect the RS-232 cable connector on the back of the LCD digital operator.

Attach the digital operator and tighten the screws in the place c and d. Insert the tabs of the upper part of front cover into the groove of the inverter and tighten the screws in the place a and b.

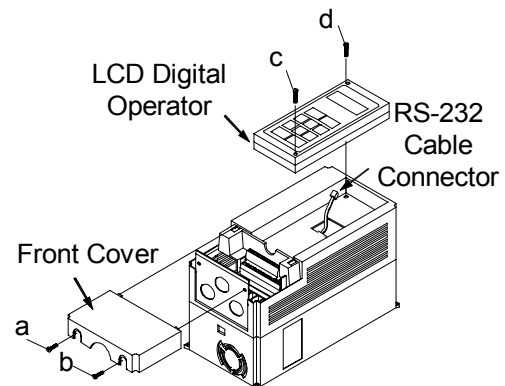

(B) For 230V : 3-10HP, 460V : 3-10HP

- MA7200-2003-N1
- MA7200-2005-N1
- MA7200-2007-N1
- MA7200-2010-N1
- MA7200-4003-N1
- MA7200-4005-N1
- MA7200-4007-N1
- MA7200-4010-N1

### ■ Removing the digital operator

Take off the screws in the place a. and b.

Press the lever on the side of the digital operator in the direction of arrow 1 to unlock the digital operator.

Disconnect the RS-232 cable connector on the back side of the LCD digital operator. Lift the digital operator in the direction of arrow 2 to remove the digital operator.

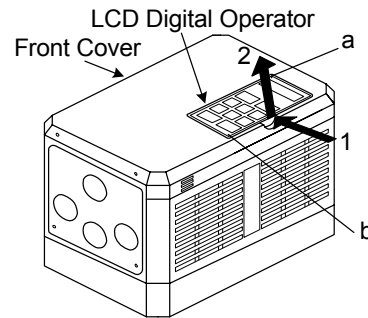

### ■ Removing the front cover

Press the left and right sides of the front cover in the directions of arrow 1 and lift the bottom of the cover in the direction of arrow 2 to remove the front cover.

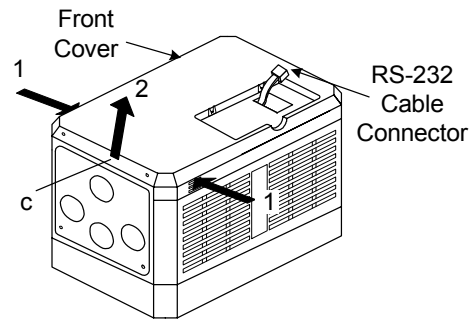

### ■ Mounting the front cover and digital operator

Insert the tab of the upper part of front cover into the groove of the inverter and press the lower part of the front cover onto the inverter until the front cover snaps shut.

Connecting the RS-232 cable connector on the back side of the LCD digital operator and hook the digital operator at a on the front cover in the direction of arrow 1.

Press the digital operator in the direction of arrow 2 until it snaps in the place b and then tighten the screws in the place c and d. (on the front cover)

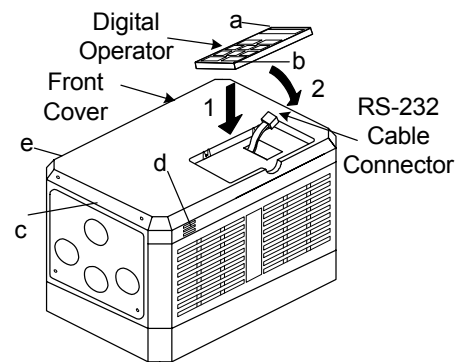

(C) For 230V 15,20HP and 460V 15,20HP Series

- MA7200-2015-N1      • MA7200-4015-N1
- MA7200-2020-N1      • MA7200-4020-N1

■ Removing the digital operator :

Take off the screws in the place a. and b. Disconnect the RS-232 cable connector on the back side of the LCD digital operator and then lift the digital operator upwards.

■ Removing the front cover :

Loosen the two screws of the front cover in the place c and d. And lift the bottom of the front cover to remove the front cover.

■ Mounting the front cover and digital operator :

Insert the tab of the upper part of front cover into the groove of the inverter and tighten the screws in the place c and d.

Connect the RS-232 cable connector on the back of the LCD digital operator.

Attach the digital operator and tighten the screws in the place a and b.

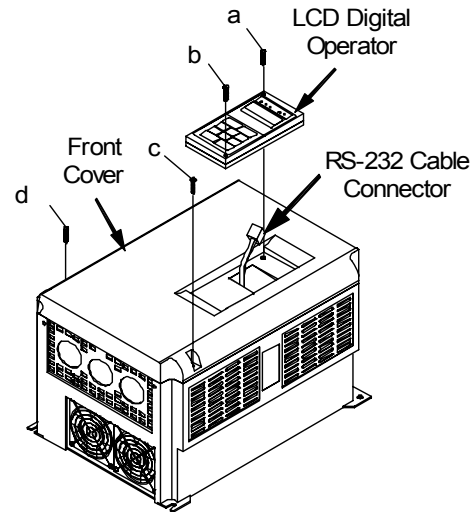

(D) For 230V 30~40HP and 460V 40~75HP Series

■ Removing the front cover: Loosen the two screws of the front cover in the place a. and b. Then loosen the two screws c and d, lift the front cover upwards. (Don't removing the digital operator.)

■ Mounting the front cover: Press the front cover and then tighten the screws in the place a, b, c and d.

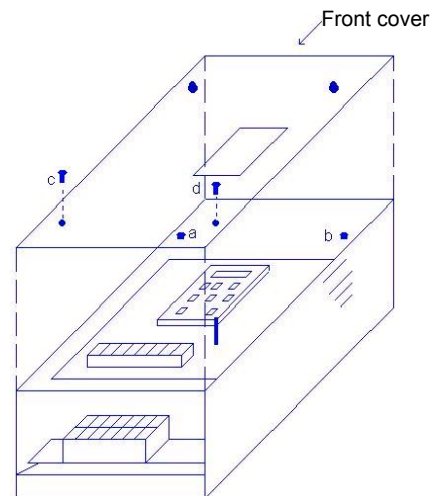

## 1.4 Wiring between Inverter and Peripheral devices and notice



### CAUTION

1. After turning OFF the main circuit power supply, do not touch the circuit components or change any circuit components before the “CHARGE” lamps extinguished. (It indicates that there is still some charge in the capacitor).
2. Never do wiring work or take apart the connectors in the inverter while the power is still on.
3. Never connect the inverter output U/T1, V/T2, W/T3 to the AC source.
4. Always connect the ground lead E to ground.
5. Never apply high voltage test directly to the components within the inverter. (The semiconductor devices are vulnerable to high voltage shock.)
6. The CMOS IC on the control board is vulnerable to ESD. Do not try to touch the control board.
7. If Sn-03 is 7,9,11 (2-wire mode) or is 8, 10, 12 (3-wire mode), except parameter settings of Sn-01 and Sn-02, the other parameter settings will return to their initial settings at factory. If the inverter is initially operated in 3-wire mode (Sn-03= 8, 10, 12), the motor will rotate in CCW sense after setting changed to 2-wire mode. (Sn-03= 7, 9, 11). Be sure that the terminals 1 and 2 are OPEN so as not to harmful to personal or cause any potential damage to machines.



### CAUTION

1. Determine the wire size for the main circuit so that the line voltage drop is within 2% of the rated voltage. If there is the possibility of excessive voltage drop due to wire length, use a larger wire (larger diameter) suitable to the required length  
$$\text{Line voltage drop(V)} = \sqrt{3} \times \text{wire resistance}(\Omega/\text{km}) \times \text{wire length(m)} \times \text{current(A)} \times 10^{-3}$$
2. If the length of the cable wire between the inverter and the motor exceeds 30m, use a lower carrier frequency for PWM (adjust the parameter Cn-34). Refer to Page 3-21

Example of connection between the MA7200 and typical peripheral devices are shown as below.

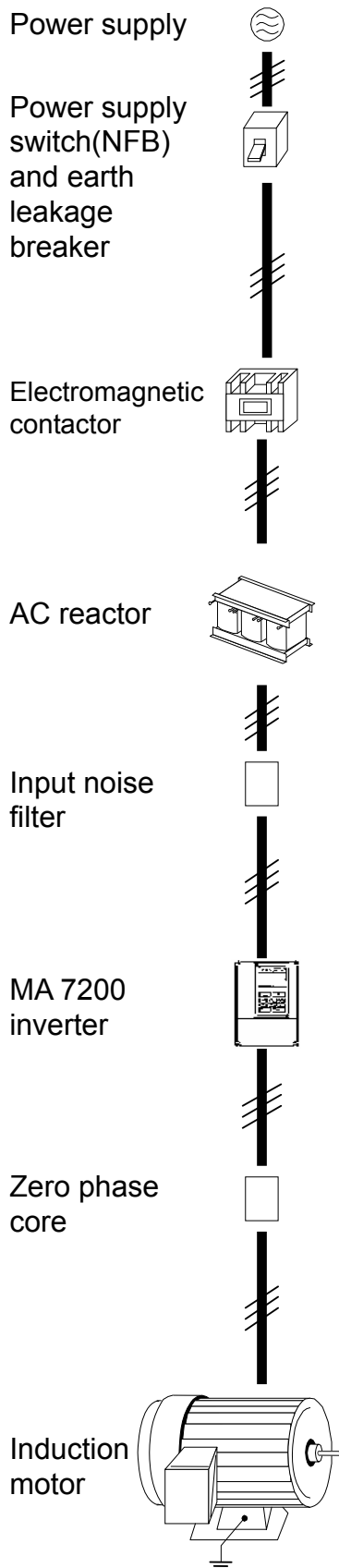

- MCCB (Molded-Case Circuit Breaker)

  - Choose the Molded Case Circuit Breaker (MCCB) of proper current rating. Please refer to the selection guide “1.10 Peripheral Units” on Page 1-22.
  - Do not use a circuit breaker for start/stop operation.
  - When a ground fault interrupter is used, select the one with no influence for high frequency. Setting current should be 200mA or above and the operating time at 0.1 second or longer to avoid false triggering.
  
- MC (Magnetic Contactor)

  - It is not always necessary to have a Magnetic Contactor on the input side. However, an input Magnetic Contactor can be used to prevent an automatic restart after recovery from an external power loss during remote control operation.
  - Do not use the Magnetic Contactor for start/stop operation.
  
- AC Reactor

  - To improve power factor or to reduce surge current, install an AC Reactor on the input side of the MA7200.
  
- Input Noise Filter

  - When used with TECO specified Input Noise Filter, the MA7200 will comply with EN55011 class A regulation.
  - Please refer to the selection guide “1.10 Peripheral Units” on page 1-22.
  
- MA7200 Inverter

  - The input power supply can be connected to any terminal R/L1, S/L2, T/L3 on the terminal block.
  - Please connect the ground terminal E to the site ground securely.
  
- Output Noise Filter (Zero Phase Core)

  - Install an Output Noise Filter between the MA7200 and the Induction Motor to eliminate noise transmitted between the power line and the inverter.
  - Please refer to the selection guide “1.10 Peripheral Devices” on page 1-22.
  
- Induction Motor

  - When multiple motors are driven in parallel with an inverter, the inverter rated current should be at least 1.1 times the total motor rated current.
  - The inverter and the motor must be separately grounded.

## Standard Connection Diagram

The standard connection diagram of MA7200 is shown in Fig. 2. The sign  $\odot$  indicates the main circuit terminal and the sign  $\circ$  indicates control circuit terminal. The terminal function and arrangement are summarized in Table 1 and Table 2. There are three types of control board, the terminal arrangement is shown as below.

(A) For Compact Size Type 230V : 1-2HP, 460V : 1-2HP (NEMA4 are the same)

- MA7200-2001/2-N1
- MA7200-4001/2-N1

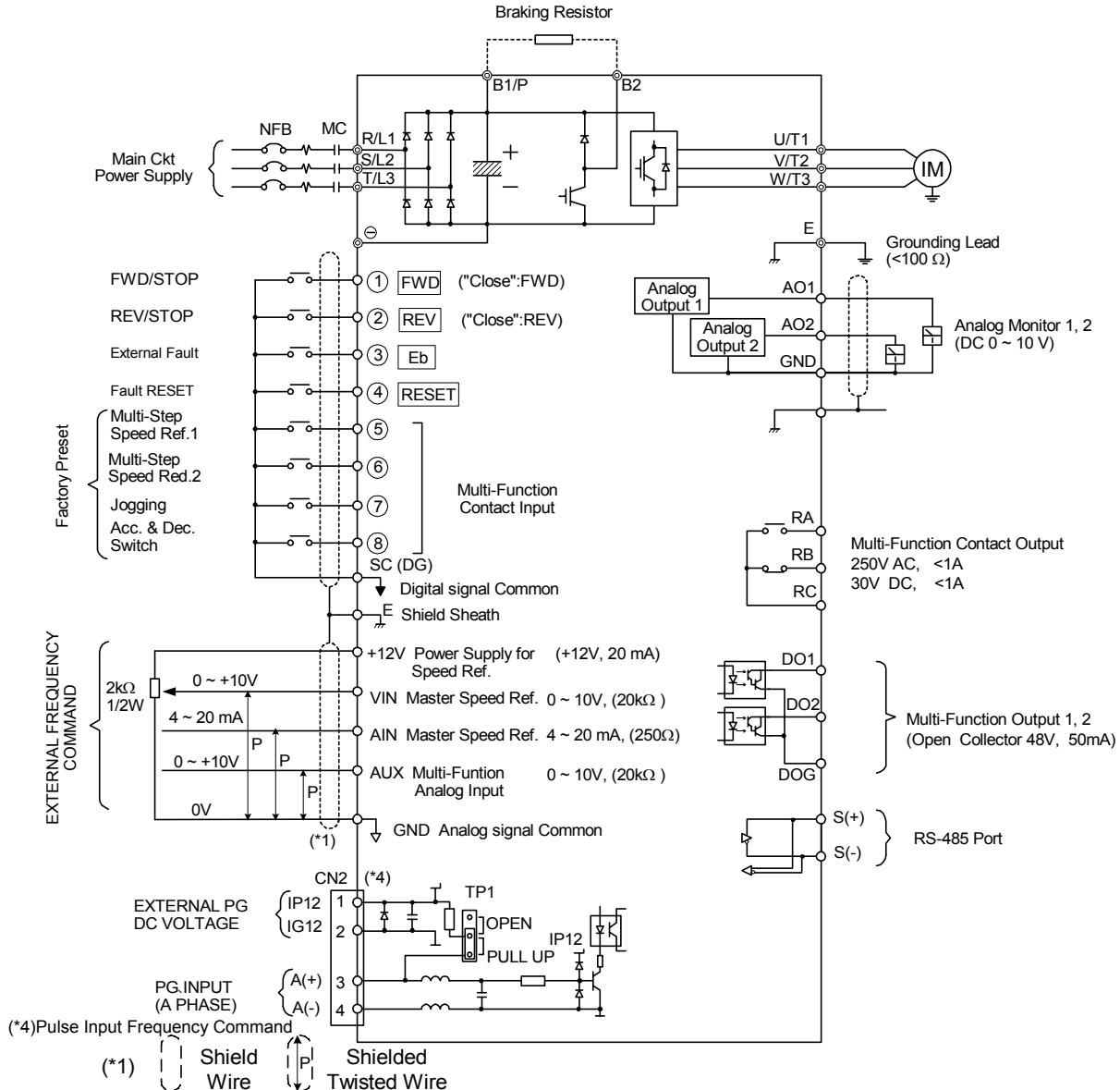

(\*2) The terminal arrangement

SC	1	3	5	7	VIN	AIN	AUX	DO1	DO2	DOG	S(-)
	E	2	4	6	8	+12V	GND	GND	AO1	AO2	S(+)
											E

(\*3) The control board code No. : 4P101C0040001

(\*4) The CN2 wire code No. : 4H339D0250001

Fig. 2-a Standard connection diagram

(B) 230V : 3-40HP, 460V : 3-75HP (NEMA4 to 20HP)

• MA7200-2003-N1  
through  
MA7200-2040-N1

• MA7200-4003-N1  
through  
MA7200-4075-N1

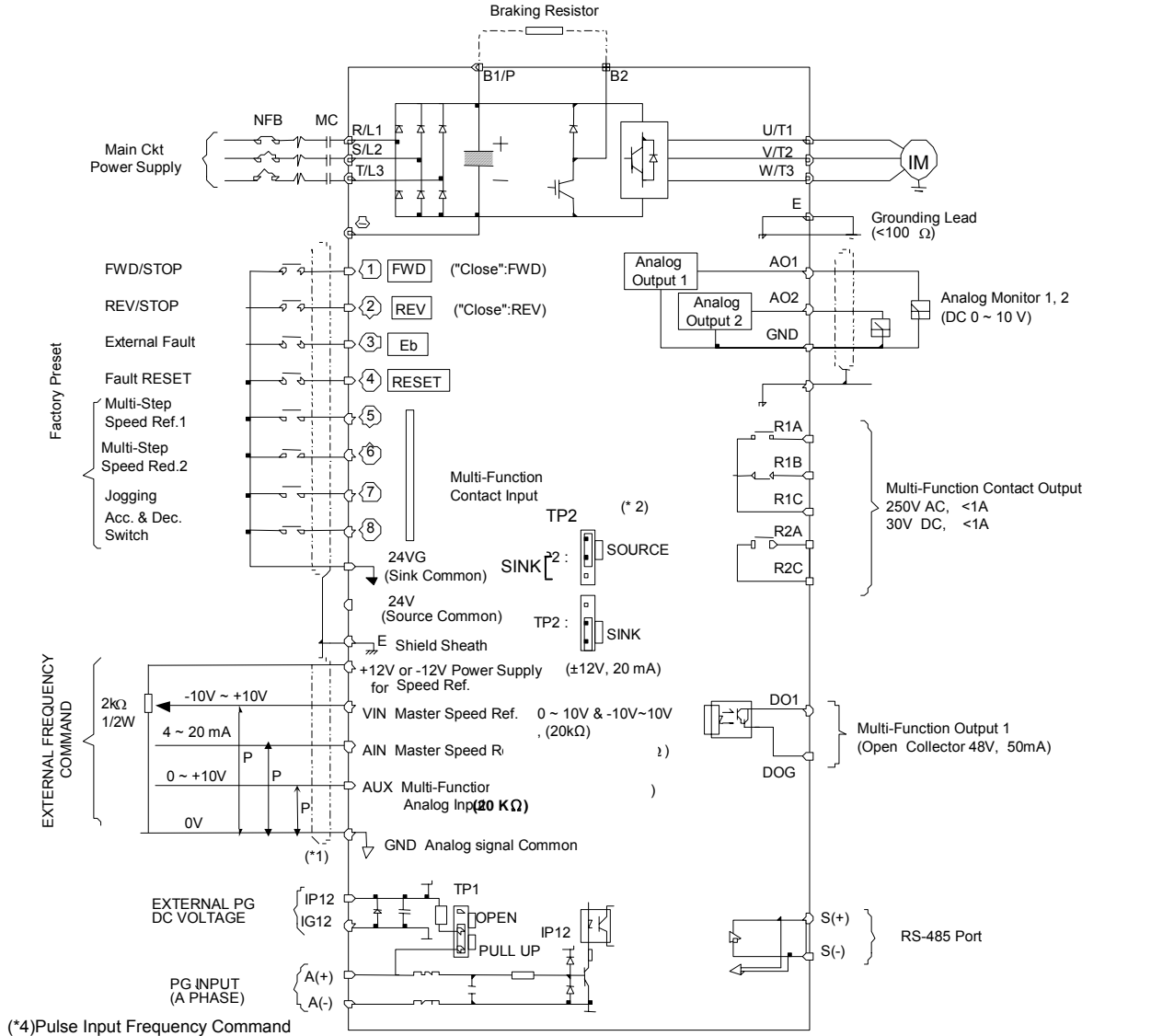

(\*1) Shield Wire Shielded Twisted Wire

(\*2) The terminal ① and ⑧ can be set as SINK or SOURCE type input interface, when setting ①~⑧ as sink type input, the short jumper of TP2 must be set to SINK position, and set to SOURCE position for source type input.

(\*3) VIN Ref. can be set in two input methods as 0~10V or -10~+10V

(\*4) The terminal A(+), A(-) can be the output terminal of Pulse Input Frequency Command, and the jumper of TP1 must be set to OPEN position.

Pulse Input Frequency Command: 0~32KHz, 3~12V High torsion, input resistor 2.7K $\Omega$

(\*5) The terminal arrangement

24VG	1	3	5	7	24V	VIN	AIN	AUX	DO1	DOG	IP12	A(+)	A(-)	
	E	2	4	6	8	+12V	-12V	GND	AO1	AO2	E	IG12	S(+)	S(-)

R2A	R2C	R1A	R1B	R1C
-----	-----	-----	-----	-----

(\*6) The control board code No. : 4P101C0130001

Fig. 2-b Standard connection diagram

## 1.5 Description of terminal function

**Table 1 Main circuit terminals**

Terminal	230V:1~20HP, 460V:1~20HP	230V:25~40HP, 460V:25~75HP
R/L1	Main circuit input power supply (For single phase power supply, please use R/L1, S/L2 as input terminal)	
S/L2		
T/L3		
B1/P	B1/P, B2: External braking resistor B1/P, $\ominus$ : DC power supply input	-
B2		
$\ominus$		• $\oplus$ - $\ominus$ : DC power supply or braking unit
$\oplus$	-	
B2/R	Unused	-
U/T1	Inverter output	
V/T2		
W/T3		
E	Grounding lead (3rd type grounding)	

### Terminal block configuration

- 230V : 1 ~ 2HP

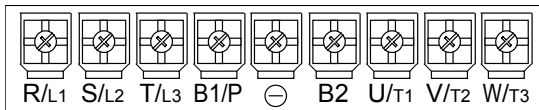

- 460V : 1 ~ 2HP

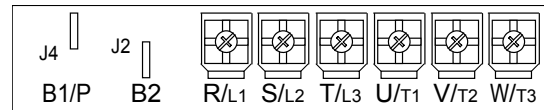

- 230V : 3~5HP

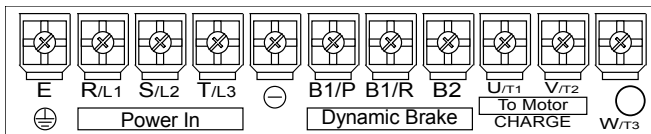

- 460V : 3~5HP

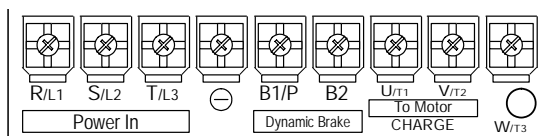

- 230V/460V : 7.5~10HP

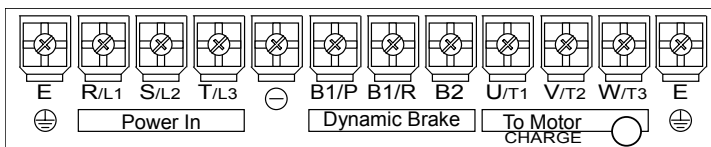

- 230V/460V : 15~20HP

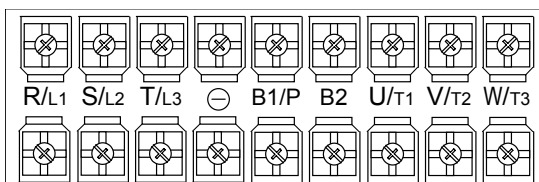

- 230V : 25~40HP, 460V : 25~75HP

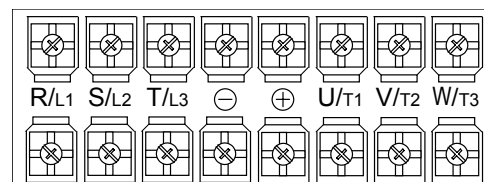

**Table 2 Control circuit terminals**

Terminal	Functions	
1(DI1)	Forward Operation – Stop Signal	
2(DI2)	Reverse Operation – Stop Signal	
3(DI3)	External Fault Input	
4(DI4)	Fault Reset	
5(DI5)	Multifunction Input Terminal: 3-Wire Operation, Load/Remote Control, Multi-Speed Select, FWD/REV Select, ACC/DEC Choice, ACC/DEC Halting, Base Block, Overheat Warn, PID Control, DC Braking, Speed Search, Up/Down Function, PG Feedback Control, External Fault, Timer function, Multifunction Analog Input Setting	
6(DI6)		
7(DI7)		
8(DI8)		
SC(DG) (24VG)	Digital Signal Ground Sink Common Point (Locate the short jumper of TP2 in SINK position)	
24V	Source Common Point (Locate the short jumper of TP2 in SOURCE position)	
E	Connection to Shield Signal Lead (Frame Ground)	
+15V(+12V)	DC voltage for External Device	
-12V	Only support by the board 4P101C01301	
VIN	Master speed Voltage Reference (0~10V) (4P101C01301 support -10V~10V input)	
AIN	Master speed Current Reference (4~20mA)	
AUX	Auxiliary Analog Input: Auxiliary frequency Command, Frequency Gain, Frequency Bias, Overtorque Detection, Output Voltage Bias, ACC/DEC Ramp, DC-Brake Current, Stall Prevention Current Level during Running Mode, PID Control, Lower-Bound of Frequency Command, Frequency-Jump-4, etc	
GND	Analog Signal Common	
IP12	External Power Source For PG Feedback Use	
IG12		
A(+)	Signal Input of PG (also can be the input terminal of Pulse Input Frequency Command)	
A(-)		
AO1	Analog Multifunction Output Port: Frequency Command, Output Frequency, Output Current, Output Voltage, DC Voltage, PID Controlled Value, Analog Command Input of VIN, AIN or AUX.(Below 2mA)	
AO2		
GND		
RA(R1A)	Relay Contact Output A	Same function as terminal DO1, DO2
RB(R1B)	Relay Contact Output B	
RC(R1C)	Relay Contact Common	
DO1	Digital Multi-Function (Open Collector) Output “1”, “2” Terminals: During-Running, Zero-speed, Agreed-frequency, Agree-frequency-setting, Frequency-Output, Inverter-Operation-Ready, Undervoltage-Detection, Base-Block Output, Run Source, Frequency command, Overtorque Detection, Frequency Command Invalid, Fault, Undervoltage, Overheat, Motor Overload, Inverter Overload, During-Retry, Communication-Fault, Timer-Function-Output	
DO2 ( R2A R2B)		
DOG	Common Terminal (of Open Collector Transistor)	
S(+)	RS-485 Port	
S(-)		



**Caution**

- Use the control circuit terminals VIN, AIN according the setting of Sn-24.
- The MAX. Output current at terminal (+15V or +12V) is 20mA.
- The multi-function analog output terminals AO1, AO2 is a dedicated output for a frequency meter, ammeter, etc. Do not use these 2 analog outputs for feedback control or any other control purpose.

## 1.6 Main Circuit Wiring Diagram

Main Circuit Wiring Diagram of MA7200:

1. 230V/460V : 1~20HP

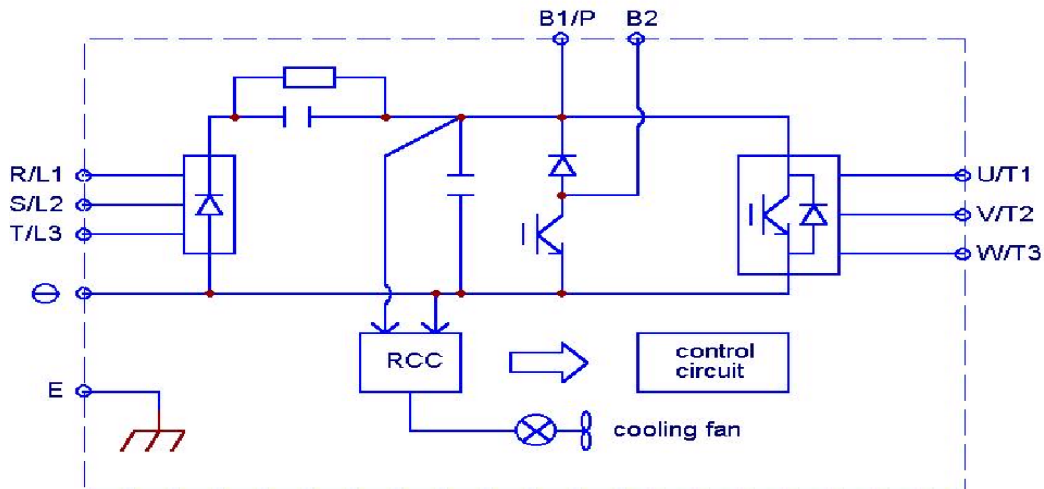

2. 230V : 25HP    460V : 25~30HP

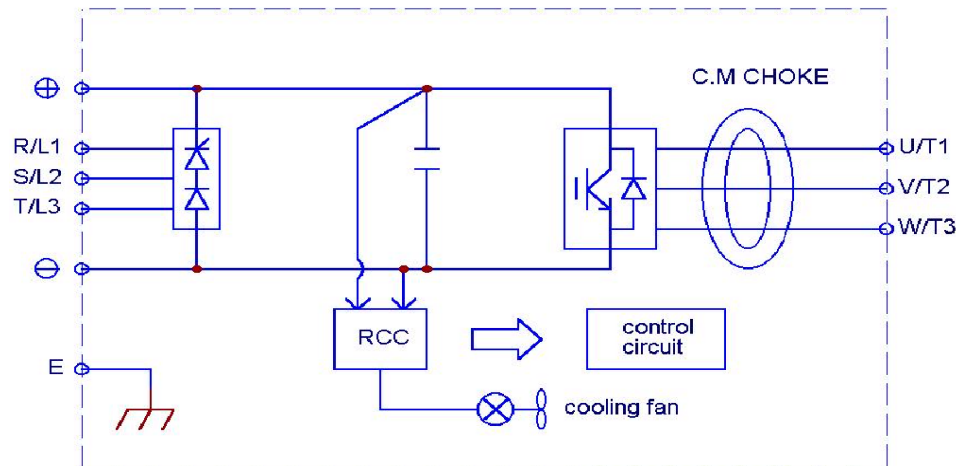

3. 230V : 30~40HP    460V : 40~75HP    DC Reactor built-in

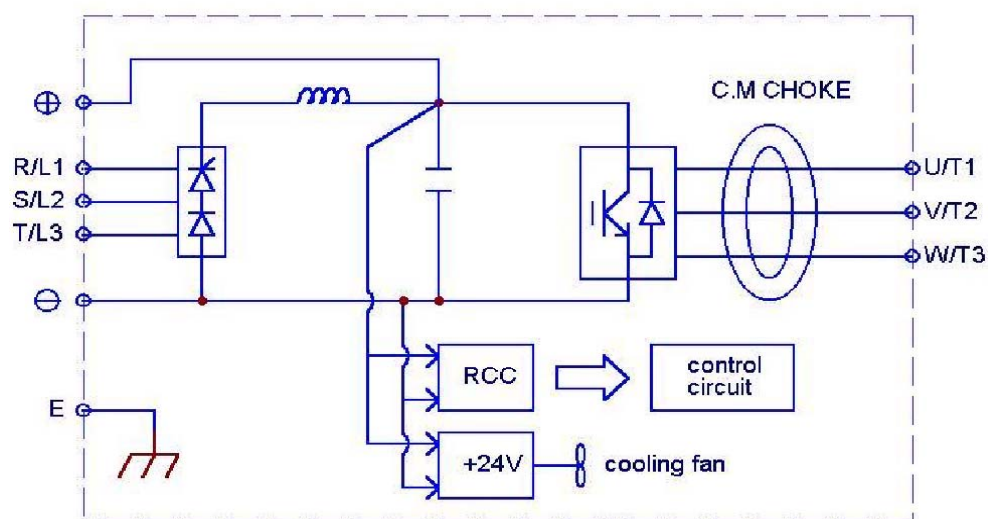

## 1.7 Wiring main circuit and notice

### ■ Main circuit wiring

The non-fusible-breaker (NFB) should be installed between the AC source and the R/L1-S/L2-T/L3 input terminal of MA7200 inverter. The user can make his own decision of installing electromagnetic contactor block (MCB) or not. To protect against the false triggering of leakage-current, the user should install a leakage current breaker with amperage sensitivity  $\geq 200\text{mA}$  and operation time  $\geq 0.1$  sec.

**Table 3 230V and 460V class applicable wire size and connector**

MA7200 model				Wire size (mm <sup>2</sup> )			NFB <sup>*4</sup>	MCB <sup>*4</sup>
Power supply	Applicable Power Rating (HP) <sup>*1</sup>	Rated KVA	Rated current (A)	Main circuit <sup>*2</sup>	Ground connection wire E (G)	Control wire <sup>*3</sup>		
230V 1Φ/3Φ	1HP	2	4.8	2~5.5	2~5.5	0.5~2	TO-50EC(15A)	CN-11
	2HP	2.7	6.4	2~5.5	3.5~5.5	0.5~2	TO-50EC(20A)	CN-11
	3HP	4	9.6	3.5~5.5	3.5~5.5	0.5~2	TO-50EC(20A)	CN-11
230V 3Φ	5.4HP	7.5	17.5	5.5	5.5	0.5~2	TO-50EC(30A)	CN-16
	7.5HP	10.1	24	8	5.5~8	0.5~2	TO-100S(50A)	CN-18
	10HP	13.7	32	8	5.5~8	0.5~2	TO-100S(60A)	CN-25
	15HP	20.6	48	14	8	0.5~2	TO-100S(100A)	CN-50
	20HP	27.4	64	22	8	0.5~2	TO-100S(100A)	CN-65
	25HP	34	80	22	14	0.5~2	TO-225S(150A)	CN-80
	30HP	41	96	38	14	0.5~2	TO-225S(175A)	CN-100
460V 3Φ	40HP	54	130	60	22	0.5~2	TO-225S(175A)	CN-125
	1HP	2.2	2.6	2~5.5	2~5.5	0.5~2	TO-50EC(15A)	CN-11
	2HP	3.4	4	2~5.5	3.5~5.5	0.5~2	TO-50EC(15A)	CN-11
	3HP	4.1	4.8	2~5.5	3.5~5.5	0.5~2	TO-50EC(15A)	CN-11
	5.4HP	7.5	8.7	2~5.5	3.5~5.5	0.5~2	TO-50EC(15A)	CN-18
	7.5HP	10.3	12	3~5.5	3.5~5.5	0.5~2	TO-50EC(20A)	CN-18
	10HP	12.3	15	5.5	5.5	0.5~2	TO-50EC(30A)	CN-25
	15HP	20.6	24	8	8	0.5~2	TO-50EC(30A)	CN-25
	20HP	27.4	32	8	8	0.5~2	TO-100S(50A)	CN-35
	25HP	34	40	8	8	0.5~2	TO-100S(75A)	CN-50
	30HP	41	48	14	8	0.5~2	TO-100S(100A)	CN-50
	40HP	54	64	22	8	0.5~2	TO-100S(100A)	CN-65
	50HP	68	80	22	14	0.5~2	TO-125S(125A)	CN-80
60HP	82	96	38	14	0.5~2	TO-225S(175A)	CN-100	
75HP	110	128	60	22	0.5~2	TO-225S(175A)	CN-125	

\*1 : It is assumed constant torque load.

\*2 : The main circuit has terminals of R/L1, S/L2, T/L3, U/T1, V/T2, W/T3, B1/P, B2/R, B2,  $\Theta$ .

\*3 : The control wire is the wire led to the pin terminals of control board.

\*4 : In Table 3, the specified Part No. of NFB and MC are the item No. of the products of TECO. The customer can use the same rating of similar products from other sources. To decrease the noise interference, be sure to add R-C surge suppressor (R: 10Ω/5W, C: 0.1μF/1000VDC) at the 2 terminals of coils of electromagnetic contactor.

## ■ External circuit wiring precaution:

### (A) Control circuit wiring:

- (1) Separate the control circuit wiring from main circuit wiring (R/L1, S/L2, T/L3, U/T1, V/T2, W/T3) and other high-power lines to avoid noise interruption.
- (2) Separate the wiring for control circuit terminals RA-RB-RC (R1A-R2B-R2C) (contact output) from wiring for terminals ① ~ ⑧, A01, A02, GND, DO1, DO2, DOG 15V(or +12V, -12V), VIN, AIN, AUX, GND, IP12, IG12, A (+), A (-), S(+) and S(-).
- (3) Use the twisted-pair or shielded twisted-pair cables for control circuits to prevent operating faults. Process the cable ends as shown in Fig. 3. The max. wiring distance should not exceed 50 meter.

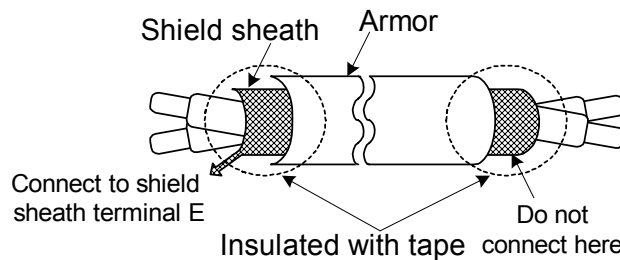

Fig. 3. Processing the ends of twisted-pair cables

When the digital multi-function output terminals connect serially to an external relay, an anti-parallel freewheeling diode should be applied at both ends of relay, as shown below.

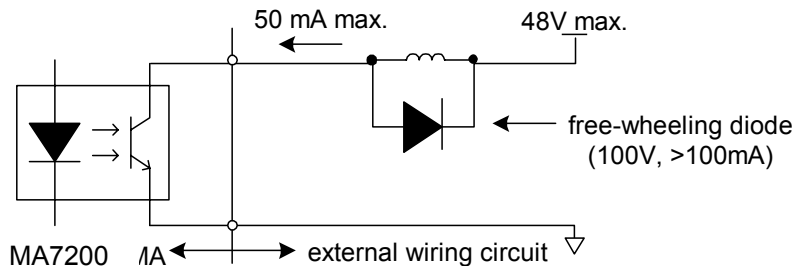

Fig. 4. The Optical-couplers connect to external inductive load

### (B) Wiring the main circuit terminals:

- (1) Input power supply can be connected to any terminal R/L1, S/L2 or T/L3 on the terminal block. The phase sequence of input power supply is irrelevant to the phase sequence.
- (2) Never connect the AC power source to the output terminals U/T1, V/T2 and. W/T3.
- (3) Connect the output terminals U/T1, V/T2, W/T3 to motor lead wires U/T1, V/T2, and W/T3, respectively.
- (4) Check that the motor rotates forward with the forward run source. Switch over any 2 of the output terminals to each other and reconnect if the motor rotates in reverse with the forward run source.
- (5) Never connect a phase advancing capacitor or LC/RC noise filter to an output circuit.

(C) GROUNDING :

- (1) Always use the ground terminal (E) with a ground resistance of less than  $100\Omega$ .
- (2) Do not share the ground wire with other devices, such as welding machines or power tools.
- (3) Always use a ground wire that complies with the technical standards on electrical equipment and minimize the length of ground wire.
- (4) When using more than one inverter, be careful not to loop the ground wire, as shown below.

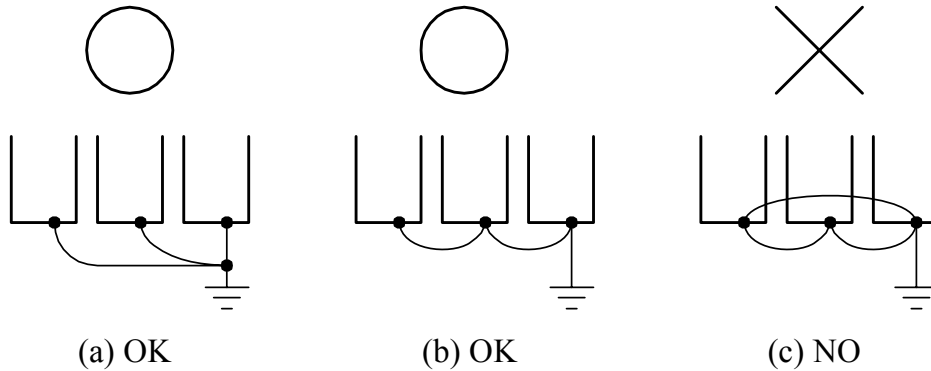

Fig. 5. MA7200 ground winding

- Determine the wire size for the main circuit so that the line voltage drop is within 2% of the rated voltage. (If there is the possibility of excessive voltage drop, use a larger wire suitable to the required length)
- Installing an AC reactor  
If the inverter is connected to a large-capacity power source (600kVA or more), install an optional AC reactor on the input side of the inverter. This also improves the power factor on the power supply side.
- If the cable between the inverter and the motor is long, the high-frequency leakage current will increase, causing the inverter output current to increase as well. This may affect peripheral devices. To prevent this, adjust the carrier frequency, as shown below:

Cable length	< 100ft.	100-165ft.	166-328ft.	$\geq$ 329ft.
Carrier frequency (Cn-34)	15kHz max (Cn-34=6)	10kHz max (Cn-34=4)	5kHz max (Cn-34=2)	2.5kHz (Cn-34=1)

## 1.8 Inverter Specifications

### ■ Basic Specifications

#### (a) 230V Series

Inverter (HP)		1	2	3	5	7.5	10	15	20	25	30	40	
Max. Applicable Motor Output HP*1 (KW)		1 (0.75)	2 (1.5)	3 (2.2)	5.4 (4)	7.5 (5.5)	10 (7.5)	15 (11)	20 (15)	25 (18.5)	30 (22)	40 (30)	
Output Characteristics	Rated Output Capacity (KVA)	2	2.7	4	7.5	10.1	13.7	20.6	27.4	34	41	54	
	Rated Output Current (A)	4.8	6.4	9.6	17.5	24	32	48	64	80	96	130	
	Max. Output Voltage (V)	3-Phases, 200V~230V											
	Max. Output Frequency (Hz)	Through Parameter Setting 0.1~400.0 Hz											
Power Supply	Rated Voltage, Frequency	1PH/3PH 200V~230V, 50/60Hz			3-Phases, 200V~230V, 50/60Hz								
	Allowable Voltage Fluctuation	-15% ~ +10%											
	Allowable Frequency Fluctuation	±5%											

#### (b) 460V Series

Inverter (HP)		1	2	3	5	7.5	10	15	20	25	30	40	50	60	75
Max. Applicable Motor Output HP*1 (KW)		1 (0.75)	2 (1.5)	3 (2.2)	5.4 (4)	7.5 (5.5)	10 (7.5)	15 (11)	20 (15)	25 (18.5)	30 (22)	40 (30)	50 (37)	60 (45)	75 (55)
Output Characteristics	Rated Output Capacity (KVA)	2.2	3.4	4.1	7.5	10.3	12.3	20.6	27.4	34	41	54	68	82	110
	Rated Output Current (A)	2.6	4	4.8	8.7	12	15	24	32	40	48	64	80	96	128
	Max. Output Voltage (V)	3-Phases, 380V~460V													
	Max. Output Frequency (Hz)	Through Parameter Setting 0.1~400.0 Hz													
Power Supply	Rated Voltage, Frequency	3-Phases, 380V ~ 460V · 50/60Hz													
	Allowable Voltage Fluctuation	-15% ~ +10%													
	Allowable Frequency Fluctuation	±5%													

\*1. Based on 4 pole motor

\*2. The spec. of NEMA4 are the same

## ■ General Specifications

Control Characteristics	Operation Mode	Graphic LCD Panel (English and Chinese) with parameters copying (LED: option)
	Control Mode	Sinusoidal PWM
	Frequency Control Range	0.1Hz ~ 400Hz
	Frequency Accuracy (varied with temperature)	Digital Command: $\pm 0.01\%$ (-10 ~ +40°C), Analog Command: $\pm 0.1\%$ (25°C $\pm 10^\circ\text{C}$ ),
	Speed Control Accuracy	$\pm 0.1\%$ (V/F with PG feedback), $\pm 0.5\%$ (Sensorless Vector Control)
	Frequency Command Resolution	Digital Command: 0.01Hz Analog Command: 0.06Hz/60Hz
	Frequency Output Resolution	0.01Hz
	Overload Resistibility	150% Rated Current for 1 Min
	Frequency Setting Signal	DC 0~+10V / 4~20 mA, DC-10V~+10V and Pulse Input Frequency Command (Above 230V/460V 3HP)
	Acc./Dec. Time	0.0~6000.0 sec ( Accel/Decel Time Can Be Set Independently)
	Voltage-Frequency Characteristics	V/F Curve Can Be Set Through Parameter Setting
	Regeneration Torque	Approx. 20%
	Protection Function	Basic Control Function
Extra Function		Cumulative Power on & Operation Hour memory, Energy Saving, Up/Down Operation, 4 Different sets of Fault Status Record (Including Latest one), MODBUS Communication, Multiple-Pulse Output Ports, Select Local/Remote, Customer Application Software Environment (C.A.S.E), SINK/SOURCE Interface.
Stall Prevention		During Acceleration/Deceleration and constant Speed Running (Current Level Can Be Selected During Acceleration and Constant Speed Running. During Deceleration, Stall Prevention Can Be Enabled or Disabled)
Instantaneous Overcurrent		Stopped if above 200% Rated Current
Motor Overload Protection		Electronic Overload Curve Protection
Inverter Overload Protection		Stopped if above 150% Rated Current for 1 Min.
Overvoltage		Stop if VDC $\square$ 410V (230 Class) or VDC $\square$ 820V (460 Class)
Undervoltage		Stop if VDC $\square$ 200V (230 Class) or VDC $\square$ 400V (460 Class)
Momentary Power Loss Ride-Through time		$\square$ 15ms, stop otherwise
Overheat Protection		Protected by Thermistor
Grounding Protection		Protection by DC Current Sensor
Charge Indication (LED)		Lit when the DC Bus Voltage Above 50V
Environmental Condition	Input Phase Loss (IPL)	Motor coasts to stop at Input Phase Loss
	Output Phase Loss (OPL)	Motor coasts to stop at Output Phase Loss
	Application Site	Indoor (No Corrosive Gas And Dust Present)
	Ambient Temperature	-10°C ~ +40°C (Not Frozen)
	Storage Temperature	-20°C ~ +60°C
Communication Function	Ambient Humidity	Below 90%RH (Non-Condensing)
	Height, Vibration	Below 1000M, 5.9m/S <sup>2</sup> (0.6G), (JISC0911 Standard)
	Encoder Feedback Interface	RS-485 Installed (MODBUS Protocol)
	EMI	Built-in PG Feedback Interface and set to Open-collector Interface Drive or Complementary Interface Drive
	EMS Compatibility	Meet EN 61800-3 With Specified EMI Filter
	Option	Meet EN 61800-3
		PROFIBUS Card

## 1.9 Dimensions

Voltage	Inverter Capacity(HP)	Open Chassis Type (IP00) (mm)						Weight (kg)	Enclosed Type (NEMA1) (mm)						Weight (kg)	ACL/DCL	Reference Figure							
		W	H	D	W1	H1	d		W	H	D	W1	H1	d										
230V 1/3Φ	1							-	132	217	143.5	122	207	M5	2.3	External ACL (option)	(a)							
	2								140	279.5	176.5	126	226	M6	4.3									
	3								140	279.5	176.5	126	226	M6	4.3									
230V 3Φ	5							-	211.2	300	215	192	286	M6	5.7		External ACL (option)	(b)						
	7.5								265	360	225	245	340	M6	12									
	10														13									
	15														31									
	20														32									
	25																							
	30								269	553	277	210	530	M10	30	269	647	277	210	530	M10	31	DCL Built-in (Standard)	(c)
	40														31									
460V 3Φ	1							-	132	217	143.5	122	207	M5	2.3	External ACL (option)	(b)							
	2								140	279.5	176.5	126	226	M6	4.3									
	3								211.2	300	215	192	286	M6	5.7									
	5								265	360	225	245	340	M6	12									
	7.5														13									
	10														31									
	15														32									
	20								269	553	277	210	530	M10	30	269	647	277	210	530	M10	31	DCL Built-in (Standard)	(c)
	25														46									
	30																							
	40								308	653	282	250	630	M10	46	308	747	282	250	630	M10	47		
	50																							
	60																							
75																								

(a) 230V / 460V : 1~2HP

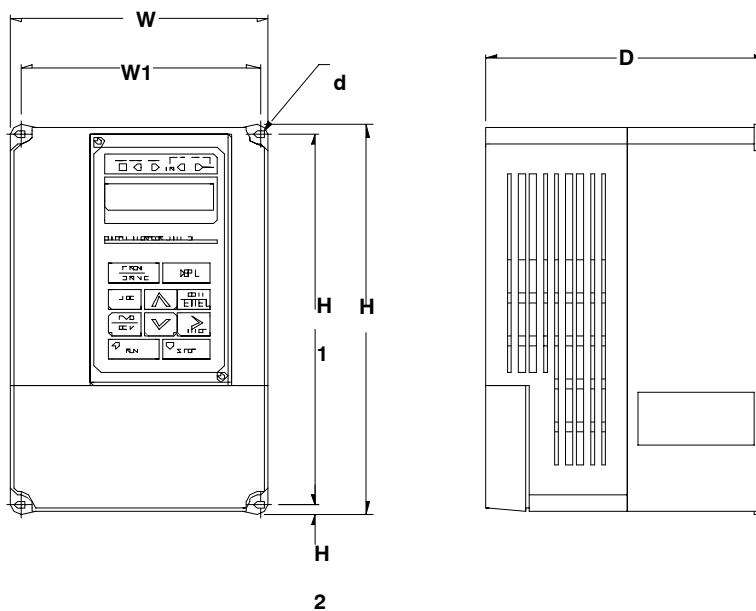

(b) 230V : 3HP~25HP  
 460V : 3HP~30HP

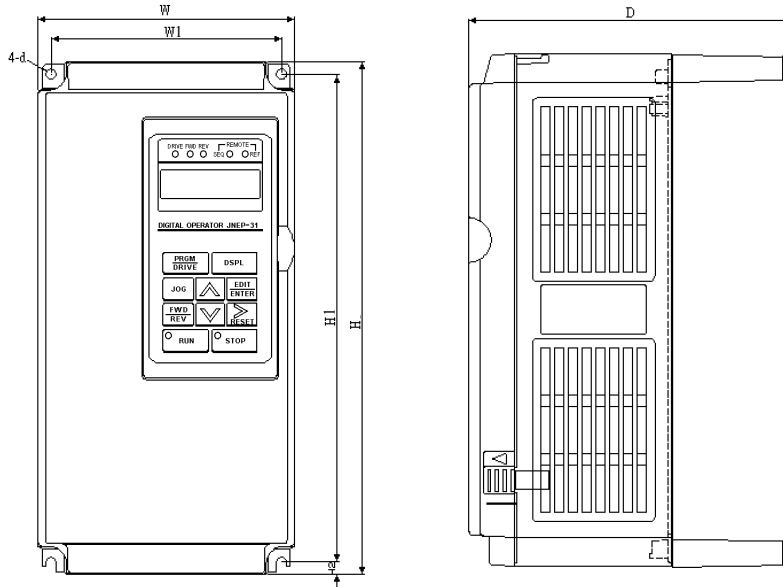

(c) 230V : 30HP~40HP  
 460V : 40HP~75HP

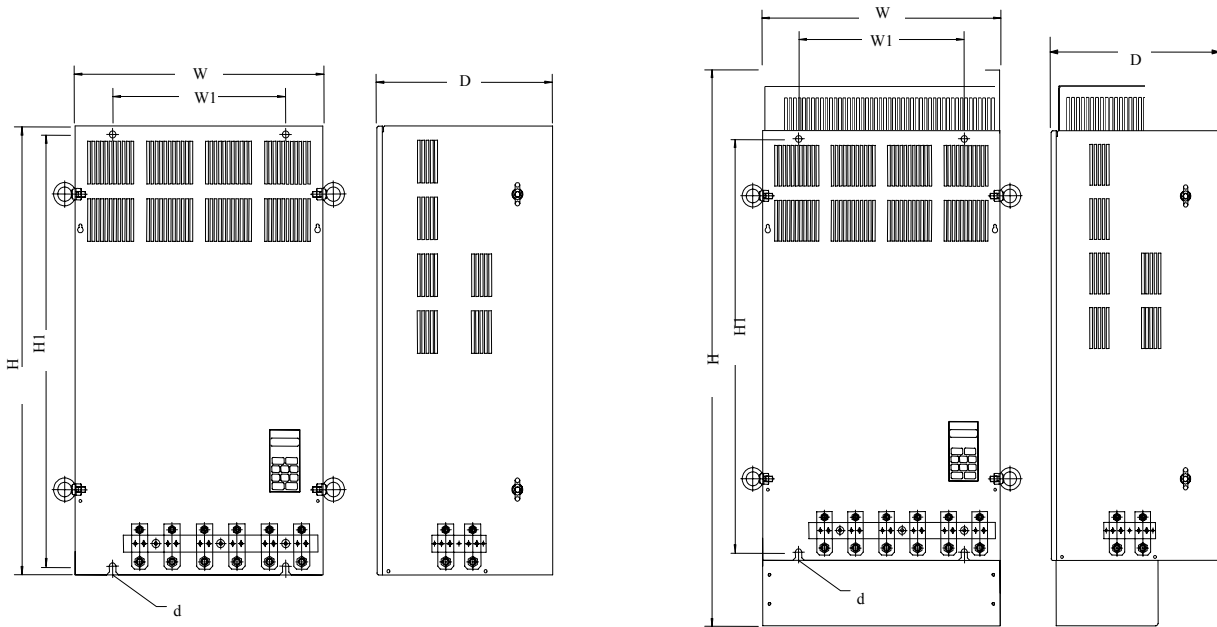

( Open Chassis Type — IP00 )

( Enclosed, Wall-mounted Type — NEMA1 )

(d) NEMA4 Type : 1HP~20HP

Voltage	Inverter Capacity(HP)	NEMA4 (mm)						Weight (kg)
		W	H	D	W1	H1	d	
230V 1/3Φ	1	198	335	217	115	315	M6	6.3
	2							7.5
	3							7.5
230V 3Φ	5	223	460	245	140	440	M6	7.5
	7.5							16
	10							
	15							
	20							
460V 3Φ	1	198	335	217	115	315	M6	6.3
	2							7.5
	3							
	5							
	7.5	223	460	245	140	440	M6	16
	10							
	15							
	20							

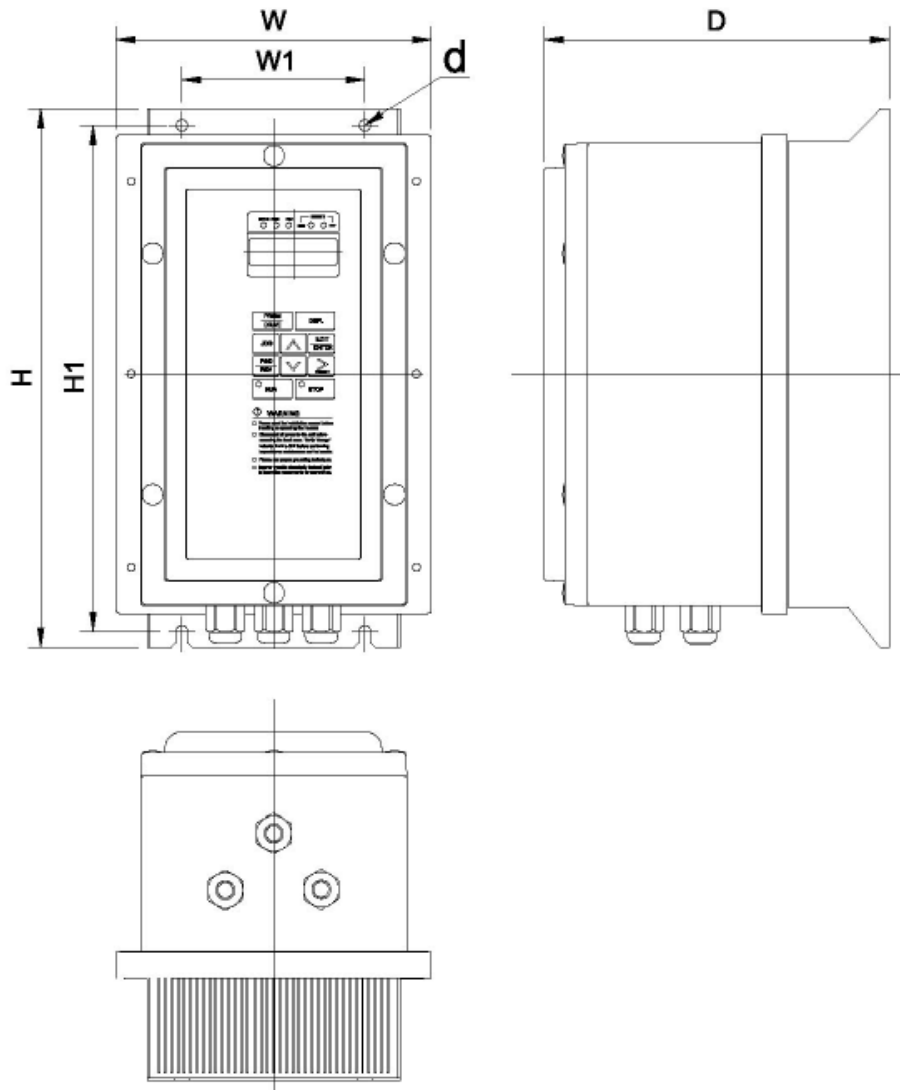

## 1.10 Peripheral Units

### ■ Braking resistors

MA7200 230V/460V 1~20HP model have built-in braking transistor, and can be connected external braking resistor between B1/P and B2 when lack of braking ability. Above 25HP models, need to connect braking unit (on  $\oplus$  -  $\ominus$  of inverter) and braking resistors (on B-P0 of braking unit).

**Table 4 Braking resistor list**

Voltage	Inverter		Braking Unit		Braking Resistor			Braking Torque (%)
	HP	Rated current (A)	Model	Number used	Code NO.	Specs.	Number used	
230V 1/3 $\Phi$	1	4.8	-	-	JNBR-150W200	150W/200 $\Omega$	1	119%, 10%ED
	2	6.4	-	-	JNBR-150W100	150W/100 $\Omega$	1	119%, 10%ED
	3	9.6	-	-	JNBR-260W70	260W/70 $\Omega$	1	115%, 10%ED
230V 3 $\Phi$	5	17.5	-	-	JNBR-390W40	390W/40 $\Omega$	1	119%, 10%ED
	7.5	24	-	-	JNBR-520W30	520W/30 $\Omega$	1	108%, 10%ED
	10	32	-	-	JNBR-780W20	780W/20 $\Omega$	1	119%, 10%ED
	15	48	-	-	JNBR-2R4KW13R6	2400W/13.6 $\Omega$	1	117%, 10%ED
	20	64	-	-	JNBR-3KW10	3000W/10 $\Omega$	1	119%, 10%ED
	25	80	JNTBU-230	1	JNBR-4R8KW8	4800W/8 $\Omega$	1	119%, 10%ED
	30	96	JNTBU-230	1	JNBR-4R8KW6R8	4800W/6.8 $\Omega$	1	117%, 10%ED
	40	130	JNTBU-230	2	JNBR-3KW10	3000W/10 $\Omega$	2	119%, 10%ED
460V 3 $\Phi$	1	2.6	-	-	JNBR-150W750	150W/750 $\Omega$	1	126%, 10%ED
	2	4	-	-	JNBR-150W400	150W/400 $\Omega$	1	119%, 10%ED
	3	4.8	-	-	JNBR-260W250	260W/250 $\Omega$	1	126%, 10%ED
	5	8.7	-	-	JNBR-400W150	400W/150 $\Omega$	1	126%, 10%ED
	7.5	12	-	-	JNBR-600W130	600W/130 $\Omega$	1	102%, 10%ED
	10	15	-	-	JNBR-800W100	800W/100 $\Omega$	1	99%, 10%ED
	15	24	-	-	JNBR-1R6KW50	1600W/50 $\Omega$	1	126%, 10%ED
	20	32	-	-	JNBR-1R5KW50	1500W/40 $\Omega$	1	119%, 10%ED
	25	40	JNTBU-430	1	JNBR-4R8KW32	4800W/32 $\Omega$	1	119%, 10%ED
	30	48	JNTBU-430	1	JNBR-4R8KW27R2	4800W/27.2 $\Omega$	1	117%, 10%ED
	40	64	JNTBU-430	1	JNBR-6KW20	6000W/20 $\Omega$	1	119%, 10%ED
	50	80	JNTBU-430	2	JNBR-4R8KW32	4800W/32 $\Omega$	2	119%, 10%ED
	60	96	JNTBU-430	2	JNBR-4R8KW27R2	4800W/27.2 $\Omega$	2	117%, 10%ED
	75	128	JNTBU-430	2	JNBR-6KW20	6000W/20 $\Omega$	2	126%, 10%ED

\*Note 1: Another choices are listed as below.

440V 50HP : (JUVPHV-0060+JNBR-9R6KW16) x 1

440V 60HP : (JUVPHV-0060+JNBR-9R6KW13R6) x 1

\*Note 2: JUVPHV-0060 no UL certification

■ AC reactor

- An AC reactor can be added on the power supply side if the inverter is connected to a much larger capacity power supply system, or the inverter is within short distance (<10m) from power supply systems, or to increase the power factor on the power supply side.
- Choose the proper AC reactor according to the below list.

**Table 5 AC reactor list**

Inverter Model			AC reactor	
V	HP	Rated current	Code No.	Specification (mH/A)
230V 1Φ/3Φ	1	4.8A	3M200D1610021	2.1mH/5A
	2	6.5A	3M200D1610030	1.1mH/10A
	3	9.6A	3M200D1610048	0.71mH/15A
230V 3Φ	5.4	17.5A	3M200D1610056	0.53mH/20A
	7.5	24A	3M200D1610064	0.35mH/30A
	10	32A	3M200D1610072	0.265mH/40A
	15	48A	3M200D1610081	0.18mH/60A
	20	64A	3M200D1610099	0.13mH/80A
	25	80A	3M200D1610102	0.12mH/90A
	30	96A	3M200D1610111	0.09mH/120A
460V 3Φ	40	130A	3M200D1610269	0.07mH/160A
	1	2.6A	3M200D1610137	8.4mH/3A
	2	4A	3M200D1610145	4.2mH/5A
	3	4.8A	3M200D1610153	3.6mH/7.5A
	5.4	8.7A	3M200D1610161	2.2mH/10A
	7.5	12A	3M200D1610170	1.42mH/15A
	10	15A	3M200D1610188	1.06mH/20A
	15	24A	3M200D1610196	0.7mH/30A
	20	32A	3M200D1610200	0.53mH/40A
	25	40A	3M200D1610218	0.42mH/50A
	30	48A	3M200D1610226	0.36mH/60A
	40	64A	3M200D1610234	0.26mH/80A
	50	80A	3M200D1610242	0.24mH/90A
60	96A	3M200D1610251	0.18mH/120A	
75	128A	3M200D1610315	0.15mH/150A	

Note: The AC reactors are applied only to input side. Do not apply it to output side.

■ Noise filter

A. INPUT SIDE NOISE FILTER

- Installing a noise filter on power supply side to eliminate noise transmitted between the power line and the inverter
- MA7200 has its specified noise filter to meet the EN61800-3 class A specification

**Table 6 Noise filter on the input side**

Inverter			Noise Filter				
V	HP	Rated Current (A)	Code		Specifications	Current	Dimensions
230V 1/3Φ	1	4.8A	1Φ	4H300D1750003	JUNF12015S-MA	15 A	Fig. (a)
			3Φ	4H300D1710001	JUNF32012S-MA	12 A	Fig. (a)
	2	6.5A	1Φ	4H300D1750003	JUNF12015S-MA	15 A	Fig. (a)
			3Φ	4H300D1710001	JUNF32012S-MA	12 A	Fig. (a)
	3	9.6A	1Φ	4H300D1600001	JUNF12020S-MA	20 A	Fig. (a)
			3Φ	4H300D1610007	JUNF32024S-MA	24 A	Fig. (a)
230V 3Φ	5.4	17.5A	4H300D1610007		JUNF32024S-MA	24 A	Fig. (a)
	7.5	24A	4H300D1620002		JUNF32048S-MA	48 A	Fig. (b)
	10	32A	4H300D1620002		JUNF32048S-MA	48 A	Fig. (b)
	15	48A	4H300D1730002		JUNF32070S-MA	70 A	Fig. (b)
	20	64A	4H300D1730002		JUNF32070S-MA	70 A	Fig. (b)
460V 3Φ	1	2.6A	4H300D1720007		JUNF34008S-MA	8 A	Fig. (a)
	2	4A	4H300D1720007		JUNF34008S-MA	8 A	Fig. (a)
	3	4.8A	4H300D1630008		JUNF34012S-MA	12 A	Fig. (a)
	5.4	8.7A	4H300D1630008		JUNF34012S-MA	12 A	Fig. (a)
	7.5	12A	4H300D1640003		JUNF34024S-MA	24 A	Fig. (b)
	10	15A	4H300D1640003		JUNF34024S-MA	24 A	Fig. (b)
	15	24A	4H300D1740008		JUNF34048S-MA	48 A	Fig. (b)
	20	32A	4H300D1740008		JUNF34048S-MA	48 A	Fig. (b)
	25	40A	4H000D1770008		KMF370A	70A	Fig. (c)
	30	48A	4H000D1790009		KMF370A	70A	Fig. (c)
	40	64A	4H000D1790009		KMF3100A	100A	Fig. (c)
	50	80A	4H000D1800004		KMF3100A	100A	Fig. (c)
	60	96A	4H000D1800004		KMF3150A	150A	Fig. (c)
75	128A	4H000D1820005		KMF3180A	180A	Fig. (c)	

• Dimension : (unit : mm)

(a)

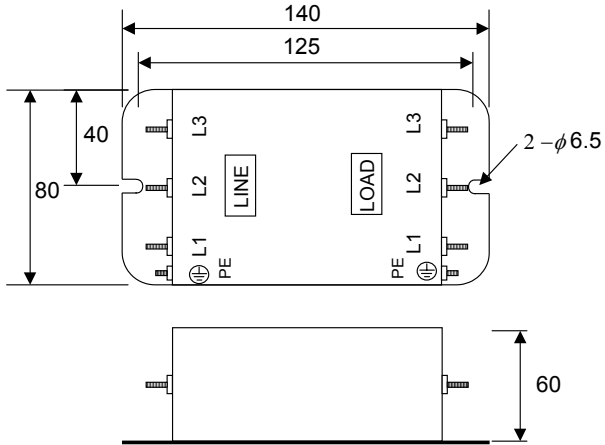

(b)

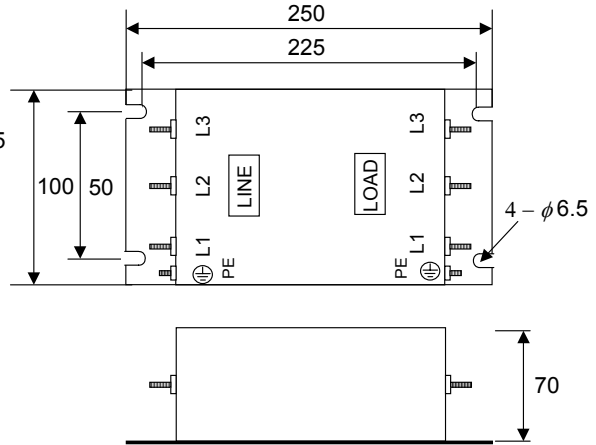

(c)

Model	Dimension (mm)						
	W	W1	H	H1	D	d	M
KMF370A	93	79	312	298	190	7	M6
KMF3100A	93	79	312	298	190	7	M6
KMF3150A	126	112	334	298	224	7	M6
KMF3180A	126	112	334	298	224	7	M6

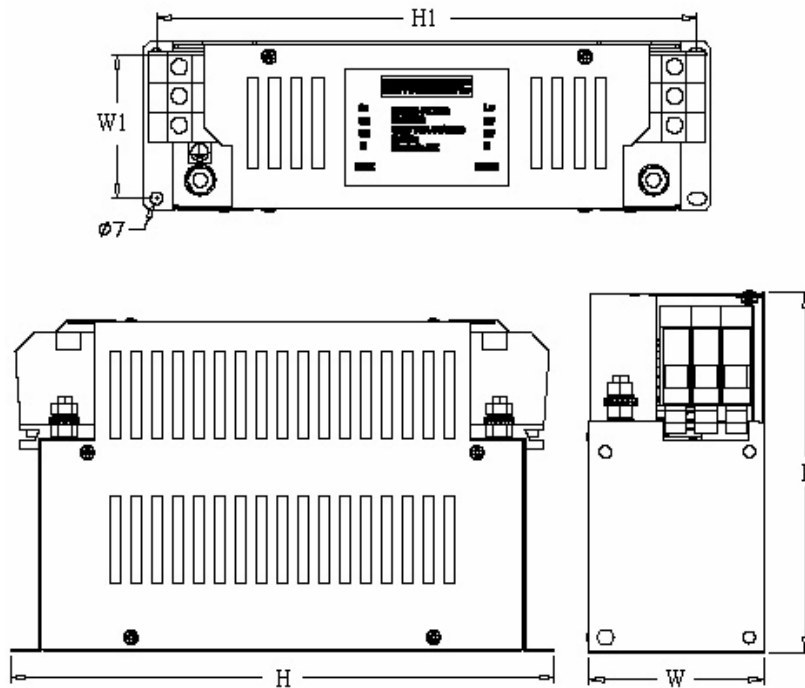

## B. EMI SUPPRESSION ZERO PHASE CORE

- Model : JUNFOC046S — — — — —
- Code No. : 4H000D0250001
- According to the required power rating and wire size, select the matched ferrite core to suppress EMI noise.
- The ferrite core can attenuate the frequency response at high frequency range (from 100KHz to 50MHz, as shown below). It should be able to attenuate the RFI from inverter to outside.
- The zero-sequence noise ferrite core can be installed either on the input side or on the output side. The wire around the core for each phase should be wound by following the same convention and one direction. The more winding turns the better attenuation effect. (Without saturation). If the wire size is too big to be wound, all the wire can be grouped and go through these several cores together in one direction.
- Frequency attenuation characteristics (10 windings case)

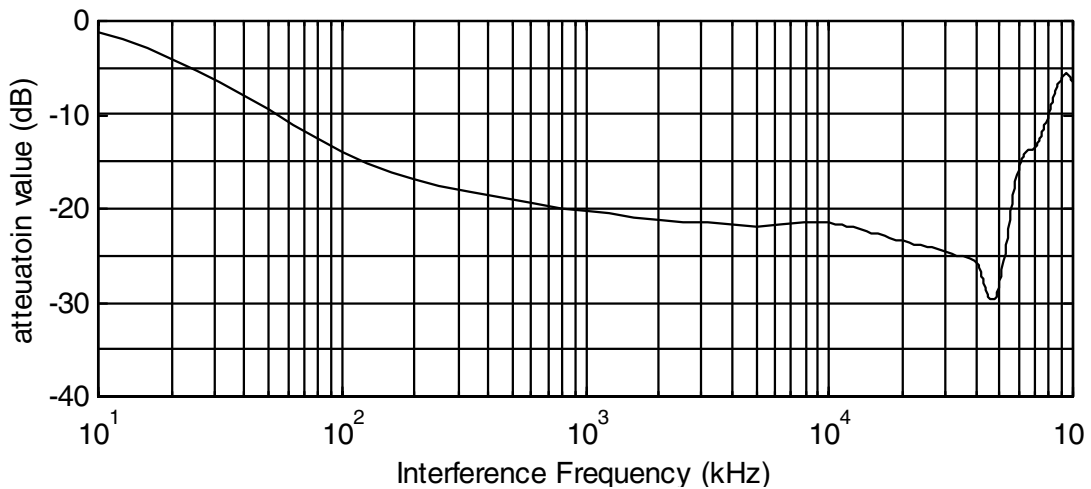

Example: EMI suppression zero phase core application example

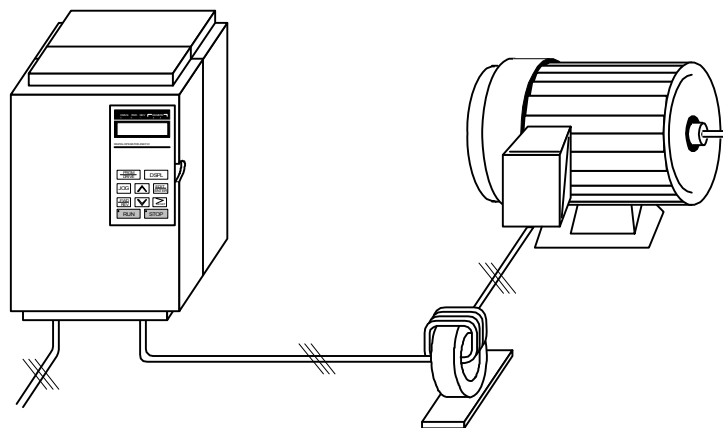

Note: All the line wire of U/T1, V/T2, W/T3 phase must pass through the same zero-phase core in the same winding sense.

## ■ LCD operator with extension wire

When used for remote control purpose, the LCD operator can have different extension wires based upon the applications. Some extension wires are listed below.

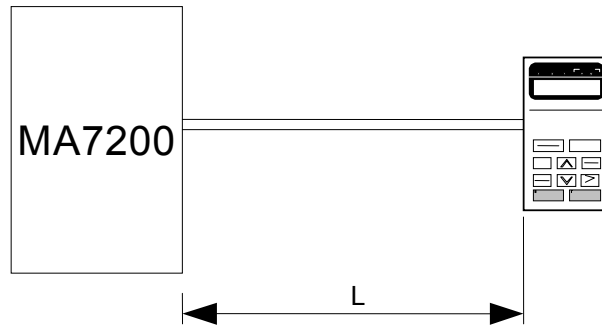

Cable Length	Extension Cable Set *1	Extension Cable *2	Blank Cover *3
1m	4H332D0010000	4H314C0010003	4H300D1120000
2m	4H332D0030001	4H314C0030004	
3m	4H332D0020005	4H314C0020009	
5m	4H332D0040006	4H314C0040000	
10m	4H332D0130005	4H314C0060001	

\*1 : Including special cable for LCD digital operator, blank cover, fixed use screws and installation manual.

\*2 : One special cable for LCD digital operator.

\*3 : A blank cover to protect against external dusts, metallic powder, etc.

The physical dimension of LCD digital operator is drawn below.

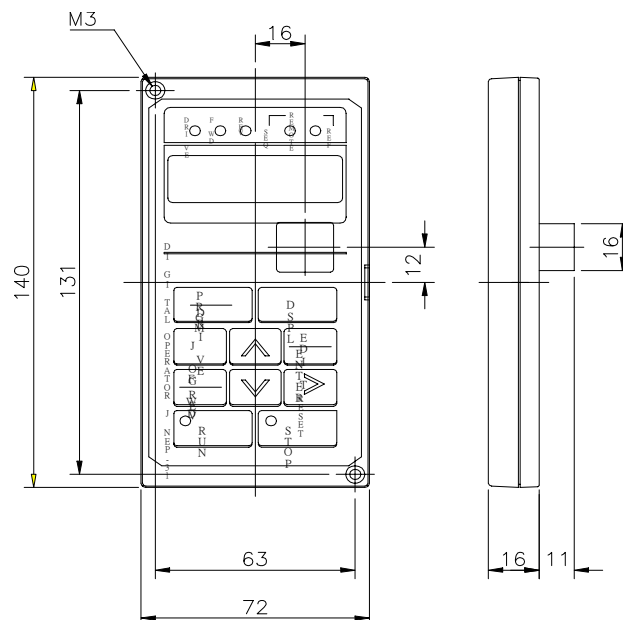

Fig. 6. LCD Digital Operator Dimension

## ■ Analog operator

All MA7200 have the digital LCD digital operator. Moreover, an analog operator as JNEP-16 (shown in fig. 7) is also available and can be connected through wire as a portable operator. The wiring diagram is shown below.

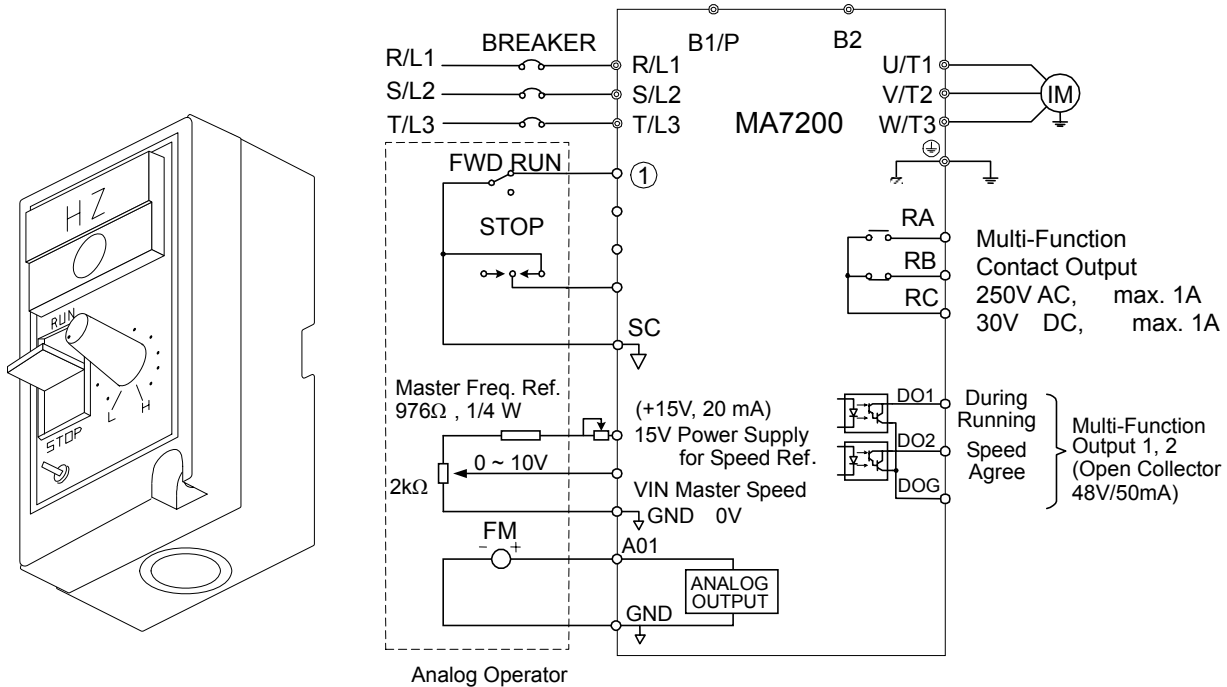

Fig. 7. Analog Operator

## ■ PROFIBUS Communication Card

- Code No. : 4H300D0290009
- Please refer to the appendix D and “MA7200 PROFIBUS-DP Communication Application manual” for communication interface.

## 1.11 FUSE TYPES

### 230V class

MODEL	HP	KVA	100% CONT. Output AMPS	Rated Input AMPS	3Φ FUSE Rating	1Φ FUSE Rating
JNTMBG□□0001JK	1	2	4.8	6	12	15
JNTMBG□□0002JK	2	2.7	6.4	8	15	20
JNTMBG□□0003JK	3	4	9.6	12	20	25
JNTMBG□□0005JK	5	7.5	17.5	21	30	x
JNTMBG□□7R50JK	7.5	10.1	24	29	50	x
JNTMBG□□0010JK	10	13.7	32	38	60	x
JNTMBG□□0015JK	15	20.6	48	58	100	x
JNTMBG□□0020JK	20	27.4	64	77	125	x
JNTMBG□□0025JK	25	34	80	88	125	x
JNTMBG□□0030JK	30	41	96	106	150	x
JNTMBG□□0040JK	40	54	130	143	200	x

### 460V class

MODEL	HP	KVA	100% CONT. Output AMPS	Rated Input AMPS	FUSE Rating
JNTMBG□□0001AZ	1	2.2	2.6	3	6
JNTMBG□□0002AZ	2	3.4	4	5	10
JNTMBG□□0003AZ	3	4.1	4.8	6	10
JNTMBG□□0005AZ	5	7.5	8.7	10	20
JNTMBG□□7R50AZ	7.5	10.3	12	14	25
JNTMBG□□0010AZ	10	12.3	15	18	30
JNTMBG□□0015AZ	15	20.6	24	29	50
JNTMBG□□0020AZ	20	27.4	32	38	60
JNTMBG□□0025AZ	25	34	40	48	70
JNTMBG□□0030AZ	30	41	48	53	80
JNTMBG□□0040AZ	40	54	64	70	100
JNTMBG□□0050AZ	50	68	80	88	125
JNTMBG□□0060AZ	60	82	96	106	150
JNTMBG□□0075AZ	75	110	128	141	200

Fuse Type UL designated SEMICONDUCTOR PROTECTION FUSES

Class CC,J,T,RK1 or RK5

Voltage Range: 300V for drives with 230V class VFD

500V for drives with 460V class VFD

## 2. Using LCD Digital Operator

### ■ Functions of LCD digital operator

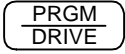
JNEP-36 LCD digital operator has 2 modes: DRIVE mode and PRGM mode. When the inverter is stopped, DRIVE mode or PRGM mode can be selected by pressing the key . In DRIVE mode, the operation is enabled. Instead, in the PRGM mode, the parameter settings for operation can be changed but the operation is not enabled. The component names and function are shown as below:

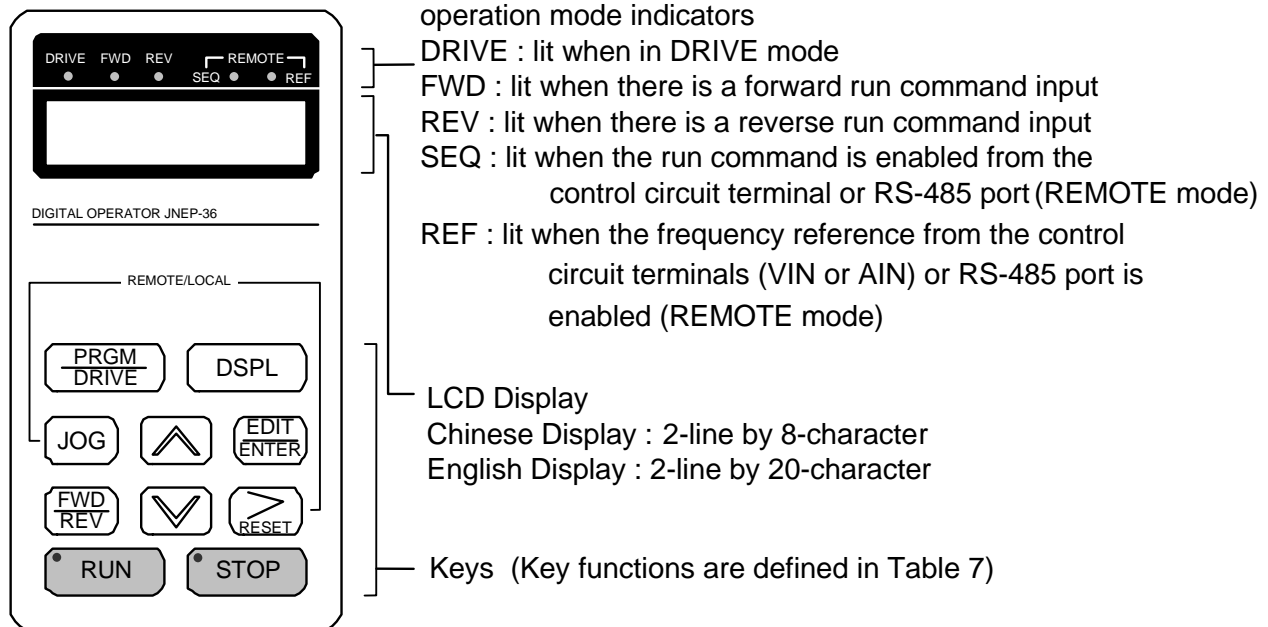











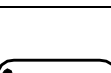

Fig. 8. LCD Digital operator

- Remote/Local switch function:
  - Local mode – RUN command input from LCD Digital Operator (SEQ LED off)
    - Frequency command input from LCD Digital Operator (REF LED off)
  - Remote mode – RUN command input from control circuit (when Sn-04=1) or RS-485 comm. port (when Sn-04=2) (SEQ LED lit)
    - Frequency command input from control circuit (when Sn-05=1) or RS-485 comm. port (when Sn-05=2) (REF LED lit)
- Press  and  both to switch Local/Remote mode. (Switching action of Local/Remote only can be done while Inverter stop.)

**Table 7 Key's functions**

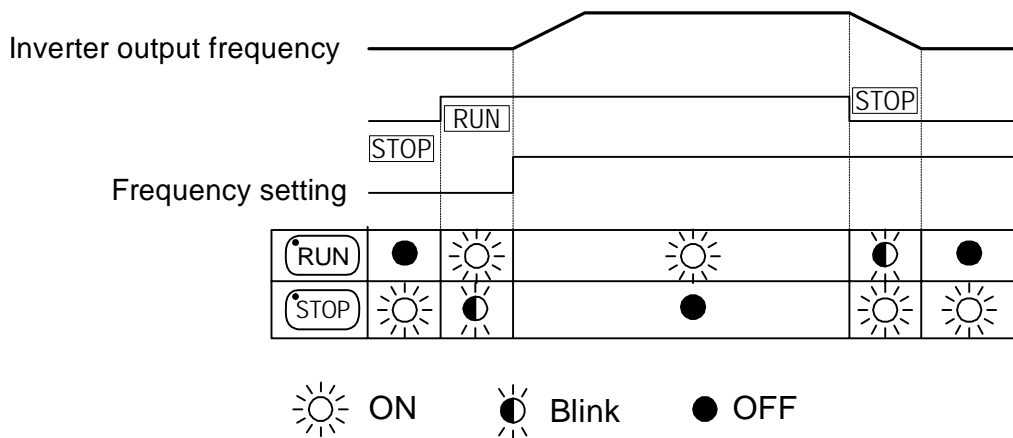

Key	Name	Function
	PRGM/DRIVE key	Switches over between program mode (PRGM) and drive mode (DRIVE).
	DSPL key	Display operation status
	JOG key	Enable jog operation from LCD digital operator in operation (DRIVE).
	FWD/REV key	Select the rotation direction from LCD digital operator.
	RESET key	Set the number of digital for user constant settings. Also It acts as the reset key when a fault has occurred.
	INCREMENT key	Select the menu items, groups, functions, and user constant name, and increment set values.
	DECREMENT key	Select the menu items, groups, functions, and user constant name, and decrement set values.
	EDIT/ENTER key	Select the menu items, groups, functions, and user constants name, and set values (EDIT). After finishing the above action, press the key (ENTER).
	RUN key	Start inverter operation in (DRIVE) mode when the digital operator is used. The LED will light.
	STOP key	Stop inverter operation from LCD digital operator. The STOP key can be enabled or disabled by setting the parameter Sn-07 when operating from the control circuit terminal.

RUN , STOP indicator lights or blinks to indicate the 3 operating status:



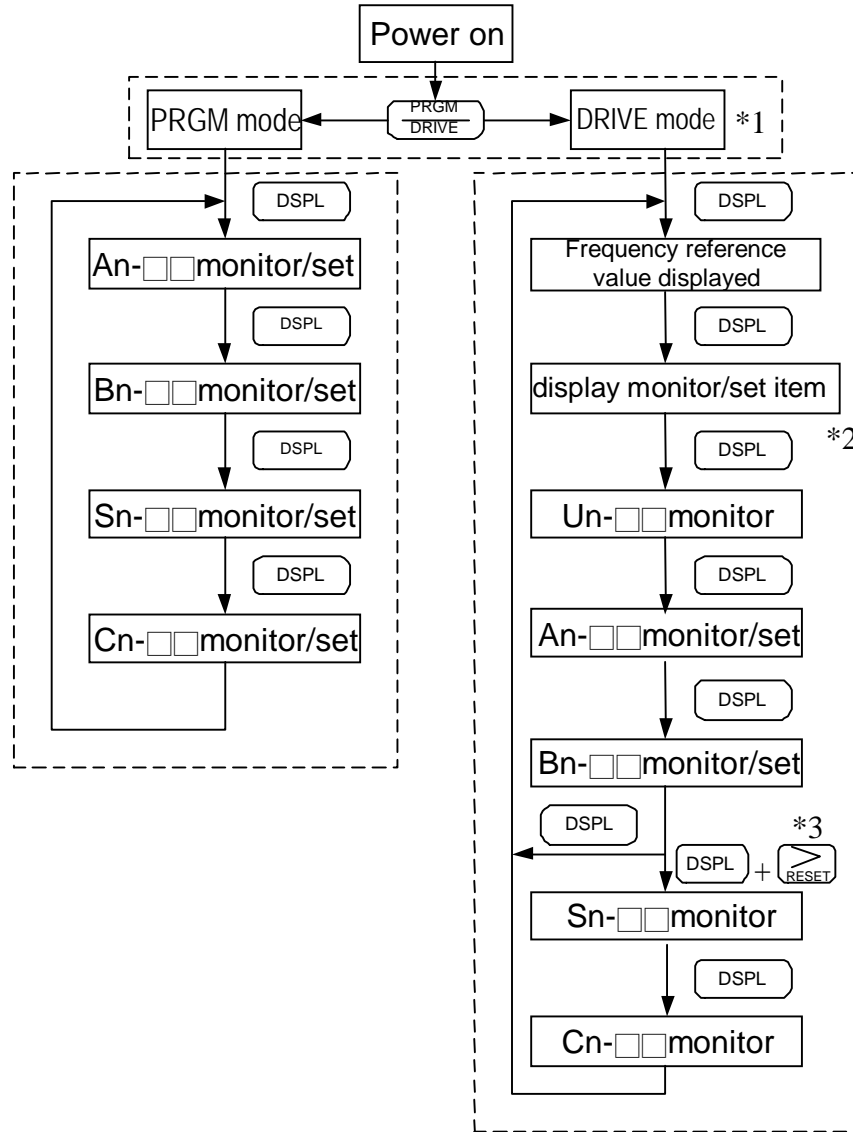

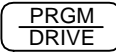
■ Display contents in DRIVE mode and PRGM mode



\*1 When the inverter is powered up, the inverter system immediately enters into DRIVE mode. Press the  key, the system will switch into PRGM mode. If the fault occurs, press the  key and enter into DRIVE mode to monitor the corresponding Un-□□ contents. If a fault occurs in the DRIVE mode, the corresponding fault will be displayed. Press the  key and reset the fault.

\*2 The monitored items will be displayed according to the settings of Bn-12 and Bn-13.

\*3 When in the DRIVE mode, press the  key and  key, the setting values of Sn- and Cn-□□ will only be displayed for monitoring but not for changing or setting.

## ■ Parameter description

The inverter has 4 groups of user parameters:

Parameters	Description
An-□□	Frequency command
Bn-□□	Parameter groups can be changed during running
Sn-□□	System parameter groups (can be changes only after stop)
Cn-□□	Control parameter groups (can be changed only after stop)

The parameter setting of Sn-03 (operation status) will determine if the setting value of different parameter groups are allowed to be changed or only to be monitored, as shown below:

Sn-03	DRIVE mode		PRGM mode	
	To be set	To be monitored	To be set	To be monitored
0 <sup>*1</sup>	An,Bn	Sn,Cn	An,Bn,Sn,Cn	–
1	An	Bn,(Sn,Cn) <sup>*2</sup>	An	Bn,Sn,Cn

\*1 : Factory setting

\*2 : When in DRIVE mode, the parameter group Sn-, Cn- can only be monitored if the



key and the key are to be pressed simultaneously.

\*3 : After a few trial and adjustment, the setting value Sn-03 is set to be “1” so as not be modified again.

## ■ Example of using LCD digital operator

Note :

Before operation: Control parameter Cn-01 value must be set as the input AC voltage value. For example, Cn-01=380 if AC input voltage is 380.

This example will explain the operating of the inverter according to the following time chart.

## ■ OPERATION MODE

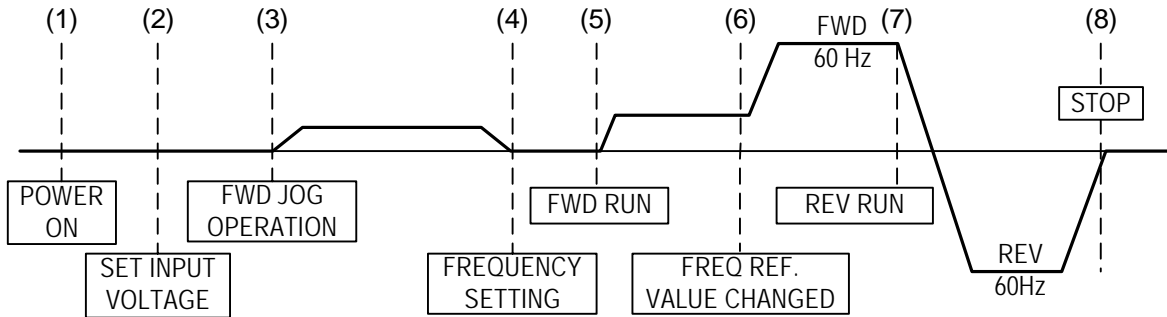







## ■ Example of operation

Description	Key Sequence	Digital Operator Display	Remark
<p>(1) When Power on</p> <ul style="list-style-type: none"> <li>• Select frequency reference value displayed</li> <li>• Select PRGM mode</li> </ul> <p>(2) Input voltage setting (e.g. AC input voltage is 380V)</p> <ul style="list-style-type: none"> <li>• Select CONTROL PARAMETER</li> <li>• Display Cn-01 setting</li> <li>• Input Voltage 380V</li> </ul> <p>(continued)</p>	<p>PRGM DRIVE</p> <p>DSPL press 3 times</p> <p>EDIT ENTER</p> <p>RESET ↑ ↓</p> <p>EDIT ENTER</p>	<p>Freq. Cmd. 000.00Hz TECO</p> <p>An -01 Freq. Cmd. 1</p> <p>Cn -01- Input Voltage</p> <p>Cn-01 = 440.0V Input Voltage</p> <p>Cn-01 = 380.0V Input Voltage</p> <p>Entry Accepted</p>	<p>LED DRIVE OFF</p> <p>Display for 0.5 sec</p>

Description	Key Sequence	Digital Operator Display	Remark
(continued)			
<p>(3) FWD JOG</p> <ul style="list-style-type: none"> <li>Select DRIVE mode</li> <li>Select output frequency displayed</li> <li>Select direction of rotation (When power on, initially defaulted FWD)</li> <li>Jog operation</li> </ul>	<p>PRGM DRIVE</p> <p>DSPL</p> <p>JOG</p>	<p>Freq. Cmd.000.00Hz TECO</p> <p>Freq. Cmd.0.00 Hz O/P Freq. 0.00 Hz</p> <p>O/P Freq. 6.00 Hz Freq. Cmd. 6.00 Hz</p>	<p>LED ON <b>DRIVE</b></p> <p>LED ON <b>FWD</b></p>
<p>(4) Frequency setting</p> <p>15 Hz</p> <ul style="list-style-type: none"> <li>Select frequency cmd displayed</li> <li>Change frequency cmd</li> <li>Set new frequency cmd</li> </ul>	<p>DSPL press 4 times</p> <p>RESET ↑ ↓</p> <p>EDIT ENTER</p> <p>DSPL</p>	<p>Freq. Cmd.000.00Hz TECO</p> <p>Freq. Cmd.015.00Hz TECO</p> <p>Freq. Cmd.015.00Hz TECO</p> <p>Entry Accepted</p> <p>O/P Freq. 0.00 Hz Freq. Cmd. 15.00 Hz</p>	<p>Displayed for 0.5sec Confirm the display.</p>
<p>(5) FWD run</p> <ul style="list-style-type: none"> <li>Select O/P frequency displayed</li> <li>Running operation</li> </ul>	<p>DSPL</p> <p>• RUN</p>	<p>O/P Freq. 15.00 Hz Freq. Cmd. 15.00 Hz</p>	<p>LED ON <b>• RUN</b></p>
<p>(6) Frequency command change</p> <p>60 Hz</p> <ul style="list-style-type: none"> <li>Select frequency cmd displayed</li> <li>Change reference value</li> <li>Enter new frequency cmd setting</li> </ul>	<p>DSPL press 4 times</p> <p>RESET ↑ ↓</p> <p>EDIT ENTER</p> <p>DSPL</p>	<p>Freq. Cmd.015.00Hz TECO</p> <p>Freq. Cmd.060.00Hz TECO</p> <p>Freq. Cmd.060.00Hz TECO</p> <p>Entry Accepted</p> <p>O/P Freq. 60.00 Hz Freq. Cmd. 60.00 Hz</p>	<p>Displayed for 0.5sec Confirm the display.</p>
<p>(7) REV RUN</p> <ul style="list-style-type: none"> <li>Select frequency cmd displayed</li> <li>Change to REV</li> </ul>	<p>DSPL</p> <p>FWD REV</p>	<p>O/P Freq. 60.00 Hz Freq. Cmd. 60.00 Hz</p>	<p>LED ON <b>REV</b></p>
<p>(8) STOP</p> <ul style="list-style-type: none"> <li>Decrement to STOP</li> </ul>	<p>• STOP</p>	<p>O/P Freq. 0.00 Hz Freq. Cmd. 60.00 Hz</p>	<p>LED ON <b>• STOP</b></p> <p>(Blinking while decel.) <b>• RUN</b></p>

■ Example of display (use  and  keys to display monitored items/contents)

Description	Key Sequence	Digital Operator Display	Remark
• Display Frequency Command		Freq. Cmd. 60.00Hz TECO	
• Display Monitor Contents *1		Freq. Cmd. 60.00 Hz O/P Freq. 60.00 Hz	
• Display Output Current		Freq. Cmd. 60.00 Hz O/P I 12.5 A	
• Display Output Voltage		Freq. Cmd. 60.00 Hz O/P Volt. 220.0 V	
• Display DC Voltage		Freq. Cmd. 60.00 Hz DC Volt. 310.0 V	
• Display Output Voltage		Freq. Cmd. 60.00 Hz O/P Volt. 220.0 V	
• Display Output Current		Freq. Cmd. 60.00 Hz O/P I 12.5 A	

\*1. The monitor contents can be selected by the setting of Bn-12 and Bn-13

### 3. Parameter Setting

#### 3.1 Frequency command (in Multi-speed operation) An\*1-□□

Under the DRIVE mode, the user can monitor the parameters and set their values.

Parameter No.	Name	LCD Display (English)	Setting Range	Setting <sup>*2</sup> Unit	Factory Setting	Ref. Page
An-01	Frequency Command 1	An-01= 000.00Hz Freq. Cmd. 1	0.00~400.00Hz	0.01Hz	0.00Hz	3-54 3-70 3-71
An-02	Frequency Command 2	An-02= 000.00Hz Freq. Cmd. 2	0.00~400.00Hz	0.01Hz	0.00Hz	
An-03	Frequency Command 3	An-03= 000.00Hz Freq. Cmd. 3	0.00~400.00Hz	0.01Hz	0.00Hz	
An-04	Frequency Command 4	An-04= 000.00Hz Freq. Cmd. 4	0.00~400.00Hz	0.01Hz	0.00Hz	
An-05	Frequency Command 5	An-05= 000.00Hz Freq. Cmd. 5	0.00~400.00Hz	0.01Hz	0.00Hz	
An-06	Frequency Command 6	An-06= 000.00Hz Freq. Cmd. 6	0.00~400.00Hz	0.01Hz	0.00Hz	
An-07	Frequency Command 7	An-07= 000.00Hz Freq. Cmd. 7	0.00~400.00Hz	0.01Hz	0.00Hz	
An-08	Frequency Command 8	An-08= 000.00Hz Freq. Cmd. 8	0.00~400.00Hz	0.01Hz	0.00Hz	
An-09	Frequency Command 9	An-09= 000.00Hz Freq. Cmd. 9	0.00~400.00Hz	0.01Hz	0.00Hz	
An-10	Frequency Command 10	An-10= 000.00Hz Freq. Cmd. 10	0.00~400.00Hz	0.01Hz	0.00Hz	
An-11	Frequency Command 11	An-11= 000.00Hz Freq. Cmd. 11	0.00~400.00Hz	0.01Hz	0.00Hz	
An-12	Frequency Command 12	An-12= 000.00Hz Freq. Cmd. 12	0.00~400.00Hz	0.01Hz	0.00Hz	
An-13	Frequency Command 13	An-13= 000.00Hz Freq. Cmd. 13	0.00~400.00Hz	0.01Hz	0.00Hz	
An-14	Frequency Command 14	An-14= 000.00Hz Freq. Cmd. 14	0.00~400.00Hz	0.01Hz	0.00Hz	
An-15	Frequency Command 15	An-15= 000.00Hz Freq. Cmd. 15	0.00~400.00Hz	0.01Hz	0.00Hz	
An-16	Frequency Command 16	An-16= 000.00Hz Freq. Cmd. 16	0.00~400.00Hz	0.01Hz	0.00Hz	
An-17	Jog Frequency Command	An-17= 000.00Hz Jog Freq. Cmd.	0.00~400.00Hz	0.01Hz	6.00Hz	3-56

\*1. At factory setting, the value of “Setting Unit” is 0.01Hz.

\*2. The displayed “Setting Unit” can be changed through the parameter Cn-28.

### 3.2 Parameters Groups Can Be Changed during Running Bn-□□

Under the DRIVE mode, the Parameter group can be monitored and set by the users.

Function	Parameter No.	Name	LCD display (English)	Setting range	Setting Unit	Factory Setting	Ref. Page
Acc/Dec time	Bn-01	Acceleration Time 1	Bn-01= 0010.0s Acc. Time 1	0.0~6000.0s	0.1s	10.0s	3-4
	Bn-02	Deceleration Time 1	Bn-02= 0010.0s Dec. Time 1	0.0~6000.0s	0.1s	10.0s	
	Bn-03	Acceleration Time 2	Bn-03= 0010.0s Acc. Time 2	0.0~6000.0s	0.1s	10.0s	
	Bn-04	Deceleration Time 2	Bn-04= 0010.0s Dec. Time 2	0.0~6000.0s	0.1s	10.0s	
Analog Frequency	Bn-05	Analog Frequency Cmd. Gain (Voltage)	Bn-05= 0100.0% Voltage Cmd. Gain	0.0~1000.0%	0.10%	100.00%	3-5
	Bn-06	Analog Frequency Cmd. Bias (Voltage)	Bn-06= 000.0% Voltage Cmd. Bias	-100.0%~100.0%	0.10%	0.00%	
	Bn-07	Analog Frequency Cmd Gain. (Current)	Bn-07= 0100.0% Current Cmd. Gain	0.0~1000.0%	0.10%	100.00%	
	Bn-08	Analog Frequency Cmd Bias (Current)	Bn-08= 000.0% Current Cmd. Bias	-100.0%~100.0%	0.10%	0.00%	
Multi-Function Analog Input	Bn-09	Multi-Function Analog Input Gain	Bn-09= 0100.0% Multi_Fun. ~Gain	0.0~1000.0%	0.10%	100.00%	3-5
	Bn-10	Multi-Function Analog Input Bias	Bn-10= 000.0% Multi_Fun. ~Bias	-100.0%~100.0%	0.10%	0.00%	
Torque Boost	Bn-11	Auto Torque Boost Gain	Bn-11= 0.5 Auto_Boost Gain	0.0~2.0	0.1	0.5	3-5
Monitor	Bn-12	Monitor 1	Bn-12= 01 Display: Freq.Cmd.	1~18	1	1	3-6
	Bn-13	Monitor 2	Bn-13= 02 Display: O/P Freq.	1~18	1	2	
Multi-Function Analog Output	Bn-14	Multi-Function Analog Output AO1 Gain	Bn-14= 1.00 ~Output AO1 Gain	0.01~2.55	0.01	1	3-7
	Bn-15	Multi-Function Analog Output AO2 Gain	Bn-15= 1.00 ~Output AO2 Gain	0.01~2.55	0.01	1	
PID Control	Bn-16	PID Detection Gain	Bn-16= 01.00 PID Cmd. Gain	0.01~10.00	0.01	1	3-7
	Bn-17	PID Proportional Gain	Bn-17= 01.00 PID P_gain	0.01~10.00	0.01	1	
	Bn-18	PID integral time	Bn-18= 10.00s PID I_Time	0.00~100.00s	0.01s	10.00s	
	Bn-19	PID Differential Time	Bn-19= 0.00s PID D_Time	0~1.00s	0.01s	0.00s	
	Bn-20	PID Bias	Bn-20= 0% PID Bias	0~109%	1%	0%	

Function	Parameter No.	Name	LCD display (English)	Setting range	Setting Unit	Factory Setting	Ref. Page
Auto_Run Time Function	Bn-21	1st_Step Time Under Auto_Run Mode	Bn-21= 0000.0s Time 1	0.0~6000.0s	0.1s	0.0s	3-70 3-71
	Bn-22	2nd_Step Time Under Auto_Run Mode	Bn-22= 0000.0s Time 2	0.0~6000.0s	0.1s	0.0s	
	Bn-23	3rd_Step Time Under Auto_Run Mode	Bn-23= 0000.0s Time 3	0.0~6000.0s	0.1s	0.0s	
	Bn-24	4th_Step Time Under Auto_Run Mode	Bn-24= 0000.0s Time 4	0.0~6000.0s	0.1s	0.0s	
	Bn-25	5th_Step Time Under Auto_Run Mode	Bn-25= 0000.0s Time 5	0.0~6000.0s	0.1s	0.0s	
	Bn-26	6th_Step Time Under Auto_Run Mode	Bn-26= 0000.0s Time 6	0.0~6000.0s	0.1s	0.0s	
	Bn-27	7th_Step Time Under Auto_Run Mode	Bn-27= 0000.0s Time 7	0.0~6000.0s	0.1s	0.0s	
	Bn-28	8th_Step Time Under Auto_Run Mode	Bn-28= 0000.0s Time 8	0.0~6000.0s	0.1s	0.0s	
	Bn-29	9th_Step Time Under Auto_Run Mode	Bn-29= 0000.0s Time 9	0.0~6000.0s	0.1s	0.0s	
	Bn-30	10th_Step Time Under Auto_Run Mode	Bn-30= 0000.0s Time 10	0.0~6000.0s	0.1s	0.0s	
	Bn-31	11th_Step Time Under Auto_Run Mode	Bn-31= 0000.0s Time 11	0.0~6000.0s	0.1s	0.0s	
	Bn-32	12th_Step Time Under Auto_Run Mode	Bn-32= 0000.0s Time 12	0.0~6000.0s	0.1s	0.0s	
	Bn-33	13th_Step Time Under Auto_Run Mode	Bn-33= 0000.0s Time 13	0.0~6000.0s	0.1s	0.0s	
	Bn-34	14th_Step Time Under Auto_Run Mode	Bn-34= 0000.0s Time 14	0.0~6000.0s	0.1s	0.0s	
	Bn-35	15th_Step Time Under Auto_Run Mode	Bn-35= 0000.0s Time 15	0.0~6000.0s	0.1s	0.0s	
	Bn-36	16th_Step Time Under Auto_Run Mode	Bn-36= 0000.0s Time 16	0.0~6000.0s	0.1s	0.0s	
Timer Function	Bn-37	Timer Function On_Delay Time	Bn-37= 0000.0s ON_delay Setting	0.0~6000.0s	0.1s	0.0s	3-9
	Bn-38	Timer Function Off_Delay Time	Bn-38= 0000.0s OFF_delay Setting	0.0~6000.0s	0.1s	0.0s	
Energy Saving	Bn-39	Energy_Saving Gain	Bn-39= 100% Eg.Saving Gain	50~150%	1%	100%	3-10
Monitor	Bn-40	Monitor 3	Bn-40=00 Display : Set_Freq.	00~18	1	0	3-10

Function	Parameter No.	Name	LCD display (English)	Setting range	Setting Unit	Factory Setting	Ref. Page
Pulse Input	Bn-41	Pulse Input Upper Limit	Bn-41=1440 Hz Pulse_Mul_Up_Bound	1440~32000	1 Hz	1440	3-11
	Bn-42	Pulse Input Gain	Bn-41=100.0 % Pulse_Mul_Gain	0.0~1000.0	0.10%	100	
	Bn-43	Pulse Input Bias	Bn-41=000.0 % Pulse_Mul_Bias	-100.0~100.0	0.1Hz	0	
	Bn-44	Pulse Input Delay Time	Bn-41=0.10 s Pulse_Mul_Filter	0.00~2.00	0.01s	0.1	
PID Feedback Display	Bn-45*1	PID Feedback Display at 0%	Bn-45= 0000 PID Display at 0%	1~9999*1	1*2	0	3-11
	Bn-46*1	PID Feedback Display at 100%	Bn-46= 1000 PID Display at 0%	1~9999*1	1*2	1000	

\*1. These parameters are available for 74.03 and later software version only.

\*2. The displayed “Setting Unit” and “Setting Range” can be changed through parameter Cn-28 and Sn-70.

- (1) Acceleration Time 1 (Bn-01)
- (2) Deceleration Time 1 (Bn-02)
- (3) Acceleration Time 2 (Bn-03)
- (4) Deceleration Time 2 (Bn-04)

- Set individual Acceleration/Deceleration times
- Acceleration time: the time required to go from 0% to 100% of the maximum output frequency
- Deceleration time: the time required to go from 100% to 0% of the maximum output frequency
- If the acceleration/deceleration time sectors 1 and 2 are input via the multi-function inputs terminal ⑤~⑧, the acceleration/Deceleration can be switched between 2 sectors even in the running status.

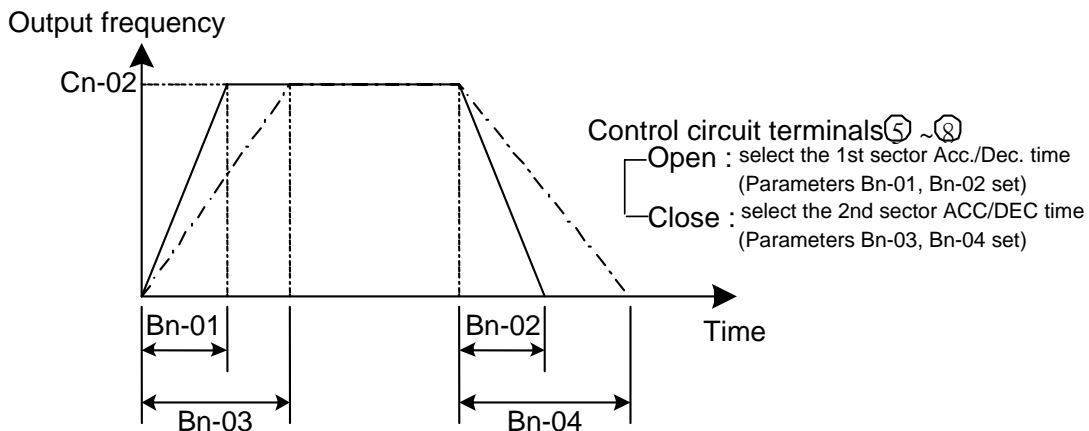

Fig. 9. Acceleration and Deceleration time

Note :

1. To set the S-curve characteristics function, please refer to the description of Cn-41~Cn-44.
2. The S-curve characteristic times can be set respectively for beginning-accel. end-accel., beginning-decel., and end-decel. through the parameters setting of Cn-41 ~ Cn-44.

- (5) Analog Frequency Command Gain (Voltage) (Bn-05)
  - (6) Analog Frequency Command Bias (Voltage) (Bn-06)
  - (7) Analog Frequency Command Gain (Current) (Bn-07)
  - (8) Analog Frequency Command Bias (Current) (Bn-08)
  - (9) Multi-function Analog Input Gain (Bn-09)
  - (10) Multi-function Analog Input Bias (Bn-10)
- For every different analog frequency command (voltage or current) and multi-function analog inputs, their corresponding gain and bias should be specified respectively.

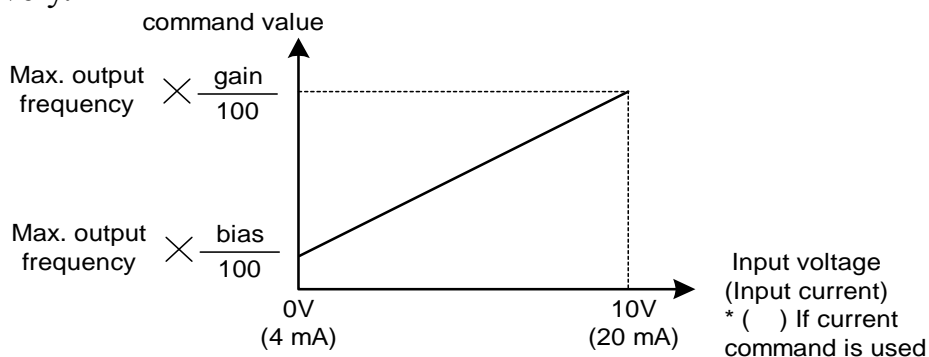

Fig. 10. Analog input gain and bias

- (11) Auto Torque Boost Gain (Bn-11)
- The inverter can increase the output torque to compensate the load increase automatically through the auto torque boost function. Then the output voltage will increase. As a result, the fault trip cases can be decreased. The energy efficiency is also improved. In the case that the wiring distance between the inverter and the motor is too long (e.g. more than 100m), the motor torque is a little short because of voltage drop. Increase the value of Bn-11 gradually and make sure the current will not increase too much. Normally, no adjustment is required.

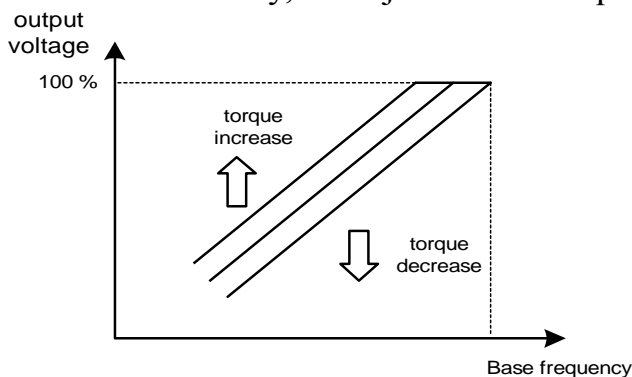

Fig. 11. Adjust the auto torque boost gain Bn-11 to increase the output torque.

- If the driven motor capacity is less than the inverter capacity (Max. applicable motor capacity), raise the setting.
- If the motor generates excessive oscillation, lower the setting.

(12) Monitor 1 (Bn-12)

(13) Monitor 2 (Bn-13)

- In the DRIVE mode, 2 inverter input/output statuses can be monitored at the same time. The specified items can be set through the setting of Bn-12 and Bn-13. For more details, refer to Table 8.

• Example:

(1) Bn-12= 02 Display Bn-13= 01	O/P Freq. 15.00Hz Freq.Cmd. 15.00Hz
(2) Bn-12= 03 Display Bn-13= 05	O/P I 21.0A DC Volt 311V
(3) Bn-12= 11 Display Bn-13= 12	I/P Term. 00101010 O/P Term. 00010010



Note : While monitoring, use the  or  key to show the next lower-row displayed. But the setting of Bn-12 and Bn-13 does not change.

Table 8 Setting of Monitoring contents

Setting	Monitoring contents	Setting	Monitoring contents
Bn-12= 01	Freq.Cmd.	Bn-13= 01	Freq.Cmd.
Bn-12= 02	O/P Freq.	Bn-13= 02	O/P Freq.
Bn-12= 03	O/P I	Bn-13= 03	O/P I
Bn-12= 04	O/P V	Bn-13= 04	O/P V
Bn-12= 05	DC Volt	Bn-13= 05	DC Volt
Bn-12= 06	Term. VIN	Bn-13= 06	Term. VIN
Bn-12= 07	Term. AIN	Bn-13= 07	Term. AIN
Bn-12= 08	Term. AUX	Bn-13= 08	Term. AUX
Bn-12= 09	~ Output(AO1)	Bn-13= 09	~ Output(AO1)
Bn-12= 10	~ Output(AO2)	Bn-13= 10	~ Output(AO1)
Bn-12= 11	I/P Term	Bn-13= 11	I/P Term
Bn-12= 12	O/P Term	Bn-13= 12	O/P Term
Bn-12= 13	Sp. FBK	Bn-13= 13	Sp. FBK
Bn-12= 14	Sp. Compen.	Bn-13= 14	Sp. Compen.
Bn-12= 15	PID I/P	Bn-13= 15	PID I/P
Bn-12= 16	PID O/P(Un-16)	Bn-13= 16	PID O/P(Un-16)
Bn-12= 17	PID O/P(Un-17)	Bn-13= 17	PID O/P(Un-17)
Bn-12= 18	Motor Sp.	Bn-13= 18	Motor Sp.

(14) Multi-function Analog Output AO1 Gain (Bn-14)

(15) Multi-function Analog Output AO1 Gain (Bn-15)

- Multi-function analog output AO1 and AO2 can be set for their individual voltage level respectively.

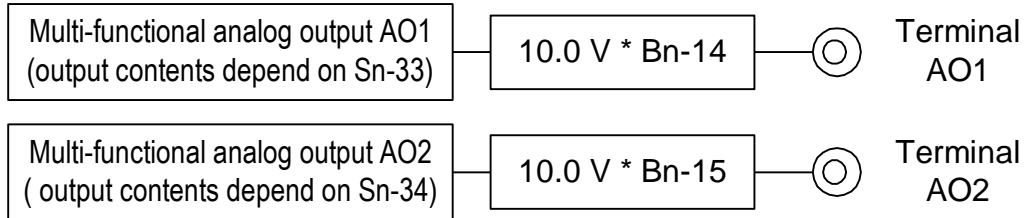

(16) PID Detection Gain (Bn-16)

(17) PID Proportional Gain (Bn-17)

(18) PID Integral Time (Bn-18)

(19) PID Differential Time (Bn-19)

(20) PID Bias (Bn-20)

- The PID control function is a control system that matches a feedback value (i.e., a detected value) to the set target value. Combining the proportional (P), integral (I) and derivative (D) control make the control possible to achieve required response with the constant setting and tuning procedure of proportional gain Bn-17, integral time Bn-18 and derivative time Bn-19.
- See the appendix on page App.1 for “PID Parameter Setting”.
- Fig. 12 is a Block diagram of the inverter’s internal PID control.
- If both the target value and feedback value are set to 0, adjust the inverter output frequency to zero.

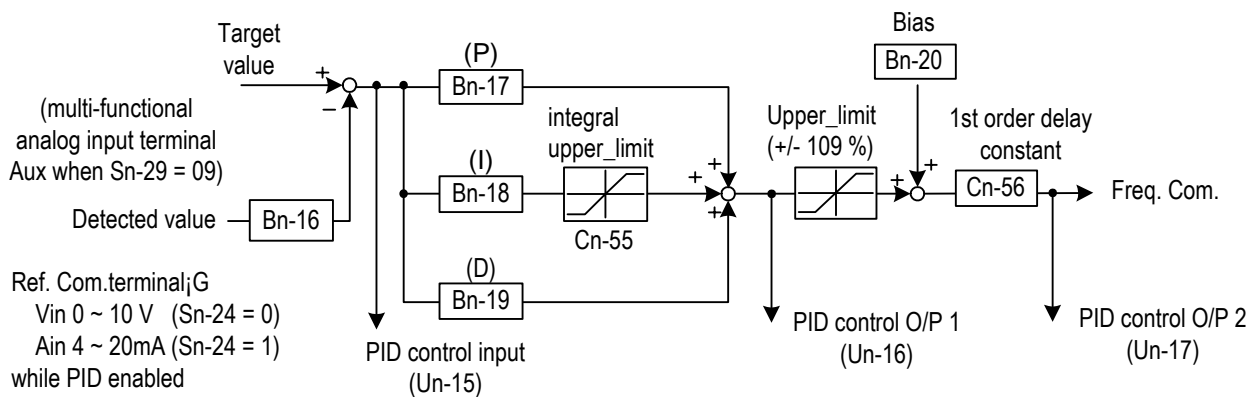

Fig. 12. Block diagram for PID control in inverter  
(For the version before 30.17)

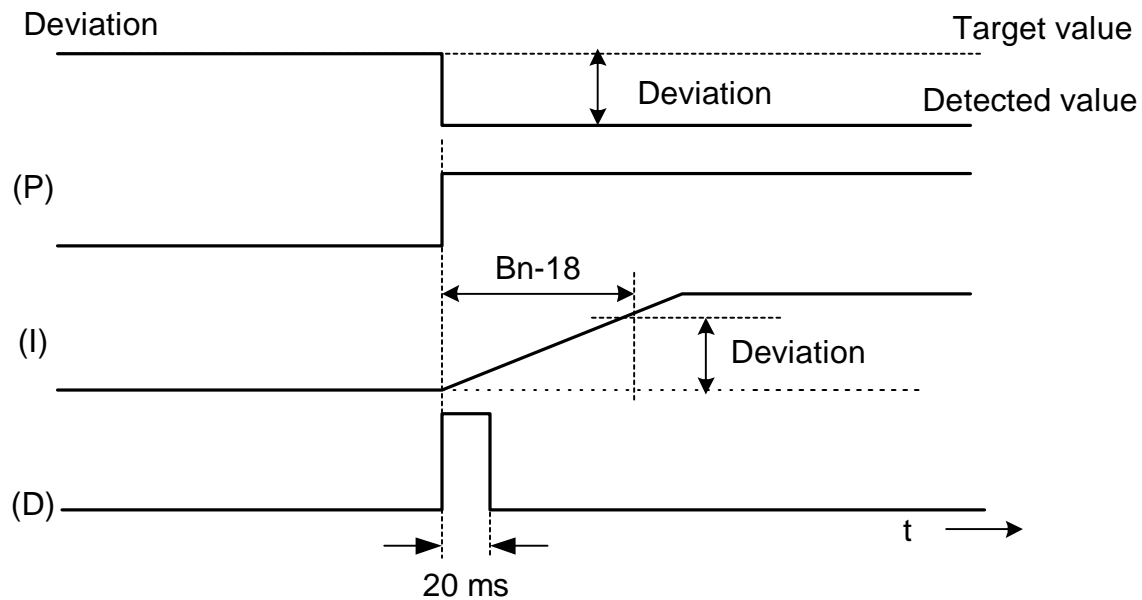

Fig. 13. Response of PID control for step-shape (deviation) input

- Deviation = Target value – Detected value  $\times$  Bn-16.
- P's control output = deviation  $\times$  Bn-17.
- I's control output will increase with time and the output will be equal to the deviation after time specified by parameter Bn-18

The parameter Cn-55 will prevent the calculated value of the integral control (with the integral time Bn-18) in the PID control from exceeding the fixed amount.

$$\square \text{D's control output} = \text{difference} \times \left( \frac{\text{Bn-19}}{5 \text{ m sec}} \right)$$

Note: The enable PID function, parameter Sn-64 must be set to 1

30.18 newly revised version inverter develops 8 PID control modes as following description:

0: Unavailable

1: (Positive characteristic) input of differential controller is balance of feedback value and frequency value.

2: (Positive characteristic) input of differential controller is feedback value

3: (Positive characteristic) refers to frequency and PID control output. Input of differential controller is balance of feedback value and frequency value.

4: (Positive characteristic) refers to frequency and PID control output. Input of differential controller is feedback value

5: (Negative characteristic) input of differential controller is balance of feedback value and frequency value.

6: (Negative characteristic) input of differential controller is feedback value

7: (Negative characteristic) refers to frequency and PID control output. Input of differential controller is balance of feedback value and frequency value.

8: (Negative characteristic) refers to frequency and PID control output. Input of differential controller is feedback value.

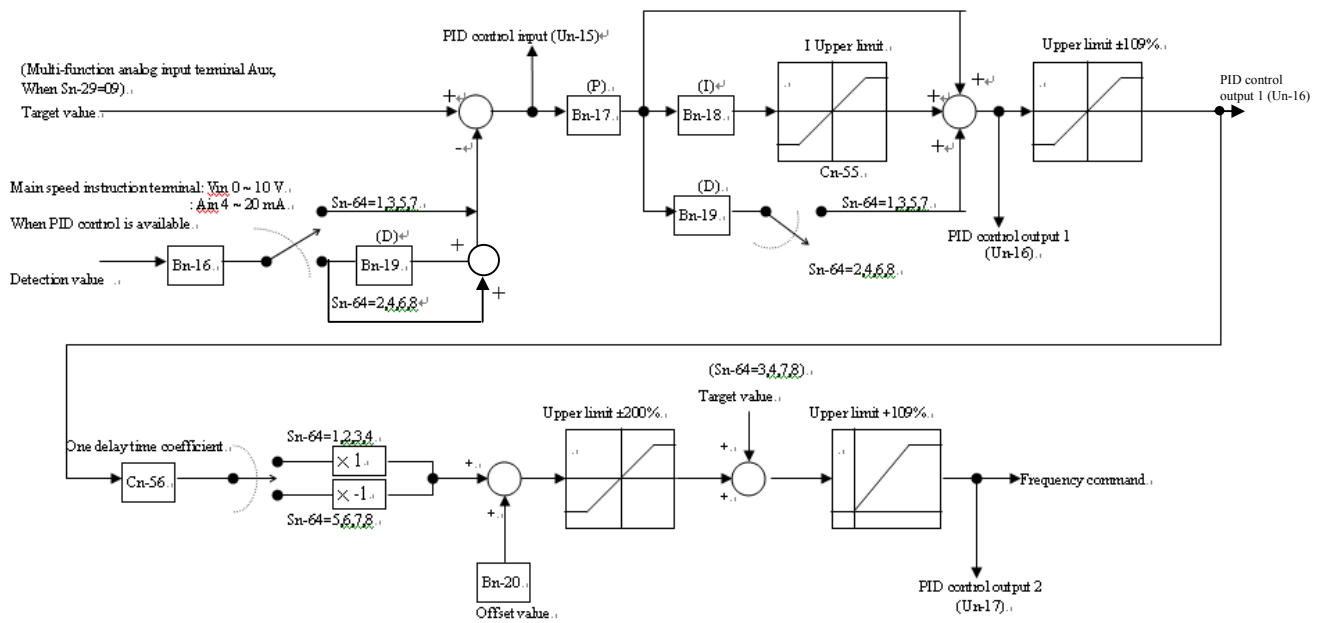

Fig. 14. PID Control Block diagram (After Version 30.18)

### (21) Time Setting in Auto\_Run Mode (Bn-21 ~ Bn-36)

- In Auto\_Run mode, the time setting for individual step is described on “(Sn-44~60) auto run mode selection and enable”.

### (22) Timer ON\_Delay Time (Bn-37)

### (23) Timer OFF\_Delay Time (Bn-38)

- The timer function is enabled when the timer function input setting (Sn-25~28=19) and its timer function output setting (Sn-30~32=21) are set for the multi-function input and output respectively.
- These inputs and outputs serve as general-purpose I/O. Setting ON/OFF delay time (Bn-37/38) for the timer can prevent chattering of sensors, switches and so on.
- When the timer function input ON times is longer than the value set for Bn-37, the timer function output turns ON.
- When the timer function input OFF time is longer than the value set for Bn-38, the timer function output turns OFF. An example is shown below.

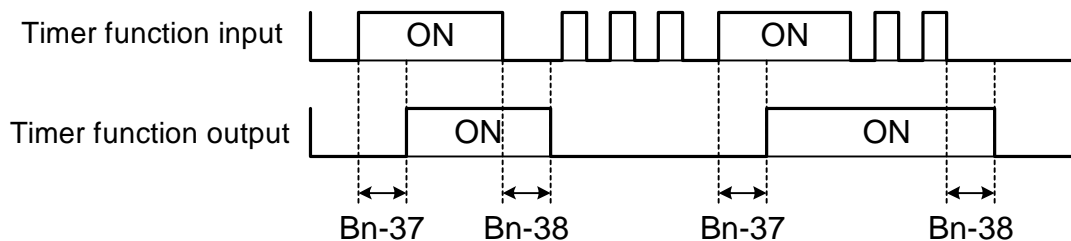

Fig. 15. An operation example of timer function

(24) Energy Saving Gain (Bn-39)

- Input the energy saving command while a light load causes the inverter output voltage to be reduced and save energy. Set this value as a percentage of the V/F pattern. The setting range is 50~150%. The factory setting is 100% and the energy saving function is disabled. If the energy saving gain Bn-39 is not 100%, the energy saving function is enabled.
- In energy saving mode (Bn-39 ≠ 100), the output voltage will automatically decrease and be proportional to energy saving gain Bn-39. The Bn-39 setting should not be small so that the motor will not stall.
- The energy saving function is disabled in the PID close-loop control and during acceleration and deceleration.

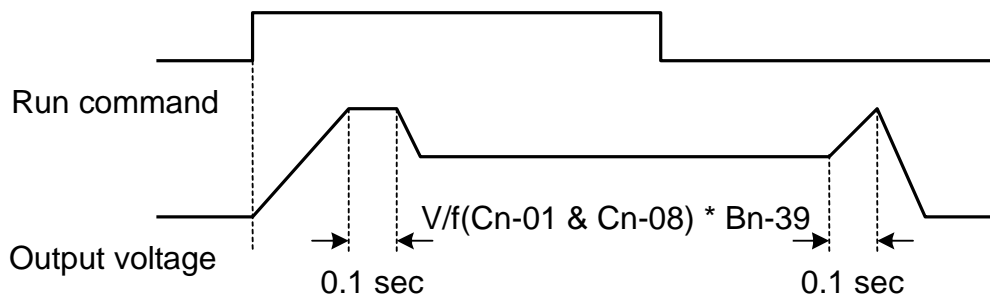

Fig. 16. Time chart for energy-saving operation

(25) Monitor 3 (Bn-40)

- The parameter sets immediate display content as power on.
- When Bn-40 = 00, inverter power on, the first line will display frequency command, while the second line will display characters “TECO” as following diagram:

Freq . Cmd. : 15.00 Hz
TECO

- When Bn-40 ≠ 00, that is Bn-40=01~18, LCD will display the set monitor items while inverter power on. The first line display content is determined by Bn-12. The second line is determined by Bn-40 as following diagram:

Set Bn-12=01  
Bn-40=02

<b>Freq . Cmd. :</b>	<b>15.00 Hz</b>
<b>O / P Freq.:</b>	<b>00.00 Hz</b>

- Bn-40=01~18 parameter description is same with Bn-12, Bn-13. Please refer to Table 1, Monitor item set.



### 3.3 Control Parameters Cn-□□

Function	Parameter No.	Name	LCD display (English)	Setting range	Setting Unit	Factory Setting	Ref. Page
V/F Pattern Setting	Cn-01	Input Voltage	Cn-01= 230.0V Input Voltage	150.0~255.0V <sup>*2</sup>	0.1V	230.0V <sup>*1</sup>	3-15
	Cn-02	Max. Output Frequency	Cn-02= 060.0Hz Max. O/P Freq.	50.0~400.0Hz	0.1Hz	60.0Hz	3-15
	Cn-03	Max. Output Voltage	Cn-03= 230.0Hz Max. Voltage	0.1~255.0V <sup>*2</sup>	0.1V	230.0V <sup>*1</sup>	
	Cn-04	Max. Voltage Frequency	Cn-04= 060.0Hz Max. Volt Frequency	0.1~400.0Hz	0.1Hz	60.0Hz	
	Cn-05	Middle Output Frequency	Cn-05= 003.0Hz Middle O/P Freq.	0.1~400.0Hz	0.1Hz	3.0Hz	
	Cn-06	Voltage At Middle Output Frequency	Cn-06= 014.9V Middle Voltage	0.1~255.0V <sup>*2</sup>	0.1V	15.5V <sup>*1</sup>	
	Cn-07	Min Output Frequency	Cn-07= 001.5Hz Min O/P Freq.	0.1~400.0Hz	0.1Hz	1.5Hz	
	Cn-08	Voltage At Min. Output Frequency	Cn-08= 007.9V Min. Voltage	0.1~255.0V <sup>*2</sup>	0.1V	8.2V <sup>*1</sup>	
Motor Parameter	Cn-09	Motor Rated Current	Cn-09= 0003.3A Motor Rated I	*3	0.1A	3.3A <sup>*4</sup>	3-15
	Cn-10	No Load Current Of Motor	Cn-10= 30% Motor No-Load I	0~99%	1%	30%	3-16
	Cn-11	Rated Slip Of Motor	Cn-11= 0.0% Motor Rated Slip	0~9.9%	0.10%	0.00%	
	Cn-12	Line-To-Line Resistance Of Motor	Cn-12= 05.732Ω Motor Line R	0~65.535Ω	0.001Ω	5.732 <sup>*4</sup>	3-17
	Cn-13	Torque Compensation Of Core Loss	Cn-13= 0064W Core Loss	0~65535W	1W	64 <sup>*4</sup>	
DC Braking Function	Cn-14	DC Injection Braking Starting Frequency	Cn-14= 01.5Hz C Braking Start F	0.1~10.0 Hz	0.1Hz	1.5Hz	3-17
	Cn-15	DC Braking Current	Cn-15= 050% DC Braking Current	0~100%	1%	50%	
	Cn-16	DC Injection Braking Time At Stop	Cn-16= 00.5s DC Braking Stop Time	0.0~25.5s	0.1s	0.5s	
	Cn-17	DC Injection Braking Time At Start	Cn-17= 00.0s DC Braking Start Time	0.0~25.5s	0.1s	0.0s	
Frequency Limit	Cn-18	Frequency Command Upper Bound	Cn-18= 100% Freq.Cmd. Up Bound	0~109%	1%	100%	3-18
	Cn-19	Frequency Command Lower Bound	Cn-19= 000% Freq. Cmd. Low Bound	0~109%	1%	0%	
Frequency Jump	Cn-20	Frequency Jump Point 1	Cn-20= 000.0Hz Freq. Jump 1	0.0~400.0Hz	0.1Hz	0.0Hz	3-18
	Cn-21	Frequency Jump Point 2	Cn-21= 000.0Hz Freq. Jump 2	0.0~400.0Hz	0.1Hz	0.0Hz	
	Cn-22	Frequency Jump Point 3	Cn-22= 000.0Hz Freq. Jump 3	0.0~400.0Hz	0.1Hz	0.0Hz	
	Cn-23	Jump Frequency Width	Cn-23= 01.0Hz Freq. Jump Width	0.0~25.5Hz	0.1Hz	1.0Hz	

Function	Parameter No.	Name	LCD display (English)	Setting range	Setting Unit	Factory Setting	Ref. Page
Retry Function	Cn-24	Number of Auto Restart Attempt	Cn-24= 00 Retry Times	0~10	1	0	3-19
Stall Prevention	Cn-25	Stall Prevention During Acceleration	Cn-25= 170% Acc. Stall	30~200%	1%	170%	3-20
	Cn-26	Stall Prevention During Running	Cn-26= 160% Run Stall	30~200%	1%	160%	
Comm. Fault detection	Cn-27	Communication Fault Detection Time	Cn-27=01.0s Comm. Flt Det. Time	0.1~25.5s	0.1s	1s	3-20
Display Unit	Cn-28	LCD Digital Operator Display Unit	Cn-28= 00000 Operator Disp. Unit	0-39999	1	0	3-21
Frequency Agree Detection	Cn-29	Freq. Agree Detection Level During Accel.	Cn-29= 000.0Hz Acc. Freq. Det.Level	0.0~400.0Hz	0.1Hz	0.0Hz	3-22
	Cn-30	Freq. Agree Detection Level During Decel.	Cn-30= 000.0Hz Dec. Freq. Det. Level	0.0~400.0Hz	0.1Hz	0.0Hz	
	Cn-31	Frequency Agree Detection Width	Cn-31= 02.0Hz F Agree Det. Width	0.1~25.5Hz	0.1Hz	2.0Hz	
Torque Detection 1	Cn-32	Torque Detection Level 1	Cn-32= 160% Tq. Det. Level 1	0~200%	1%	160%	3-23
	Cn-33	Torque Detection Time 1	Cn-33= 00.1s Tq. Det. Time 1	0.0~25.5s	0.1s	0.1s	
Carrier Frequency	Cn-34	Carrier frequency setting	Cn-34= 6 Carry_Freq Setting	1~6	1	6	3-24
Speed Search Control	Cn-35	Speed Search Detection Level	Cn-35= 150% Sp-Search Level	0~200%	1%	150%	3-24
	Cn-36	Speed Search Time	Cn-36= 02.0s Sp-Search Time	0.1~25.5s	0.1s	2.0s	
	Cn-37	Min. Baseblock Time	Cn-37= 0.5s Min. B.B. Time	0.5~5.0s	0.1s	0.5s	
	Cn-38	V/F Curve in Speed Search	Cn-38= 100 Sp-search V/F Gain	10~100%	1%	100%	
Low Voltage Detection	Cn-39	Low Voltage Alarm Detection Level	Cn-39= 200V Low Volt. Det. Level	150~210V	1V	200V *1	3-26
Slip Comp.	Cn-40	Slip Compensation Primary Delay Time	Cn-40= 02.0s Slip Filter	0.0~25.5s	0.1s	2.0s	3-26
S-curve time	Cn-41	S-curve Characteristic Time at Accel. Start	Cn-41= 0.0s S1 Curve Time	0.0~1.0s	0.1s	0.0s	3-26
	Cn-42	S-curve Characteristic Time at Accel. End	Cn-42= 0.0s S2 Curve Time	0.0~1.0s	0.1s	0.0s	
	Cn-43	S-curve Characteristic Time at Decel. start	Cn-43= 0.0s S3 Curve Time	0.0~1.0s	0.1s	0.0s	
	Cn-44	S-curve Characteristic Time at Decel. end	Cn-44= 0.0s S4 Curve Time	0.0~1.0s	0.1s	0.0s	

Function	Parameter No.	Name	LCD display (English)	Setting range	Setting Unit	Factory Setting	Ref. Page
Speed feedback control	Cn-45	PG Parameter	Cn-45= 0000.0 PG Parameter	0.0~3000.0P/R	0.1P/R	0.0P/R	3-27
	Cn-46	Pole no. of Motor	Cn-46= 04P Motor Pole	2~32P	2P	4P	
	Cn-47	ASR Proportional Gain 1	Cn-47= 0.00 ASR Gain 1	0.00~2.55	0.01	0	
	Cn-48	ASR Integral Gain 1	Cn-48= 01.0s ASR Intgl. Time 1	0.1~10.0S	0.1s	1.0s	
	Cn-49	ASR Proportional Gain 2	Cn-49= 0.02 ASR Gain 2	0.00~2.55	0.01	0.02	
	Cn-50	ASR Integral Gain 2	Cn-50= 01.0s ASR Intgl. Time 2	0.1~10.0S	0.1s	1.0s	
	3-28	Cn-51	ASR Upper Bound	Cn-51= 05.0% ASR Up Bound	0.1~10.0%	0.10%	5.00%
		Cn-52	ASR Lower Bound	Cn-52= 00.1% ASR Low Bound	0.1~10.0%	0.10%	0.10%
		Cn-53	Excessive Speed Deviation Detection Level	Cn-53= 10% Sp.Deviat. Det.Level	1~50%	1%	10%
		Cn-54	Overspeed Detection Level	Cn-54= 110% Over Sp.Det. Level	1~120%	1%	110%
PID Control	Cn-55	PID Integral Upper Bound	Cn-55= 100% PID I-Upper	0~109%	1%	100%	3-28
	Cn-56	PID Primary Delay Time Constant	Cn-56= 0.0s PID Filter	0.0~2.5s	0.1s	0.0s	
Sensorless Vector Control	Cn-57	Motor Line-to-Line Resistance (R1)	Cn-57= 02.233Ω Mtr LINE_R	0.001~60.000Ω	0.001Ω	2.233Ω*4	3-28
	Cn-58	Motor Rotor Equivalent Resistance (R2)	Cn-58= 01.968Ω Mtr ROTOR_R	0.001~60.000Ω	0.001Ω	1.968Ω*4	3-29
	Cn-59	Motor Leakage Inductance (Ls)	Cn-59= 9.6mH Mtr LEAKAGE_X	0.01~200.00mH	0.01mH	9.6mH *4	
	Cn-60	Motor Mutual Inductance (Lm)	Cn-60= 149.7mH Mtr MUTUAL_X	0.1~6553.5mH	0.1mH	149.7mH*4	
	Cn-61	Slip Compensation Gain	Cn-61= 1.00 SLIP GAIN	0.00~2.55	0.01	1	
Torque Detection 2	Cn-62*5	Torque Detection Level 2	Cn-62= 160% Tq. Det. Level 1	0~200%	1%	160%	3-23
	Cn-63*5	Torque Detection Time 2	Cn-63= 00.1s Tq. Det. Time 1	0.0~25.5s	0.1s	0.1s	

\*1 These are for a 230V class inverter. Value(\*1) for a 460V class inverter is double.

\*2 These are for a 230V class inverter. Value(\*2) for a 460V class inverter is double.

\*3 The setting range is 10% ~200% of the inverter rated current.

\*4 The factory setting values will vary based upon the inverter capacity selection (Sn-01) value. In this case, the setting is for 4-pole, 230V, 60Hz, 1Hp TECO standard induction motors.

\*5. These parameters are available for 74.03 and later software version only.

(1) Input Voltage Setting (Cn-01)

- Set inverter voltage to match power supply voltage at input side (e.g. : 200V/230V, 380V/415V/440V/460V)

(2) V/F Curve Parameter Settings (Cn-02~Cn-08)

- The V/F curve can be set to either one of the preset curves (setting Sn-02=0~14) or a customer user-set curve (setting Sn-02=15).
- Setting Cn-02~Cn-08 can be set by the user when Sn-02 has been set to “15”. The user-defined V/F curve can be specified through the settings of Cn-02~Cn-08 as shown in Fig. 17. The factory setting is straight line for the V/F curve. (Cn-05=Cn-07, Cn-06 is not used) as shown below (230V/60Hz case).

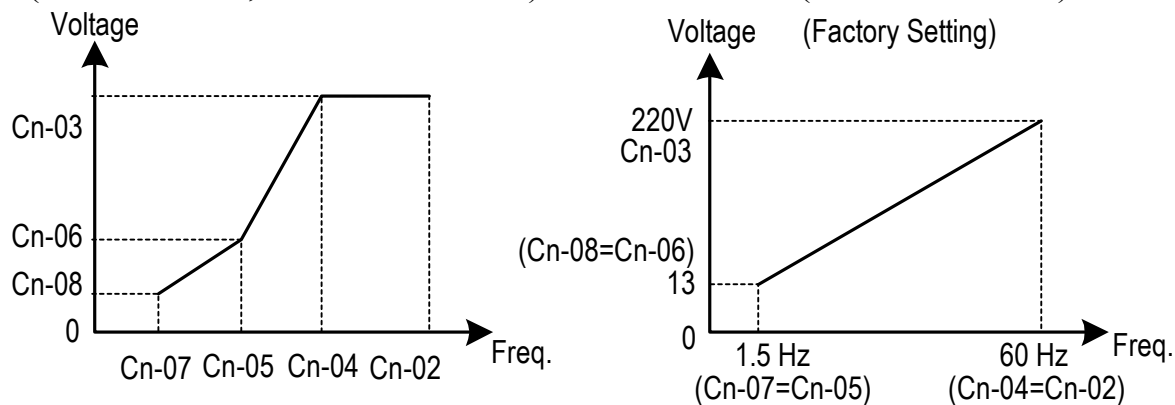

Fig. 17. User-defined V/F curve

- In low speed operation (<3Hz), a larger torque can be generated by increasing the slope of V/F curve. However, the motor will be hot due to over-excitation. At the same time the inverter will be more inclined to fault. Based upon the applied load, properly adjust the V/F curve according to the magnitude of monitored current into the motor.
- The four frequency settings must satisfy the following relationship, otherwise an error message “V/F Curve Invalid” will display.

(a) Max. output freq.  $\geq$  Max. voltage freq.  $>$  Mid. Output freq.  $\geq$  Min. output freq.  
(Cn-02) (Cn-04) (Cn-05) (Cn-07)

(b) Max. output volt.  $\geq$  Mid. output volt.  $>$  Min. output voltage  
(Cn-03) (Cn-06) (Cn-08)

- If Mid. Output frequency (Cn-05) = Min. output frequency (Cn-07), the setting (Cn-06) is not effective.

(3) Motor Rated Current (Cn-09)

- Electronic overload thermal reference current
- The factory setting depends upon the capacity type of inverter (Sn-01).
- The setting range is 10%~200% of the inverter rated output current.
- Set the rated current shown on the motor name plate if not using the TECO 4-pole motor.

(4) Motor No-Load Current (Cn-10)

- This setting is used as a reference value for torque compensation function.
- The setting range is 0~99% of the inverter rated current Cn-09 (100%).
- The slip compensation is enabled when the output current is greater than motor no-load current (Cn-10). The output frequency will shift from f1 to f2 (>f1) for the positive change of load torque. (See Fig. 18)

$$\square \text{Slip compensation} = \frac{\text{Motor rated slip (Cn-11)} \times (\text{Output current} - \text{Motor no-load current (Cn-10)})}{\text{Motor rated current (Cn-09)} - \text{Motor no-load current (Cn-10)}}$$

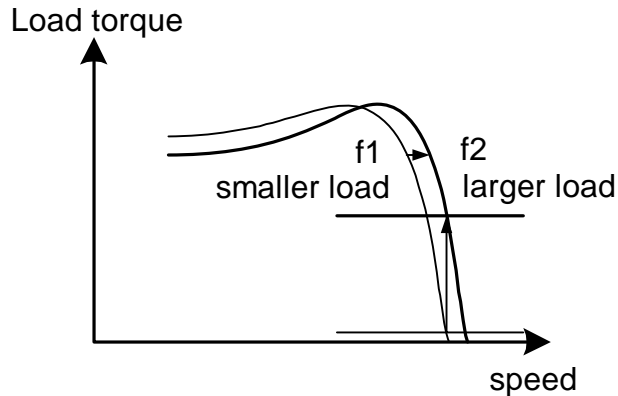

Fig. 18. Output frequency with slip compensation.

(5) Motor Rated Slip (Cn-11)

- This setting is used as a reference value for torque compensation function. See Fig. 17. The setting is 0.0~9.9% as a percentage of motor Max. voltage frequency (Cn-04) as 100%.
- The setting is shown in Fig. 19 in the constant torque and constant output range. If setting Cn-11 is zero, no slip compensation is used.
- There is no slip compensation in the cases when the frequency command is less than the Min. output frequency or during regeneration.

$$\square \text{Motor rated slip (Cn-11)} = \frac{\text{Motor rated freq. (Hz)} \times (\text{Rated speed (RPM)} - \text{Motor No. of poles})}{\text{Max-voltage freq (Cn-04)} \times 120} \times 100\%$$

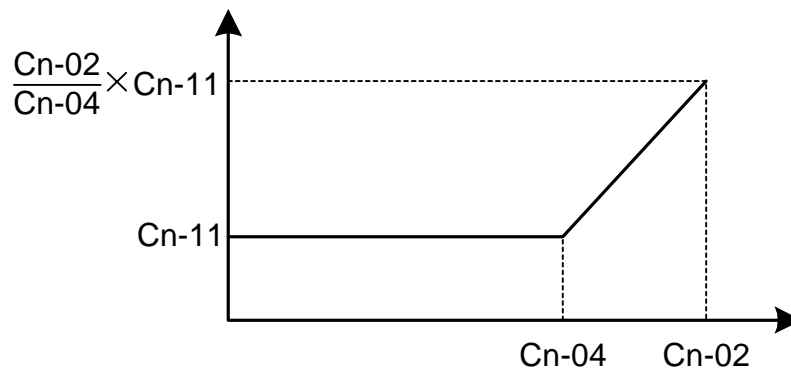

Fig. 19. Slip compensation limit

- (6) Motor Line-to-Line Resistance (Cn-12)
- (7) Motor Iron-Core Loss (Cn-13)
  - It is for torque compensation function. The default setting depends upon the inverter capacity (Sn-01). Normally, the setting does not need to be altered. See Table 10~11 on page 3-39.
- (8) DC Injection Braking Starting Frequency (Cn-14)
- (9) DC Injection Braking Current (Cn-15)
- (10) DC Injection Braking Time at Stop (Cn-16)
- (11) DC Injection Braking Time at Start (Cn-17)
  - The DC injection braking function decelerates by applying a DC current to the motor. This happens in the 2 cases:
    - a. DC injection braking time at start: It is effective for temporarily stopping and then restarting, without regeneration, a motor coasting by inertia.
    - b. DC injection braking time at stop: It is used to prevent coasting by inertia when the motor is not completely stopped by normal deceleration when there is a large load. Lengthening the DC injection braking time (Cn-16) or increasing the DC injection braking current (Cn-15) can shorten the stopping time.
  - For the DC injection braking current (Cn-15), set the value for the current that is output at the time of DC injection braking. DC injection braking current is set as a percentage of inverter rated output current, with the inverter rated output current taken as 100%.
  - For the DC injection braking time at start (Cn-17), set the DC injection braking operating time when the motor is started.
  - For the DC injection braking starting frequency (Cn-14), set the frequency for beginning DC injection braking for deceleration. If the excitation level is less than the Min. output frequency (Cn-07), the DC injection braking will begin from Min. output frequency.
  - If the DC injection braking time at start (Cn-17) is 0.0, the motor starts from the Min. output frequency and no DC injection braking are enabled.
  - If the DC injection braking time at stop (Cn-16) is 0.0, no DC injection braking is enabled. In this case, the inverter output will be blocked off when the output frequency is less than the DC injection braking at start frequency (Cn-14).

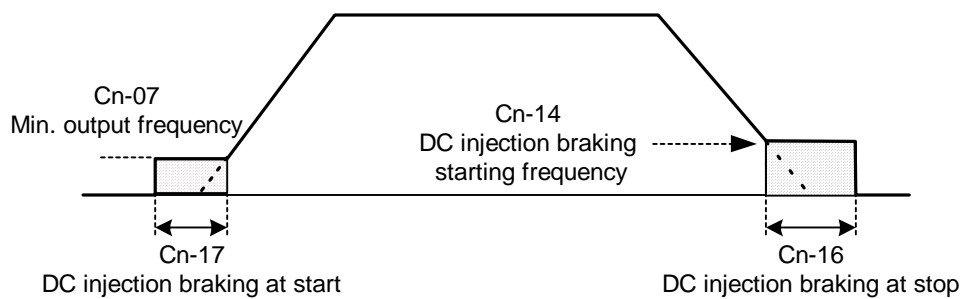

Fig. 20. DC injection braking time chart

(12) Frequency Command Upper Bound (Cn-18)

(13) Frequency Command Lower Bound (Cn-19)

- The upper and lower bounds of the frequency command are set as a percentage of the Max. output frequency (Cn-02 as 100%), in increments of 1%.
- The relationship  $Cn-18 > Cn-19$  must be abided by. If not, an error message “Freq. Limit Setting Error” may occur.
- When the frequency command is zero and a run command is input, the motor operates at the frequency command lower bound (Cn-19). The motor will not operate, however, if the lower limit is set lower than the Min. output frequency (Cn-07).

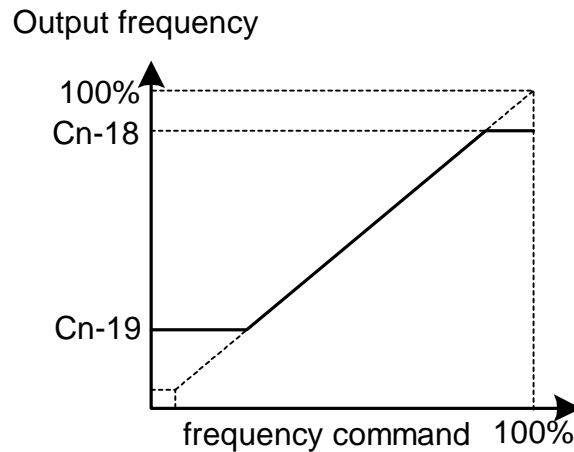

Fig. 21. Upper and lower bounds of the frequency command

(14) Frequency Jump Point 1 (Cn-20)

(15) Frequency Jump Point 2 (Cn-21)

(16) Frequency Jump Point 3 (Cn-22)

(17) Jump Frequency Width (Cn-23)

- These settings allow the “jumping” of certain frequencies within the inverter’s output frequency range so that the motor can operate without resonant oscillations caused by some machine systems.

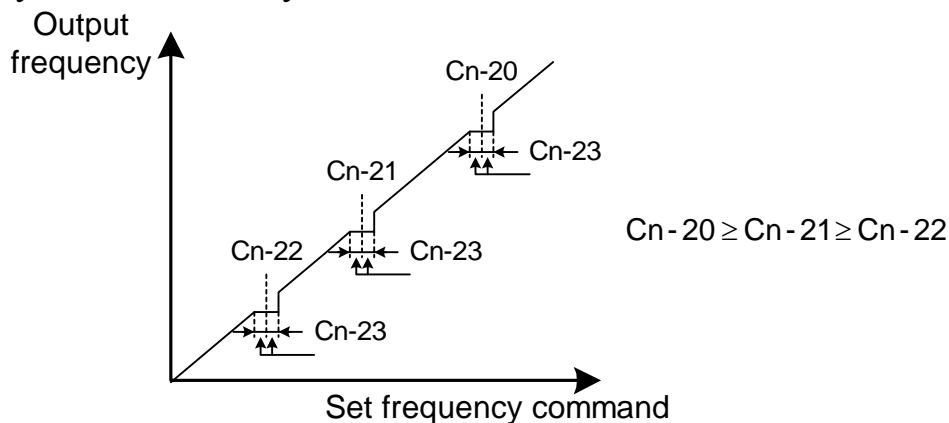



Fig. 22. setting jump frequencies

- Operation is prohibited within the jump frequency range, but changes during acceleration and deceleration are smooth with no jump. To disable this function, set the jump frequency 1~3 (Cn-20~Cn-22) to 0.0Hz.
- For the jump frequency 1~3 (Cn-20~Cn-22), set the center frequency to be jumped.
- Be sure to set the jump so that  $Cn-20 \geq Cn-21 \geq Cn-22$ . If not, a message “Jump frequency setting error” is displayed. For Cn-23, set the jump frequency bandwidth. If Cn-23 is set as 0.0Hz, the jump frequency function is disabled.

(18) Number of Auto Restart Attempt (Cn-24)

- The fault restart function will restart the inverter even when an internal fault occurs during inverter operation. Use this function only when continuing operation is more important than possibly damaging the inverter.
- The fault restart function is effective with the following faults. With other faults, the protective operations will engage immediately without attempting to restart operation.
  - Over-current
  - Ground fault
  - Main circuit over-voltage
- The fault restart count will automatically increase upon the restart activated and will be cleared in the following cases:
  - a. When the operation is normal for 10 minutes after a fault restart is performed.
  - b. When the fault-reset input is received after the protection operation has been activated and the fault confirmed. (e.g., by pressing  or enable Fault reset terminal ③)
  - c. When the power is turned off and on again.
- When one of the multi-function output terminals (RA-RB-RC or R1A-R1B-R1C, DO1, DO2 or R2A-R2C) is set to restart enabled, the output will be ON while the fault restart function is in progress. See page 63 for the setting of (Sn-30~Sn-32).

(19) Stall Prevention Level During Acceleration (Cn-25)

(20) Stall Prevention Level During Running (Cn-26)

- A stall occurs if the rotor can not keep up with the rotating electromagnetic field in the motor stator side when a large load is applied or a sudden acceleration or deceleration is performed. In this case, the inverter should automatically adjust the output frequency to prevent stall.
- The stall prevention function can be set independently for accelerating and running.
- Stall Prevention During Acceleration: See Fig.23. Stop acceleration if Cn-25 setting is exceeded. Accelerate again when the current recovers.
- Stall Prevention During running : See Fig.24. Deceleration is started if the run stall prevention level Cn-26 is exceeded, especially when an impact load is applied suddenly. Accelerate again when the current level is lower than Cn-26.

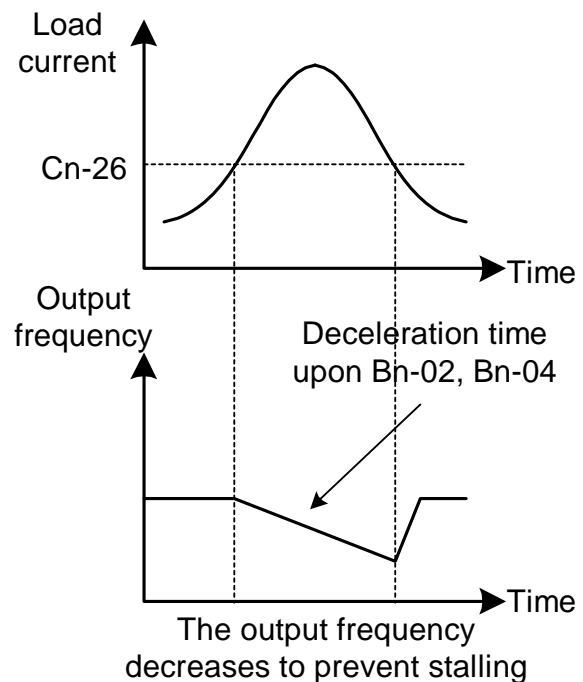
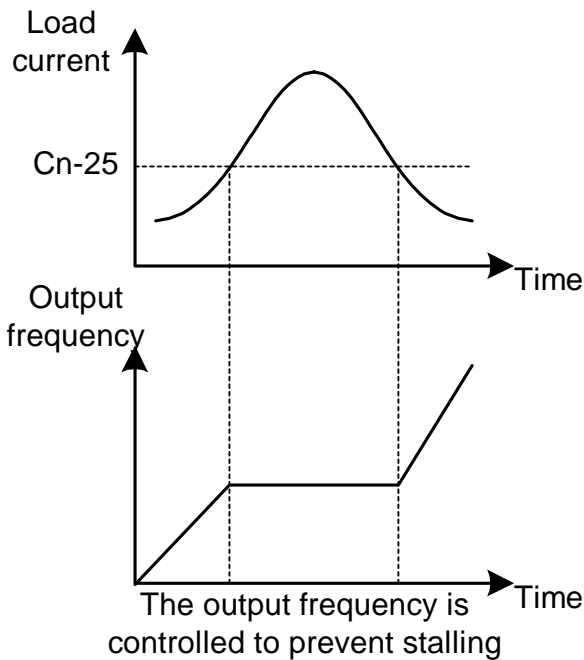

Fig. 23 Acceleration stall prevention function

Fig. 24 Run stall prevention function

- Set the parameters Cn-25 and Cn-26 as a percentage of inverter rated current (100% corresponds to inverter rated current).
- See page 3-48, 3-49 for stall prevention function selection.

(21) Communication Fault Detection Time (Cn-27)

- Please refer to “MODBUS/PROFIBUS Application Manual”.

(22) LCD Digital Operator Display Unit (Cn-28)

- It sets the units to be displayed for the frequency command and frequency monitoring. and sets the decimal points of PID feedback display (Un-34), PID feedback display at 0% and 100% (Bn-45, 46) as described below:

Table 9 LCD digital Operator Display unit

Cn-28	Setting / Reading Content	
	Frequency command/monitoring	PID Feedback
0	Units of 0.01 Hz	
1	Units of 0.01%	
2 to 39	Set in the units of r / min (0 to 39999). $r / \text{min} = 120 \times \text{frequency reference (Hz)} / \text{Cn-28}$ (Set the number of motor poles in Cn-28, only even data is allowed)	Displayed as XXXX Unit specified by Sn-70
40 to 39999	The position of decimal point is set by the value of the 5th digit of Cn-20. 5th digit = 0: Displayed as XXXX 5th digit = 1: Displayed as XXX.X 5th digit = 2: Displayed as XX.XX 5th digit = 3: Displayed as X.XXX The 1st digit to 4th digits of Cn-28 set the value of 100% frequency.	<ul style="list-style-type: none"> <li>• 5th digit = 0: Displayed as XXXX</li> <li>• 5th digit = 1: Displayed as XXX.X</li> <li>• 5th digit = 2: Displayed as XX.XX</li> <li>• 5th digit = 3: displayed as X.XXX</li> </ul> The 1 <sup>st</sup> digit to 4 <sup>th</sup> digits of Cn-28 are not used. Unit specified by Sn-70

- Example 1:

When the set value of 100% speed is 200.0, Cn-28 = 12000 is set.

60% speed is displayed as 120.0 at Cn-28 = 12000.

- Example 2:

When the set value of 100% speed is 65.00, Cn-28 = 26500 is set.

60% speed is displayed as 39.00 at Cn-28 = 26500.

(23) Frequency Agree Detection Level During Acceleration (Cn-29)

(24) Frequency Agree Detection Level During Deceleration (Cn-30)

(25) Frequency Agree Detection Width (Cn-31)

- Frequency detection function: Set the multi-function output terminals (control circuit terminals RA-RB-RC or R1A-R1B-R1C, DO1, DO2 or R2A-R2C) to output the desired Frequency Agree signal, Setting Frequency Agree and Output Frequency Detection level (through proper setting of Sn-30 ~ Sn-32).
- The time chart for Frequency Detection operation is described as follows:

Function	Frequency Detection Operation	Description
Frequency Agree		<ul style="list-style-type: none"> <li>• When output freq. is within freq. command +/- freq. Detection width (Cn-31), frequency agree output is "ON".</li> <li>• Set Sn-30 ~ Sn-32 to be "02" for the setting of frequency agree output.</li> </ul>
Setting Frequency Agree		<ul style="list-style-type: none"> <li>• After acceleration, the output freq. reaches freq. Agree detection level during acceleration (Cn-29) and within freq. Agree detection width (Cn-31), agreed freq. output is "ON".</li> <li>• Set Sn-30 ~ Sn-32 to be "03".</li> </ul>
Output Frequency Detection 1		<ul style="list-style-type: none"> <li>• During acceleration, the output freq. is less than freq. agree detection level during acceleration (Cn-29), output freq. Detection 1 is "ON".</li> <li>• During deceleration, the output freq. is less than freq. agree detection level during deceleration (Cn-30), output freq. Detection 1 is "ON".</li> <li>• Set Sn-30 ~ Sn-32 to be "04" for the setting of output freq. detection.</li> </ul>
Output Frequency Detection 2		<ul style="list-style-type: none"> <li>• During acceleration, the output freq. is larger than freq. Agree detection level during acceleration (Cn-29), output freq. detection 2 is "ON".</li> <li>• During deceleration, the output freq. is larger than freq. Agree detection level during deceleration (Cn-30), output freq. detection 2 is "ON".</li> <li>• Set Sn-30 ~ Sn-32 to be "05" for the setting of output freq. detection.</li> </ul>

- (26) Torque Detection Level 1 (Cn-32)
- (27) Torque Detection Time 1 (Cn-33)
- (28) Torque Detection Level 2 (Cn-62)
- (29) Torque Detection Time 2 (Cn-63)

- Cn-62, 63 are available for 74.03 and later software version only.
- Both Overtorque Detection Function and Undertorque Detection Function are included in Torque Detection Function. The Overtorque Detection Function detects excessive mechanical load from an increase of output current. The Undertorque Detection Function detects broken fan belt from a decrease of output current.
- An overtorque 1 condition is detected when the output current exceeds the Torque Detection Level (Cn-32, Cn-62) for longer than the Torque Detection Time 1 (Cn-33, Cn-63). See Fig.25-a below.
- An undertorque condition is detected when the output current is lower than the Torque Detection Level (Cn-32, Cn-62) for longer than the Torque Detection Time (Cn-33, Cn-63). See Fig.25-b below.
- When Torque Detection 1 is enabled through the setting Sn-12, be sure to set Torque Detection Level 1 (Cn-32) and Torque Detection Time 1 (Cn-33).
- The Multi-Function Output Terminals (Control Circuit Terminals RA-RB-RC or R1A-R1B-R1C, DO1, DO2 or R2A-R2C) can be set to indicate an overtorque condition or an undertorque condition has been detected.

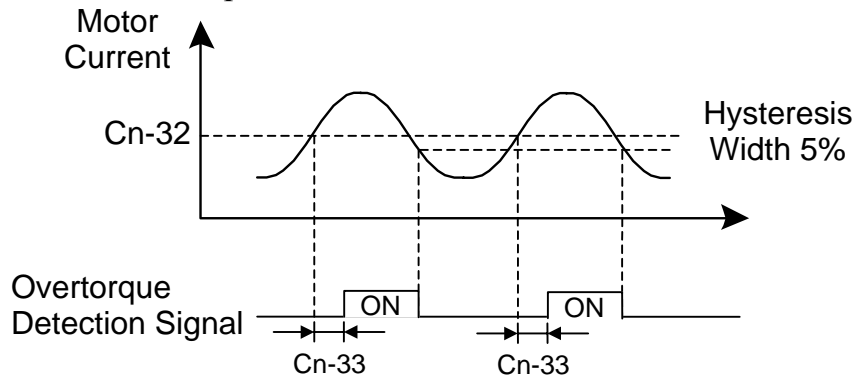

Fig. 25-a. Overtorque Detection Time Chart

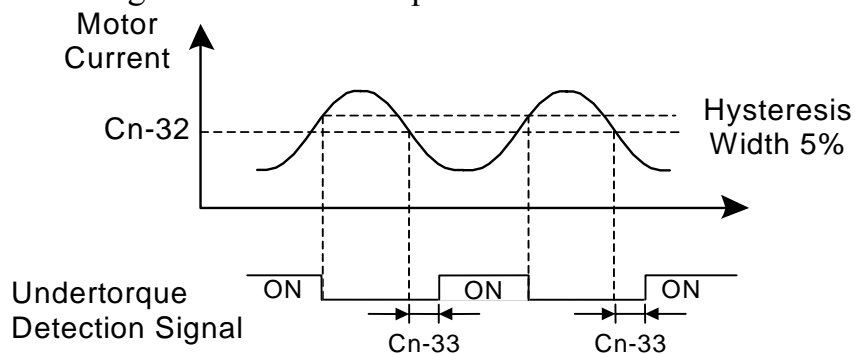
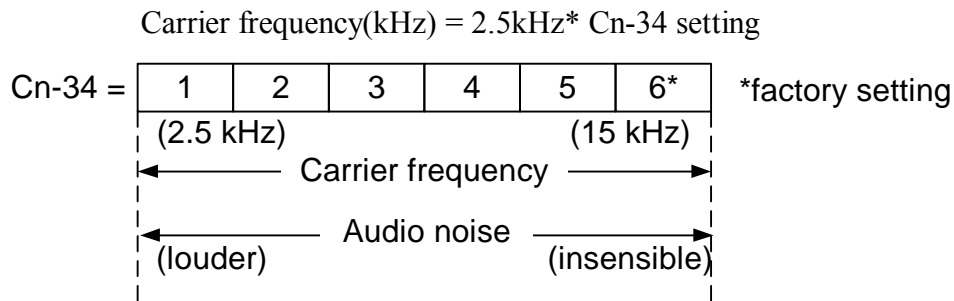

Fig. 25-b. Undertorque Detection Time Chart

- Properly setting the value of Sn-12 (Torque Detection 1 Selection) and Sn-69 (Torque Detection 2 Selection) and will allow
  - Enable only during frequency agreement. Continue operation even after detection.
  - Enable only during frequency agreement. Stop operation after detection.
  - Enable at anytime. Continue operation even after detection.
  - Enable at anytime. Stop operation after detection.

(30) Carrier Frequency Setting (Cn-34)

- Lower the carrier frequency can decrease the noise interference and leakage current. Its setting is shown below.



- The output frequency does not need to be adjusted, except in the following cases.
  - If the wiring distance between the inverter and motor is long, lower the carrier frequency as shown below to allow less leakage current.

Wring distance	< 100ft.	100-165ft.	166-328ft.	≥ 329ft.
Carrier frequency (Cn-34)	<15kHz	<10kHz	<5KHz	<2.5KHz

- If there is great irregularity in speed or torque, lower the carrier frequency.

(31) Speed Search Detection Level (Cn-35)

(32) Speed Search Time (Cn-36)

(33) Min. Baseblock Time (Cn-37)

(34) Speed Search V/F Curve (Cn-38)

- The speed search function will search the speed of a frequency coasting motor from the frequency command or max. frequency downward. And it will restart up smoothly from that frequency or max. frequency. It is effective in situations such as switching from a commercial power supply to an inverter without tripping occurred.
- The timing of speed search function as shown below :

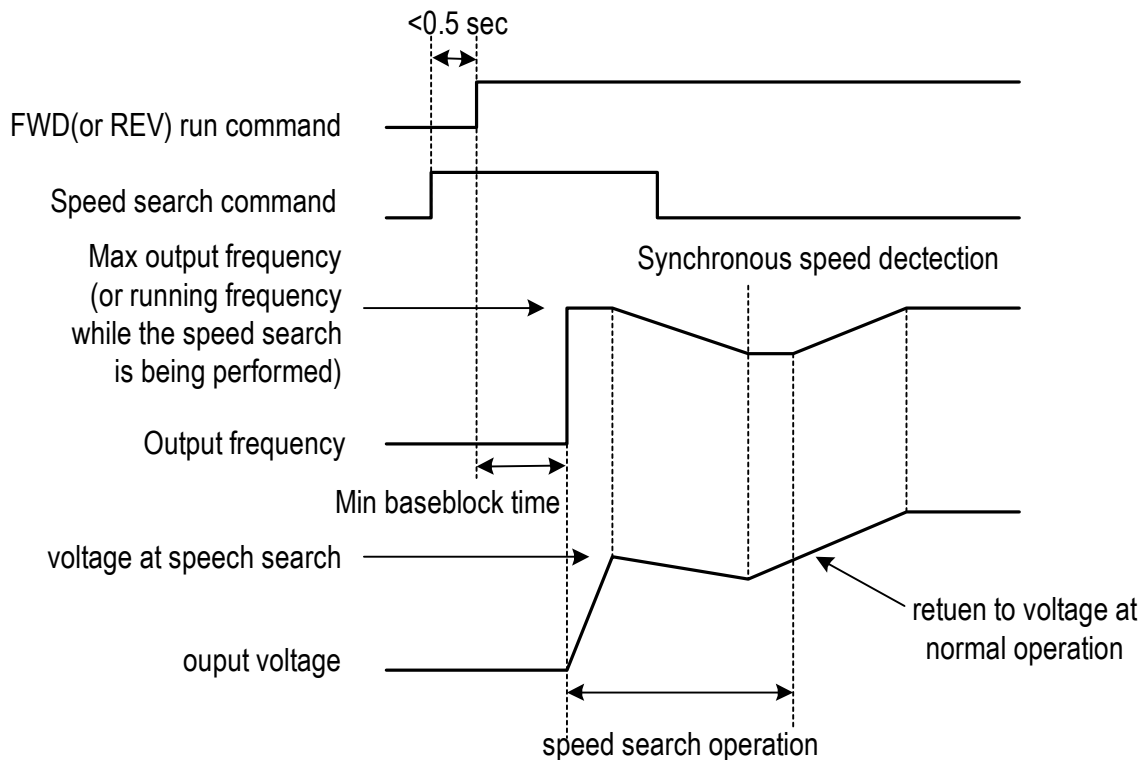
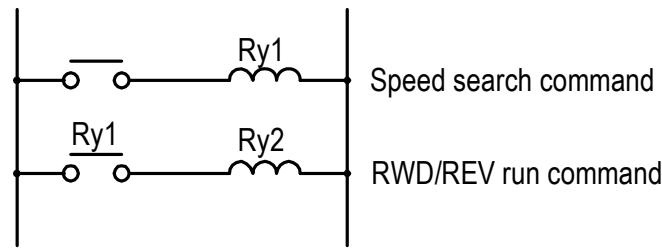

Fig. 26. Speed search timing chart

- The speed search command can be set through the multi-function contact input terminal ⑤ ~ ⑧ (By setting the parameters Sn-25 ~ Sn-28).  
If Sn-25 ~ Sn-28= 21 : Speed search is performed from Max. output frequency and motor is coasting freely.  
If Sn-25 ~ Sn-28= 22 : Speed search starts from the frequency command when the speed search command is enabled.
- After the inverter output is blocked, the user should input speed search command then enable run operation, the inverter will begin to search the motor speed after the min. baseblock time Cn-37.
- Speed search operation, if the inverter output current is less than Cn-35, the inverter will take the output frequency as the real frequency at that time. From those values of real frequency, the inverter will accelerate or decelerate to the set frequency according to the acceleration or deceleration time.
- While the speed search command is being performed, the user can slightly decrease the setting of V/F curve (Cn-38) in order to prevent the OC protection function enabled. Normally, the V/F curve need not be changed. (As below)
- Speed search operating V/F curve = Cn-38 \* (normal operating V/F curve )

Note : 1. The speed search operation will be disabled if the speed search command is enacted from the Max. frequency and the setting frequency. (I.e., Sn-25=20, Sn-26=21 and multi-function input terminals ⑤, ⑥ is used at the same time).

2. Make sure that the FWD/REV command must be performed after or at the same time with the speed search command. A typical operation sequence is shown below.



3. When the speed search and DC injection braking are set, set the Min. baseblock time (Cn-37). For the Min. baseblock time, set the time long enough to allow the motor's residual voltage to dissipate. If an overcurrent is detected when starting a speed search or DC injection braking, raise the setting Cn-37 to prevent a fault from occurring. As a result, the Cn-37 setting cannot be set too small.

(35) Low Voltage Alarm Detection Level (Cn-39)

- In most cases, the default setting Cn-39 need not be changed. If an external AC reactor is used, decrease the low voltage alarm detection level by adjusting Cn-39 setting smaller. Be sure to set a main-circuit DC voltage so that a main circuit undervoltage is detected.

(36) Slip Compensation Primary Delay Time (Cn-40)

- In most cases, the setting Cn-40 need not be changed. If the motor speed is not stable, increase the Cn-40 setting. If the speed response is slow, decrease the setting of Cn-40.

(37) S-curve Characteristic Time at Acceleration Start (Cn-41)

(38) S-curve Characteristic Time at Acceleration End (Cn-42)

(39) S-curve Characteristic Time at Deceleration Start (Cn-43)

(40) S-curve Characteristic Time at Deceleration End (Cn-44)

- Using the S-curve characteristic function for acceleration and deceleration can reduce shock to the machinery when stopping and starting. With the inverter, S-curve characteristic time can be set respectively for beginning acceleration, ending acceleration, beginning deceleration and ending deceleration. The relation between these parameters is shown in Fig. 27.

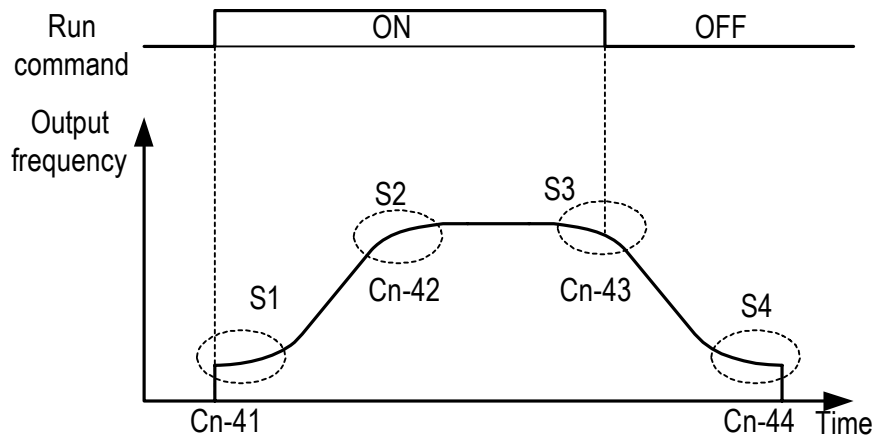

Fig. 27. S curve

- After the S-curve time is set, the final acceleration and deceleration time will be as follows:

- Acc. time = selected Acc. Time 1 (or 2) +  $\frac{(Cn-41) + (Cn-42)}{2}$
- Dec. time = selected Dec. Time 1 (or 2) +  $\frac{(Cn-43) + (Cn-44)}{2}$

(41) PG Parameter (Cn-45)

- The parameter is set in the unit of pulse/revolution. The factory setting is 0.1 P/R.

(42) Pole Number of Motor (Cn-46)

- Cn-45 and Cn-46 must meet the following relationship:

$$\frac{2 * Cn-45 * Cn-02}{Cn-46} < 32767$$

- If not, an error message “Input Error” will be displayed

(43) ASR Proportion Gain 1 (Cn-47)

(44) ASR Integral Gain 1 (Cn-48)

- Set the proportion gain and integral time of the speed control (ASR)

(45) ASR Proportion Gain 2 (Cn-49)

(46) ASR Integral Gain 2 (Cn-50)

- Use these constants to set different proportional gain and integral time settings for high-speed operation.

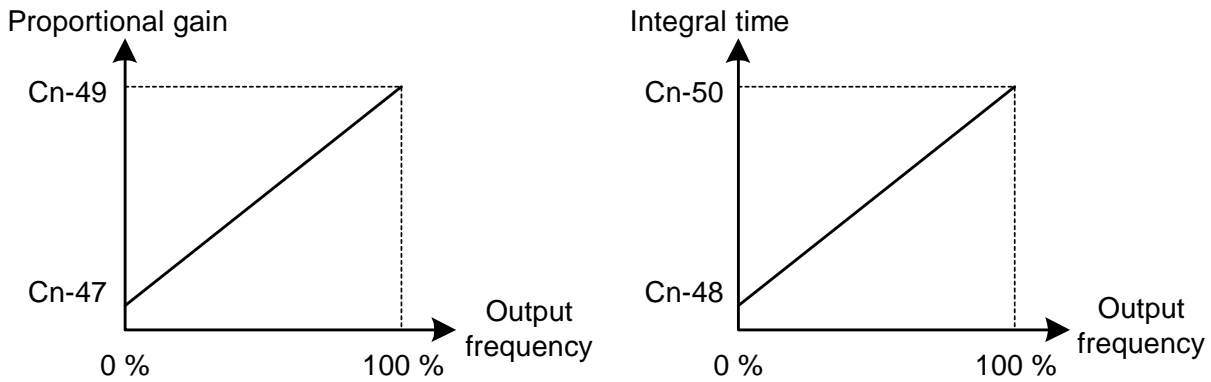

Fig. 28.

- (47) ASR Upper Bound (Cn-51)
- (48) ASR Lower Bound (Cn-52)
  - These settings of Cn-51 and Cn-52 will limit the ASR range.
- (49) Excessive Speed Deviation Detection Level (Cn-53)
  - This parameter set the level of detecting PG speed deviation. The value of Cn-02 is referred as 100%, the default unit setting is 1%.
- (50) Overspeed Detection Level (Cn-54)
  - Set this parameter for detecting overspeed. The value of Cn-02 is referred as 100%, the default unit setting is 1%. Please refer to the setting of Sn-43.
- (51) PID Integral Upper Bound (Cn-55)
- (52) PID Primary Delay Time Constant (Cn-56)
  - Please refer to Fig. 14 “Block diagram for PID control in inverter”
  - The parameter Cn-55 prevents the calculated value of the integral control of PID from exceeding the fixed amount. The value is limited within 0-109% of Max. output frequency (100%). Increase Cn-55 will improve the integral control. If hunting cannot be reduced by decreasing the Bn-18 or increasing Cn-56, Cn-55 has to decrease. If the setting of Cn-55 is too small, the output may not match the target setting.
  - The parameter Cn-56 is the low-pass filter setting for PID control output. If the viscous friction of the mechanical system is high, or if the rigidity is low, causing the mechanical system to oscillate, increase the setting Cn-56 so that it is higher than the oscillation period. It will decrease the responsiveness, but it will prevent the oscillation.
- (53) Motor Line-to-Line Resistance R1 (Cn-57)
  - Set the motor’s terminal resistance (including the motor external cable resistance) in  $\Omega$  unit.
  - The default setting depends upon the type of inverter (but do not include the motor external motor cable resistance).

- This value will be automatically set during autotuning. See “Motor parameter autotuning selection” on page 3-73.
- Increase the setting when the generating torque is not large enough at low speed.
- Decrease the setting when the generating torque is extremely high and cause overcurrent trip at low speed.

(54) Motor Rotor Equivalent Resistance R2 (Cn-58)

- Set the motor’s rotor Y-equivalent model resistance in  $\square$  unit.
- The default setting depends upon the type of inverter. Normally this value isn’t shown on the motor’s nameplate, so it might be necessary to contact motor manufacturer.
- This value will be automatically set during autotuning. See “Motor parameter autotuning selection” on page 3-73.

(55) Motor Leakage Inductance Ls (Cn-59)

- Set the motor’s rotor Y-equivalent model leakage inductance in mH unit.
- The default setting depends upon the type of inverter.
- This value will be automatically set during autotuning. See “Motor parameter autotuning selection” on page 3-73.

(56) Motor Mutual Inductance Lm (Cn-60)

- Set the motor Y-equivalent model mutual inductance in mH unit.
- The default setting depends upon the type of inverter.
- This value will be automatically set during autotuning. See “Motor parameter autotuning selection” on page 3-73.

**Note: The Induction Motor Y-equivalent model**

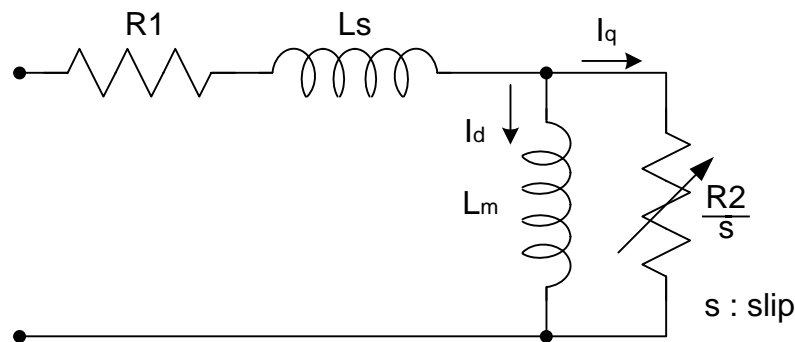

(57) Slip Compensation Gain (Cn-61)

- The parameter Cn-61 improves speed accuracy while operating with a load.
- Usually, the setting Cn-61 need not be changed. Adjust the setting if the speed accuracy is needed to improve.
- When actual speed is low, increase the set value.
- When actual speed is high, decrease the set value.

### 3.4 System Parameters Sn-□□

Function	Parameter No.	Name	LCD display (English)	Description	Factory Setting	Ref. Page
Capacity Setting	Sn-01	Inverter Capacity Selection	Sn-01= 01 220V 1HP	Inverter capacity selection	*1	3-39
V/F Curve	Sn-02	V/F Curve Selection	Sn-02= 01 V/F curve	0~14 : 15 fixed V/F curve pattern 15 : arbitrary V/F pattern selection		3-40
Operator Status	Sn-03	Operator Display	Sn-03= 00 Setting Valid	0 : An-□□, Bn-□□, Cn-□□, Sn-□□ setting & reading enabled 1 : An-□□, setting & reading enabled Bn-□□, Cn-□□, Sn-□□ reading only 2~5 : reserved 6 : clear fault message 7 : 2-wire initialization (230V/460V) 8 : 3-wire initialization (230V/460V) 9 : 2-wire initialization (200V/415V) 10 : 3-wire initialization (200V/415V) 11 : 2-wire initialization (200V/380V) 12 : 3-wire initialization (200V/380V) 13~15 : reserved		3-43
Operation Control Mode Selection	Sn-04	Run Source Selection	Sn-04= 0 Run source Operator	Run source 0 : Operator 1 : Control terminal 2 : RS-485 communication	0	3-43
	Sn-05	Frequency Command Selection	Sn-05= 0 Ref. Cmd. Operator	Frequency Command 0 : Operator 1 : Control circuit terminal 2 : RS-485 communication 3 : Pulse input	0	
	Sn-06	Stopping Method Selection	Sn-06= 0 Dec. Stop	0 : Deceleration to Stop 1 : Coast to Stop 2 : Whole_range braking stop 3 : Coast to Stop with Timer (restart after time Bn-02)	0	
	Sn-07	Priority of Stopping	Sn-07= 0 Stop Key Valid	If operation command from control terminal or RS-485 communication port 0 : operator stop key effective 1 : operator stop key not effective	0	3-45
	Sn-08	Prohibition of REV Run	Sn-08= 0 Allow Reverse	0 : reverse run enabled 1 : reverse run disabled	0	
	Sn-09	Output Frequency Up/Down Function	Sn-09= 0 Inhibit UP/DOWN	0 : Reference frequency is changed through the key "UP/DOWN" pressing, later followed by key "EDIT/ENTER" pressing, and then this output freq. will be acknowledged. 1 : reference frequency will be acknowledged immediately after the key "UP/DOWN" pressing.	0	

Function	Parameter No.	Name	LCD display (English)	Description	Factory Setting	Ref. Page
Operation Control Mode Selection	Sn-10	Frequency Command Characteristics Selection	Sn-10= 0 Ref. Cmd. Fwd. Char.	0 : Reference command has forward characteristics (0~10V or 4~20mA/0~100%) 1 : Reference command has reverse characteristics (10~0V or 20~4mA/0~100%)	0	3-46
	Sn-11	Scanning Times at Input Terminal	Sn-11= 0 Scan Time 5 ms	0 : scan and confirm once per 5 ms 1 : continuously scan and confirm twice per 10 ms	0	
	Sn-12	Torque Detection 1 Selection	Sn-12= 0 Tq.Detect Invalid	Option 5-8 are available for 74.03 and later software version only. 0 : Torque detection function 1 is not effective. 1 : Overtorque is detected only at frequency agree. Continue operation after detection. 2 : Overtorque is detected only at frequency agree. Stop operation after detection. 3 : Overtorque is detected during running (Accel.,Decel. included). Continue operation after detection. 4 : Overtorque is detected during running (Accel., Decel included). Stop operation after detection. 5 : Undertorque is detected only at frequency agree. Continue operation after detection. 6 : Undertorque is detected only at frequency agree. Stop operation after detection. 7 : Undertorque is detected during running (Accel.,Decel. included). Continue operation after detection. 8 : Overtorque is detected during running (Accel., Decel included). Stop operation after detection.	0	3-47
	Sn-13	Output Voltage Limit Selection	Sn-13= 0 V Limit Invalid	0 : V/F output voltage is limited 1 : V/F output voltage is not limited	0	
Protection Characteristic selection	Sn-14	Stall Prevention During Acc. Function Selection	Sn-14= 1 Acc. Stall Valid	0 : invalid (Too much a torque may cause the stall) 1 : valid (stop acceleration if current exceeds Cn-25 setting)	1	3-48
	Sn-15	Stall Prevention During Dec. Function Selection	Sn-15= 1 Dec. Stall Valid	0 : invalid (installed with external brake unit) 1 : valid (no external brake unit used)	1	

Function	Parameter No.	Name	LCD display (English)	Description	Factory Setting	Ref. Page
Protection Characteristic selection	Sn-16	Stall Prevention During Running Function Selection	Sn-16= 1 Run Stall Valid	0 : invalid 1 : valid –Deceleration time1 for stall prevention during running (no external brake unit used) 2 : valid –Deceleration time2 for stall prevention during running (no external brake unit used)	1	3-49
	Sn-17	Fault Retry Setting	Sn-17= 0 Retry No O/P	0 : Do not output fault retry. (The fault contact does not operate.) 1 : Output fault retry. (The fault contact operates.)	0	
	Sn-18	Operation Selection At Power Loss	Sn-18= 0 PwrL_to_ON Stop O/P	0 : stop running 1 : continue to run	0	
	Sn-19	Zero Speed Braking Operation Selection	Sn-19= 0 Z_braking Invalid	(analog) Speed reference is 0 during running on, the braking function selection 0 : invalid 1 : valid	0	
Protection Characteristic Selection	Sn-20	External Fault Contact ③ Contact Selection	Sn-20= 0 Term.3 NO_Cont.	0 : A-contact (normally open input) 1 : B-contact (normally close input)	0	3-50
	Sn-21	External Fault Contact ③ Detection Selection	Sn-21= 0 All Time Ext. Fault	0 : detect all time 1 : detect only during operation	0	
	Sn-22	External Fault Operation Selection	Sn-22= 1 Ext. Fault Free run	0 : dec. to stop (upon dec. time1 Bn-02) 1 : coast (free run) to stop 2 : dec. to stop (upon dec. time1 Bn-04) 3 : continue operating	1	
	Sn-23	Motor Overload Protection Selection	Sn-23= 1 Cold Start Over Load	Electronically motor overload protection selection 0 : electronically motor overload protection invalid 1 : standard motor cold start overload protection characteristics 2 : standard motor hot start overload protection characteristics 3 : special motor cold start overload protection characteristics 4 : special motor hot start overload protection characteristics	1	
	Sn-24	Frequency Command Characteristics Selection at External Analog Input Terminal	Sn-24= 0 ~ Cmd. VIN	Frequency command characteristics selection at external analog input terminal 0 : voltage signal 0~10V (VIN) 1 : current signal 4~20mA (AIN) 2 : addition of voltage signal 0~10V and current signal 4~20 mA (VIN+AIN) 3 : subtraction of current signal 4~20mA and voltage signal 0~10V (VIN-AIN)	0	3-51

Function	Parameter No.	Name	LCD display (English)	Description		Factory Setting	Ref. Page
Multi-function Input Contact Selection	Sn-25	Multi-Function Input Terminal ㊶ Function Selection	Sn-25= 02 Multi-Fun. Command1	00~25	The factory setting is multi-function command1	02	3-51
	Sn-26	Multi-Function Input Terminal ㊷ Function Selection	Sn-26= 03 Multi-Fun. Command2	01~26	The factory setting is multi-function command2	03	
	Sn-27	Multi-Function Input Terminal ㊸ Function Selection	Sn-27= 06 Jog Command	02~27	The factory setting is jog command	06	
	Sn-28	Multi-Function Input Terminal ㊹ Function Selection	Sn-28= 07 Acc. & Dec Switch	03~29	The factory setting is Acc. & Dec. Interrupt	07	
Multi-function Analog Input Selection	Sn-29	Multi-Function Analog Input (AUX) Function Selection	Sn-29= 00 Auxiliary Freq. Cmd.	00~16	Multi-function analog input terminal (AUX) as Auxiliary frequency command. (factory setting)	00	3-60
Multi-function Digital Output Selection	Sn-30	Multi-Function Output Terminal (RA-RB-RC) Function Selection	Sn-30= 13 Fault	00~25	Terminal (RA-RB-RC or R1A-R1B-R1C) as fault output (factory setting)	13	3-63
	Sn-31	Multi-Function Output Terminal (DO1) Function Selection	Sn-31= 00 Running	00~25	Terminal (DO1-DOG) as digital output during running (factory setting).	00	
	Sn-32	Multi-Function Output Terminal (DO2) Function Selection	Sn-32= 01 Zero Speed	00~25	Terminal (DO2-DOG or R2A-R2C) as digital output at zero speed (factory setting)	01	
Multi-function Analog Output Selection	Sn-33	Multi-Function Analog Output (AO1) Function Selection	Sn-33= 00 Term. AO1 Freq. Cmd.	0 : Freq. Cmd. (10.V/MAX frequency command, Cn-02) 1 : Output frequency (10.V/MAX. output frequency) 2 : Output current (10.V/input rated current) 3 : Output voltage (10.V/input voltage, Cn-01) 4 : DC voltage (10.V/400.V or 10.V/800.V)		00	3-67
	Sn-34	Multi-Function Analog Output (AO2) Function Selection	Sn-34= 01 Term. AO2 O/P Freq.	5 : External analog input command VIN (0.~10.V/0.~10.V) 6 : External analog input command AIN (0.~10.V/4.~20.mA) 7 : Multi-function analog input (AUX) (10.V/10.V) 8 : PID control input 9 : PID control output1 10:PID control output2 11:Communication Control		01	
	Sn-35	Pulse Output Multiplier Selection	Sn-35= 1 Pulse Mul. 6	When multi-function output terminal (DO1,DO2) is set as pulse signal output 0:1F 1:6F 2:10F 3:12F 4:36F		1	3-67

Function	Parameter No.	Name	LCD display (English)	Description	Factory Setting	Ref. Page
RS-485 Communication Function	Sn-36	Inverter Address	Sn-36= 01 Inverter Address	Inverter address can be set as 1~31	01	3-68
	Sn-37	RS-485 Comm. Baud Rate Setting	Sn-37= 1 Baud rate 2400	0 : 1200 bps 1 : 2400 bps 2 : 4800 bps 3 : 9600 bps	1	
	Sn-38	RS-485 Comm. Transmission Parity Setting	Sn-38= 0 Reversed Bit	0 : no parity 1 : even parity 2 : odd parity	0	
	Sn-39	RS-485 Comm. Fault Stop Selection	Sn-39= 0 1st. Dec. stop	0 : deceleration to stop (Bn-02) 1 : coast to stop 2 : deceleration to stop (Bn-04) 3 : continue to run	0	
PG Speed Control	Sn-40	PG Speed Control Function	Sn-40= 0 PG Invalid	0 : without speed control 1 : with speed control 2 : with speed control but no integration control during Acc/Dec. 3 : with speed control and integration control during Acc/Dec.	0	3-69
	Sn-41	Operation Selection At PG Open Circuit	Sn-41= 0 1st. Dec. Stop	0 : deceleration to stop (Bn-02) 1 : coast to stop 2 : deceleration to stop (Bn-04) 3 : continue to run	0	
	Sn-42	Operation Selection At PG Large Speed Deviation	Sn-42= 0 1st. Dec Stop	0 : deceleration to stop (Bn-02) 1 : coast to stop 2 : deceleration to stop (Bn-04) 3 : continue to run	0	
	Sn-43	Operation Selection At PG Overspeed Detection Deviation	Sn-43= 0 1st. Dec. Stop	0 : deceleration to stop (Bn-02) 1 : coast to stop 2 : deceleration to stop (Bn-04) 3 : continue to run	0	

Function	Parameter No.	Name	LCD display (English)	Description	Factory Setting	Ref. Page
Auto_Run Mode	Sn-44	Operation Mode Selection During Auto_Run	Sn-44= 0 Auto_Run Invalid	0 : Auto_Run mode not effective 1 : Auto_Run mode for one single cycle. (continuing running from the unfinished step if restarting) 2 : Auto_Run mode be performed periodically (continuing running from the unfinished step if restarting) 3 : Auto_Run mode for one single cycle, then hold the speed of final step to run. (continuing running from the unfinished step if restarting) 4 : Auto_Run mode for one single cycle. (starting a new cycle if restarting) 5 : Auto_Run mode be performed periodically (starting a new cycle if restarting) 6 : Auto_Run mode for one single cycle, then hold the speed of final step to run. (starting a new cycle if restarting)	0	3-70
	Sn-45	Auto_Run Mode Operation Selection1	Sn-45= 0 Auto_Run Stop	0 : stop (Bn-02) 1 : forward 2 : reverse	0	
	Sn-46	Auto_Run Mode Operation Selection2	Sn-46= 0 Auto_Run Stop		0	
	Sn-47	Auto_Run Mode Operation Selection3	Sn-47= 0 Auto_Run Stop		0	
	Sn-48	Auto_Run Mode Operation Selection4	Sn-48= 0 Auto_Run Stop		0	
	Sn-49	Auto_Run Mode Operation Selection5	Sn-49= 0 Auto_Run Stop		0	
	Sn-50	Auto_Run Mode Operation Selection6	Sn-50= 0 Auto_Run Stop		0	

Function	Parameter No.	Name	LCD display (English)	Description	Factory Setting	Ref. Page
Auto_Run Mode	Sn-51	Auto_Run Mode Operation Selection7	Sn-51= 0 Auto_Run Stop	0 : stop (Bn-02) 1 : forward 2 : reverse	0	3-70
	Sn-52	Auto_Run Mode Operation Selection8	Sn-52= 0 Auto_Run Stop		0	
	Sn-53	Auto_Run Mode Operation Selection9	Sn-53= 0 Auto_Run Stop		0	
	Sn-54	Auto_Run Mode Operation Selection10	Sn-54= 0 Auto_Run Stop		0	
	Sn-55	Auto_Run Mode Operation Selection11	Sn-55= 0 Auto_Run Stop		0	
	Sn-56	Auto_Run Mode Operation Selection12	Sn-56= 0 Auto_Run Stop		0	
	Sn-57	Auto_Run Mode Operation Selection13	Sn-57= 0 Auto_Run Stop		0	
	Sn-58	Auto_Run Mode Operation Selection14	Sn-58= 0 Auto_Run Stop		0	
	Sn-59	Auto_Run Mode Operation Selection15	Sn-59= 0 Auto_Run Stop		0	
	Sn-60	Auto_Run Mode Operation Selection16	Sn-60= 0 Auto_Run Stop		0	
	Sn-61	Applied Torque Mode	Sn-61= 0 Const. Tq. Load	0 : constant torque 1 : variable(quadratic) torque	0	3-72
	Sn-62	Language Selection	Sn-62= 0 Language: English	0 : English 1 : Traditional Chinese	0	
	Sn-63	Parameter Copy	Sn-63=0 Not Load	0 : not loaded (copied) 1 : upload from digital operator to inverter 2 : download from inverter to digital operator 3 : inspect the EEPROM of digital operator 4 : inspect the EEPROM of inverter	0	
	Sn-64	PID Function	Sn-64=0 PID Invalid	0 : PID invalid 1 : PID valid	0	
	*4 Sn-65	Brake Resistor Protection	Sn-65=0 Protect Invalid	0 : Braking resistor protection invalid 1 : Braking resistor protection valid	0	
*2 Sensorless Vector Control	Sn-66	Motor Parameters Autotuning Selection	Sn-66=0 AUTO TUNE SEL	0 : Autotuning invalid 1 : Autotuning valid	0	3-73
	Sn-67	Control Mode Selection	Sn-67=0 CNTRL MODE SEL	0 : V/F control mode (include V/F control with pulse generator feedback) 1 : Sensorless Vector Control Mode	0	

Function	Parameter No.	Name	LCD display (English)	Description	Factory Setting	Ref. Page
	Sn-68	Control selection	Sn-68=0000 Control selection	<p>The very parameter is available for 30.15 and later version</p> <p>—1: Output phase lose protection function valid —0: Output phase lose protection function invalid</p> <p>—1—: Reserved —0—: Reserved</p> <p>(Bit3 function is available for 30.16 and later version) -1—: ±10V analog voltage input function is valid -0—: ±10V analog voltage input function is invalid</p> <p>1—: Frequency Up/Down hold function valid 0—: Frequency Up/Down hold function invalid</p> <p>* only 4P101C01301 control base board supports input of ±10V analog voltage.</p>	0	3-73
Operation Control Mode Selection	Sn-69 <sup>3</sup>	Torque Detection 2 Selection	Sn-69= 0 Tq.Detect Invalid	<p>0 : Torque detection function 2 is not effective.</p> <p>1 : Overtorque is detected only at frequency agree. Continue operation after detection.</p> <p>2 : Overtorque is detected only at frequency agree. Stop operation after detection.</p> <p>3 : Overtorque is detected during running (Accel.,Decel. included). Continue operation after detection.</p> <p>4 : Overtorque is detected during running (Accel., Decel included). Stop operation after detection.</p> <p>5 : Undertorque is detected only at frequency agree. Continue operation after detection.</p> <p>6 : Undertorque is detected only at frequency agree. Stop operation after detection.</p> <p>7 : Undertorque is detected during running (Accel.,Decel. included). Continue operation after detection.</p> <p>8 : Overtorque is detected during running (Accel., Decel included). Stop operation after detection.</p>	0	3-47

Function	Parameter No.	Name	LCD display (English)	Description	Factory Setting	Ref. Page
	Sn-70 <sup>3</sup>	Engineering Unit	Sn-70= 0 Unit : NONE	0 : NONE 1 : FPM (feet per minute) 2 : CFM (cubic feet per minute) 3 : PSI (pounds per square inch) 4 : GPH (gallons per hour) 5 : GPM (gallons per minute) 6 : in 7 : ft 8 : /s (units per second) 9 : /m (units per minute) 10 : /h (units per hour) 11 : °F 12 : inW (inches in water column) 13 : HP 14 : m/s (meters per second) 15 : MPM (meters per minute) 16 : CMM (cubic meters per minute) 17 : W 18 : kW 19 : m 20 : °C	0	3-74

- \*1. The default setting will depend upon the different inverter capacity.
- \*2. Sensorless vector control is available after the version of 30.00.
- \*3. These parameters are available for 74.03 and later software version only.
- \*4. This parameter is not available after the version of 30.21.

(3) Inverter capacity selection (Sn-01)

- The inverter capacity has already been set at factory according to the following tables. Whenever the control board is replaced, the setting Sn-01 must be set again according to the following tables.
- Whenever the setting Sn-01 has been changed, the inverter system parameter settings should be changed based upon the constant torque (CT) load (setting of Sn-61= 0) or variable torque (VT) load (Sn-61= 1).

Table 10 230V Class Inverter Capacity Selection

Sn-01 setting			001		002		003		004		005		006	
CT(Sn-61=0) VT(Sn-61=1)			CT	VT	CT	VT	CT	VT	CT	VT	CT	VT	CT	VT
Item name														
Inverter rated capacity (KVA)			2		2.7		4		7.5		10.1		13.7	
Inverter rated current (A)			4.8		6.4		9.6		17.5		24		32	
Max. applicable capacity (HP)			1	1	2	2	3	3	5.4	7.5	7.5	10	10	10
Factory Setting	Cn-09	Motor rated current (A)	3.4	3.4	6.1	6.1	8.7	8.7	14.6	20.1	20.1	25.1	25.1	25.1
	Cn-12	Motor line impedance (Ω)	5.732	5.732	2.407	2.407	1.583	1.583	0.684	0.444	0.444	0.288	0.288	0.288
	Cn-13	Core loss torque compensation (W)	64	64	108	108	142	142	208	252	252	285	285	285
	Cn-34	Carrier freq.(kHz)	10	10	10	5	10	10	10	5	10	10	10	10
	Cn-37	Min. baseblock time (sec)	0.5	0.5	0.5	0.5	0.5	0.5	0.5	0.7	0.7	0.7	0.7	0.7
	Sn-02	V/F curve	01	07 <sup>*1</sup>	01	07 <sup>*1</sup>	01	07 <sup>*1</sup>	01	07 <sup>*1</sup>	01	07 <sup>*1</sup>	01	07 <sup>*1</sup>
Max. carrier freq. (kHz)			15	10	15	5	15	15	15	5	15	10	15	15

Sn-01 setting			007		008		009		010		011	
CT(Sn-61=0) VT(Sn-61=1)			CT	VT	CT	VT	CT	VT	CT	VT	CT	VT
Item name												
Inverter rated capacity (KVA)			20.6		27.4		34		41		54	
Inverter rated current (A)			48		64		80		96		130	
Max. applicable capacity (HP)			15	20	20	25	25	25	30	40	40	40
Factory Setting	Cn-09	Motor rated current (A)	36.7	50.3	50.3	62.9	62.9	62.9	72.9	96.7	96.7	96.7
	Cn-12	Motor line impedance (Ω)	0.159	0.109	0.109	0.077	0.077	0.077	0.060	0.041	0.041	0.041
	Cn-13	Core loss torque compensation (W)	370	471	471	425	425	425	582	536	536	536
	Cn-34	Carrier freq.(kHz)	10	5	10	5	10	10	10	5	10	10
	Cn-37	Min. baseblock time (sec)	0.7	0.7	0.7	0.7	1.0	1.0	1.0	1.0	1.0	1.0
	Sn-02	V/F curve	01	07 <sup>*1</sup>	01	07 <sup>*1</sup>	01	07 <sup>*1</sup>	01	07 <sup>*1</sup>	01	07 <sup>*1</sup>
Max. carrier freq. (kHz)			10	5	10	5	10	10	10	5	10	10

Table 11 460V Class Inverter Capacity Selection

Sn-01 setting			021		022		023		024		025		026		027	
CT(Sn-61=0) VT(Sn-61=1)			CT	VT	CT	VT	CT	VT	CT	VT	CT	VT	CT	VT	CT	VT
Item name																
Inverter rated capacity (KVA)			2.2		3.4		4.1		7.5		10.3		12.3		20.6	
Inverter rated current (A)			2.6		4		4.8		8.7		12		15		24	
Max. applicable capacity (HP)			1	1	2	2	3	3	5.4	7.5	7.5	10	10	15	15	20
Factory Setting	Cn-09	Motor rated current (A)	1.7	1.7	2.9	2.9	4	4	7.3	10.2	10.2	12.6	12.6	18.6	18.6	24.8
	Cn-12	Motor line impedance (Ω)	22.927	22.927	9.628	9.628	6.333	6.333	2.735	1.776	1.776	1.151	1.151	0.634	0.634	0.436
	Cn-13	Core loss torque compensation (W)	64	64	108	108	142	142	208	252	252	285	285	370	370	471
	Cn-34	Carrier freq. (kHz)	10	5	10	5	10	10	10	5	10	10	10	5	10	5
	Cn-37	Min. baseblock time (sec)	0.5	0.5	0.5	0.5	0.5	0.5	0.5	0.7	0.7	0.7	0.7	0.7	0.7	0.7
	Sn-02	V/F curve	01	07*1	01	07*1	01	07*1	01	07*1	01	07*1	01	07*1	01	07*1
Max. carrier freq. (kHz)			15	5	15	5	15	15	15	5	15	10	15	5	10	5

Sn-01 setting			028		029		030		031		032		033		034	
CT(Sn-61=0) VT(Sn-61=1)			CT	VT	CT	VT	CT	VT	CT	VT	CT	VT	CT	VT	CT	VT
Item name																
Inverter rated capacity (KVA)			27.4		34		41		54		68		82		110	
Inverter rated current (A)			32		40		48		64		80		96		128	
Max. applicable capacity (HP)			20	25	25	30	30	30	40	50	50	50	60	75	75	100
Factory Setting	Cn-09	Motor rated current (A)	24.8	31.1	31.1	36.3	36.3	36.3	48.7	59.0	59.0	59.0	70.5	80.0	80.0	114
	Cn-12	Motor line impedance (Ω)	0.436	0.308	0.308	0.239	0.239	0.239	0.164	0.133	0.133	0.133	0.110	0.074	0.074	0.027
	Cn-13	Core loss torque compensation (W)	471	425	425	582	582	582	536	641	641	641	737	790	790	1800
	Cn-34	Carrier freq. (kHz)	10	5	10	5	10	10	10	5	10	10	10	5	10	5
	Cn-37	Min. baseblock time (sec)	0.7	0.7	1.0	1.0	1.0	1.0	1.0	1.0	1.0	1.0	1.0	1.0	1.0	1.0
	Sn-02	V/F curve	01	07*1	01	07*1	01	07*1	01	07*1	01	07*1	01	07*1	01	07*1
Max. carrier freq. (kHz)			10	5	10	5	10	10	10	5	10	10	10	5	10	5

\*1 Use the variable torque patterns when there is a quadratic or cubic relationship between the speed and load, such as in fan or pump applications. The user can properly choose the desired (V/f) patterns (Sn-02=04, 05, 06, or 07) based upon the load torque characteristics.

\*2 In the fan or pump applications, the load torque have a quadratic or cubic relationship between the speed and load. The inverter capacity rating can be increased to a value that doubles its own specified capacity rating in some special case. But, due to the real hardware limitation, 230V 1HP, 2HP, 3HP, 10HP, 25HP, 40HP and 460V 1HP, 2HP, 3HP, 30HP, 50HP can not be adapted any larger capacity.

(4) V/F curve selection (Sn-02)

- Set the inverter input voltage (Cn-01) first to match the power supply voltage. The V/f curve can be set to ant of the following.

Sn-02 = 00~14: one of 15 pre-set curve patterns

= 15: V/F pattern can be set by the user through setting of Cn-01~Cn-08

Table 12 V/F curve of 1~2 HP compact size, 230V Class MA inverter \*

		Specifications	Sn-02	V/F Pattern <sup>†</sup>			Specifications	Sn-02	V/F Pattern <sup>†</sup>
General Purpose	50Hz		00		High Starting Torque <sup>‡</sup>	50Hz	Low Starting Torque	08	
				High Starting Torque			09		
	60Hz	60Hz Saturation	01 15		High Starting Torque <sup>‡</sup>	60Hz	Low Starting Torque	10	
	50Hz Saturation	02		60Hz		High Starting Torque	11		
	72Hz		03		Rated Output Operation (Machine Tool)	90Hz	12		
Variable Torque Characteristic	50Hz	Variable Torque 1	04			Rated Output Operation (Machine Tool)	120Hz	13	
		Variable Torque 2	05						
	60Hz	Variable Torque 3	06		180Hz		14		
		Variable Torque 4	07						

\* These values are for the 230V class; double the values for 460V class inverters.

† Consider the following items as the conditions for selecting a V/f pattern.

They must be suitable for

- (1) The voltage and frequency characteristic of motor.
- (2) The maximum speed of motor.

‡ Select high starting torque only in the following conditions.

- (1) The power cable length is long [492ft (150m) and above].
- (2) Voltage drop at startup is large.
- (3) AC reactor is inserted at the input side or output side of the inverter.
- (4) A motor with capacity smaller than the maximum applicable inverter capacity is used.

Table 13 V/F curve of 3~40 HP, 230V Class MA inverter \*

	Specifications	Sn-02	V/F Pattern <sup>†</sup>		Specifications	Sn-02	V/F Pattern <sup>†</sup>		
General Purpose	50Hz	00		High Starting Torque <sup>‡</sup>	50Hz	08			
			09						
	60Hz	60Hz Saturation	01			60Hz	Low Starting Torque	10	
		50Hz Saturation	02				High Starting Torque	11	
	72Hz	03			90Hz	12			
Variable Torque Characteristic	50Hz	Variable Torque 1	04	Rated Output Operation (Machine Tool)	120Hz	13			
		Variable Torque 2	05						
	60Hz	Variable Torque 3	06						
		Variable Torque 4	07						

\* These values are for the 230V class; double the values for 460V class 3~75HP inverters.

† Consider the following items as the conditions for selecting a V/f pattern. They must be suitable for

- (1) The voltage and frequency characteristic of motor.
- (2) The maximum speed of motor.

‡ Select high starting torque only in the following conditions. Normally, the selection if not required.

- (1) The power cable length is long [492ft (150m) and above].
- (2) Voltage drop at startup is large.
- (3) AC reactor is inserted at the input side or output side of the inverter.
- (4) A motor with capacity smaller than the maximum applicable inverter capacity is used.

(5) Operator Display (Sn-03)

- Parameter code (Sn-03= 0 or 1)

Set the parameter Sn-03 as 0 or 1 to determine the access status as follows.

Sn-03	DRIVE mode		PRGM mode	
	Set	Read Only	Set	Read Only
0	An, Bn	Sn, Cn	An, Bn, Sn, Cn	—
1	An	Bn, Sn, Cn	An	Bn, Sn, Cn

- Initialized setting of parameter (Sn-03= 7~12)

Except the parameter of Sn-01~02 and Sn-61, the parameter groups of An-□□, Bn-□□, Cn-□□ and Sn-□□ can be initialized as factory setting according to the different input voltage. At the same time, the terminal ⑤~⑧ can be set as 2-wire or 3-wire operation mode under different setting of Sn-03. Please see 2-/3-wire operation mode on page 3-53.

(6) Run Source Selection (Sn-04)

- The parameter is used to select the source of run command.

Sn-04 = 0 : digital operator  
 = 1 : control circuit terminal  
 = 2 : RS-485 communication

- If Sn-04 is set as 1, the run source is from the control circuit terminal. Under the initial setting of 2-wire operation (through setting of Sn-03=7 or 9 or 11), the run source will be FWD/STOP, REV/STOP.
- If Sn-04 is set as 1, the run source is from the control circuit terminal. Under the initial setting of 3-wire operation (through setting of Sn-03=8 or 10 or 12), the run source will be RUN, STOP, FWD/ REV.
- For more details, see “2-/3- wire operation” on page 3-53.

(7) Frequency Command Setting Method Selection (Sn-05)

- The parameter is used to select the source of frequency command.

Sn-05 = 0 : digital operator  
 = 1 : control circuit terminal  
 = 2 : RS-485 communication

(8) Stopping Method Selection (Sn-06)

- Setting the stopping method used when a stop command is executed.

Setting	Function
0	Deceleration to stop
1	Coast to stop
2	DC braking stop: Stops faster than coast to stop, without regenerative operation.
3	Coast to stop with timer: Run sources are disregarded during decel. time.

- The following diagrams show the operation of each stopping method.

a) Deceleration to Stop (Sn-06= 0)

Deceleration to a stop at a rate set with the selected deceleration time.

b) Coast to Stop (Sn-06= 1)

After the stop command is executed, run source is disregarded until the Min. baseblock time Cn-37 has elapsed.

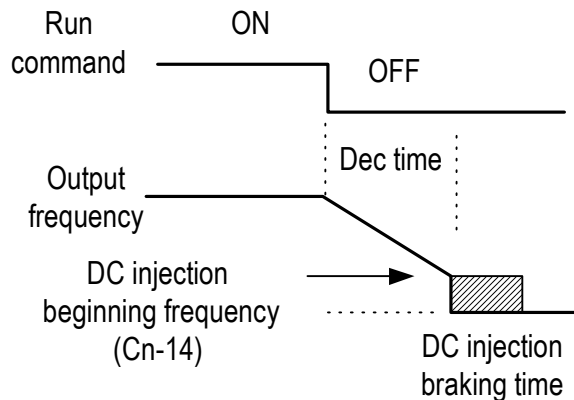

Fig. 29. Deceleration to stop

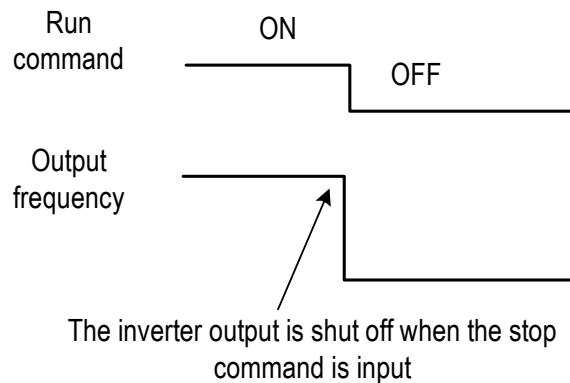

Fig. 30. Coast to Stop

c) Whole Range DC Injection Braking Stop (Sn-06= 2)

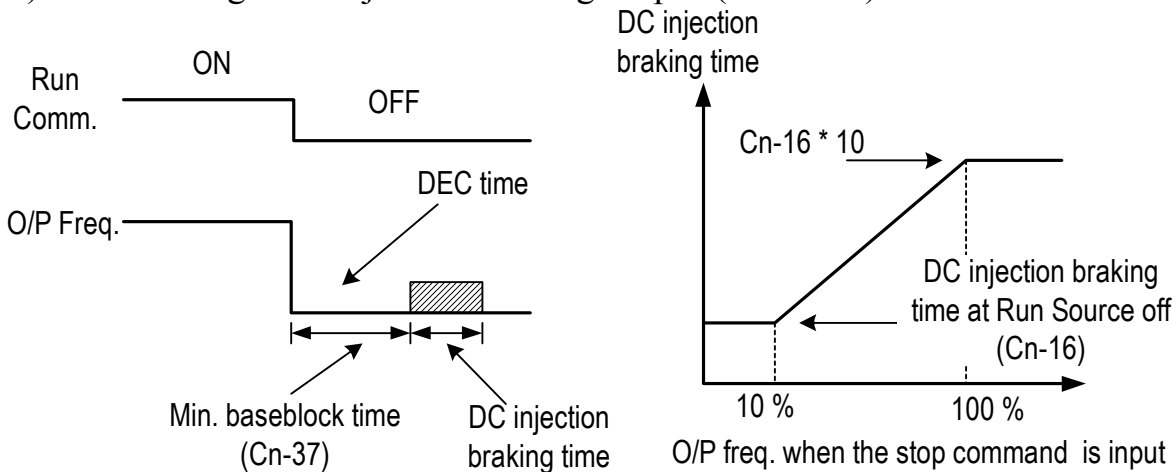

Fig. 31. Whole range DC Injecting Braking Stop

- After the stop command is input and the minimum baseblock time (Cn-37) has elapsed, DC injection braking is applied and the motor stopped.
- The DC injection braking time depends upon the output frequency when the stop command is input and the “DC injection time at stop” setting (Cn-16) as shown in Fig. 31.
- Lengthen the minimum baseblock time (Cn-37) when an overcurrent (OC) occurs during stopping. When the power to an induction motor is turned OFF, the counter-electromotive force generated by the residual magnetic field in the motor can cause an overcurrent to be detected when DC injection braking stop is applied.

d) Coast to Stop with Timer (Sn-06= 3)

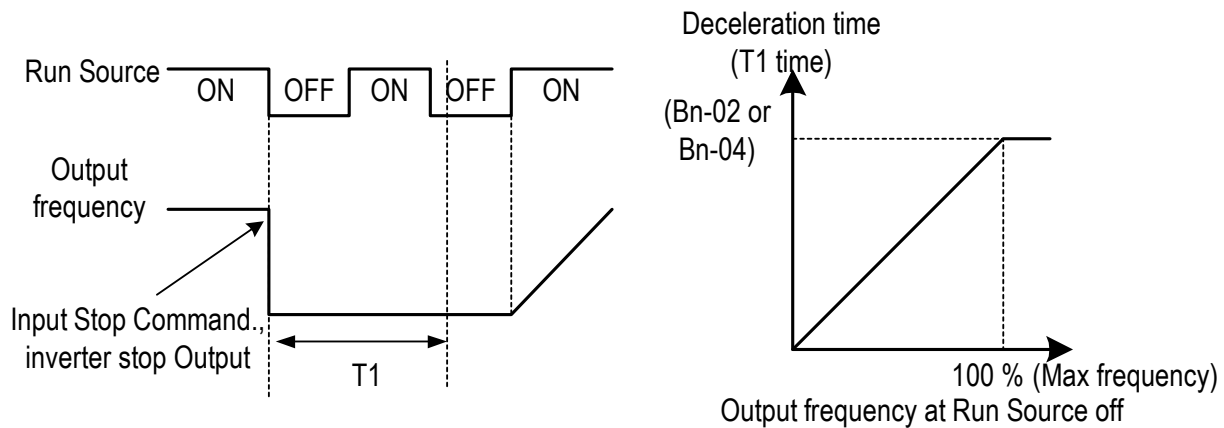

Fig. 32. Coast to Stop with Timer

- After the stop command is executed, run sources are disregarded until the time T1 has elapsed. The time T1 depends upon the output frequency when the stop command is executed and upon the deceleration time (Bn-02 or Bn-04).

(9) Priority of Stopping (Sn-07)



- This parameter enable or disable the STOP key on the digital operator when the run source is from an control circuit terminal or RS-485 communicate port while the motor is running.  
 Sn-07 = 0 : enabled. (The STOP key is enabled at all time during running)  
 = 1 : disabled (The STOP key is disabled when the run source is from control terminal or RS-485 port)



(10) Prohibition of REV Run (Sn-08)

- While the parameter Sn-08 is set as 1. The reverse run of motor is not allowed

(11) Output Frequency UP/DOWN Function (Sn-09)

- The output frequency can be increased or decreased (UP/DOWN) through digital operator

Sn-09 = 0 : Change output frequency through the ( / ) key. The frequency command will be accepted only after the key  has been pressed.

= 1 : Change output frequency through the ( / ) key. The frequency command can be recalled even restarting the inverter if the  key has been pressed at that time.

- The output frequency can be changed (increasing (UP) or decreasing (DOWN)) through either the LCD digital operator or external multi-function input terminal (terminals ⑤ ~ ⑧).

(12) Frequency Command Characteristics Selection (Sn-10)

30.16 previous or later version set Sn-68= - 0 - -

The positive and negative characteristics of analog frequency command (0~10V/4~20mA) is as follow diagram:

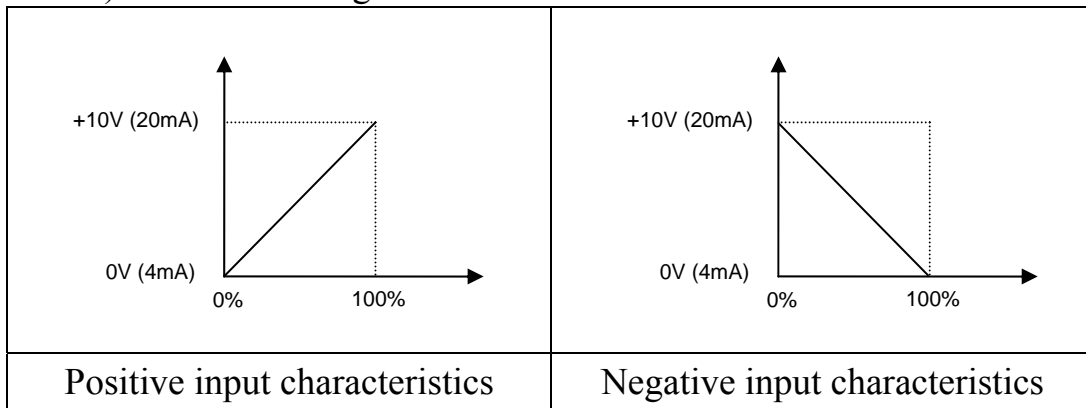

30.17 previous or later version set Sn-68= - 1 - - :

The positive and negative characteristics of analog current input is similar to above description, while of analog voltage input is as follow diagram:

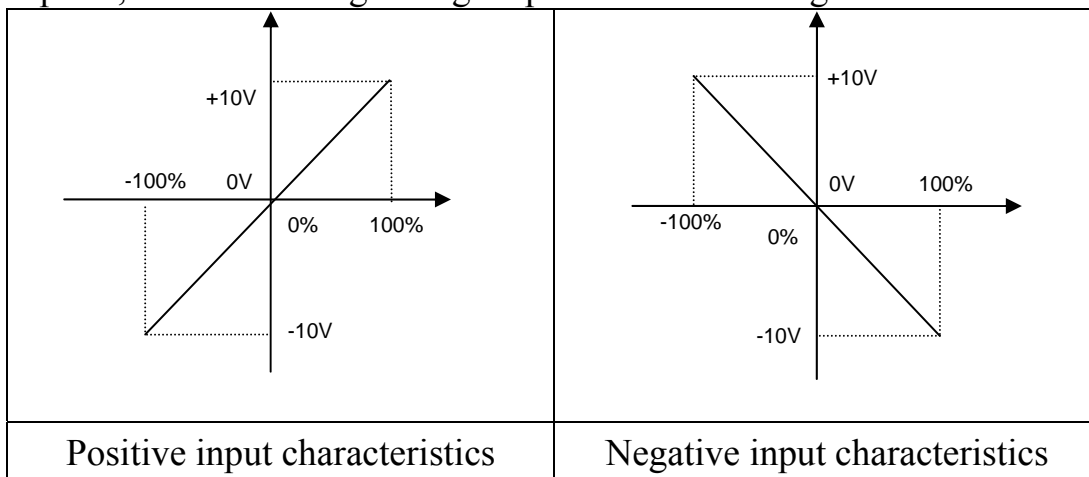

Among Sn-68 set, ' - ' represents 0 or 1.

Only 4P101C01301 control board supports input of -10V~+10V analog voltage.

(13) Scan Time at Input Terminal (Sn-11)

- Setting of scan frequency of input terminal (Forward/Reverse, multi-function input)

Sn-11 = 0 : Scan input terminals every 5ms.

= 1 : Scan input terminals every 10ms.

(14) Torque Detection 1 Selection (Sn-12)

(15) Torque Detection 2 Selection (Sn-69)

- The parameter Sn-69 and settings 5-8 of Sn-12 are available for 74.03 and later software versions.
- The inverter supports 2 sets of torque detection function. Each of them can set as overtorque detection or undertorque detection.
- While Torque Detection 1 is enabled by Sn-12, be sure to set the values of the Torque Detection Level 1 (Cn-32) and Torque Detection Time 1 (Cn-33). While Torque Detection 2 is enabled by Sn-69, be sure to set the values of the Torque Detection Level 2 (Cn-62) and Torque Detection Time 2 (Cn-63).
- An overtorque condition is detected when the Overtorque Detection is enabled, and the current exceeds the Torque Detection Level for longer than the Torque Detection Time.
- An undertorque condition is detected when the Undertorque Detection is enabled, and the current is lower than the Torque Detection Level for longer than the Torque Detection Time.

Sn-12, Sn-69	Function	Display
0	Torque detection disabled	
1	Detect overtorque only during speed agree. Continue operation after detection. (Minor fault)	“Over Torque 1” or “Over Torque 2” blinks
2	Detect overtorque only during speed agree. Stop output after detection (Fault)	“Over Torque 1” or “Over Torque 2” lights
3	Detect overtorque at any time. Continue operation after detection. (Minor fault)	“Over Torque 1” or “Over Torque 2” blinks
4	Detect overtorque at any time. Stop output after detection (Fault)	“Over Torque 1” or “Over Torque 2” lights
5	Detect undertorque only during speed agree. Continue operation after detection. (Minor fault)	“Under Torque 1” or “Under Torque 2” blinks
6	Detect undertorque only during speed agree. Stop output after detection (Fault)	“Under Torque 1” or “Under Torque 2” lights
7	Detect undertorque at any time. Continue operation after detection. (Minor fault)	“Under Torque 1” or “Under Torque 2” blinks
8	Detect undertorque at any time. Stop output after detection (Fault)	“Under Torque 1” or “Under Torque 2” lights

(16) Output Voltage Limitation Selection (Sn-13)

- In low speed region, if the output voltage from V/f pattern is too high, the inverter will be driven into fault status. As a result, the user can use this option to set the upper bound limit of output voltage.

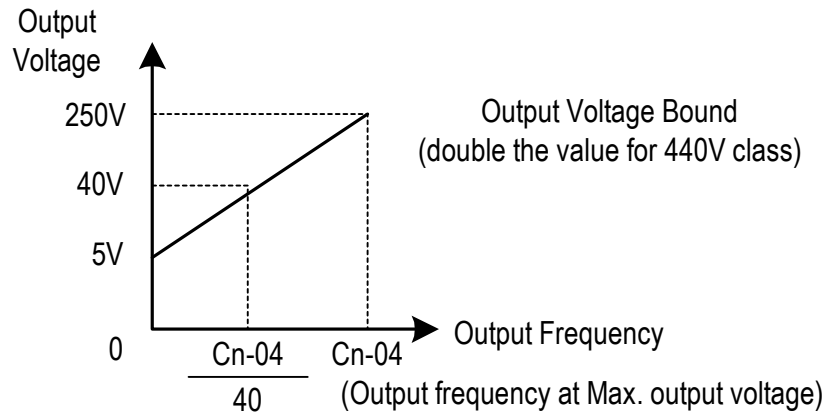

Fig. 33. Output voltage limit

(17) Stall Prevention Selection During Acceleration (Sn-14)

Sn-14 = 0 : Disabled (Accelerate according to the setting. Stall may occurs with large load)

= 1 : Enabled (Stop acceleration if Cn-25 setting is exceeded. Accelerate again when current recovers)

- Please refer to “Stall prevention level during acceleration” on page 3-20.

(18) Stall Prevention Selection During Deceleration (Sn-15)

- If external braking resistor unit is installed, the Sn-15 setting must be disabled (Sn-15= 0).
- If no external braking resistor unit is installed, the inverter can provide about 20% regenerative braking torque. If the load inertia is so large that it exceeds the regenerative braking torque, the parameter Sn-15 is set as “1”. When setting Sn-15= 1 (enabled) is selected, the deceleration time (Bn-02 or Bn-04) is extended so that a main circuit overvoltage does not occur.

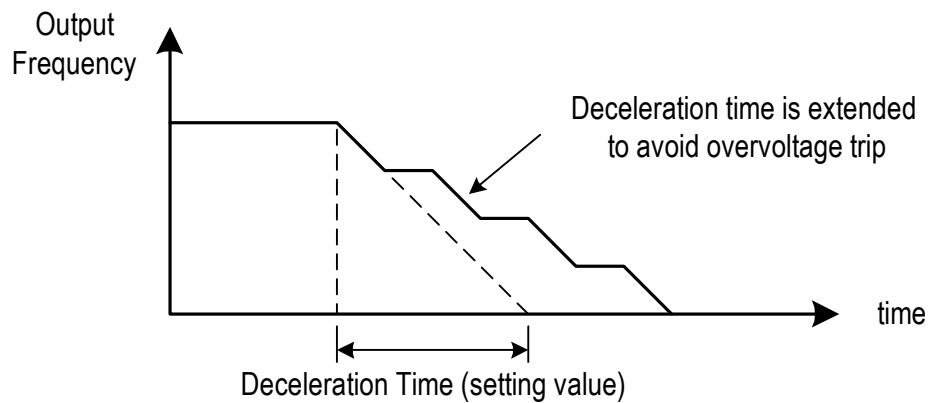

Fig. 34. Stall prevention function during deceleration (Sn-15= 1)

(19) Stall Prevention Selection during Running (Sn-16)

Sn-16 = 0 : Disabled (Stall may occur when a large load is applied)

= 1 : Enabled (Deceleration will start if the motor current is larger than the stall prevention level during running and continues for more than 100ms. The motor is accelerated back to the reference frequency again when the current falls below this level Cn-26).

- Please refer to “Stall prevention level during running” on page 3-20.

(20) Operation Selection at Fault Contact during Fault Retrying (Sn-17)

Sn-17 = 0 : Do not output fault restart. (The fault contact does not work)

= 1 : Output fault restart. (The fault contact operates)

- Please refer to “Number of auto restart attempt” on page 3-19.

(21) Operation Selection at Power Loss (Sn-18)

- This parameter specifies the processing to be performed when a momentary power loss occurs (within 2 sec)

Sn-18 = 0 : When power loss ride through is enabled, operation will be restarted after a speed search invoked if the power is restored within the allowed time.

= 1 : When power loss ride-through is disabled the inverter will stop after a momentary power loss. An undervoltage fault will be detected then. If the power is interrupted for more than 2 seconds, the fault contact output will operate and the motor will coast to stop.

(22) Zero Speed Braking Selection (Sn-19)

- The run-source and frequency command is input from control circuit under the setting of Sn-04=1 & Sn-05=1, If Sn-19 is enabled, the blocking torque will be generated in DC-braking mode when the frequency command is 0V and forward –run source is “ON”.

- A time-chart shows the above action as below. The zero-braking selection Sn-19 is set to 1 and the DC-braking current Cn-15 is limited within 20% of rated current.

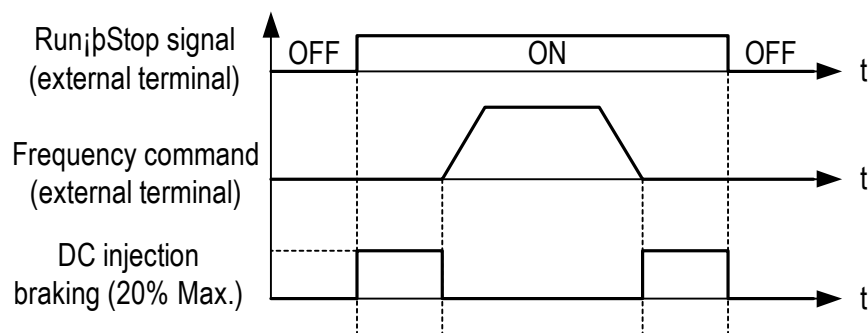

Fig. 35. Zero speed braking operation selection

- (23) External Fault Contact ③ Contact Selection (Sn-20)  
Sn-20 = 0 : Input signal is from A-contact. (Normal-open contact)  
= 1 : Input signal is from B-contact. (Normal-close contact)
- (24) External Fault Contact ③ Detection Selection (Sn-21)  
Sn-21 = 0 : Always detects.  
= 1 : Detect only during running.
- (25) Detection Mode Selection of External Fault (Sn-22)
- An external fault is detected (at terminal ③), the following operation will be performed based upon the setting of Sn-22  
Sn-22 = 0 : Decelerate to stop with the specified deceleration time Bn-02.  
= 1 : Coast to stop.  
= 2 : Decelerate to stop with the specified deceleration time Bn-04.  
= 3 : Continue running with no regard of external fault.
- (26) Motor Overload Protection Selection (Sn-23)
- Sn-23 = 0 : Electronic overload protection disable.  
Sn-23 = 1~4 : Electronic overload protection enabled. The electronic thermal overload is detected according to the characteristic curves of protection operating time. vs. motor rated current setting (Cn-09).  
Sn-23 = 1 : The overload is detected according to the standard motor cold start curve.  
= 2 : The overload is detected according to the standard motor hot start curve.  
= 3 : The overload is detected according to the specific motor cold start curve.  
= 4 : The overload is detected according to the specific motor hot start curve.
- Disable the motor protection function (setting 0) when 2 or more motors are connected to a single inverter. Use another method to provide overload protection separately to each motor, such as connecting a thermal overload relay to the power line of each motor.
  - The motor overload protection function should be set as Sn-23= 2 or 4 (hot start protection characteristic curve) when the power supply is turned on or off frequently, because the thermal values is reset each time when the power is turned off.
  - For the motor without forced cooling fan, the heat dissipation capability is lower when in the low speed operation. The setting Sn-23 can be either '1' or '2'.
  - For the motor with forced cooling fan, the heat dissipation capability is not dependent upon the rotating speed. The setting Sn-23 can be either '3' or '4'.
  - To protect the motor from overload by use of electronic overload protection, be sure to set the parameter Cn-09 according to the rated current value shown on the motor nameplate.

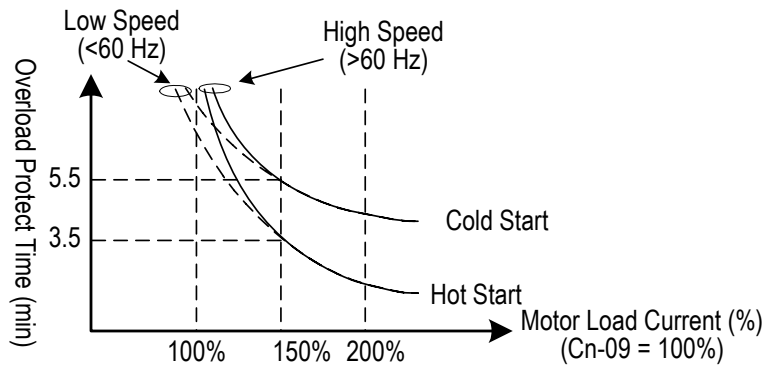

Fig. 36. Motor overload protection curve (Cn-09 setting = 100%)

(27) Frequency Characteristics Command Selection at External Analog Input Terminal (Sn-24)

Sn-24 = 0 : Frequency command is input at VIN terminal (0~10V)

= 1 : Frequency command is input at AIN terminal (4~20mA)

= 2 : Frequency command is the addition (VIN + AIN) at VIN (0~10V) and AIN (4~20mA) terminal.

= 3 : Frequency command is the combination (VIN - AIN) at VIN (0~10V) and AIN (4~20mA) terminal. If the value (VIN - AIN) is negative, the reference command will take '0' as a result.

- On inverter with 4P101C01301 control board, if Sn-68 = -1 and Sn-05 = 1 VIN allowing input  $\pm 10V$ , set Sn-24 to select main frequency:

Sn-24 = 0 : frequency command is controlled by VIN(-10~+10V) input.

(Corresponding main frequency: -10V ~ +10V → Reverse frequency 100% ~ forward frequency 100%)

= 1 : frequency command in controlled by AIN(4~20mA) input.

(the status of forward/ reverse is set by user)

= 2 : frequency command is controlled by VIN and AIN, the sum of both (VIN + AIN).

= 3 : frequency command is controlled by VIN and AIN, the balance of both (VIN - AIN).

(When (VIN + AIN) < 0 or (VIN - AIN) < 0, main frequency switched to reverse status.

Sn-24 = 0、2、3, forward or reverse is control by main frequency command polar.

(28) Multi-Function Input Terminal ⑤ Function Selection (Sn-25)

(29) Multi-Function Input Terminal ⑥ Function Selection (Sn-26)

(30) Multi-Function Input Terminal ⑦ Function Selection (Sn-27)

(31) Multi-Function Input Terminal ⑧ Function Selection (Sn-28)

- The settings and functions for the multi-function input are listed in Table 14.

Table 14 Multi-Function Input Setting

Setting	Function	LCD Display	Description
00	Forward/Reverse command	3_Wire Run	3-wire operation mode
01	2-wire key-pressing input stop command	2_Wire Stop Key	2-wire operation mode
02	Multi-speed command 1	Multi-Fun. Command 1	Multi-speed frequency command selection
03	Multi-speed command 2	Multi-Fun. Command 2	
04	Multi-speed command 3	Multi-Fun. Command 3	
05	Multi-speed command 4	Multi-Fun. Command 4	
06	Jogging	Jog Command	ON: select jogging frequency
07	Acc/Dec time switch command	Acc.&Dec. Switch	OFF: the first stage Acc/Dec time (Bn-01, Bn-02), ON: the second stage Acc/Dec time (Bn-03, Bn-04),
08	External base-block command A-contact)	Ext.B.B. NO_Cont	ON: inverter output baseblock
09	External base-block command (B-contact)	Ext.B.B. NC_Cont	OFF: inverter output baseblock
10	Inhibit Acc/Dec command	Inhibit Acc&Dec	Inhibit Acc/Dec (hold frequency)
11	Inverter overheat warning	Over Heat Alarm	ON: blink show overheat (inverter can proceed running)
12	FJOG	Forward Jog	ON: forward jog
13	RJOG	Reverse Jog	ON: reverse jog
14	PID integration reset	I_Time Reset	ON: Reset PID integration
15	PID control invalid	PID Invalid	ON: PID control not effective
16	External fault (A-contact)	Ext.Fault NO_Cont	ON: External fault input (normally open)
17	External fault (B-contact)	Ext.Fault NC_Cont	OFF: External fault input (normally close)
18	Multi-function analog input	~ Input Valid	ON: multi-function analog input (AUX) effective
19	Timer function input	Timer Function	ON: ON-delay/OFF-delay timer input
20	DC braking command	DC Brakin Command	ON: DC injection braking applied when the frequency output is less than the DC injection start frequency
21	Speed search 1 command	Max Freq. Sp_Search	ON: speed search is performed from max. output frequency
22	Speed search 2 command	Set Freq. Sp_Search	ON: speed search is performed from reference frequency
23	Local/Remote control I	Operator Control	ON: local mode control (through LCD operator) OFF: Run Source and Frequency Command is determined according to (Sn-04, Sn-05) setting
24	Local/Remote control II	Ext. Term. Control	ON: local mode control (through control circuit terminal) OFF: Run Source and Frequency Command is determined according to (Sn-04, Sn-05) setting
25	RS-485 communication application	Comm. Control	PLC application extension use. (Please refer to "RS-485 MODBUS/PROFIBUS Application Manual")
26	speed control without PG	PG Invalid	ON: Speed control without PG
27	Reset integration of speed control with PG	I_Time Invalid	ON: Reset integration of speed control with PG
28	Frequency Up/Down function	UP/DOWN Function	Only Sn-28 can be set as Sn-28=28, terminal ⑦ used as up cmd. and terminal ⑧ used as down cmd. when Sn-28=28
29	Force operation signal	Force Run	Only Sn-28 can be set as Sn-28=29

Note: An error message of “Multi-Fun. Parameter” / “Setting Error” will be displayed if:

- Setting combination of (Sn-25~Sn28) is not organized in monotonically increasing order.
- Setting 21, 22 (both for speed search command) are set at the same time.

- Forward/Reverse Change (setting : 00)
- Under 3-wire initialization mode (Sn-03= 8 or 10 or 12) , the multi-function input terminals ⑤~⑧ have setting “00”, the inverter will be in the 3-wire mode operation. As shown in Fig. 37, the Forward/Reverse change mode is set at the terminal ⑤.

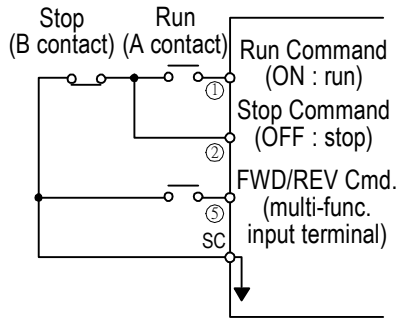

Fig. 37. 3-wire mode connection diagram

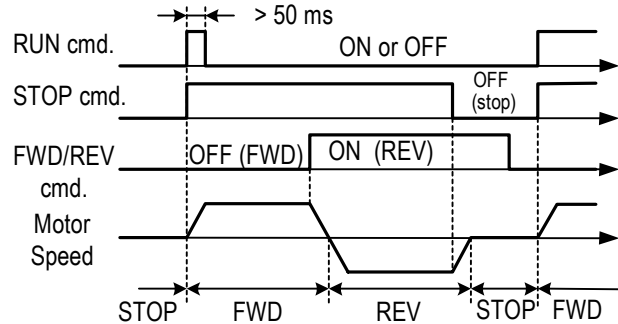
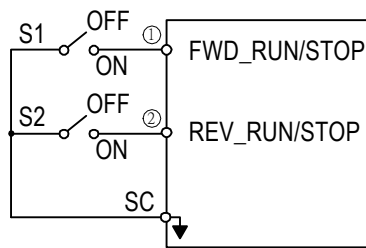
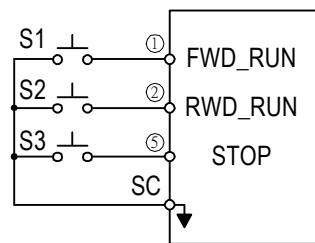

Fig. 38. Operation sequence in 3-wire mode

- Input STOP Command during 2-Wire Mode Operation (setting : 01)
- Under a standard 2-wire initialization mode as shown in Fig. 39(a), S1 and S2 can not be both “ON” at the same time. When S1= “ON” and S2= “OFF”, the motor is FWD running. When S1= ”OFF” and S2= “ON”, the motor is REV running. When S1= “OFF” and S2= “OFF”, the motor stops running.
- When Sn-25= ‘01’, the 2-wire operation mode has its self-sustaining function. Only through the multi-function input terminal⑤, the operator can stop the inverter after pressing the “STOP” key as shown in Fig. 39(b). As shown in Fig. 39(b), the switches S1, S2 and S3 do not need to be the self-sustaining switches. When S1 is depressed “ON”, the motor will be forward running. After S3 is depressed “ON”, the motor will stop. When S2 is depressed “ON”, the motor will be reverse running. After S3 is depressed “ON”, the motor will stop.



(a)



(b)

Fig. 39. 2-wire mode connection diagram

Note : 1. For the other setting value (except “00”, “01”), the external operation mode is defaulted as 2-wire mode and no self-sustaining function. (that is, the inverter will stop when contact ① and ② are not close.) ◦

2. Under the 2-wire mode, the error message “Freq. Comm. Error” will be displayed in the digital operator when terminal ① and ② are both ON at the same time, the inverter will stop. After the above case cleared, the inverter will return normal.

- Multi-Step Speed Command 1 (Setting : 02)
- Multi-Step Speed Command 2 (Setting : 03)
- Multi-Step Speed Command 3 (Setting : 04)
- Multi-Step Speed Command 4 (Setting : 05)
- Jog Frequency Selection (Setting : 06)
- There are 16 (maximum) step speed command selection from the combination of the Multi-Step Speed Command and jog frequency command.
- Multi-Step Speed command 1~4 and Jog Frequency Selection Setting Table.

Terminal ⑧ (Sn-28= 05)	Terminal ⑦ (Sn-27= 04)	Terminal ⑥ (Sn-26= 03)	Terminal ⑤ (Sn-25= 02)	Selected frequency
Multi-step speed cmd. 4	Multi-step speed cmd. 3	Multi-step speed cmd. 2	Multi-step speed cmd. 1	
0	0	0	0	Freq. Cmd. 1 (An-01)*1
0	0	0	1	Freq. Cmd. 2 (An-02)*2
0	0	1	0	Freq. Cmd. 3 (An-03)
0	0	1	1	Freq. Cmd. 4 (An-04)
0	1	0	0	Freq. Cmd. 5 (An-05)
0	1	0	1	Freq. Cmd. 6 (An-06)
0	1	1	0	Freq. Cmd. 7 (An-07)
0	1	1	1	Freq. Cmd. 8 (An-08)
1	1	1	1	Freq. Cmd. 16 (An-16)

Note: “0” : terminal is “OFF”                      “1” : terminal is “ON”

- An example shows the operation sequence of a multi-step speed and jog command is as below.

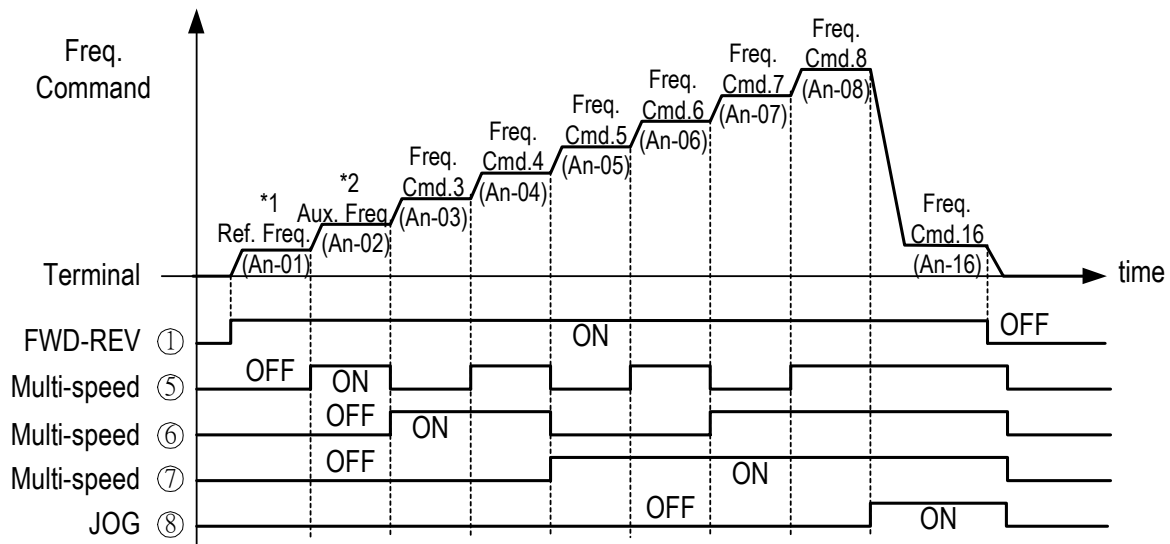

Fig. 40. Time chart for multi-step speed and jog command

- \*1 When the parameter Sn-05= 0, the reference command is input by the setting of An-01. Instead, when the parameter Sn-05= 1, the reference command is input from analog command through the terminal VIN and AIN.
  - \*2 If the parameter Sn-29= 0, the auxiliary frequency (the 2nd step frequency setting: AUX frequency) is input from the AUX terminal. If the parameter Sn-29  $\neq$  0, the 2nd step frequency setting is determined by the parameter of An-02.
- Acceleration Time And Deceleration Time Change (Setting : 07)
    - The acceleration time and deceleration time can be changed through the control circuit terminal ⑤~⑧ as described on page 3-4.
  - External Baseblock (A Contact) (Setting : 08)
  - External Baseblock (B Contact) (Setting : 09)
    - With either of these settings, the multi-function input terminal controls its inverter baseblock operation.
    - During running: As an external baseblock signal is detected, the digital operator will display a “B.B. Alarm”. Then, the inverter output is blocked. After the baseblock signal is cleared, the motor will resume running according to its then reference signal.
    - During deceleration : An external baseblock signal is input, the digital operator will display “ B.B. Alarm”, the inverter is blocked from output and the output frequency will drop to zero. The motor will then coast to stop freely. After this external baseblock signal is cleared, the inverter will stay in stop mode.
  - Acceleration and Deceleration Ramp Hold (Setting : 10)
    - With this setting, the signal of Acceleration/deceleration ramp hold (input from the multi-function input terminals) will pause the Acceleration/deceleration of motor and maintain the then output frequency. The motor will coast to stop if an OFF command is input while the acceleration / deceleration ramp hold input is ON, the then output frequency will be memorized and the command of Acceleration/deceleration ramp hold is released.

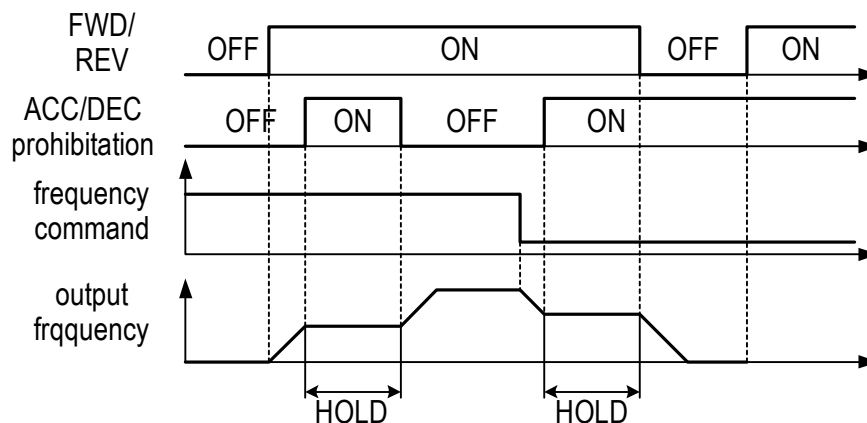

Fig. 41. Acceleration and deceleration ramp hold

- Inverter Overheat Alarm (Setting : 11)
  - When the inverter detects a overheat signal “ON”, the digital operator will change its display as “Overheat Alarm”. And the inverter still maintains its operation. When the overheat signal is “OFF”, the digital operator will restore its previous display automatically. No RESET-key pressing is required.
- FJOG Command (Setting : 12)
- RJOG Command (Setting : 13)
  - The jogging can be performed in forward or reverse rotation.  
 Setting = 12: FJOG command “ON”: Run forward at the jog frequency (An-17).  
 = 13: RJOG command “ON”: Run reverse at the jog frequency (An-17).
  - The forward jog and reverse jog commands have priority over other frequency command commands.
  - The inverter will stop running with the stopping method set by the setting of Sn-06 if the forward jog and reverse jog commands are both ON for more than 500 ms.
- PID Integral Reset (Setting : 14)
  - In the application of PID control, the integral can be reset to zero (ground) through the multi-function input terminal ⑤~⑧ (Sn-25~28= 14).

- PID Control Invalid (Setting : 15)

OFF	PID control valid (close-loop)
ON	PID control invalid (open-loop)

- This setting can be used in the changeover of test run. To disable the PID function (PID control invalid is “ON”) , an open-loop operation or jog operation can be performed in the test. The system can be set up properly after some test runs. Then, the system can be changed into PID control mode. Moreover, if the feedback signal is not usable, the PID function is disabled through this setting.
- The setting of Sn-64 can be used to enable or disable the PID function.
- External Fault Contact A (Setting : 16)
- External Fault Contact B (Setting : 17)
  - The external fault input terminal is set to “ON”, an external fault then occurs. If the external input terminal ⑥ is set for the external fault input terminal use, a message of “Fault Ext. Fault 6” will be displayed.
  - There are 5 terminal to be assigned as external fault inputs, they are terminal ③, ⑤, ⑥, ⑦, ⑧
  - When an external fault occurs, the inverter will be blocked from output and the motor will coast to stop.

- Multi-Function Analog Input Setting (Setting : 18)
  - To disable or enable the multi-function analog input at AUX terminal is controlled by the input signal at an external terminal. When the PID function is enabled, the original AUX function will be disabled.
- Timer Function Input Terminal (Setting : 19)
  - Refer to the setting of timer function output terminal on page 3-66.
- DC Injection Braking Command (Setting : 20)
  - DC injection braking is used to prevent the motor from rotating due to inertia or external forces when the inverter is stopped.
  - The DC injection braking will be performed and the inverter will be stopped if the DC injection braking input is ON.

If a run source or jog command is input, the DC injection braking will be cleared and the motor will begin to run.

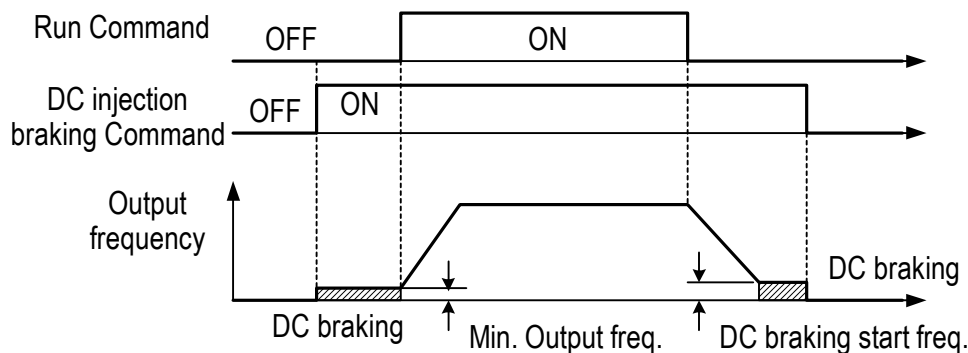

Fig. 42. Time chart for DC injection braking command

- Speed Search 1 (Setting : 21)
- Speed Search 2 (Setting : 22)
  - Refer to 'speed search' function on page 3-24.
- LOCAL/REMOTE Control 1 (setting : 23)

OFF	Remote Control Run command and frequency command is performed through control circuit input or RS-485 communication port. (It will be set by the combination of settings of Sn-04 and Sn-05.) The REMOTE-REF , SEQ LED light is ON.
ON	Local Control Run command and frequency command is performed through digital operator. The REMOTE-REF , SEQ LED light is OFF.

- To change the operation mode from LOCAL to REMOTE mode is effective only when the inverter is in STOP mode.

- LOCAL/REMOTE Control 2 (setting : 24)

OFF	Remote Control Run command and frequency command is performed through control circuit input or RS-485 communication port. (It will be set by the combination of settings of Sn-04 and Sn-05.) The REMOTE-REF , SEQ LED light is ON.
ON	Local Control Run command and frequency command is performed through control circuit terminal. The REMOTE-REF , SEQ LED light is OFF.

- To change the operation mode from LOCAL to REMOTE mode is effective only when the inverter is in STOP mode.
- RS-485 Communication Application (Setting : 25)
  - The multi-function input terminals ⑤ ~ ⑧ can be used as the extension contact terminals of PLC with the command communicated through the RS-485 port. (Please refer to the “RS-485 MODBUS/PROFIBUS APPLICATION MANUAL”)
- PG-Less Speed Control Action (Setting : 26)
- Reset Integration of Speed Control with PG (Setting : 27)
  - When PG feedback is used, the integral control (to add the PG feedback compensation) can be disabled or enabled from the external terminals. And, user can use the external terminals to clear the integral value.

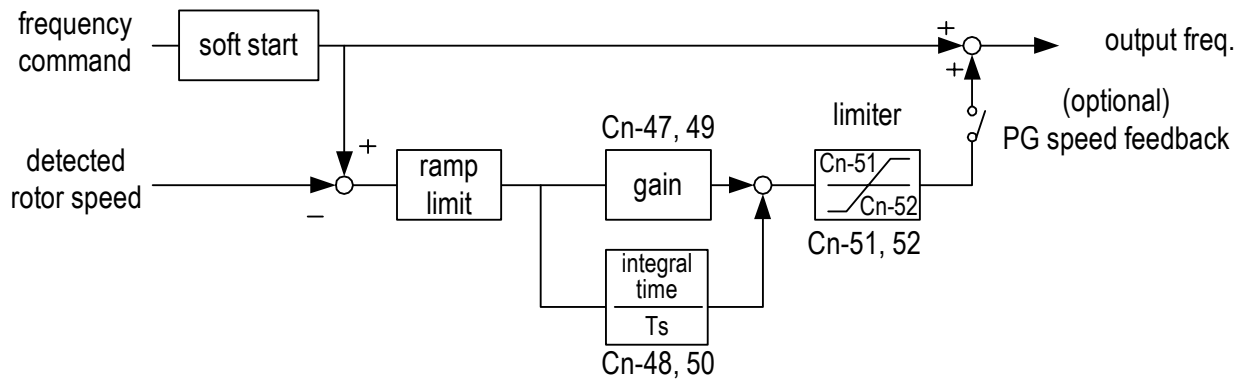

Fig. 43. PG speed control block diagram

- Frequency UP/DOWN Function (Setting : 28)
  - The inverter can use either the digital operator or external multi-function input terminals (terminal ⑦ or ⑧) to change the output frequency upward or downward.
  - By setting the parameters of (Sn-04= 1 , Sn-05= 1), firstly the run source and frequency command is set through the control circuit terminals. Secondly, set the parameter Sn-28 = 28 (terminal ⑦ will now have the function “UP”, its original function is disabled). Then, terminal ⑦ and ⑧ can be used for “UP” and “DOWN” function to control /change the output frequency.
  - Operation sequence as below:

Control circuit terminal ⑦ : UP function	ON	OFF	OFF	ON
Control circuit terminal ⑧ : DOWN function	OFF	ON	OFF	ON
Operation status	ACC (UP)	DEC (DOWN)	Constant (HOLD)	Constant (HOLD)

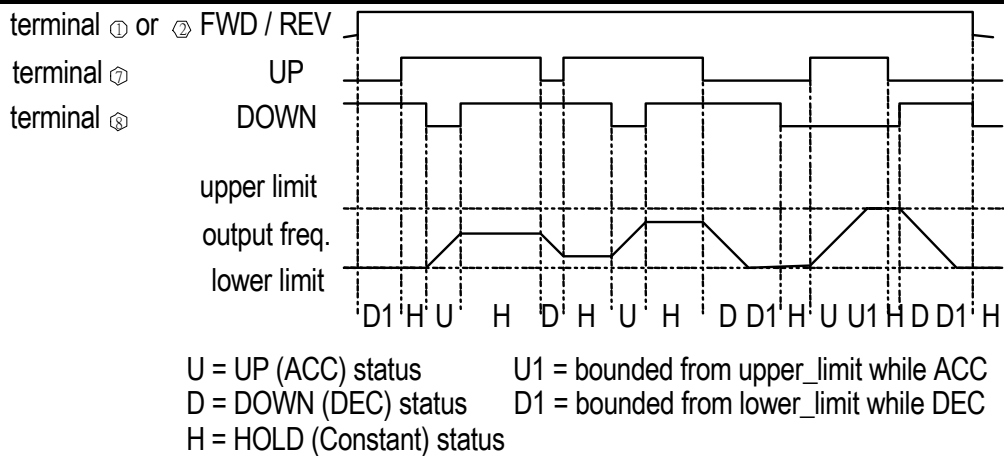

Fig. 44. Time chart of output frequency with the UP/DOWN function

- Only set through parameter Sn-28
  - When the frequency UP/DOWN function is being used, the output frequency will accelerate to the lower\_limit (Cn-19) if a run command is pressed.
  - If under HOLD state, 4th bit of Sn-68 is set to 1 power supply OFF, the inverter can remember output frequency as power supply OFF. When resupplying the power and operation command ON, the inverter will run at the remembered output frequency.
  - Under auto operation mode, UP/DOWN operation is unavailable.
  - When the UP/DOWN function and jog frequency command are both assigned to multi-function inputs, the jog frequency command input has the highest priority.
  - Under UP/DOWN operation, PID is unavailable.
- Forced Run (Setting : 29)
    - Only set through parameter Sn-28. It is for special use (smoke fan, etc.)

### (32) Multi-Function Analog Input Function Selection (Sn-29)

- The settings and functions for the multi-function analog input (terminal AUX) are listed in Table 15.

Table 15 Multi-function analog input function list

Setting	Function	LCD Display	Description (100% output corresponds to 10 V level)
00	Auxiliary frequency command	Auxiliary Freq.Cmd.	(Max. output frequency)
01	Frequency command gain (FGAIN)	Instruction gain 1	Total gain = (Bn-05, Bn-07) × FGAIN
02	Frequency command bias 1 (FBIAS1)	Cmd. Bias 1	Total bias = (Bn-06, Bn-08) + FBIAS1
03	Frequency command bias 2 (FBIAS2)	Cmd. Bias 2	Total bias = (Bn-06, Bn-08) + FBIAS2
04	Torque detection level 1	Tq. Detect Level 1	According to analog input voltage (0~10V), change torque detection 1 level (setting of Cn-32 is disabled)
04	Overtorque detection level	Over Tq. Level	According to analog input voltage (0~10V), change overtorque detection level (setting of Cn-32 is disabled)
05	Output frequency bias (VBIAS)	Output Voltage	Total output voltage= V/F pattern voltage + VBIAS
06	Scaling of ACC/DEC time(TK)	Acc&Dec Coeff	Real ACC/DEC time= ACC/DEC time (Bn-0~24) / TK
07	DC injection braking	DC Brakin current	According to analog input voltage (0~10V), change the level of DC injection current (0-100%). (inverter rated current=100%, the setting of DC injection current Cn-15 is disabled )
08	Stall prevention level during running	Run Still Level	According to analog input voltage (1.5V~10V), change the level of stall prevention during running (30%~200%) (inverter rated current=100%, the setting Cn-26 is disabled.)
09	PID control reference input	PID Command	Multi-function analog input (terminal AUX) used as PID control reference input (0~10V). Please refer to "PID CONTROL BLOCK DIAGRAM" on page 3-7.
10	Frequency command lower limit	Freq. Cmd. Low Bound	Change the frequency command lower-limit (0-100%) value according to the then analog input voltage (0~10V) (Max. output frequency (Cn-02) corresponds to the 100% analog output. The actual lower-limit is determined by the maximum of Cn-19 and the value corresponding to the multi-function analog input terminal).
11	Jump frequency setting4	Freq Jump 4	Set the jump frequency 4, according to analog input voltage (0~10V), while Cn-20~Cn-23 can be used to set the jump frequency 1~3 and their jump frequency width.

12	RS-485 communication application	Comm. Control	The analog value of AUX (0-1024/0-10V) can be read through RS-485 communication.
13	Frequency instruction gain 2 (FGAIN) *1	Instruction gain2	With Bn-05, 06 (or Bn-07, 08) set, adjust analog frequency instruction gain and bias ( gain and bias adjustment is similar to 7200GA)
14	Frequency instruction bias3 (FBIAS1) *1	Instruction bias 3	
15	Frequency instruction bias 4 (FBIAS2) *1	Instruction bias 4	
16	Torque detection level 2 (for 74.03 and later software version only)	Tq. Detect Level 2	According to analog input voltage (0~10V), change torque detection 2 level (setting of Cn-62 is disabled)

\*1: 30.14 later version software will provide such function.

- Analog input AUX can provided two groups of gain and bias as Sn-29 = 1~3 and 13-15. When Sn-29 = 13~15, the adjustment of gain and bias is similar to GA series. The following is the block diagrams: (Following is new diagram)

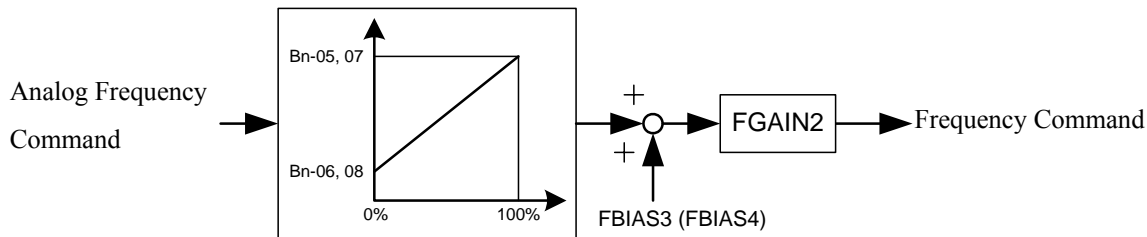
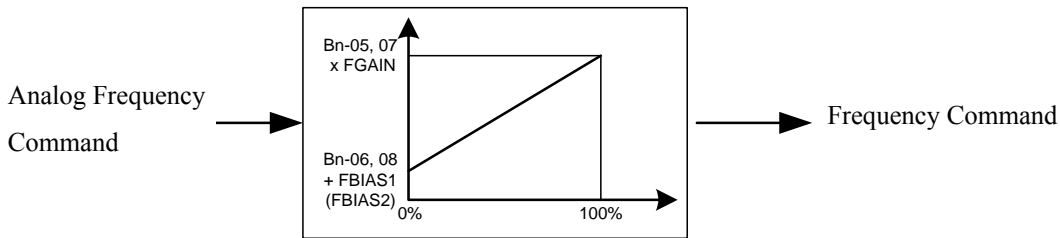

• Multi-function analog input characteristics

(1) Sn-29 = 00

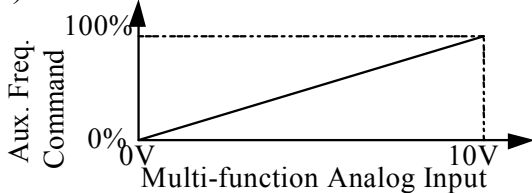

(2) Sn-29 = 01,13

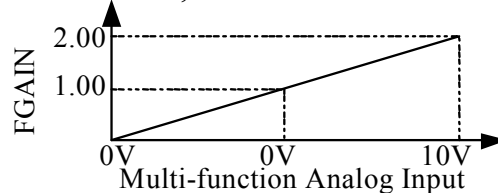

(3) Sn-29 = 02,14

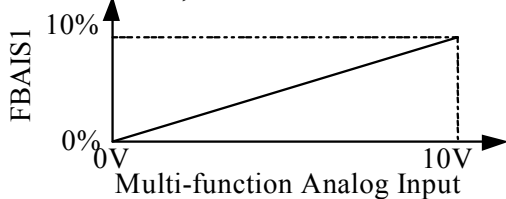

(4) Sn-29 = 03,15

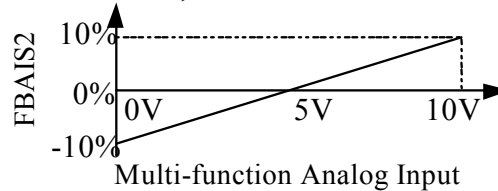

(5) Sn-29 = 04,16

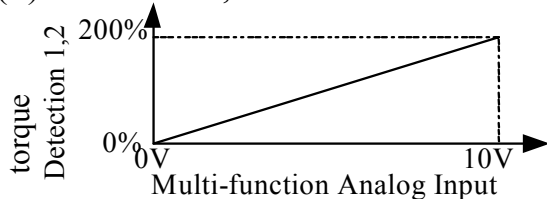

(6) Sn-29 = 05

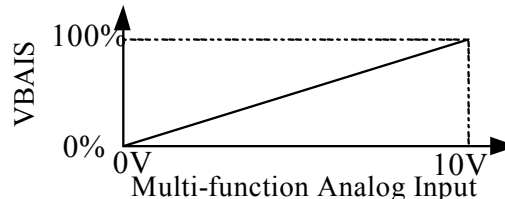

(7) Sn-29 = 06

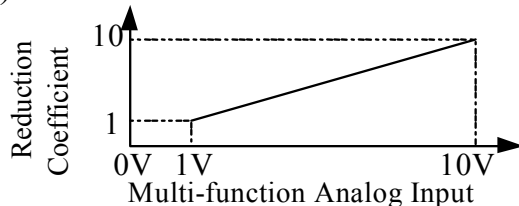

(8) Sn-29 = 07

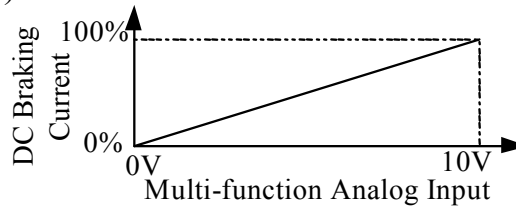

$$\text{Real ACC/DEC Time} = \frac{\text{ACC/DEC Time (Bn-01~04)}}{\text{Reduction Coefficient (TK)}}$$

(9) Sn-29 = 08

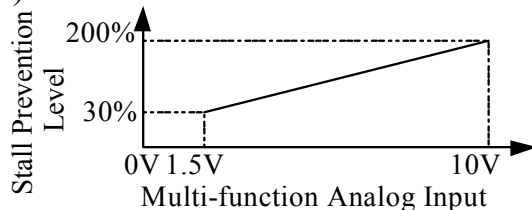

(10) Sn-29 = 09

Multi-function analog input (terminal AUX) used as PID control reference input (0~10V). Please refer to "PID CONTROL BLOCK DIAGRAM" on page 3-9 and App-3.

(11) Sn-29 = 10

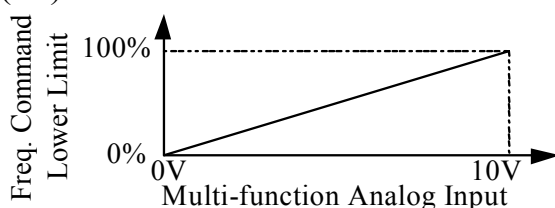

(12) Sn-29 = 11

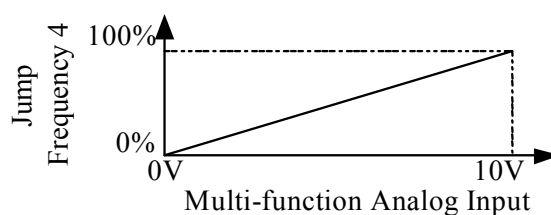

(13) Sn-29=12 : For RS-485 communication use. The analog value of AUX (0-1024/0-10V) can be read through RS-485 communication. (Please refer to 'RS-485 MODBUS/PROFIBUS Application Manual')

- (14) Multi-Function Output Terminal (RA-RB-RC or R1A-R1B-R1C) Function Selection (Sn-30)
- (15) Multi-Function Output Terminal (DO1-DOG) Function Selection (Sn-31)
- (16) Multi-Function Output Terminal (DO2-DOG or R2A-R2C) Function Selection (Sn-32)

Multi-function output terminal setting and its function as shown in Table 16.

Table 16 Multi-function output terminal function

Setting	Function	LCD Display	Description
00	During running	Running	ON : During running
01	Zero speed	Zero Speed	ON : Zero speed
02	Frequency agree	Frequency Arrive	Speed agree width: Cn-31
03	Setting frequency agree	Agreed F Arrive	ON : output frequency = $\pm$ Cn-29, Speed agree width: Cn-31
04	Output frequency detection1	Freq. Det. 1	ON : while ACC, -Cn-29 <input type="checkbox"/> output freq. <input type="checkbox"/> Cn-29 while DEC, -Cn-30 <input type="checkbox"/> output freq. <input type="checkbox"/> Cn-30 Speed agree width: Cn-31
05	Output frequency detection2	Freq. Det. 2	ON : while ACC, output freq <input type="checkbox"/> Cn-29(or <input type="checkbox"/> -Cn-29) while DEC, output freq <input type="checkbox"/> Cn-30(or <input type="checkbox"/> -Cn-30) Speed agree width: Cn-31
06	Inverter ready	Run Ready OK!	ON : READY
07	Undervoltage detected	Low Volt Detect	ON : Undervoltage detected
08	Output baseblocked	Output B.B.	ON : Output baseblocked
09	Run source mode	Run Source Operator	ON : Run source from digital operator (Local mode)
10	Frequency command mode	Ref. Cmd. Operator	ON : Frequency command from digital operator (Local mode)
11	Torque Detection 1, Contact A	Tq. Detect 1 NO_Cont	ON : Torque detection 1 detected, (Contact A)
12	Frequency command Invalid	Freq. Cmd. Invalid	ON : Frequency command Invalid
13	Fault	Fault	ON : Fault
14	Pulse signal output	Pulse Mul. Output	Only set by Sn-31, Sn-32 (terminal DO1-DOG)
15	Undervoltage alarm	Low Volt Alarm	ON : Undervoltage alarm
16	Inverter overheat	Inverter Over Heat	ON : Inverter Overheat
17	Motor overload	Motor Over Load	ON : Motor Overload
18	Inverter Overload	Inverter Over Load	ON : Inverter Overload
19	Fault retry	Fault Retry	ON : Retry
20	RS-485 communication fault	RS-485 Fault	ON : RS-485 communication fault
21	Timer function output	Timer Function	Signal delay output (.vs. timer function input)
22	RS-485 Communication Application	Comm. Control	Extension Output Contact application (Please refer to MA7200 RS-485 MODBUS /PROFIBUS Application Manual')
23	Torque Detection 1, Contact B	Tq. Detect 1 NC_Cont	ON : Torque detection 1 detected, (Contact B)
24	Torque Detection 2, Contact A	Tq. Detect 2 NO_Cont	ON : Torque detection 2 detected, (Contact A)
25	Torque Detection 2, Contact B	Tq. Detect 2 NC_Cont	ON : Torque detection 2 detected, (Contact B)

- During Running (Setting:00)

OFF	Run source OFF, inverter is off.
ON	Run source ON, or Run source OFF but residues output exists

- Zero Speed (Setting : 01)

OFF	Output frequency $\geq$ MIN. output frequency (Cn-07)
ON	Output frequency $<$ MIN. output frequency (Cn-07)

- Frequency Agree : (Setting : 02)
- Setting Frequency Agree : (Setting : 03)
- Output Frequency Detected 1 : (Setting : 04)
- Output Frequency Detected 2 : (Setting : 05)
  - Refer frequency detection function on page 3-22.
- Inverter Ready (Setting : 06)
- Undervoltage Detected (Setting : 07)
  - When the DC link voltage of main circuit is lower than the UNDERVOLTAGE DETECTION LEVEL (Cn-39), the output contact is in 'ON' state.
- Output Blocked (Setting : 08)
- Run Command Mode (Setting : 09)

OFF	Remote Mode (Sn-04 = 1,2, or multi-function input terminal ⑤~⑧ is set as Local/remote control I mode or Local/remote control II mode and contact terminal is OFF). Remote-SEQ LED is light in LCD digital operator
ON	Local Mode (Sn-04 = 0 multi-function input terminal ⑤~⑧ is set as Local/remote control I mode and contact terminal is ON).Remote-SEQ LCD is OFF, run command is from LCD digital operator

- Frequency Command Mode (Setting : 10)

OFF	Remote mode (Sn-05 = 1,2 , or multi- function input terminal ⑤~⑧ is set as Local/remote control I mode or Local/remote control II mode and contact terminal is OFF). Remote-REF LED is light in LCD digital operator
ON	Local mode (Sn-05 = 0 multi- function input terminal ⑤~⑧ is set as Local/remote control I mode and contact terminal is ON). Remote-REF LED is OFF, run command is from LCD digital operator

- Overtorque Detected (Setting : 11)
  - See page 3-23,3-47 for torque detection function.
- Frequency Command Missing (Setting : 12)
  - Run source is ON and frequency command is 0, the output at the multi-function output terminal is ON.
- Fault (Setting : 13)
  - If a fault occurs, the multi-function output terminal is ON. However, no response will occur if a communication fault occurs.
- Pulse Signal Output (Setting : 14)
  - Only multi-function output terminal DO1-DOG (Setting Sn-31) can be set as the pulse signal output.
  - DO1 is a photo-coupler output, its pulse output frequency is set by parameter Sn-35.
  - Its wiring is:

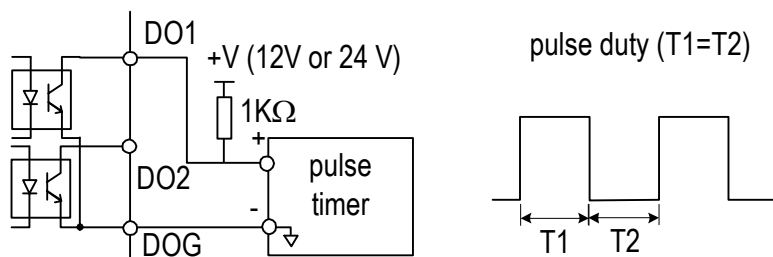

Fig. 45. Pulse signal output

- Undervoltage Alarm (Setting : 15)
  - If the main circuit DC bus voltage is below the undervoltage alarm detected level, the multi-function output terminal is ON.
  - Undervoltage alarm detected level :      230V Class : 240VDC  
460V Class : 460VDC
- Inverter Overheat (Setting : 16)
  - See Page 4-2. If the cooling fin is overheat, the multi-function output terminal is ON.
- Motor Overload (Setting : 17)
  - See “Motor overload protection selection” on page 3-50. If the motor has overload fault, the multi-function output terminal is ON.
- Inverter Overload OL2 (Setting : 18)
  - If the inverter has overload fault, the multi-function output terminal is ON. See page 4-2.

- Fault Retry (Setting : 19)
  - See “Fault restart function” (Cn-24) on page 3-19. Upon restart, the multi-function output terminal is ON.
- RS-485 Communication Fault (Setting : 20)
  - See page 4-2.
- Timer Function Output (Setting : 21)
  - If the multi-function input terminals ⑤~⑧ are set as the timer input terminals (Sn-25 - 28 = 19), the signal will be output through the corresponding multi-function output terminals with the specified ON-delay and OFF-delay, as shown below. See “Timer function” on page 3-9.

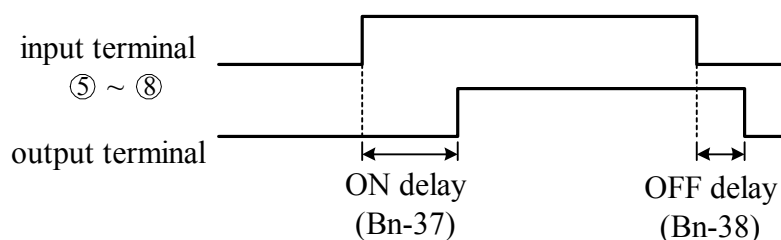

Fig. 46. The input/output signal in ‘Timer’ function application

- RS-485 Communication Application (Setting : 22)
  - In the application that the control commands are executed through the RS-485 communication port, the multi-function output terminals can be used as the PLC Extension Output Contact Terminals. For more details, Please refer to ‘RS-485 MODBUS/PROFIBUS Application Manual’.
- Torque Detection 1, Contact B (Setting : 23)
- Torque Detection 2, Contact A (Setting : 24)
- Torque Detection 2, Contact B (Setting : 25)
  - These settings are available for 74.03 and later software version only.
  - See page 3-23, 3-47 for torque detection function.

(33) Multi-Function Analog Output (Terminal AO1) Selection (Sn-33)

(34) Multi-Function Analog Output (Terminal AO2) Selection (Sn-34)

- The multi-function analog output can be set to monitor the following 12 status items as shown below :

Sn-33, Sn-34 Setting	Monitored contents	Description	
		Input	Output
00	Frequency Command	0 ~ max. frequency	0~10V
01	Output Frequency	0 ~ max. frequency	
02	Output Current	0 ~ rated current	
03	Output Voltage	0 ~ rated voltage	
04	DC Voltage	230V class 0~400V 460V class 0~800V	
05	VIN Analog Command	0 ~ 10 V	
06	AIN Analog Command	4 ~ 20 mA	
07	AUX Analog Command	0 ~ 10 V	
08	PID Input	0 ~ max frequency	
09	PID Output1	0 ~ max frequency	
10	PID Output2	0 ~ max frequency	
11	Comm. Control	0~100%*1	

Note :

\*1: When the setting of Sn-33~34= '11', the multi-function output terminals AO1, AO2 are controlled through RS-485 port either by MODBUS or PROFIBUS protocol. Please refer to "RS-485 MODBUS/PROFIBUS Application Manual"

- The output gain (Bn-14 and Bn-15) will determine the output voltage at multi-function analog output at AO1, AO2 terminal. The specified multiple of 10V will correspond to the 100% output monitored value.

(35) Pulse Output Multiplication-Gain Selection (Sn-35)

- If the multi-function output terminal (DO1) be set as pulse output (when Sn-31 or Sn-32= 14), the final output pulse frequency is the multiple (according to Sn-35) of the inverter output frequency. Refer to Fig. 45 for pulse signal output.
- Ex1: when Sn-35= 0, the inverter output frequency is 60Hz, the output pulse frequency is 60 Hz (duty = 50%).

- Different settings of Sn-35 and their corresponding multiple numbers as shown below :

Sn-35 setting	Pulse output frequency	Applicable freq. range
0	1F : 1 x inverter output frequency	3.83 ~ 400.0Hz
1	6F : 6 x inverter output frequency	2.56 ~ 360.0Hz
2	10F : 10 x inverter output frequency	1.54 ~ 210.0Hz
3	12F : 12 x inverter output frequency	1.28 ~ 180.0Hz
4	36F : 36 x inverter output frequency	0.5 ~ 60.0Hz

(36) Inverter Station Address (Sn-36)

(37) RS-485 Communication Baud Rate Setting (Sn-37)

(38) RS-485 Communication Parity Setting (Sn-38)

(39) RS-485 Stopping Method After Communication Error (Sn-39)

- The MA7200 inverter has a built-in RS-485 port for monitoring inverter status and reading the parameter setting. Under the remote mode operation, the inverter status and the parameter settings can be monitored. Moreover, the user can change the parameters setting to control the motor operation.
- MA7200 will use MODBUS protocol to communicate with external units by means of the cable line form RS-485 port.
- Parameter definition is as follows:
  - Sn-36 : inverter station address, setting range 1~31.
  - Sn-37 = 0: 1200bps (bps: bit / sec)  
= 1: 2400bps  
= 2: 4800bps  
= 3: 9600bps
  - Sn-38 = 0: no parity  
= 1: even parity  
= 2: odd parity
  - Sn-39 = 0: Deceleration to stop with Bn-02 (deceleration time), when RS-485 has communication error.  
= 1: Coast to stop  
= 2: Deceleration to stop with Bn-04 (deceleration time), when RS-485 has communication error.  
= 3: Continue to run (will stop if the key stop is pressed)
- Every data stream has a data length of 11 bits : 1 start bit , 8 data bits , 1 parity bit and 1 stop bit. If Sn-38=0, the parity bit is 1.

- 3 different commands are used for communication between the inverter and external units:
  - a. Read command: external units to read the memory address of the inverter.
  - b. Write command: external units to write the memory address of the inverter in order to control the inverter.
  - c. Circuit test command: To test the communication status between the inverter and external units.
- The change of setting Sn-36, Sn-37, Sn-38 will be effective in the next start time after turning off the inverter.
- Do not make the DRIVE/PRGM changeover while writing the data into the inverter through RS-485 port.
- For more details of RS-485 communication, refer to “RS-485 MODBUS/PROFIBUS Communication Application Manual”.

(40) PG Speed Control Settings (Sn-40)

- Sn-40 = 0 : Disable speed control function.
- = 1 : Enable speed control.
- = 2 : Enable speed control. No integral action during ACC/DEC.
- = 3 : Enable speed control. Integral action is enabled.

(41) Operation Selection at PG Opens (Sn-41)

- Sn-41 = 0 : deceleration to stop (Bn-02)
  - = 1 : coast to stop
  - = 2 : deceleration to stop (Bn-04)
  - = 3 : continue to run
- } Display “PG Open” alarm.  
Blinking display “PG Open” alarm.

(42) Operation Selection at PG Speed Deviation Over (Sn-42)

- Sn-42 = 0 : deceleration to stop (Bn-02)
  - = 1 : coast to stop
  - = 2 : deceleration to stop (Bn-04)
  - = 3 : continue to run
- } Display “Sp. Deviate Over” fault message.  
Blinking display “Sp. Deviate Over” alarm

(43) Overspeed Detection (Sn-43)

- Sn-43 = 0 : deceleration to stop (Bn-02)
  - = 1 : coast to stop
  - = 2 : deceleration to stop (Bn-04)
  - = 3 : continue to run
- } Display “Over Speed” fault message.  
Blinking display “Over Speed” alarm.

(44) Auto\_Run Mode Selection (Sn-44)

(45) Auto\_Run Mode Setting Selection (Sn-45~Sn-60)

- A PLC operation mode is ready to use with the following setting of the multi-step frequency command1~16 (An-01~An-16), Auto\_Run mode time setting (Bn-21~Bn-36) under the auto\_run mode selection (Sn-44). The FWD/REV direction can be set with the setting of Sn45~60.
- Under auto operation mode, to set operation direction by operator, multi-function input terminal or RS-485 are all invalid.
- Under auto operation mode, preset frequency by multifunction input terminal⑤~⑧, and frequency UP/DOWN function is invalid. But if input JOG command as FJOG, RJOG, they will be prior to others. (refer to Sn-25~28) .
- Some example in auto\_run mode :

(A) Single Cycle Running (Sn-44= 1, 4)

The inverter will run for a single full cycle based upon the specified setting mode. Then, it will stop.

For example :

Sn-44 = 1	Sn-45~47=1(FWD)	Sn-48=2(REV)	Sn-49~60=0
An-01 = 15Hz	An-02 = 30Hz	An-03 = 50Hz	An-04 = 20Hz
Bn-21 = 20s	Bn-22 = 25s	Bn-23 = 30s	Bn-24 = 40s
An-05~16 = 0Hz	Bn-25~36 = 0s		

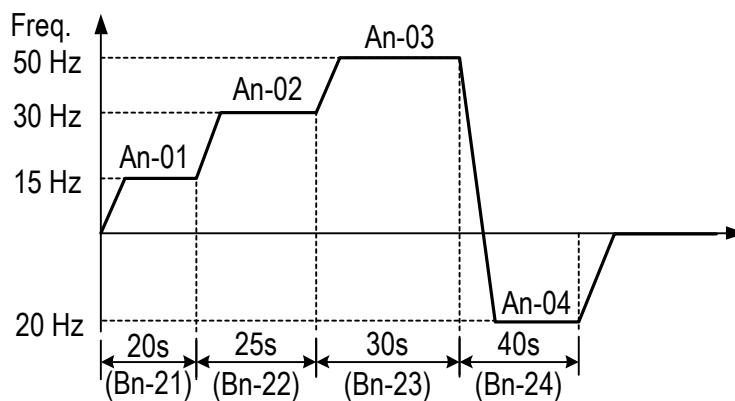

(B) Periodic Running (Sn-44 = 2, 5)

The inverter will repeat the same cycle periodically.

For example :

Sn-44 = 2

An-01 ~ 16, Bn-21 ~ 36, Sn-45-60 : same setting as the example (A)

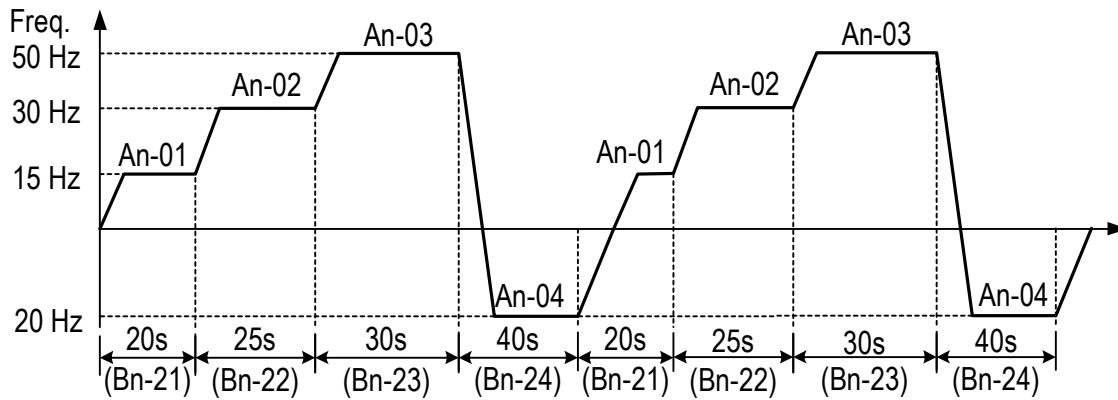

(C) Auto\_Run Mode for Single Cycle

The speed of final step will be held to run.

For example :

Sn-44 = 3

Sn-45~48 = 1 (FWD) Sn-49~60 = 0

An-01~16, Bn-21~36 : same setting as the example (A)

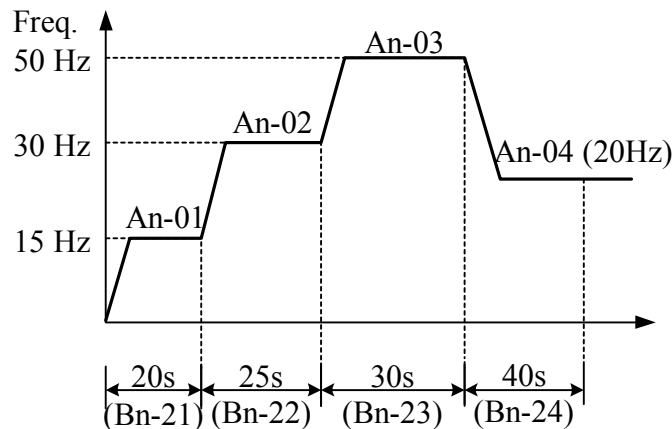

- Sn-44 = 1~3 : If the inverter stops and re-starts again, it will continue running from the unfinished step, according to the setting of Sn-44.
- = 4~6 : If the inverter stops and re-starts again, it will begin a new cycle and continue running according to the setting of Sn-44.

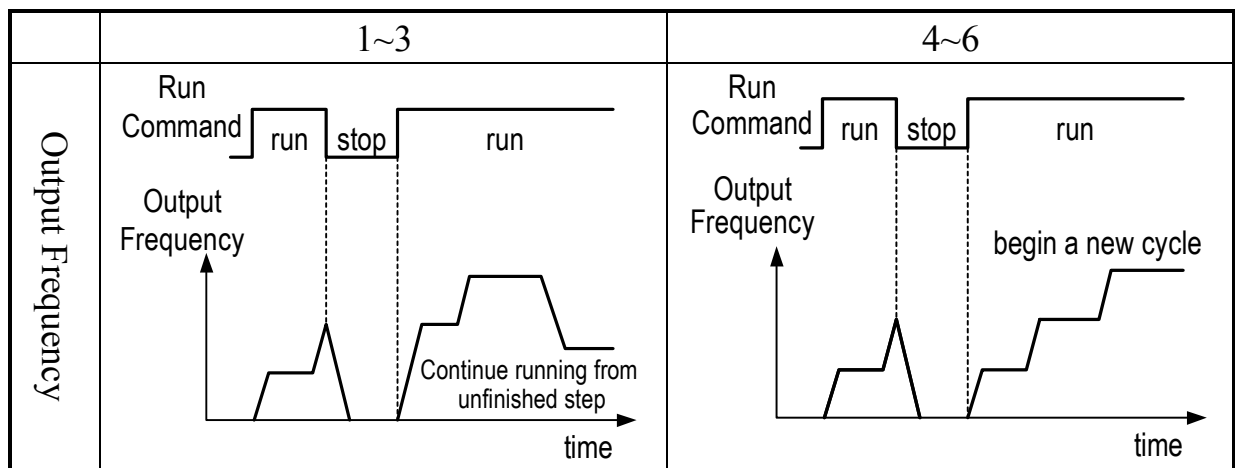

- ACC/DEC time follow the setting of Bn-01, Bn-02 in Auto\_Run Mode.
- If the setting values of Bn-21 ~ Bn-36 are all zero, the Auto\_Run Mode is disabled.

#### (46) Applied Torque Load (Sn-61)

- Select either the constant torque load (Sn-61=0) or varied torque load (Sn-61=1). The inverter will automatically choose the proper V/F pattern and change the inverter overload protection curve. (See page 3-39 for 'INVERTER CAPACITY SELECTION').

#### (47) LCD Language Displayed Selection (Sn-62)

- Sn-62 = 0 : English  
= 1 : Chinese

#### (48) Parameter Copy (Sn-63)

- JNEP-31 LCD digital operator can upload the parameter settings from the LCD digital operator to inverter and download parameter settings from the inverter to the LCD digital operator.
- LCD digital operator will check its EEPROM or the inverter's EEPROM under the following settings.
- Sn-63 = 0 : NO action
  - = 1 : Upload data (LCD digital operator → inverter). During this period, the LED on the LCD digital operator will light sequentially in the CW sense.
  - = 2 : Download data (inverter → LCD digital operator). During this period, the LED on the LCD digital operator will light sequentially in the CCW sense.
  - = 3 : Verification check on LCD's EEPROM; during this period the LED will be switch-on between 2 groups.
  - = 4 : Verification check on inverter's EEPROM; during this period the LED will not light.

- Please follow the below steps to implement the action of parameter copy between different inverters (either upload or download).  
 Step 1: Check the contents of (LCD) digital operator EEPROM (Sn-63='03'), then check the contents of inverter's EEPROM (Sn-63='04'). Make sure that both EEPROM function properly.  
 Step 2: Download and copy the inverter's parameter settings to LCD digital operator EEPROM (Sn-63=2).  
 Step 3: Upload and copy the parameter settings of LCD digital operator to other inverter's EEPROM (Sn-63=1).

(49) PID Function Selection (Sn-64)

- To enable PID control, set Sn-64=1. Otherwise, set Sn-64=0 to disable PID control function. Moreover, it is possible to use the multi-function terminals ⑤~⑧ to enable/disable PID control.

(50) Braking Resistor Protection Selection (Sn-65)

- Sn-65 = 0 : External braking resistor protection invalid  
 = 1 : External braking resistor protection valid
- Whenever the external braking resistor is used, be sure that the parameter 'Sn-65 = 1' is set.

(51) Motor Parameter Autotuning Selection (Sn-66)

- The AUTOTUNE feature can be used to identify and store the motor's parameters
- Sn-66 = 0 : Autotuning Disable  
 = 1 : Autotuning Enable

(52) Control Mode Selection (Sn-67)

- Select one of the two control modes
- Sn-67 = 0 : V/F Control Mode (include V/F control with PG feedback)  
 = 1 : Sensorless Vector Control Mode

<b>Sensorless Control</b>
---------------------------

\*1

1. Set Sn-67 = 1 for sensorless vector control.
2. Set Sn-66 = 1 for autotuning.

\*1. For output frequency less than 1.5Hz in sensorless vector control, set Sn-02=15 and then change Cn-07 to required frequency.

(53) Control selection (Sn-68)

- The set method adopts bit edit, each bit represents one item of function. One bit is set to 0 indicates such function is unavailable, while 1 is available.
- Bit 1(—Y) is corresponding to phase lose protection function. If ON the function, the inverter will stop output when output terminals phase-lose.
- Bit 2(—Y-) is reversed with no function.

- Bit 3(-Y—) is set to allow  $\pm 10V$  analog voltage input. If the bit is set to 1, the analog voltage input terminal ( $V_{in}$ ) can input  $-10V \sim +10V$ . If it is set to 0, the analog input terminal ( $V_{in}$ ) is default as 0V, that is the voltage is less than 0V is not acceptable. Start PID control (Sn-64=1~8), to set the bit, feedback signal  $\pm 10V$  is acceptable. The function on 30.16 later versions and with 4P101C01301 control board is available. The previous version or with not 4P101C01301, the bit is without such function.
- Bit 4(Y—) is set to remember output frequency UP/DOWN function under HOLD state. If the bit is set to 1, to remember the output frequency the latest OFF the inverter. If 0, the function is available. Please refer to Sn-28=28 parameters description for frequency UP/DOWN function

(54) Torque Detection 2 Selection (Sn-69)- See Page 3-47

(55) Engineering Unit (Sn-70)

- The parameter is available for 74.03 and later software version only.
- The inverter supports following engineering unit for frequency command, frequency display and PID feedback display.
- Sn-70 = 0 : NONE
  - 1 : FPM (feet per minute)
  - 2 : CFM (cubic feet per minute)
  - 3 : PSI (pounds per square inch)
  - 4 : GPH (gallons per hour)
  - 5 : GPM (gallons per minute)
  - 6 : in
  - 7 : ft
  - 8 : /s (units per second)
  - 9 : /m (units per minute)
  - 10 : /h (units per hour)
  - 11 : °F
  - 12 : inW (inches in water column)
  - 13 : HP
  - 14 : m/s (meters per second)
  - 15 : MPM (meters per minute)
  - 16 : CMM (cubic meters per minute)
  - 17 : W
  - 18 : kW
  - 19 : m
  - 20 : °C
- The function is enabled while LCD Digital Operator Display (Cn-28) is in the range from 40 to 39999.

### 3.5 Monitoring parameters Un-□□

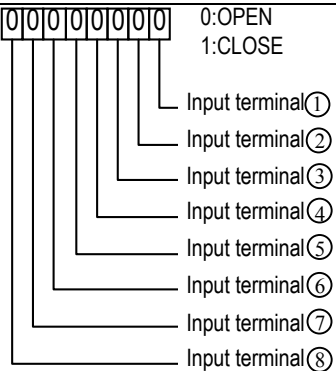
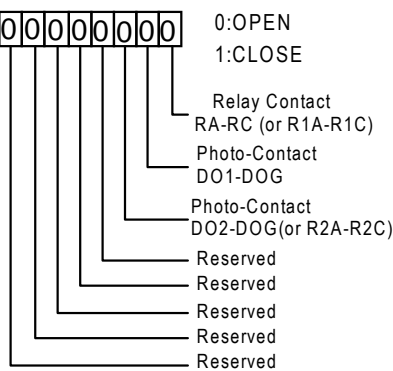
Parameter No.	Name	LCD display (English)	Unit	Description	Multi-function Analog Output Level
Un-01	Frequency Command	Un-01=60.00Hz Frequency Command	0.01Hz	Display frequency command. The displayed unit is determined by Cn-28.	10V/MAX. Output Frequency
Un-02	Output Frequency	Un-02=60.00Hz Output Frequency	0.01Hz	Display output frequency. The displayed unit is determined by Cn-28.	10V/MAX. Output Frequency
Un-03	Output Current	Un-03=12.5A Output current	0.1A	Display inverter output current.	10V/Inverter Rated Current
Un-04	Output Voltage	Un-04=220.0V Output Voltage	0.1V	Display output voltage command of inverter	10V/230V or 10V/460V
Un-05	Main Circuit DC Voltage	Un-05=310.0V DC Voltage	0.1V	Display DC voltage of inverter main circuit.	10V/400V or 10V/800V
Un-06	External Analog Command VIN	Un-06=100% Voltage ~Cmd.	0.1%	—	10V/100%
Un-07	External Analog Command AIN	Un-07=100% Current ~Cmd.	0.1%	—	20mA/100%
Un-08	Multi-Function Analog Input Command AUX	Un-08=100% Multi_Fun ~Cmd.	0.1%	—	10V/100%
Un-09	External Analog Output AO1	Un-09=100% Term.AO1 Output	0.1%	—	10V/100%
Un-10	External Analog Output AO1	Un-10=100% Term.AO2 Output	0.1%	—	10V/100%
Un-11	Input Terminal Status	Un-11= 00000000 I/P Term. Status	—	 <p>0:OPEN 1:CLOSE</p> <p>Input terminal① Input terminal② Input terminal③ Input terminal④ Input terminal⑤ Input terminal⑥ Input terminal⑦ Input terminal⑧</p>	—
Un-12	Output Terminal Status	Un-12= 00000000 O/P Term. Status	—	 <p>0:OPEN 1:CLOSE</p> <p>Relay Contact RA-RC (or R1A-R1C) Photo-Contact DO1-DOG Photo-Contact DO2-DOG(or R2A-R2C) Reserved Reserved Reserved Reserved</p>	—

Note : Term. is terminal abbrev.

Parameter No.	Name	LCD display (English)	Unit	Description	Multi-function Analog Output Level
Un-13	Amount of PG Speed Feedback	Un-13= 100.0% PG Feedback.	0.1%	100.0%=MAX. output frequency	10V/MAX. Output Frequency
Un-14	Amount of PG Speed Compen.	Un-14= 100.0% PG Compen.	0.1%	100.0%=MAX. output freq.	10V/MAX. Output Frequency
Un-15	PID Control Input	Un-15= 100% PID Input	0.1%	100.0%=MAX. output freq.	10V/Max. output frequency
Un-16	PID Control Output 1	Un-16= 100% PID Output1	0.1%	100.0%=MAX. output freq.	10V/Max. output frequency
Un-17	PID Control Output 2	Un-17= 00% PID Output2	0.1%	100.0%=MAX. output freq.	10V/Max. output frequency
Un-18	Fault Message 1	Overcurrent Message1	—	Fault message occurred now	—
Un-19	Fault Message 2	Overcurrent Message2	—	Fault message occurred last time	—
Un-20	Fault Message 3	Overheat Message3	—	Fault message occurred last two time	—
Un-21	Fault Message 4	Overtorque Message4	—	Fault message occurred last three time	—
Un-22	The Parameter Of Time Period Between Last Fault And The Nearest Fault.	Un-22= 2400Hr Last Fault Run Time	1Hr	The value of 'Run Elapse Time' parameter will be cleared after fault has been cleared.	—
Un-23	Frequency Command While Fault Occurred	Un-23= 60.00Hz Last Fault Freq.Cmd.	0.01Hz	—	—
Un-24	Output Freq. While Fault Occurred	Un-24= 60.00Hz Last Fault O/P Freq.	0.01Hz	—	—
Un-25	Output Current While Fault Occurred	Un-25= 12.5A Last Fault O/P I	0.1A	—	—
Un-26	Output Voltage While Fault Occurred	Un-26= 220.0V Last Fault O/P V	0.1V	—	—
Un-27	DC Voltage While Fault Occurred	Un-27= 310.0V Last Fault O/P V	0.1V	—	—
Un-28	I/P Terminal Status While Fault Occurred	Un-28= 00000000 Last Fault I/P Term.	—	Same as Un-11, display terminal status	—
Un-29	O/P Terminal Status While Fault Occurred	Un-29= 00000000 Last Fault O/P Term.	—	Same as Un-12, display terminal status	—
Un-30	Time Elapsed After Power-On	Un-31= 00002Hr P Elapsed Time	1Hr	Display total time elapsed after power ON	—
Un-31	Time Elapsed After Run	Un-31= 00002Hr R Elapsed Time	1Hr	Display total time elapsed after pressing RUN	—
Un-32	EPROM S/W Version	Un-32= 00001 Soft Number	—	-Manufacturing use-	—
Un-33	Feedback Motor Speed	Un-33= 00000rpm Motor Speed	1rpm	Display motor speed while PG feedback is set.	10V/MAX. Motor Speed
Un-34	PID Feedback Display *1	Un-34= 00000 PID Feedback	1*2	Displays PID feedback signal	

\*1. The parameters are available for 74.03 and later software version only.

\*2. The unit can be changed through parameter Cn-28 and Sn-70.

- (1) Frequency Command (Un-01)
- (2) Output Frequency (Un-02)
- (3) Output Current (Un-03)
- (4) Output Voltage (Un-04)
- (5) Main Circuit DC Voltage (Un-05)
  - Through the settings of Sn-33, Sn-34, the above contents can be displayed at the multi-function analog output terminals (AO1, AO2) in different voltage level of (0~10V)
- (6) External Analog Command VIN (Un-06)
  - The parameter can monitor the external analog terminal voltage VIN (0~100%/0~10V). The voltage can be output through the multi-function analog output terminal AO1, AO2 (Sn-33=05 or Sn-34=05). The output voltage is the PID feedback voltage when the PID function is used. Please refer to page 3-7, “PID controller block diagram”.
- (7) External Analog Command AIN (Un-07)
  - The parameter can monitor the external analog terminal current AIN (0~100%/0~20mA). The current can be output through the multi-function analog output terminal AO1, AO2 (Sn-33=06 or Sn-34=06). The output current is the PID feedback voltage when the PID function is used. Please refer to page 3-7, “PID controller block diagram”.
- (8) Multi-Function Analog Input Command AUX (Un-08)
  - The parameter can monitor the multi-function analog input terminal AUX voltage (0~100%/0~20mA). The voltage can be output through the multi-function analog output terminal AO1, AO2 (Sn-33=07 or Sn-34=07). The output voltage is the PID target voltage (reference) when the PID function is used. Please refer to page 3-7, “PID controller block diagram”.
- (9) External Analog Output AO1, AO2 (Un-09, Un-10)
  - The parameter can monitor analog output terminal AO1, AO2 voltage (0~10V). Their output gain can be adjusted through the setting of parameters Bn-14 or Bn-15. Their outputs are determined and varied proportionally according to the setting of (Sn-33 or Sn-34).
- (10) Input Terminal Status (Un-11)
  - The parameter will monitor the status of input terminal ①~⑧: ‘ON’ or ‘OFF’.
- (11) Output Terminal Status (Un-12)
  - The parameter will monitor the status of input terminal RA-RC or R1A-R1C, DO1-DOG, DO2-DOG or R2A-R2C : ‘ON’ or ‘OFF’.

(12) PG Speed Feedback and PG Speed Compensation (Un-13, Un-14)

- These parameters will monitor the PG speed feedback and PG speed compensation signal if PG feedback function is used.

(13) PID Control Input (Un-15)

(14) PID Control Output1 (Un-16)

(15) PID Control Output2 (Un-17)

- The values in Fig. 12 (on page 3-7) can be monitored through the parameters of Un-15, Un-16 and Un-17. Moreover, the multi-function analog output terminal AO1, AO2 can be used to monitor the output value through the proper setting of Sn-33 and Sn-34.

(16) Message 1 (Un-18)

(17) Message 2 (Un-19)

(18) Message 3 (Un-20)

(19) Message 4 (Un-21)

- These parameters are used to display the fault messages whenever the fault occurred. The user can take proper action for trouble-shooting based upon the displayed message.

(20) The Cumulative Operation Time Setting (Un-22)

- The parameter is used to count the elapsed time from the previous fault to the latest fault occurred recently. Its setting range is 0~65536 Hr. After the fault have been cleared and system reset again, the Un-22 will be cleared to zero and counted again.

(21) The Frequency Command While Last Fault Occurred (Un-23)

(22) The Output Frequency While Last Fault Occurred (Un-24)

(23) The Output Current While Last Fault Occurred (Un-25)

(24) The Output Voltage While Last Fault Occurred (Un-26)

(25) The DC Voltage While Last Fault Occurred (Un-27)

(26) The Input Terminal Status While Last Fault Occurred (Un-28)

(27) The Output Terminal Status While Last Fault Occurred (Un-29)

- The above parameters will display the inverter status when the fault occurred lately. The contents of parameters Un-23~29 will be cleared after the faults have been cleared and the system reset again.

(28) The Cumulative Time Whenever The Input Power Is On (Un-30)

- The parameter will record the cumulative operation time from power-on to power-off. Its value is 0~65535 Hr. If the value exceed 65535, it will restart from 0 again.

- (29) The Cumulative Run Time Whenever The Output Power Is On (Un-31)
- The parameter will record the cumulative operation time from power-on to power-off. Its value is 0~65535 Hr. If the value exceeds 65535, it will restart from 0 again.
- (30) The EPROM Software Version (Un-32)
- The parameter will specify the updated software version in this inverter.
- (31) Motor Speed While PG Feedback Is Set. (Un-33)
- While PG feedback control is set, the motor speed can be monitored through Un-33.
- (32) PID Feedback Display (Un-34)
- While PID Function is enabled, the PID feedback signal can be monitored through Un-34. While PID Function is not enabled, the Un-34 will be zero.
  - The display content can be set by Cn-28, Sn-70, Bn-45 and Bn-46.  
Cn-28 sets the decimal point position of Un-34.  
Sn-70 sets the unit of Un-34.  
Bn-45 is the equivalent value displayed for 0% PID Feedback.  
Bn-46 is the equivalent value displayed for 100% PID Feedback.
  - Before monitoring PID feedback signal, be sure to set the value of Cn-28, Sn-70, Bn-45 and Bn-46.

## 4. Fault display and troubleshooting

### 4.1 General

The MA7200 have the protective and warning self-diagnostic functions. If fault occurs, the fault code is displayed on the digital operator. The fault contact output (RA-RB-RC or R1A-R1B-R1C, DO1, DO2 or R2A-R2C) operates, and the inverter shut off to stop the motor. If warning occurs, the digital operator will display the warning code. However, the fault-contact output does not operate. (Except some certain cases, see page on ‘Warning and Self-Diagnosis Functions’). The digital operator will return to its previous status when the above warning is clear.

- When a fault has occurred, refer to the following table to identify and to clear the cause of the fault.
- Use one of the following methods to reset the fault after restarting the inverter.

1. Stop the inverter.
2. Switch the fault reset input at terminal ④ signal or press the RESET key on the digital operator.
3. Turn off the main circuit power supply and turn on again.

## 4.2 Error Message and Troubleshooting

### (A) Protective Function

LCD Display (English)	Fault Contents	Fault Contact Output
Fault DC Volt. Low	The main circuit DC voltage becomes lower than the low voltage detection level (Cn-39).	Operation
Fault Over Current	The inverter output current becomes approx. 200% and above the inverter rated current.	Operation
Fault Ground Fault	A ground fault occurs at the inverter output side and the ground-fault current exceeds approx. 50% of the inverter rated current.	Operation
Fault Over Voltage	The main circuit DC voltage becomes excessive because of regeneration energy caused by motor decelerating.	Operation
Fault Over Heat	The temperature of the cooling fin reaches the detection level.	Operation
Fault Motor Over Load	Motor overload is detected by the electronic thermal relay. (motor protection)	Operation
Fault Inverter Over Load	The electronic thermal sensor detects inverter overload while the output current exceeds 112% of rated value. (inverter protection)	Operation
Fault Over Torque	Over torque is detected while the output current is larger than or equal to the setting of Cn-26. (machine protection)	Operation
Fault Ext. Fault3	External fault signal ③	Operation
Fault Ext. Fault5	External fault signal ⑤	
Fault Ext. Fault6	External fault signal ⑥	
Fault Ext. Fault7	External fault signal ⑦	
Fault Ext. Fault8	External fault signal ⑧	
Fault Inverter EEPROM	EEPROM fault	Operation
	EEPROM (BCC, no.) is bad.	
	A/D converter (inside the CPU) fault	
Fault PG Over Sp.	Excessive PG speed fault	Operation
Fault PG Open	PG is open-circuit	Operation
Fault Sp.Deviat Over	Excessive speed deviation	Operation
Fault RS-485 Interrupt	MODBUS Communication fault occurs .The inverter remains operating.	operation

Error Causes	Action to Be Taken
<ul style="list-style-type: none"> <li>• Power capacity is too small.</li> <li>• Voltage drop due to wiring resistance.</li> <li>• A motor of large capacity connected to the same power system has been started.</li> <li>• Defective electromagnetic contractor.</li> </ul>	<ul style="list-style-type: none"> <li>• Check the source voltage and wiring.</li> <li>• Check the power capacity and power system.</li> </ul>
<ul style="list-style-type: none"> <li>• Extremely rapid accel.</li> <li>• Short-circuit or ground- fault at the inverter output side.</li> <li>• Motor of a capacity greater than the inverter rating has been started.</li> <li>• High-speed motor and pulse motor has been started.</li> </ul>	<ul style="list-style-type: none"> <li>• Extend the accel. time.</li> <li>• Check the load wiring.</li> </ul>
<ul style="list-style-type: none"> <li>• Motor dielectric strength is insufficient.</li> <li>• Load wiring is not proper.</li> </ul>	<ul style="list-style-type: none"> <li>• Check the motor wiring impedance and the load wiring.</li> </ul>
<ul style="list-style-type: none"> <li>• Insufficient deceleration time.</li> <li>• High input voltage compared to motor rated voltage.</li> </ul>	<ul style="list-style-type: none"> <li>• Extend the accel. time.</li> <li>• Use a braking resistor.</li> </ul>
<ul style="list-style-type: none"> <li>• Defective cooling fan.</li> <li>• Ambient temperature rise</li> <li>• Clogged filter.</li> </ul>	<ul style="list-style-type: none"> <li>• Check for the fan, filter and the ambient temperature.</li> </ul>
<ul style="list-style-type: none"> <li>• Overload, low speed operation or extended accel. time.</li> <li>• Improper V-f characteristic setting</li> </ul>	<ul style="list-style-type: none"> <li>• Measure the temperature rise of the motor.</li> <li>• Decrease the output load.</li> <li>• Set proper V/f characteristic.</li> </ul>
<ul style="list-style-type: none"> <li>• Improper rated current (Cn-09) setting</li> </ul>	<ul style="list-style-type: none"> <li>• Set proper V/f characteristic.</li> <li>• Set proper rated current (Cn-09)</li> <li>• If inverter is reset repetitively before fault removed, the inverter may be damaged.</li> </ul>
<ul style="list-style-type: none"> <li>• Machine errors or overload</li> </ul>	<ul style="list-style-type: none"> <li>• Check the use of the machine.</li> <li>• Set a higher protection level (Cn-32).</li> </ul>
<ul style="list-style-type: none"> <li>• Fault input of external signal ③, ⑤, ⑥, ⑦ and ⑧.</li> </ul>	<ul style="list-style-type: none"> <li>• Identify the fault signal using Un-11.</li> </ul>
<ul style="list-style-type: none"> <li>• Disturbance of external noise</li> <li>• Excessive impact or vibration</li> </ul>	<ul style="list-style-type: none"> <li>• Reset NVRAM by running Sn-03.</li> <li>• Replace the control board if the fault can't be cleared.</li> </ul>
<ul style="list-style-type: none"> <li>• Improper setting of ASR parameter or over-speed protection level.</li> </ul>	<ul style="list-style-type: none"> <li>• Check the parameters of ASR and the protection level.</li> </ul>
<ul style="list-style-type: none"> <li>• The PG wiring is not properly connected or open-circuit.</li> </ul>	<ul style="list-style-type: none"> <li>• Check the PG wiring.</li> </ul>
<ul style="list-style-type: none"> <li>• Improper setting of ASR parameter or speed deviation level.</li> </ul>	<ul style="list-style-type: none"> <li>• Check parameters of ASR and speed deviation level.</li> </ul>
<ul style="list-style-type: none"> <li>• External noise</li> <li>• Excessive vibration or impact</li> <li>• Communication wire not properly contacted</li> </ul>	<ul style="list-style-type: none"> <li>• Check the parameter setting, including Sn-01, Sn-02.</li> <li>• Check if the comm. wire is not properly contacted.</li> <li>• Restart, if fault remains, please contact to us.</li> </ul>

## (B). Warning and Self-Diagnosis Functions

LCD Display (English)	Fault Contents	Fault Contact Output
(blinking) Alarm DC Volt. Low	The main circuit DC voltage becomes lower than the lower under-voltage level before the motor starts.	No operation
(blinking) Alarm Over Voltage	The main circuit DC voltage becomes higher than the lower under-voltage level before the motor starts.	No operation
(blinking) Alarm Over Heat	The thermal protection contact is input to the external terminal.	No operation
(blinking) Alarm Over Torque	Over torque is detected while the output current is larger than or equal to the setting of Cn-26. However, the Sn-12 has been set such that the inverter continue to run and disregard the over-torque warning.	No operation
—	Stall prevention operates while acceleration.	No operation
	Stall prevention operates while running	
	Stall prevention operates while deceleration.	
(blinking) Alarm External Fault	Forward and reverse rotation commands are simultaneously detected for a period of time exceeding 500ms. (The inverter is stopped according to the stop method preset by Sn-04.)	No operation
(blinking) Alarm RS-485 Interrupt	MODBUS Communication fault occurs. The inverter remains operating.	No operation
Comm. Fault	Transmission fault of digital operator	No operation
(blinking) Alarm B.B.	External B.B. signal (terminal ③) is input (The inverter stops and the motors stops without braking)	No operation
Alarm Input Error	Improper inverter capacity (Sn-01) setting.	No operation
	Improper setting of multi-function input signal (Sn-25, 26, 27 and 28).	No operation
	Improper setting of V/F characteristic (Cn-02~08)	No operation
	Improper setting of Cn-18, Cn-19	No operation
(blinking) Alarm Over Speed	Excessive speed (operation remains)	No operation
(blinking) Alarm PG Open	PG Open-circuit (operation remains)	No operation
Alarm Sp.Deviat Over	Excessive speed deviation (operation remains)	No operation
Load Fail	Error during upload and download (operation remains)	No operation
EEPROM Fault	Operator EEPROM error.	No operation
Upload Error	Data incorrect during Communication from the operator to the inverter.	No operation
Download Error	Data incorrect during Communication from the inverter to the operator.	No operation
Alarm Auto Tun-Error	Motor parameter autotuning error	No operation

Error Causes	Action to Be Taken
<ul style="list-style-type: none"> <li>Input voltage drop</li> </ul>	<ul style="list-style-type: none"> <li>Measure the main circuit DC voltage, if the voltage is lower allowance level, regulate the input voltage.</li> </ul>
<ul style="list-style-type: none"> <li>Input voltage rise</li> </ul>	<ul style="list-style-type: none"> <li>Measure the main circuit DC voltage, if the voltage is higher than allowance level, regulate the input voltage.</li> </ul>
<ul style="list-style-type: none"> <li>Overload</li> <li>Cooling fan fault. Ambient temperature rises.</li> <li>Clogged filter.</li> </ul>	<ul style="list-style-type: none"> <li>Check for the fan, filter and the ambient temperature.</li> </ul>
<ul style="list-style-type: none"> <li>Machine error or overload</li> </ul>	<ul style="list-style-type: none"> <li>Check the use of the machine.</li> <li>Set a higher protection level (Cn-32).</li> </ul>
<ul style="list-style-type: none"> <li>Insufficient Accel./Decel. Time</li> <li>Overload</li> <li>Excessive load impact occurs while operating</li> </ul>	<ul style="list-style-type: none"> <li>Increase Accel./Decel. Time.</li> <li>Check the load.</li> </ul>
<ul style="list-style-type: none"> <li>Operation sequence error</li> <li>3-wire/2-wire selection error</li> </ul>	<ul style="list-style-type: none"> <li>Check the circuit of system</li> <li>Check the setting of system parameters Sn-25, 26, 27, and 28.</li> </ul>
<ul style="list-style-type: none"> <li>External noise</li> <li>Excessive vibration or impact on Communication wire</li> <li>Not properly contacted</li> </ul>	<ul style="list-style-type: none"> <li>Check the parameter setting, including Sn-01, Sn-02.</li> <li>Check if the comm. wire is not properly contacted.</li> <li>Restart, if fault remains, please contact to us.</li> </ul>
<ul style="list-style-type: none"> <li>Comm. between digital operator and inverter has not been established after system starts for 5 seconds.</li> <li>Communication is established after system starts, but transmission fault occurs for 2 seconds.</li> </ul>	<ul style="list-style-type: none"> <li>Re-plug the connector of the digital operators.</li> <li>Replace the control board.</li> </ul>
<ul style="list-style-type: none"> <li>External B.B. signal is input.</li> </ul>	<ul style="list-style-type: none"> <li>After external BB signal is removed, execute the speed search of the inverter.</li> </ul>
<ul style="list-style-type: none"> <li>Inverter KVA setting error.</li> </ul>	<ul style="list-style-type: none"> <li>Set proper KVA value. Be aware of the difference of 230V and 460V</li> </ul>
<ul style="list-style-type: none"> <li>The value of Sn-25~Sn-28 is not in ascending order (Ex. Sn-25= 05, Sn-28= 02, those are improper setting).</li> <li>Set speed search command of 21 and 22 simultaneously.</li> </ul>	<ul style="list-style-type: none"> <li>Set these values by order (the value of Sn-25 must be smaller than those of Sn-26, 27, 28)</li> <li>Command 21 and 22 can not be set on two multi-function-input contacts simultaneously.</li> </ul>
<ul style="list-style-type: none"> <li>The values of Cn-02~Cn-08 do not satisfy <math>F_{max} \geq F_A \geq F_B \geq F_{min}</math>.</li> </ul>	<ul style="list-style-type: none"> <li>Change the settings.</li> </ul>
<ul style="list-style-type: none"> <li>Upper limit and lower limit setting is incorrect.</li> </ul>	<ul style="list-style-type: none"> <li>Change the settings.</li> </ul>
<ul style="list-style-type: none"> <li>Improper ASR parameter setting or over-torque protection level.</li> </ul>	<ul style="list-style-type: none"> <li>Check the ASR parameter and over-torque protection level.</li> </ul>
<ul style="list-style-type: none"> <li>The circuit of PG is not properly connected or open-circuit.</li> </ul>	<ul style="list-style-type: none"> <li>Check the wiring of PG.</li> </ul>
<ul style="list-style-type: none"> <li>Improper ASR parameter setting or over-torque protection level.</li> </ul>	<ul style="list-style-type: none"> <li>Check the ASR parameter and over-torque protection level.</li> </ul>
<ul style="list-style-type: none"> <li>Bad communication during operator and inverter.</li> <li>The connector is not properly connected.</li> </ul>	<ul style="list-style-type: none"> <li>Check if the connector is not properly connected.</li> </ul>
<ul style="list-style-type: none"> <li>Operator EEPROM error.</li> </ul>	<ul style="list-style-type: none"> <li>Disable load function of operator.</li> <li>Replace the operator.</li> </ul>
<ul style="list-style-type: none"> <li>Incorrect inverter data format</li> <li>Communication noise.</li> </ul>	<ul style="list-style-type: none"> <li>Download the data to the operator again.</li> <li>Check if the connector is not properly connected.</li> </ul>
<ul style="list-style-type: none"> <li>Communication noise</li> </ul>	<ul style="list-style-type: none"> <li>Check if the connector is not properly connected.</li> </ul>
<ul style="list-style-type: none"> <li>Inverter capacity and motor rating are not properly matched.</li> <li>The wiring between inverter and motor is disconnected.</li> <li>Motor load unbalance.</li> </ul>	<ul style="list-style-type: none"> <li>Correct the inverter/motor capacity ratio, wiring cable and motor load.</li> </ul>

# APPENDIX

## A. Adjusting PID Controller

Use the following procedure to activate PID control and then adjust it while monitoring the response.

1. Enable PID control. (Sn-64 = 1)
2. Increase the Proportional gain Bn-17 as far as possible without creating oscillation.
3. Decrease the Integral Time Bn-18 as far as possible without creating oscillation.
4. Increase the Derivative Time Bn-19 as far as possible without creating oscillation.

The Proportional, Integral and Derivative control function provides closed-loop control, or regulation, of a system process variable (pressure, temperature, etc.). This regulation is accomplished by comparing a feedback signal with a reference signal, which results in an error signal. The PID control algorithm then performs calculations, based upon the PID parameter settings (Bn-16 through Bn-20 on Page 3-2), on this error signal. The result of the PID algorithm is then used as the new frequency reference, or is added to the existing speed reference.

The PID target value can come from the frequency command (from operator) or a Multi-Function Analog Input.

Select the PID Control Feedback signal from external terminal AIN for a current signal (4-20mA DC) or from VIN for a voltage (0-10 VDC).

The Proportional Gain is the value by which the error signal is multiplied to generate a new PID controller output. A higher setting will result in a system with quicker response. A lower setting will result in a more stable yet slower system.

The Integral Time is a parameter that determines how fast the PID controller will seek to eliminate any steady-state error. The smaller the setting, the faster the error will be eliminated. To eliminate the integral function entirely, set this parameter to 0.0 seconds. A lower setting will result in a more responsive system. A higher setting will result in a more stable yet slower system.

The Integral Upper Limit parameter will limit the effect that the integrator can have. It works if the PID controller output is positive or negative. It can also be used to prevent integrator “wind-up.”

The Derivative Time is a parameter that can be adjusted to increase system response to fast load or reference changes, and to reduce overshoot upon startup. To eliminate the differential function entirely, set this parameter to 0.00 seconds.

The PID Output Limit (Cn-51, Cn-52) parameter can be used to set the maximum effect the PID controller will have on the system. It will also limit the PID output when it is either positive or negative.

**NOTE :** When the PID output limit is reached, the integrator will hold and not change in value until the PID output is less than the PID output limit.

The PID Bias (Bn-20) parameter will add a fixed percentage to the PID output. It can be used to tune out small system offsets.

**NOTE :** This parameter is set as a percentage of maximum output frequency.

The above parameters are factory set for optimum results for most applications, and generally do not need to be changed.

The PID Primary Delay Time parameter adds a filter to the PID output to keep it from changing too quickly. The higher the setting, the slower the PID output will change.

All of these parameters are interactive, and will need to be adjusted until the control loop is properly tuned, i.e. stable with minimal steady-state error. A general procedure for tuning these parameters is as follows:

1. Adjust Proportional Gain until continuous oscillations in the Controlled Variable are at a minimum.
2. The addition of Integral Time will cause the steady-state error to approach zero. The time should be adjusted so that this minimal error is attained as fast as possible, without making the system oscillate.
3. If necessary, adjust Derivative Time to reduce overshoot during startup. The inverter's acceleration and deceleration rate times can also be used for this purpose.

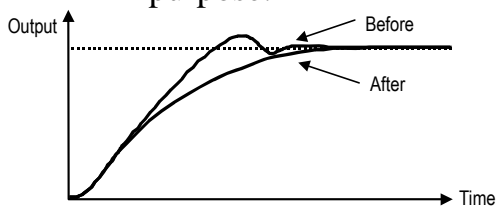

If overshoot occurs, shorten the derivative time (D) and lengthen the integral time (I).

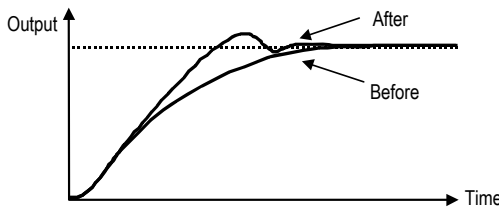

To rapidly stabilize the control conditions even when overshooting occurs, shorten the integral time (I) and lengthen the derivative time (D).

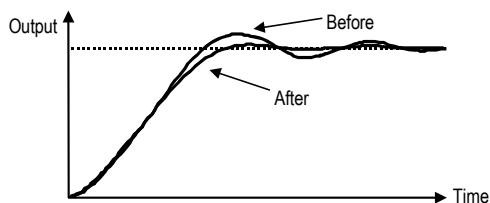

If oscillation occurs with a longer cycle than the integral time (I) setting, then the integral operation is strong. The oscillation will be reduced as the integral time (I) is lengthened.

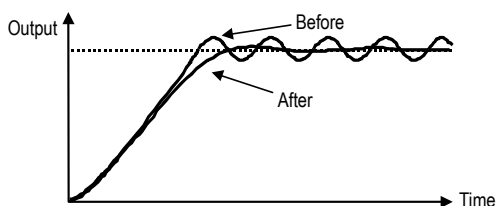

If oscillation cycle is short and approx. the same as the derivative time (D) setting, then the derivative operation is strong. The oscillation will be reduced as the derivative time (D) is shortened. If even setting the derivative time (D) to 0.00 cannot reduce oscillation, then either decrease the proportional gain (P) or raise the PID primary delay time constant.

## B. Supplementary on PID Control Block Diagram

A PID Control Block Diagram is:

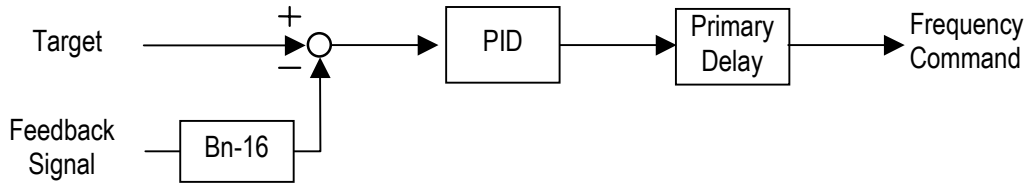

Fig. 47. PID Control Block Diagram

Note :

1. A target signal may come from the LCD Digital Operator, RS-485 Port or Multi-Function Analog Input Terminal-AUX Setting. (upon Sn-05 setting).
2. The detected signal can be input either from terminal VIN (Sn-24=0, Voltage Command 0~10V) or from terminal AIN (Sn-24=1, Current Command 4~20mA).
3. If the target signal is from the terminal AUX, please use the wiring diagram indicated below: (Sn-05=01, Sn-29=09).

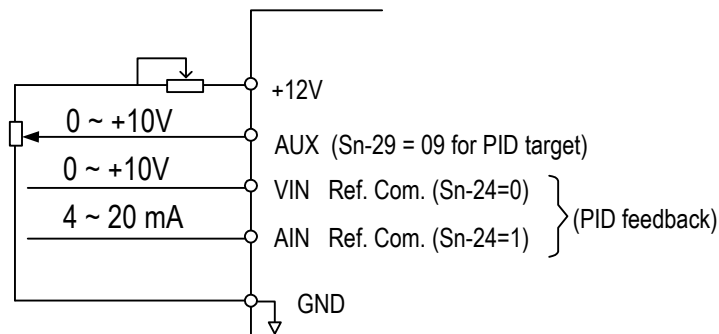

Fig. 48. PID Wiring Diagram

4. Refer to Pages 3-7 to 3-9 for more details about PID use.

### C. Wiring for PG Feedback Use

The MA7200 inverter has a built-in PG interface, no external PG feedback option card is needed. An independent DC source of +12V should be provided from an external source.

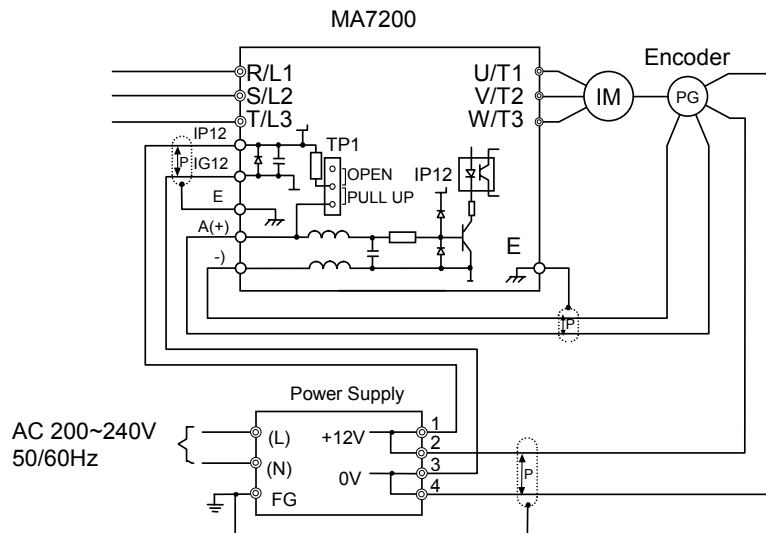
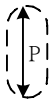

Fig. 49. Wiring of PG feedback

Note :



1. : Isolated twisted cable wire.
2. Notation for PG terminals

Terminal	Function
A(+)	PG signal input terminal. The voltage level is (H: 4~12V, L: ≤1V).
A(-)	Its Max. frequency is < 32767 Hz
IP12	Terminals feed in the (+12)VDC external power source (+12V± 10%, the Max. current is 40mA)
IG12	
+12V	(+12)V DC source (+12V± 10%, min. 0.5A)
0V	
E	Inverter ground.

3. Please refer to page 3-27 and 3-69 for more details on PG feedback.
4. The A(+), A(-), IP12, IG12 terminals are integrated as CN2 in compact version. (see page 1-9~1-10). The code No. of the wire is 4H339D0250001.
5. The PG interface only allows the open-collector interface drive or complementary interface drive.
6. The short pin of TP1 set to PULL UP position for open-collector interface (factory setting) and set to OPEN position for complementary interface. The PG interface only allows the open-collector interface drive or complementary interface drive.
7. The shielded twisted-pair cable wire should be used between the inverter and PG, its length should be less than 150 feet.

## D. RS-485 Communication Interface

- MA7200 RS-485 interface (terminal S(+), S(-)) can provide MODBUS protocol for communication. PROFIBUS protocol for communication is possible with an optional PROFIBUS Communication Card (MA-SP).
- Wiring diagram of MODBUS and PROFIBUS-DP:

### (a) MODBUS Protocol Communication

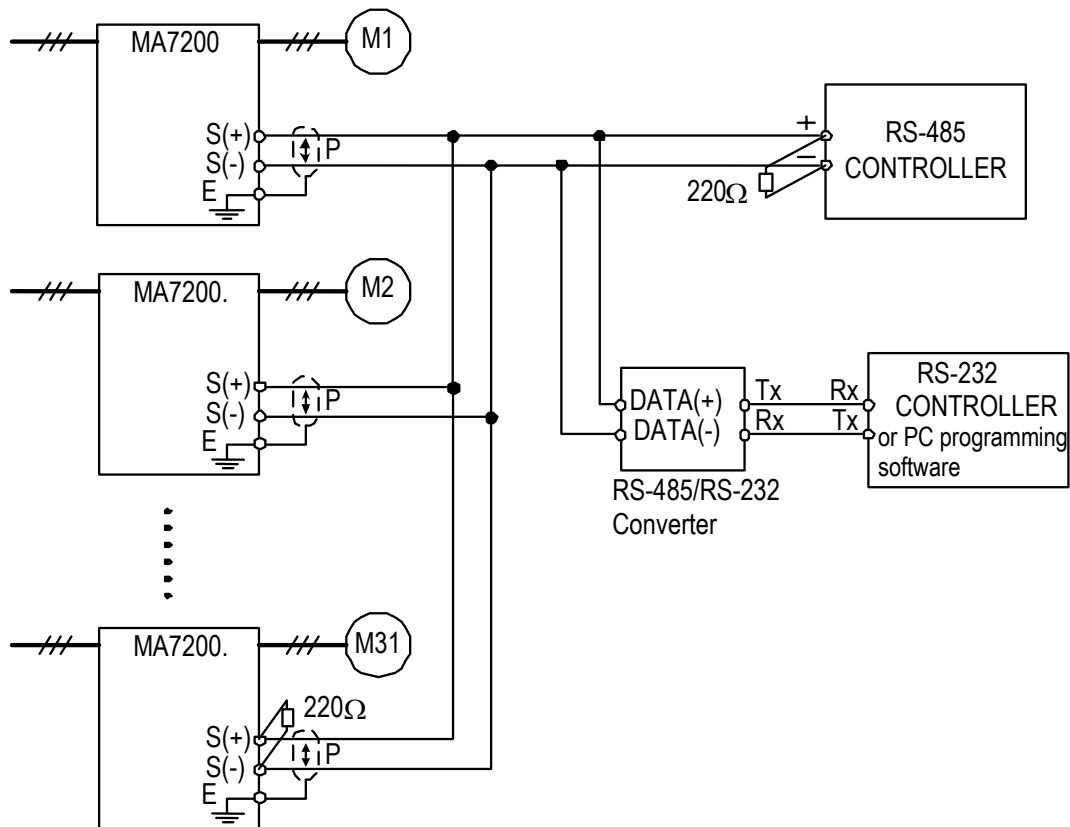

Fig. 50. Wiring for MODBUS Protocol Communication

- Note :1. A Host Controller with RS-485 interface can communicate with the MA7200 unit through RS-485 interface connection directly. If the Host Controller does not provide the RS-485 port and its RS-232 port is available (such as PC programming), an RS-485/RS-232 conversion card should be used to connect between this Host Controller and the MA7200 unit.
2. A MODBUS Host Controller can drive the network with no more than 31 inverters connected, using MODBUS communication standard. If the inverter (e.g., MA7200) is at the end of the network, it must have terminating resistors 220Ω at both terminals. All other inverters in the system should not have terminators.
  3. Please refer to “MA7200 RS-485 MODBUS Communication Application Manual”.

## (b) PROFIBUS Protocol Communication

The optional MA-SP PROFIBUS Communication Card supports the PROFIBUS protocol. The optional MA-SP PROFIBUS Communication Card can be placed at the control board. An independent 24V DC Power Supply is needed for all MA-SP option cards.

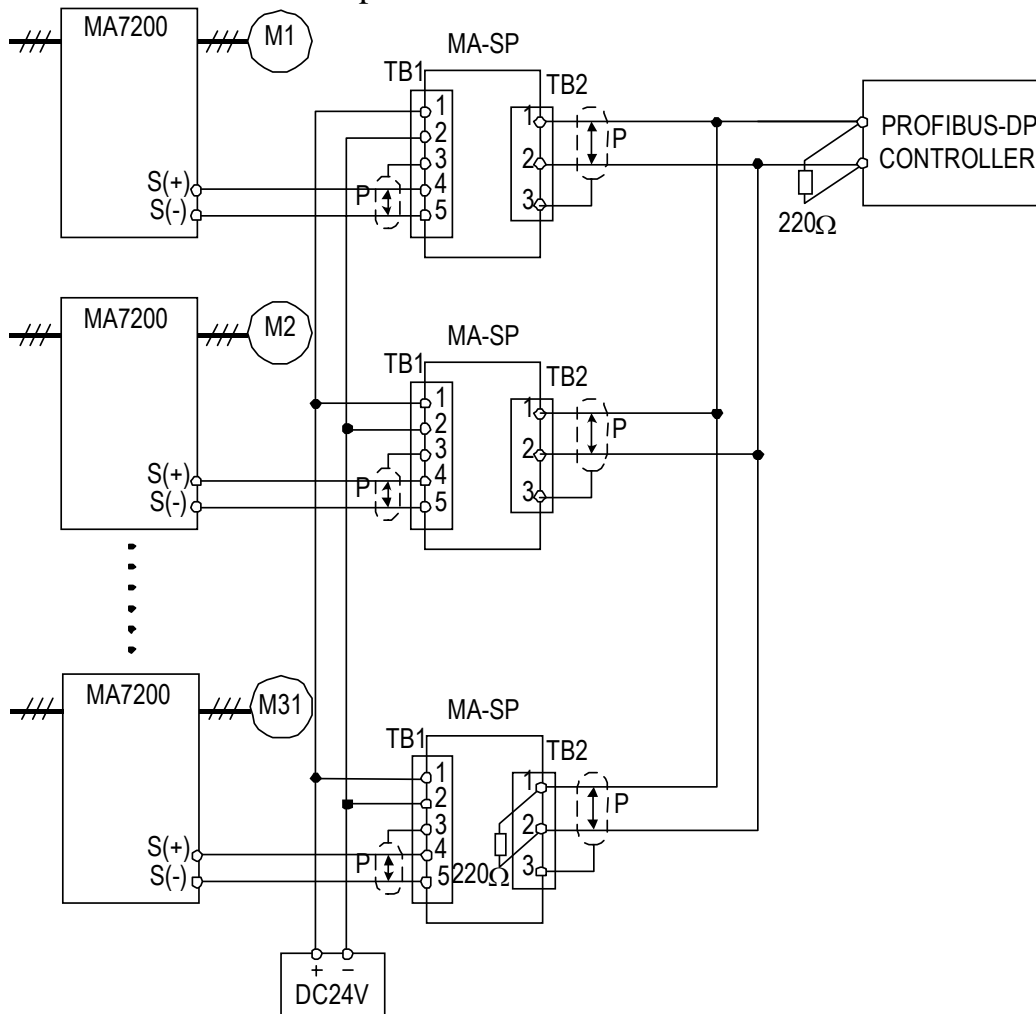

Fig. 51. Wiring for PROFIBUS Protocol Communication

- Note :
1. Code No. : 4H300D0290009
  2. The optional MA-SP card will consume about  $2.4W(=24.0V*0.1A)$ . Select the proper DC power supply to meet your system capacity based upon the station number.
  3. A maximum of 31 PROFIBUS-DP stations (nodes) may be contained within a single network segment. If the drive is at the end of the network, it must have  $220\Omega$  between terminals (S-, S+).
  4. For more details, refer to the “MA7200 PROFIBUS-DP Communication Application Manual”.

## E. SINK/SOURCE Typical Connection Diagram

- The UL/CUL Standard Type Control Board (Code No. : 4P101C0060002) Terminal ①~⑧ can be set as Sink or Source Type Input Interface. Typical connection examples are shown below.

(a) SINK Type Input Interface: The short pin of TP2 is set to SINK position.

- Transistor (Open-collector) used for operation signal.

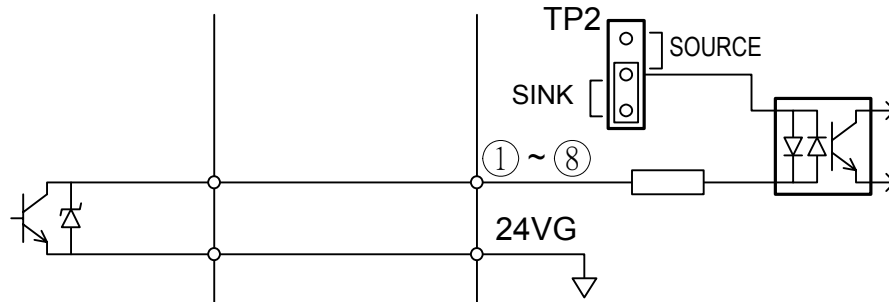

- NPN Sensor (Sink) used for operation signal.

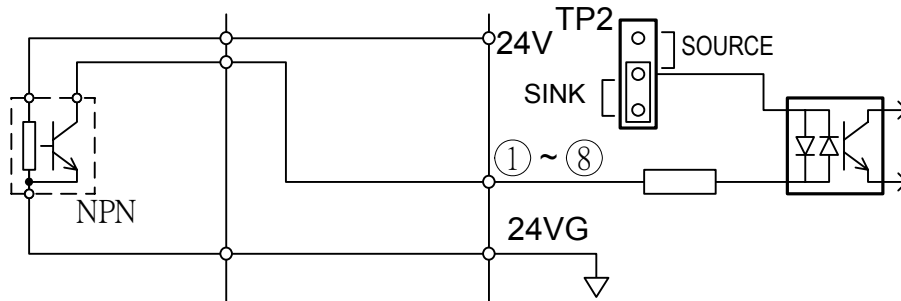

(b) SOURCE Type Input Interface : The short pin of TP2 is set to SINK position.

- Transistor (Open-collector) used for operation signal.

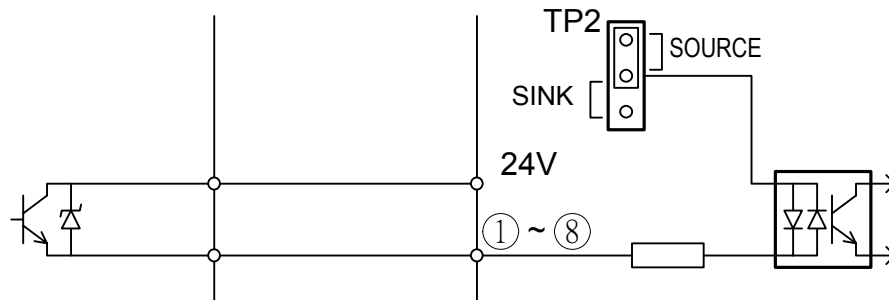

- PNP Sensor (Source) used for operation signal.

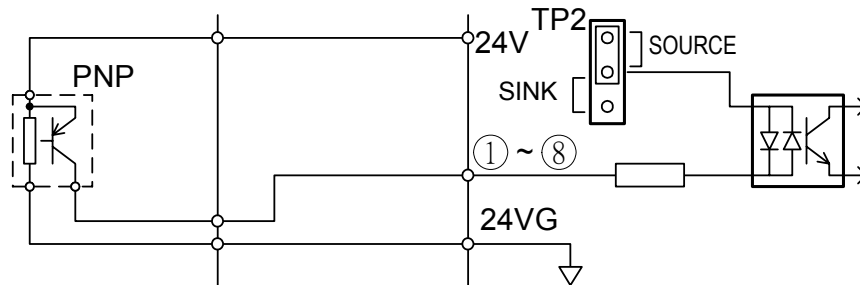





## F. Sensorless Vector Control Set-up

The MA7200 has two standard two selectable control modes, V/F Control Mode (Sn-67=0) and Sensorless Vector Control Mode (Sn-67=1). When the Sensorless Vector Control Mode is selected, be sure that the inverter capacity and the motor rating are suitably matched.

The AUTOTUNE feature can be used to identify and store the important motor parameters for the Sensorless Vector Control Mode.

Refer to pages 3-28, 3-29 and 3-73 for more details about Sensorless Vector Control.

- The Sequence of Motor Parameter Autotuning:

1. Disconnect the motor load and make sure that the wiring between the inverter and the motor is suitable. The difference between inverter capacity and motor rating should not be greater than two frame sizes.
2. Switch to PRGM operation mode by pressing the Digital Operator  key.
3. Input the Motor Rated Voltage Data to parameter Cn-03 (Max. Output Voltage) and the Motor Rated Frequency to parameter Cn-04 (Max. Voltage Frequency) using data from motor's nameplate. Enable Sensorless Vector Control Mode (Sn-67= 1).
4. Enable the Autotuning Function by setting Sn-66= 1.
5. Switch to DRIVE operation mode by pressing the  key, then run the inverter by pressing the  key.
6. The inverter system immediately enters into the autotuning operation until completing the autotuning procedure (normally about 25 seconds). The inverter then returns to a stopped condition. Press the  key to stop the parameter autotuning operation if an abnormality occurs during autotuning operation.
7. Finally, press the  key to return the system to normal operation mode. The value of motor parameter will be automatically stored in these parameters: Cn-57 (Motor Line-to-Line Resistance R1), Cn-58 (Motor Rotor Equivalent Resistance R2), Cn-59 (Motor Leakage Inductance Ls) and Cn-60 (Mutual Inductance Lm).

- The Operations and Adjustments of Sensorless Vector Control :
  1. Make sure the inverter capacity and motor rating is suitably matched. Use the AUTOTUNE feature to identify and store the motor parameters in the first time sensorless vector operation after installation, and key in the Motor Rated Voltage data into Cn-03 and the Motor Rated Frequency into Cn-04 according to the motor nameplate.
  2. Enable the Sensorless Vector Control Mode by setting Sn-67= 1.
  3. Increase setting Cn-57 to increase the generating torque at low speed. Decrease setting Cn-57 to reduce the generating torque to avoid overcurrent trip at low speed.
  4. Adjust setting Cn-61 if the speed accuracy needs to improve. When the actual speed is low, increase the set value and when the actual speed is high, decrease the set value.
  5. If the motor speed is not stable or the load inertia is too large, increase the Cn-40 (Slip Compensation Primary Delay Time) setting.  
If the speed response is slow, decrease the setting of Cn-40.

## G. Notes for Circuit Protection and Environmental Ratings

### ■ Circuit Protection

The MA7200 is “suitable for use in a circuit capable of delivering not more than \_\_\_rms symmetrical amperes\_\_\_ V maximum.” Where the rms value symmetrical amperes and V maximum are to be as follows:

Device Rating		Short Circuit Rating (A)	Maximum Voltage (V)
Voltage	HP		
230V	1.5 ~ 50	5,000	240V
	51 ~ 100	10,000	
460V	1.5 ~ 50	5,000	480V
	51 ~ 200	10,000	

### ■ Environmental Ratings

The MA7200 is intended for use in pollution degree 2 environments.















### ■ Field Wiring Terminals and Tightening Torque

The wiring terminals and tightening torque are listed as follows. (Main Circuit Terminal Specifications – use 140/167°F(60/75°C) copper wire only).

(A) 230V Class (NEMA1)

Circuit	Inverter Rating (HP)	Terminals Mark	Cable Size (AWG)	Terminals	Tightening Torque (Pound-inch)
Main Circuit	1	L1, L2, L3, T1, T2, T3, B1/P, B2, ⊖	14 ~ 10	M4	10
		⊕	14 ~ 10	M4	10
	2	L1, L2, L3, T1, T2, T3, B1/P, B2, ⊖	14 ~ 10	M4	10
		⊕	12 ~ 10	M4	10
	3	L1, L2, L3, T1, T2, T3, B1/P, B1/R, B2, ⊖	12 ~ 10	M4	10
		⊕	12 ~ 10	M4	10
	5	L1, L2, L3, T1, T2, T3, B1/P, B1/R, B2, ⊖	12 ~ 10	M4	10
		⊕	10	M4	10
	7.5	L1, L2, L3, T1, T2, T3, B1/P, B1/R, B2, ⊖	8	M4	10
		⊕	10 ~ 8	M4	10
	10	L1, L2, L3, T1, T2, T3, B1/P, B1/R, B2, ⊖	8	M4	10
		⊕	10 ~ 8	M4	10
	15	L1, L2, L3, T1, T2, T3, B1/P, B2, ⊖	8 ~ 6	M6	30
		⊕	10 ~ 8	M6	35
	20	L1, L2, L3, T1, T2, T3, B1/P, B2, ⊖	8 ~ 6	M6	30
		⊕	10 ~ 8	M6	35
25	L1, L2, L3, T1, T2, T3, ⊕, ⊖	4	M6	35	
	⊕	6	M6	35	
30	L1, L2, L3, T1, T2, T3, ⊕, ⊖	2	M8	78	
	⊕	6	M10	156	
40	L1, L2, L3, T1, T2, T3, ⊕, ⊖	2/0	M8	78	
	⊕	4	M10	156	
Control Circuit	All series	①~⑧, 15V, VIN, AIN, AUX, AO1, AO2 RA, RB, RC, DO1, DO2, (or R2A, R2C)	24~14	M2.6	4

(B) 460V Class (NEMA1)

Circuit	Inverter Rating (HP)	Terminals Mark	Cable Size (AWG)	Terminals	Tightening Torque (Pound-inch)
Main Circuit	1	L1, L2, L3, T1, T2, T3	14 ~ 10	M4	10
			14 ~ 10	M4	10
	2	L1, L2, L3, T1, T2, T3	14 ~ 10	M4	10
			14 ~ 10	M4	10
	3	L1, L2, L3, T1, T2, T3, B1/P, B2, ⊖	14 ~ 10	M4	10
			14 ~ 10	M4	10
	5	L1, L2, L3, T1, T2, T3, B1/P, B2, ⊖	14 ~ 10	M4	10
			12 ~ 10	M4	10
	7.5	L1, L2, L3, T1, T2, T3, B1/P, B1/R, B2, ⊖	12 ~ 10	M4	10
			12 ~ 10	M4	10
	10	L1, L2, L3, T1, T2, T3, B1/P, B1/R, B2, ⊖	10	M4	10
			10	M4	10
	15	L1, L2, L3, T1, T2, T3, B1/P, B2, ⊖	10 ~ 8	M6	15
			12 ~ 10	M6	35
	20	L1, L2, L3, T1, T2, T3, B1/P, B2, ⊖	10 ~ 8	M6	15
			12 ~ 10	M6	35
	25	L1, L2, L3, T1, T2, T3, ⊕, ⊖	8	M6	35
			8	M6	35
	30	L1, L2, L3, T1, T2, T3, ⊕, ⊖	6	M6	35
			8	M6	35
40	L1, L2, L3, T1, T2, T3, ⊕, ⊖	4	M8	78	
		8	M10	156	
50	L1, L2, L3, T1, T2, T3, ⊕, ⊖	4	M8	78	
		6	M10	156	
60	L1, L2, L3, T1, T2, T3, ⊕, ⊖	2	M8	78	
		6	M10	156	
75	L1, L2, L3, T1, T2, T3, ⊕, ⊖	2/0	M8	78	
		4	M10	156	
Control Circuit	All series	①~⑧, 15V, VIN, AIN, AUX, AO1, AO2 RA, RB, RC, DO1, DO2, (or R2A, R2C)	24~14	M2.6	4

(C) 230V Class (NEMA4)

Circuit	Inverter Rating (HP)	Terminals Mark	Cable Size (AWG)	Terminals	Tightening Torque (Pound-inch)
Main Circuit	1	L1, L2, L3, T1, T2, T3, B1/P, B1/R, B2, ⊖	14 ~ 10	M4	10
		⊕	14 ~ 10	M4	10
	2	L1, L2, L3, T1, T2, T3, B1/P, B1/R, B2, ⊖	14 ~ 10	M4	10
		⊕	12 ~ 10	M4	10
	3	L1, L2, L3, T1, T2, T3, B1/P, B1/R, B2, ⊖	12 ~ 10	M4	10
		⊕	12 ~ 10	M4	10
	5	L1, L2, L3, T1, T2, T3, B1/P, B1/R, B2, ⊖	12 ~ 10	M4	10
		⊕	10	M4	10
	7.5	L1, L2, L3, T1, T2, T3, B1/P, B1/R, B2, ⊖	8	M4	10
		⊕	10 ~ 8	M4	10
	10	L1, L2, L3, T1, T2, T3, B1/P, B1/R, B2, ⊖	8	M4	10
		⊕	10 ~ 8	M4	10
	15	L1, L2, L3, T1, T2, T3, B1/P, B2, ⊖	4	M6	35
		⊕	8	M6	35
	20	L1, L2, L3, T1, T2, T3, B1/P, B2, ⊖	2	M6	35
		⊕	8	M6	35
Control Circuit	All series	①~⑧, 15V, VIN, AIN, AUX, AO1, AO2 RA, RB, RC, DO1, DO2, (or R2A, R2C)	24~14	M2.6	4

(D) 460V Class (NEMA4)

Circuit	Inverter Rating (HP)	Terminals Mark	Cable Size (AWG)	Terminals	Tightening Torque (Pound-inch)
Main Circuit	1	L1, L2, L3, T1, T2, T3, B1/P, B1/R, B2, ⊖	14 ~ 10	M4	10
		⊕	14 ~ 10	M4	10
	2	L1, L2, L3, T1, T2, T3, B1/P, B1/R, B2, ⊖	14 ~ 10	M4	10
		⊕	14 ~ 10	M4	10
	3	L1, L2, L3, T1, T2, T3, B1/P, B1/R, B2, ⊖	14 ~ 10	M4	10
		⊕	14 ~ 10	M4	10
	5	L1, L2, L3, T1, T2, T3, B1/P, B1/R, B2, ⊖	14 ~ 10	M4	10
		⊕	12 ~ 10	M4	10
	7.5	L1, L2, L3, T1, T2, T3, B1/P, B1/R, B2, ⊖	12 ~ 10	M4	10
		⊕	12 ~ 10	M4	10
	10	L1, L2, L3, T1, T2, T3, B1/P, B1/R, B2, ⊖	10	M4	10
		⊕	10	M4	10
	15	L1, L2, L3, T1, T2, T3, B1/P, B1/R, B2, ⊖	12 ~ 10	M6	35
		⊕	12 ~ 10	M6	35
	20	L1, L2, L3, T1, T2, T3, B1/P, B1/R, B2, ⊖	10	M6	35
		⊕	10	M6	35
Control Circuit	All series	①~⑧, 15V, VIN, AIN, AUX, AO1, AO2 RA, RB, RC, DO1, DO2, (or R2A, R2C)	24~14	M2.6	4

## H. Spare Parts

### (A) 230V Class (NEMA1)

INVERTER & PARTS NAME			CONTROL PC BOARD	POWER BOARD	Power Module (IGBT)	Diode Module
HP	MODEL	SPEC.				
1	MA7200-2001-N1	MODEL	—	—	CM15MDL-12H	
		CODE	4P101C0120005 *1	4P106C01600A1	277830540	
		Q'TY	1	1	1	
2	MA7200-2002-N1	MODEL	—	—	CM20MDL-12H	
		CODE	4P101C0120005 *1	4P106C0160003	3K3A2471	
		Q'TY	1	1	1	
3	MA7200-2003-N1	MODEL	—	—	7MBR30SA060	
		CODE	4P101C0130001 *2	4P106C01800B1	3K3A2624	
		Q'TY	1	1	1	
5	MA7200-2005-N1	MODEL	—	—	7MBR50SA060	
		CODE	4P101C0130001 *2	4P106C01800C9	3K3A2627	
		Q'TY	1	1	1	
7.5	MA7200-2007-N1	MODEL	—	—	7MBP50RA060	DF75LA80
		CODE	4P101C0130001 *2	4P106C0210001	277831660	4M903D1480016
		Q'TY	1	1	1	1
10	MA7200-2010-N1	MODEL	—	—	7MBP75RA060	DF75LA80
		CODE	4P101C0130001 *2	4P106C0220006	277831678	4M903D1480016
		Q'TY	1	1	1	1
15	MA7200-2015-N1	MODEL	—	—	7MBP100RTA060	DF100BA80
		CODE	4P101C0130001 *2	4P106C01500A6	277831694	277192209
		Q'TY	1	1	1	1
20	MA7200-2020-N1	MODEL	—	—	7MBP160RTA060	DF150BA80
		CODE	4P101C0130001 *2	4P106C01500B4	277831708	277192179
		Q'TY	1	1	1	1
25	MA7200-2025-N1	MODEL	—	—	MIG200J6CMB1W	SKKH42/16E
		CODE	4P101C0130001 *2	4P106C03300B2	277830086	277112311
		Q'TY	1	1	1	3
30	MA7200-2030-N1	MODEL	—	—	SKM195GB063DN	SKKH57/16E
		CODE	4P101C0130001 *2	4P106C04000A2	277810654	277112329
		Q'TY	1	1	3	3
40	MA7200-2040-N1	MODEL	—	—	SKM300GB063DN	SKKH72/16E
		CODE	4P101C0130001 *2	4P106C04000A2	277810662	277112337
		Q'TY	1	1	3	3

\*1 : For old version, code no. is 4P101C0040001.

\*2 : For old version, code no. is 4P101C0060002.

INVERTER & PARTS NAME			COOLING FAN		Resistor	
HP	MODEL	SPEC.				
1	MA7200-2001-N1	MODEL	KD1204PFBX		N20SP-12-Y2	
		CODE	4M903D0880002		3M903D1820000	
		Q'TY	1		1	
2	MA7200-2002-N1	MODEL	KD1204PFBX		N20SP-12-Y2	
		CODE	4M903D0880002		3M903D1820000	
		Q'TY	1		1	
3	MA7200-2003-N1	MODEL	AFB0624H		8W/12Ω	
		CODE	4H300D0190012		4M903D0180086	
		Q'TY	1		2	
5	MA7200-2005-N1	MODEL	AFB0624H		8W/12Ω	
		CODE	4H300D0190012		4M903D0180086	
		Q'TY	1		2	
7.5	MA7200-2007-N1	MODEL	AFB0824VH	8W/6.2Ω	8W/6.2Ω	
		CODE	4H300D0200018	4M903D0180078	4M903D2330018	
		Q'TY	1	1	1	
10	MA7200-2010-N1	MODEL	AFB0824VH	8W/6.2Ω	8W/6.2Ω	
		CODE	4H300D0200018	4M903D0180078	4M903D2330018	
		Q'TY	1	1	1	
15	MA7200-2015-N1	MODEL	AFB0824SH-B		60W/2.2Ω	
		CODE	4H300D3340007		3H300D2350005	
		Q'TY	1		1	
20	MA7200-2020-N1	MODEL	AFB0824SH-B		60W/2.2Ω	
		CODE	4H300D3340007		3H300D2350005	
		Q'TY	1		1	
25	MA7200-2025-N1	MODEL	PMD2408PMB1-A	KD2406PTB1	60W/120Ω	
		CODE	4H300D6050000	4H300D6060013	3K3A4880	
		Q'TY	2	1	1	
30	MA7200-2030-N1	MODEL	PSD2412PMB1	KD2406PTB1	60W/120Ω	
		CODE	4H300D6040004	4H300D6060021	3K3A4880	
		Q'TY	2	1	1	
40	MA7200-2040-N1	MODEL	PSD2412PMB1	KD2406PTB1	60W/120Ω	
		CODE	4H300D6040004	4H300D6060021	3K3A4880	
		Q'TY	2	1	1	

INVERTER & PARTS NAME			Relay	DCCT	Capacitor	OPERATOR
HP	MODEL	SPEC.				
1	MA7200-2001-N1	MODEL	0Z-SS-112LM	LX-7.5	330uF/400V	JNEP-36 <sup>*3</sup>
		CODE	271608055	3K3A2468	3K3A1868	4H300C0050000 <sup>*3</sup>
		Q'TY	1	2	3	1
2	MA7200-2002-N1	MODEL	0Z-SS-112LM	HY-10P	330uF/400V	JNEP-36 <sup>*3</sup>
		CODE	271608055	273014331	3K3A1868	4H300C0050000 <sup>*3</sup>
		Q'TY	1	2	4	1
3	MA7200-2003-N1	MODEL	841-S-1A-D-H-24VDC	SY-15T	470uF/400v	JNEP-36 <sup>*3</sup>
		CODE	271608969	3M903D1420001	4M903D0300022	4H300C0050000 <sup>*3</sup>
		Q'TY	1	3	4	1
5	MA7200-2005-N1	MODEL	841-S-1A-D-H-24VDC	SY-25T2	470uF/400v	JNEP-36 <sup>*3</sup>
		CODE	271608969	3M903D3860009	4M903D0300022	4H300C0050000 <sup>*3</sup>
		Q'TY	1	3	4	1
7.5	MA7200-2007-N1	MODEL	841-S-2A-D-H-24VDC	HY37-P	1500uF/400V	JNEP-36 <sup>*3</sup>
		CODE	271608977	4M903D1020015	4M903D0310010	4H300C0050000 <sup>*3</sup>
		Q'TY	1	3	2	1
10	MA7200-2010-N1	MODEL	841-S-2A-D-H-24VDC	HY50-P	1800uF/400V	JNEP-36 <sup>*3</sup>
		CODE	271608977	4M903D1020023	4M903D0310010	4H300C0050000 <sup>*3</sup>
		Q'TY	1	3	2	1
15	MA7200-2015-N1	MODEL	G7J-4A-B-DC24V	HC-PT075V4B15	3300uF/400V	JNEP-36 <sup>*3</sup>
		CODE	3K3A2390	3M903D4030034	4M903D0310061	4H300C0050000 <sup>*3</sup>
		Q'TY	1	1	2	1
20	MA7200-2020-N1	MODEL	G7J-4A-B-DC24V	HC-PT100V4B15	4400uF/400V	JNEP-36 <sup>*3</sup>
		CODE	3K3A2390	3M903D4030042	4M903D0310052	4H300C0050000 <sup>*3</sup>
		Q'TY	1	1	2	1
25	MA7200-2025-N1	MODEL	942H-2C-24-DS	L08P150D15	400V/6800uF	JNEP-36 <sup>*3</sup>
		CODE	4M903D2800006	4M903D3960031	4M903D4110007	4H300C0050000 <sup>*3</sup>
		Q'TY	1	3	2	1
30	MA7200-2030-N1	MODEL	942H-2C-24-DS	CT/Board	CAP./Board	JNEP-36 <sup>*3</sup>
		CODE	4M903D2800006	4P108C00800A2	4P108C0050008	4H300C0050000 <sup>*3</sup>
		Q'TY	1	1	1	1
40	MA7200-2040-N1	MODEL	942H-2C-24-DS	CT/Board	CAP./Board	JNEP-36 <sup>*3</sup>
		CODE	4M903D2800006	4P108C0090000	4P108C0060003	4H300C0050000 <sup>*3</sup>
		Q'TY	1	1	1	1

\*3 : For old version, code no. is 4H300C0020003 (JNEP-31V).

(B) 460V Class (NEMA1)

INVERTER & PARTS NAME			CONTROL PC BOARD	POWER BOARD	Power Module (IGBT)	Diode Module
HP	MODEL	SPEC.				
1	MA7200-4001-N1	MODEL	—	—	CM10MDL-24H	
		CODE	4P101C0120005 *1	4P106C0250002	3K3A2473	
		Q'TY	1	1	1	
2	MA7200-4002-N1	MODEL	—	—	CM10MDL-24H	
		CODE	4P101C0120005 *1	4P106C02500A1	3K3A2473	
		Q'TY	1	1	1	
3	MA7200-4003-N1	MODEL	—	—	7MBR15SA120	
		CODE	4P101C0130001 *2	4P106C0240007	277831643	
		Q'TY	1	1	1	
5	MA7200-4005-N1	MODEL	—	—	7MBR25SA120	
		CODE	4P101C0130001 *2	4P106C02400A5	277831651	
		Q'TY	1	1	1	
7.5	MA7200-4007-N1	MODEL	—	—	7MBP50RA120	6RI30G-160
		CODE	4P101C0130001 *2	4P106C0110006	277831686	277191067
		Q'TY	1	1	1	1
10	MA7200-4010-N1	MODEL	—	—	7MBP50RA120	6RI30G-160
		CODE	4P101C0130001 *2	4P106C0110006	277831686	277191067
		Q'TY	1	1	1	1
15	MA7200-4015-N1	MODEL	—	—	7MBP75RA120	DF75AA160
		CODE	4P101C0130001 *2	4P106C0150008	277831538	277192128
		Q'TY	1	1	1	
20	MA7200-4020-N1	MODEL	—	—	7MBP75RA120	DF75AA160
		CODE	4P101C0130001 *2	4P106C0150016	277831538	277192128
		Q'TY	1	1	1	1
25	MA7200-4025-N1	MODEL	—	—	MIG100Q6CMB1X	SKKH42/16E
		CODE	4P101C0130001 *2	4P106C0330006	277830094	277112311
		Q'TY	1	1	1	3
30	MA7200-4030-N1	MODEL	—	—	MIG150Q6CMB1X	SKKH42/16E
		CODE	4P101C0130001 *2	4P106C03300A4	277830108	277112311
		Q'TY	1	1	1	3
40	MA7200-4040-N1	MODEL	—	—	SKM145GB128DN	SKKH42/16E
		CODE	4P101C0130001 *2	4P106C0400007	277810620	277112311
		Q'TY	1	1	3	3
50	MA7200-4050-N1	MODEL	—	—	CM200DY-24A	SKKH57/16E
		CODE	4P101C0130001 *2	4P106C0400007	277810336	277112329
		Q'TY	1	1	3	3
60	MA7200-4060-N1	MODEL	—	—	SKM300GB128D	SKKH72/16E
		CODE	4P101C0130001 *2	4P106C0410000	277810646	277112337
		Q'TY	1	1	3	3
75	MA7200-4075-N1	MODEL	—	—	SKM300GB128D	SKKH92/16E
		CODE	4P101C0130001 *2	4P106C0410000	277810646	277112345
		Q'TY	1	1	3	3

\*1 : For old version, code no. is 4P101C0040001.

\*2 : For old version, code no. is 4P101C0060002.

INVERTER & PARTS NAME			COOLING FAN		Resistor	
HP	MODEL	SPEC.				
1	MA7200-4001-N1	MODEL	KD1204PFBX		5W/40Ω	
		CODE	4M903D0880002		3M112Z0010006	
		Q'TY	1		2	
2	MA7200-4002-N1	MODEL	KD1204PFBX		5W/40Ω	
		CODE	4M903D0880002		3M112Z0010006	
		Q'TY	1		2	
3	MA7200-4003-N1	MODEL	AFB0624H		8W/120Ω	
		CODE	4H300D0190004		4M903D0180060	
		Q'TY	1		1	
5	MA7200-4005-N1	MODEL	AFB0624H		8W/120Ω	
		CODE	4H300D0190004		4M903D0180060	
		Q'TY	1		1	
7.5	MA7200-4007-N1	MODEL	AFB0824SH		10W/16Ω	10W/16Ω
		CODE	4H300D0200000		4M903D0190022	4M903D2330026
		Q'TY	1		1	1
10	MA7200-4010-N1	MODEL	AFB0824SH		10W/16Ω	10W/16Ω
		CODE	4H300D0200000		4M903D0190022	4M903D2330026
		Q'TY	1		1	1
15	MA7200-4015-N1	MODEL	AFB0824SH		80W/6.2 Ω	
		CODE	4H300D1440004		3H300D2360001	
		Q'TY	1		1	
20	MA7200-4020-N1	MODEL	AFB0824SH		80W/6.2 Ω	
		CODE	4H300D1440004		3H300D2360001	
		Q'TY	1		1	
25	MA7200-4025-N1	MODEL	EEB0824EHE	ASB0624H-B	60W/240Ω	
		CODE	4H300D5590001	4H300D6060013	3K3A4879	
		Q'TY	2	1	1	
30	MA7200-4030-N1	MODEL	EEB0824EHE	ASB0624H-B	60W/240Ω	
		CODE	4H300D6050000	4H300D6060013	3K3A4879	
		Q'TY	2	1	1	
40	MA7200-4040-N1	MODEL	PSD2412PMB1	KD2406PTB1	60W/240Ω	
		CODE	4H300D6040004	4H300D6060021	3K3A4881	
		Q'TY	2	1	1	
50	MA7200-4050-N1	MODEL	PSD2412PMB1	KD2406PTB1	60W/240Ω	
		CODE	4H300D6040004	4H300D6060021	3K3A4881	
		Q'TY	2	1	1	
60	MA7200-4060-N1	MODEL	PSD2412PMB1	KD2406PTB1	60W/240Ω	
		CODE	4H300D6040004	4H300D6060021	3K3A4881	
		Q'TY	2	1	1	
75	MA7200-4075-N1	MODEL	PSD2412PMB1	KD2406PTB1	60W/240Ω	
		CODE	4H300D6040004	4H300D6060021	3K3A4881	
		Q'TY	2	1	1	

INVERTER & PARTS NAME			Relay	DCCT	Capacitor	OPERATOR
HP	MODEL	SPEC.				
1	MA7200-4001-N1	MODEL	RT444012	TB5A 4V	330uF/400V	JNEP-36 <sup>*3</sup>
		CODE	4M903D1040008	4M903D2210012	3K3A1868	4H300C0050000 <sup>*3</sup>
		Q'TY	1	2	2	1
2	MA7200-4002-N1	MODEL	RT444012	TB5A 4V	330uF/400V	JNEP-36 <sup>*3</sup>
		CODE	4M903D1040008	4M903D2210012	3K3A1868	4H300C0050000 <sup>*3</sup>
		Q'TY	1	2	4	1
3	MA7200-4003-N1	MODEL	953-1A-24DG-DC24V	HC-PSG075V4B15	330uF/400V	JNEP-36 <sup>*3</sup>
		CODE	271603711	4M903D2220026	4M903D0300014	4H300C0050000 <sup>*3</sup>
		Q'TY	1	3	4	1
5	MA7200-4005-N1	MODEL	953-1A-24DG-DC24V	HC-PSG125V4B15	560uF/400V	JNEP-36 <sup>*3</sup>
		CODE	271603711	4M903D2220042	4M903D0300031	4H300C0050000 <sup>*3</sup>
		Q'TY	1	3	4	1
7.5	MA7200-4007-N1	MODEL	841-S-2A-D-H	TC25A 4V	2200uF/400V	JNEP-36 <sup>*3</sup>
		CODE	271608977	4M903D2210063	4M903D0310036	4H300C0050000 <sup>*3</sup>
		Q'TY	1	3	2	1
10	MA7200-4010-N1	MODEL	841-S-2A-D-H	TC25A 4V	2200uF/400V	JNEP-36 <sup>*3</sup>
		CODE	271608977	4M903D2210063	4M903D0310036	4H300C0050000 <sup>*3</sup>
		Q'TY	1	3	2	1
15	MA7200-4015-N1	MODEL	G7J-4A-B-DC24V	HC-PT0375V4B15	3300uF/400V	JNEP-36 <sup>*3</sup>
		CODE	3K3A2390	3M903D4030018	4M903D0310061	4H300C0050000 <sup>*3</sup>
		Q'TY	1	1	2	1
20	MA7200-4020-N1	MODEL	G7J-4A-B-DC24V	HC-PT050V4B15	4400uF/400V	JNEP-36 <sup>*3</sup>
		CODE	3K3A2390	3M903D4030026	4M903D0310052	4H300C0050000 <sup>*3</sup>
		Q'TY	1	1	2	1
25	MA7200-4025-N1	MODEL	942H-2C-24-DS	L08P075D15	400V/6800uF	JNEP-36 <sup>*3</sup>
		CODE	4M903D2800006	4M903D3960015	4M903D4110007	4H300C0050000 <sup>*3</sup>
		Q'TY	1	3	2	1
30	MA7200-4030-N1	MODEL	942H-2C-24-DS	L08P100D15	400V/6800uF	JNEP-36 <sup>*3</sup>
		CODE	4M903D2800006	4M903D3960023	4M903D4110007	4H300C0050000 <sup>*3</sup>
		Q'TY	1	3	2	1
40	MA7200-4040-N1	MODEL	942H-2C-24-DS	CT/Board	CAP./Board	JNEP-36 <sup>*3</sup>
		CODE	4M903D2800006	4P108C0080004	4P108C0040002	4H300C0050000 <sup>*3</sup>
		Q'TY	1	1	1	1
50	MA7200-4050-N1	MODEL	942H-2C-24-DS	CT/Board	CAP./Board	JNEP-36 <sup>*3</sup>
		CODE	4M903D2800006	4P108C00800A2	4P108C00400A1	4H300C0050000 <sup>*3</sup>
		Q'TY	1	1	1	1
60	MA7200-4060-N1	MODEL	942H-2C-24-DS	CT/Board	CAP./Board	JNEP-36 <sup>*3</sup>
		CODE	4M903D2800006	4P108C0100005	4P108C0020001	4H300C0050000 <sup>*3</sup>
		Q'TY	1	1	1	1
75	MA7200-4075-N1	MODEL	942H-2C-24-DS	CT/Board	CAP./Board	JNEP-36 <sup>*3</sup>
		CODE	4M903D2800006	4P108C0100005	4P108C00200A0	4H300C0050000 <sup>*3</sup>
		Q'TY	1	1	1	1

\*3 : For old version, code no. is 4H300C0020003 (JNEP-31V).

(C) 230V Class (NEMA4)

INVERTER & PARTS NAME			Control PC Board	Power Board	Rectifier Board	Main Circuit Transistor
HP	MODEL	SPEC.				
1	MA7200-2001-N4	MODEL	—	—	—	CM15MDL-12H
		CODE	4P101C0120005	4P106C01600A1	—	277830540
		Q'TY	1	1	—	1
2	MA7200-2002-N4	MODEL	—	—	—	CM20MDL-12H
		CODE	4P101C0120005	4P106C0160003	—	277830558
		Q'TY	1	1	—	1
3	MA7200-2003-N4	MODEL	—	—	—	7MBP50RA060
		CODE	4P101C0130001	4P106C04900B0 4P106C05000B5	—	277831660
		Q'TY	1	1	—	1
5	MA7200-2005-N4	MODEL	—	—	—	7MBP50RA060
		CODE	4P101C0130001	4P106C04900B0 4P106C05000B5	—	277831660
		Q'TY	1	1	—	1
7.5	MA7200-2007-N4	MODEL	—	—	—	7MBP50RA060
		CODE	4P101C0130001	4P106C01500C2	4P106C0480008	277831660
		Q'TY	1	1	1	1
10	MA7200-2010-N4	MODEL	—	—	—	7MBP75RA060
		CODE	4P101C0130001	4P106C01500D1	4P106C0480008	277831678
		Q'TY	1	1	1	1
15	MA7200-2015-N4	MODEL	—	—	—	PM100RSE060
		CODE	4P101C0130001	4P106C01500A6	4P106C0470002	277820242
		Q'TY	1	1	1	1
20	MA7200-2020-N4	MODEL	—	—	—	PM150RSE060
		CODE	4P101C0130001	4P106C01500B4	4P106C0470002	277820251
		Q'TY	1	1	1	1

INVERTER & PARTS NAME			Main Circuit Diode	Cooling Fan ( inside )	Cooling Fan ( outside )	Operator
HP	MODEL	SPEC.				
1	MA7200-2001-N4	MODEL	—	KD1204PFBX	—	JNEP-36
		CODE	—	4M903D0880002	—	4P303C00100B7
		Q'TY	—	1	—	1
2	MA7200-2002-N4	MODEL	—	KD1204PFBX	—	JNEP-36
		CODE	—	4M903D0880002	—	4P303C00100B7
		Q'TY	—	1	—	1
3	MA7200-2003-N4	MODEL	DB35-16	AD0424HB-G70(T)	KD2406PTB1	JNEP-36
		CODE	4M903D4410001	4M903D4630001	4M903D4640006	4P303C00100B7
		Q'TY	1	1	2	1
5	MA7200-2005-N4	MODEL	DB35-16	AD0424HB-G70(T)	KD2406PTB1	JNEP-36
		CODE	4M903D4410001	4M903D4630001	4M903D4640006	4P303C00100B7
		Q'TY	1	1	2	1
7.5	MA7200-2007-N4	MODEL	VVZ 70-16	AFB0624H	PMD2408PMB1-A(2)I55	JNEP-36
		CODE	277111331	4H300D0250009	4H300D0190004	4P303C00100B7
		Q'TY	1	1	2	1
10	MA7200-2010-N4	MODEL	VVZ 70-16	AFB0624H	PMD2408PMB1-A(2)I55	JNEP-36
		CODE	277111331	4H300D0250009	4H300D0190004	4P303C00100B7
		Q'TY	1	1	2	1
15	MA7200-2015-N4	MODEL	VVZ110-12	AFB0624H	PMD2408PMB1-A(2)I55	JNEP-36
		CODE	277111314	4H300D0250009	4H300D0190004	4P303C00100B7
		Q'TY	1	1	2	1
20	MA7200-2020-N4	MODEL	VVZ175-12	AFB0624H	PMD2408PMB1-A(2)I55	JNEP-36
		CODE	277111314	4H300D0250009	4H300D0190004	4P303C00100B7
		Q'TY	1	1	2	1

(D) 460V Class (NEMA4)

INVERTER & PARTS NAME			Control PC Board	Power Board	Rectifier Board	Main Circuit Transistor
HP	MODEL	SPEC.				
1	MA7200-4001-N4	MODEL	—	—	—	CM10MDL-24H
		CODE	4P101C0120005	4P106C0250002	—	277840049
		Q'TY	1	1	—	1
2	MA7200-4002-N4	MODEL	—	—	—	CM10MDL-24H
		CODE	4P101C0120005	4P106C02500A1	—	277840049
		Q'TY	1	1	—	1
3	MA7200-4003-N4	MODEL	—	—	—	7MBP25RA120
		CODE	4P101C0130001	4P106C0490011 4P106C0500017	—	277831716
		Q'TY	1	1	—	1
5	MA7200-4005-N4	MODEL	—	—	—	7MBP25RA120
		CODE	4P101C0130001	4P106C0490003 4P106C0500009	—	277831716
		Q'TY	1	1	—	1
7.5	MA7200-4007-N4	MODEL	—	—	—	7MBP50RA120
		CODE	4P101C0130001	4P106C0150016	4P106C0460007	277831686
		Q'TY	1	1	1	1
10	MA7200-4010-N4	MODEL	—	—	—	7MBP50RA120
		CODE	4P101C0130001	4P106C0150016	4P106C0460007	277831686
		Q'TY	1	1	1	1
15	MA7200-4015-N4	MODEL	—	—	—	7MBP75RA120
		CODE	4P101C0130001	4P106C0150008	4P106C0450001	277831538
		Q'TY	1	1	1	1
20	MA7200-4020-N4	MODEL	—	—	—	7MBP75RA120
		CODE	4P101C0130001	4P106C0150016	4P106C0450001	277831538
		Q'TY	1	1	1	1

INVERTER & PARTS NAME			Main Circuit Diode	Cooling Fan ( inside )	Cooling Fan ( outside )	Operator
HP	MODEL	SPEC.				
1	MA7200-4001-N4	MODEL	—	KD1204PFBX	—	JNEP-36
		CODE	—	4M903D0880002	—	4P303C00100B7
		Q'TY	—	1	—	1
2	MA7200-4002-N4	MODEL	—	KD1204PFBX	—	JNEP-36
		CODE	—	4M903D0880002	—	4P303C00100B7
		Q'TY	—	1	—	1
3	MA7200-4003-N4	MODEL	DB35-16	AD0424HB-G70(T)	KD2406PTB1	JNEP-36
		CODE	4M903D4410001	4M903D4630001	4M903D4640006	4P303C00100B7
		Q'TY	1	1	2	1
5	MA7200-4005-N4	MODEL	DB35-16	AD0424HB-G70(T)	KD2406PTB1	JNEP-36
		CODE	4M903D4410001	4M903D4630001	4M903D4640006	4P303C00100B7
		Q'TY	1	1	2	1
7.5	MA7200-4007-N4	MODEL	VVZ40-16	AFB0624H	PMD2408PMB1-A(2)I55	JNEP-36
		CODE	27711349	4H300D0250009	4H300D0190004	4P303C00100B7
		Q'TY	1	1	2	1
10	MA7200-4010-N4	MODEL	VVZ40-16	AFB0624H	PMD2408PMB1-A(2)I55	JNEP-36
		CODE	27711349	4H300D0250009	4H300D0190004	4P303C00100B7
		Q'TY	1	1	2	1
15	MA7200-4015-N4	MODEL	VVZ 70-16	AFB0624H	PMD2408PMB1-A(2)I55	JNEP-36
		CODE	277111331	4H300D0250009	4H300D0190004	4P303C00100B7
		Q'TY	1	1	2	1
20	MA7200-4020-N4	MODEL	VVZ 70-16	AFB0624H	PMD2408PMB1-A(2)I55	JNEP-36
		CODE	277111331	4H300D0250009	4H300D0190004	4P303C00100B7
		Q'TY	1	1	2	1

## I. Electrical Ratings For Constant Torque and Quadratic Torque

MA7200 Model	Constant Torque (150%, 1minute)			Quadratic Torque (110%, 1minute)		
	Max. Applic. Motor Output HP (kW)	Rated Output Current (A)	Max. Switching Freq. (kHz)	Max. Applic. Motor Output HP (kW)	Rated Output Current (A)	Max. Switching Freq. (kHz)
MA7200-2001-N1	1 (0.75)	4.8 A	15	1 (0.75)	5.6 A	10
MA7200-2002-N1	2 (1.5)	6.4 A	15	2 (1.5)	7.6 A	5
MA7200-2003-N1	3 (2.2)	9.6 A	15	3 (2.2)	9.8 A	15
MA7200-2005-N1	5.4 (4)	17.5 A	15	7.5 (5.5)	22.7 A	5
MA7200-2007-N1	7.5 (5.5)	24 A	15	10 (7.5)	32 A	10
MA7200-2010-N1	10 (7.5)	32 A	15	10 (7.5)	32 A	15
MA7200-2015-N1	15 (11)	48 A	10	20 (15)	56.7 A	5
MA7200-2020-N1	20 (15)	64 A	10	25 (18.5)	70.9 A	5
MA7200-2025-N1	25 (18.5)	80 A	10	25 (18.5)	80 A	10
MA7200-2030-N1	30 (22)	96 A	10	40 (30)	108 A	5
MA7200-2040-N1	40 (30)	130 A	10	40 (30)	130 A	10
MA7200-4001-N1	1 (0.75)	2.6 A	15	1 (0.75)	2.9 A	5
MA7200-4002-N1	2 (1.5)	4 A	15	2 (1.5)	4.6 A	5
MA7200-4003-N1	3 (2.2)	4.8 A	15	3 (2.2)	4.9 A	15
MA7200-4005-N1	5.4 (4)	8.7 A	15	7.5 (5.5)	12.5 A	5
MA7200-4007-N1	7.5 (5.5)	12 A	15	10 (7.5)	15.4 A	10
MA7200-4010-N1	10 (7.5)	15 A	15	15 (11)	22.7 A	5
MA7200-4015-N1	15 (11)	24 A	10	20 (15)	30.3 A	5
MA7200-4020-N1	20 (15)	32 A	10	25 (18.5)	38 A	5
MA7200-4025-N1	25 (18.5)	40 A	10	30 (22)	44 A	5
MA7200-4030-N1	30 (22)	48 A	10	30 (22)	48 A	10
MA7200-4040-N1	40 (30)	64 A	10	50 (37)	71 A	5
MA7200-4050-N1	50 (37)	80 A	10	50 (37)	80 A	10
MA7200-4060-N1	60 (45)	96 A	10	75 (55)	108 A	5
MA7200-4075-N1	75 (55)	128 A	10	100 (75)	140 A	5

Item	Common details	
	Constant Torque	Quadratic Torque
Output Overload	150% for 60s	110% for 60s
Operation Ambient Temperature	+14 ~ 104°F	+14 ~ 104°F
Allowable Voltage Fluctuation	-15% ~ +10%	-15% ~ +10%
Output Frequency	0.5Hz ~ 400Hz	0.5Hz ~ 400Hz
V/F curve	Dependent on parameter setting	Quadratic (or Cubic) Torque

## J. Inverter Heat Loss

### (A) 200 to 230V

Model MA7200- XXXX-N1		2001	2002	2003	2005	2007	2010	2015	2020	2025	2030	2040
Inverter Capacity kVA		2	2.7	4	7.5	10.1	13.7	20.6	27.4	34	41	54
Rated Current A		4.8	6.4	9.6	17.5	24	32	48	64	80	96	130
Heat Loss W	Fin	11	13	30	40	66	77	86	121	145	246	335
	Inside Unit	65	77	185	248	409	474	529	742	889	1510	2059
	Total Heat Loss	76	90	215	288	475	551	615	863	1034	1756	2394

### (B) 380 to 460V

Model MA7200- XXXX-N1		4001	4002	4003	4005	4007	4010	4015	4020	4025	4030	4040	4050	4060	4075
Inverter Capacity kVA		2.2	3.4	4.1	7.5	10.3	12.3	20.6	27.4	34	41	54	68	82	110
Rated Current A		2.6	4	4.8	8.7	12	15	24	32	40	48	64	80	96	128
Heat Loss W	Fin	16	21	41	45	64	72	126	157	198	236	262	324	369	481
	Inside Unit	99	129	249	278	393	442	772	965	1218	1449	1608	1993	2270	2957
	Total Heat Loss	115	150	290	323	457	514	898	1122	1416	1685	1870	2317	2639	3438

**DISTRIBUTED BY:**



5100 NORTH IH-35, ROUND ROCK, TEXAS 78681  
[www.tecowestinghouse.com](http://www.tecowestinghouse.com)

03/01/2006