

FEATURES

- **Controlled Baseline**
 - One Assembly Site
 - One Test Site
 - One Fabrication Site
- **Extended Temperature Performance of –55°C to 125°C**
- **Enhanced Diminishing Manufacturing Sources (DMS) Support**
- **Enhanced Product-Change Notification**
- **Qualification Pedigree ⁽¹⁾**
- **Bidirectional Voltage Translator**
- **4.5 V to 5.5 V on A Port and 2.7 V to 5.5 V on B Port**
- **Control Inputs V_{IH}/V_{IL} Levels Are Referenced to V_{CCA} Voltage**
- **Latch-Up Performance Exceeds 250 mA Per JESD 17**
- **ESD Protection Exceeds JESD 22**
 - 2000-V Human-Body Model (A114-A)
 - 200-V Machine Model (A115-A)
 - 1000-V Charged-Device Model (C101)

(1) Component qualification in accordance with JEDEC and industry standards to ensure reliable operation over an extended temperature range. This includes, but is not limited to, Highly Accelerated Stress Test (HAST) or biased 85/85, temperature cycle, autoclave or unbiased HAST, electromigration, bond intermetallic life, and mold compound life. Such qualification testing should not be viewed as justifying use of this component beyond specified performance and environmental limits.

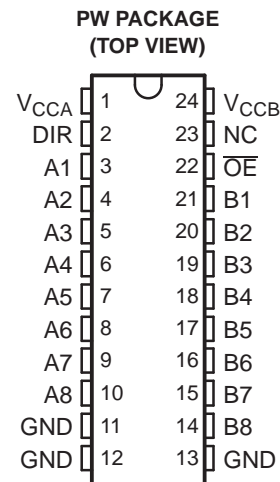

NC – No internal connection

DESCRIPTION/ORDERING INFORMATION

The SN74LVCC4245A is an 8-bit (octal) noninverting bus transceiver that uses two separate power-supply rails. The A port (V_{CCA}) is dedicated to accepting a 5-V supply level, and the configurable B port, which is designed to track V_{CCB} , accepts voltages from 3 V to 5 V. This allows for translation from a 3.3-V to a 5-V environment and vice versa.

The SN74LVCC4245A is designed for asynchronous communication between data buses. The device transmits data from the A bus to the B bus or from the B bus to the A bus, depending on the logic level at the direction-control (DIR) input. The output-enable (\overline{OE}) input can be used to disable the device so the buses effectively are isolated. The control circuitry (DIR, \overline{OE}) is powered by V_{CCA} .

ORDERING INFORMATION⁽¹⁾

T _A	PACKAGE ⁽²⁾		ORDERABLE PART NUMBER	TOP-SIDE MARKING
–55 °C to 125 °C	TSSOP – PW	Reel of 2000	CLVCC4245AMPWREP	LG245A-EP

(1) For the most current package and ordering information, see the Package Option Addendum at the end of this document, or see the TI Web site at www.ti.com.

(2) Package drawings, standard packing quantities, thermal data, symbolization, and PCB design guidelines are available at www.ti.com/sc/package.



Please be aware that an important notice concerning availability, standard warranty, and use in critical applications of Texas Instruments semiconductor products and disclaimers thereto appears at the end of this data sheet.

SN74LVCC4245A-EP
OCTAL DUAL-SUPPLY BUS TRANSCEIVER
WITH CONFIGURABLE OUTPUT VOLTAGE AND 3-STATE OUTPUTS

SCAS830–MARCH 2007

FUNCTION TABLE
(EACH TRANSCEIVER)

INPUTS		OPERATION
\overline{OE}	DIR	
L	L	B data to A bus
L	H	A data to B bus
H	X	Isolation

LOGIC DIAGRAM (POSITIVE LOGIC)

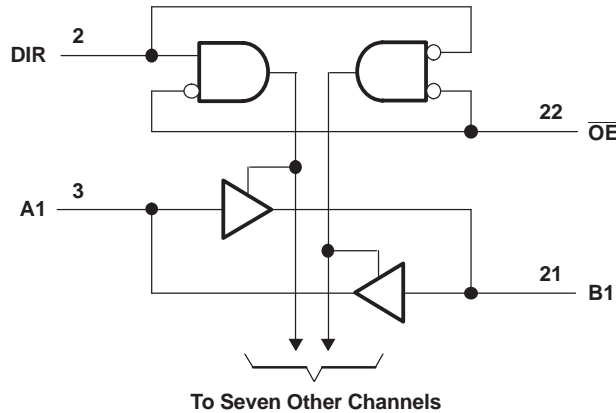

Absolute Maximum Ratings⁽¹⁾

over operating free-air temperature range (unless otherwise noted)

		MIN	MAX	UNIT	
V_{CCA} V_{CCB}	Supply voltage range	-0.5	6	V	
V_I	Input voltage range ⁽²⁾	I/O ports (A port)	-0.5	$V_{CCA} + 0.5$	V
		I/O ports (B port)	-0.5	$V_{CCB} + 0.5$	
		Except I/O ports	-0.5	$V_{CCA} + 0.5$	
V_O	Output voltage range ⁽²⁾	A port	-0.5	$V_{CCA} + 0.5$	V
		B port	-0.5	$V_{CCB} + 0.5$	
I_{IK}	Input clamp current		$V_I < 0$ V	-50	mA
I_{OK}	Output clamp current		$V_O < 0$ V	-50	mA
I_O	Continuous output current			±50	mA
	Continuous current through V_{CCA} , V_{CCB} , or GND			±100	mA
θ_{JA}	Package thermal impedance ⁽³⁾			88	°C/W
T_{stg}	Storage temperature range	-65	150		°C

(1) Stresses beyond those listed under "absolute maximum ratings" may cause permanent damage to the device. These are stress ratings only, and functional operation of the device at these or any other conditions beyond those indicated under "recommended operating conditions" is not implied. Exposure to absolute-maximum-rated conditions for extended periods may affect device reliability.

(2) This value is limited to 6 V maximum.

(3) The package thermal impedance is calculated in accordance with JESD 51-7.

Recommended Operating Conditions⁽¹⁾

		V_{CCA}	V_{CCB}	MIN	NOM	MAX	UNIT
V_{CCA}	Supply voltage			4.5	5	5.5	V
V_{CCB}				2.7	3.3	5.5	
V_{IHA}	High-level input voltage	4.5 V	2.7 V	2			V
			3.6 V	2			
		5.5 V	5.5 V	2			
V_{IHB}	High-level input voltage	4.5 V	2.7 V	2			V
			3.6 V	2			
		5.5 V	5.5 V	3.85			
V_{ILA}	Low-level input voltage	4.5 V	2.7 V			0.8	V
			3.6 V			0.8	
		5.5 V	5.5 V			0.8	
V_{ILB}	Low-level input voltage	4.5 V	2.7 V			0.8	V
			3.6 V			0.8	
		5.5 V	5.5 V			1.65	
V_{IH}	High-level input voltage (control pins) (referenced to V_{CCA})	4.5 V	2.7 V	2			V
			3.6 V	2			
		5.5 V	5.5 V	2			
V_{IL}	Low-level input voltage (control pins) (referenced to V_{CCA})	4.5 V	2.7 V			0.8	V
			3.6 V			0.8	
		5.5 V	5.5 V			0.8	
V_{IA}	Input voltage			0		V_{CCA}	V
V_{IB}	Input voltage			0		V_{CCB}	V
V_{OA}	Output voltage			0		V_{CCA}	V
V_{OB}	Output voltage			0		V_{CCB}	V
I_{OHA}	High-level output current	4.5 V	3 V			–24	mA
I_{OHB}	High-level output current	4.5 V	2.7 V to 4.5 V			–24	mA
I_{OLA}	Low-level output current	4.5 V	3 V			24	mA
I_{OLB}	Low-level output current	4.5 V	2.7 V to 4.5 V			24	mA
T_A	Operating free-air temperature			–55		125	°C

(1) All unused inputs of the device must be held at the associated V_{CC} or GND to ensure proper device operation. See the TI application report, *Implications of Slow or Floating CMOS Inputs*, literature number SCBA004.

SN74LVCC4245A-EP

OCTAL DUAL-SUPPLY BUS TRANSCEIVER

WITH CONFIGURABLE OUTPUT VOLTAGE AND 3-STATE OUTPUTS

SCAS830–MARCH 2007

Electrical Characteristics

over recommended operating free-air temperature range (unless otherwise noted)

PARAMETER		TEST CONDITIONS	V _{CCA}	V _{CCB}	MIN	TYP	MAX	UNIT
V _{OHA}		I _{OH} = -100 μA	4.5 V	3 V	4.4	4.49		V
		I _{OH} = -24 mA			3.76	4.25		
V _{OHB}		I _{OH} = -100 μA	4.5 V	3 V	2.9	2.99		V
		I _{OH} = -12 mA	4.5 V	2.7 V	2.2	2.5		
				3 V	2.46	2.85		
		I _{OH} = -24 mA	4.5 V	2.7 V	2.1	2.3		
				3 V	2.25	2.65		
4.5 V	3.76	4.25						
V _{OLA}		I _{OL} = 100 μA	4.5 V	3 V			0.1	V
		I _{OL} = 24 mA			0.21	0.44		
V _{OLB}		I _{OL} = 100 μA	4.5 V	3 V			0.1	V
		I _{OL} = 12 mA	4.5 V	2.7 V	0.11	0.44		
				3 V	0.22	0.5		
		I _{OL} = 24 mA	4.5 V	3 V	0.21	0.44		
4.5 V	0.18			0.44				
I _I	Control inputs	V _I = V _{CCA} or GND	5.5 V	3.6 V	±0.1	±1	μA	
				5.5 V	±0.1	±1		
I _{OZ} ⁽¹⁾	A or B port	V _O = V _{CCA/B} or GND, V _I = V _{IL} or V _{IH}	5.5 V	3.6 V	±0.5	±5	μA	
I _{CCA}	B to A	A _n = V _{CC} or GND	5.5 V	Open	8	80	μA	
		I _O (A port) = 0, B _n = V _{CCB} or GND	5.5 V	3.6 V	8	80		
I _{CCB}	A to B	A _n = V _{CCA} or GND, I _O (B port) = 0	5.5 V	3.6 V	5	50	μA	
				5.5 V	8	80		
ΔI _{CCA} ⁽²⁾	A port	V _I = V _{CCA} - 2.1 V, Other inputs at V _{CCA} or GND, \overline{OE} at GND and DIR at V _{CCA}	5.5 V	5.5 V	1.35	1.5	mA	
	\overline{OE}	V _I = V _{CCA} - 2.1 V, Other inputs at V _{CCA} or GND, DIR at V _{CCA} or GND	5.5 V	5.5 V	1	1.5		
	DIR	V _I = V _{CCA} - 2.1 V, Other inputs at V _{CCA} or GND, \overline{OE} at V _{CCA} or GND	5.5 V	3.6 V	1	1.5		
ΔI _{CCB} ⁽²⁾	B port	V _I = V _{CCB} - 0.6 V, Other inputs at V _{CCB} or GND, \overline{OE} at GND and DIR at GND	5.5 V	3.6 V	0.35	0.5	mA	
C _i	Control inputs	V _I = V _{CCA} or GND	Open	Open	5		pF	
C _{io}	A or B port	V _O = V _{CCA/B} or GND	5 V	3.3 V	11		pF	

(1) For I/O ports, the parameter I_{OZ} includes the input leakage current.

(2) This is the increase in supply current for each input that is at one of the specified TTL voltage levels, rather than 0 V or the associated V_{CC}.

Switching Characteristics

over recommended operating free-air temperature range, $C_L = 50$ pF (unless otherwise noted) (see [Figure 1](#) through [Figure 4](#))

PARAMETER	FROM (INPUT)	TO (OUTPUT)	$V_{CCA} = 5\text{ V} \pm 0.5\text{ V},$ $V_{CCB} = 5\text{ V} \pm 0.5\text{ V}$		$V_{CCA} = 5\text{ V} \pm 0.5\text{ V},$ $V_{CCB} = 2.7\text{ V to } 3.6\text{ V}$		UNIT
			MIN	MAX	MIN	MAX	
t_{PHL}	A	B	1	7.1	1	7	ns
t_{PLH}			1	6	1	7	
t_{PHL}	B	A	1	6.8	1	6.2	ns
t_{PLH}			1	6.1	1	5.3	
t_{PZL}	\overline{OE}	A	1	9	1	9	ns
t_{PZH}			1	8.3	1	8	
t_{PZL}	\overline{OE}	B	1	8.2	1	10	ns
t_{PZH}			1	8.1	1	10.2	
t_{PLZ}	\overline{OE}	A	1	5.5	1	5.9	ns
t_{PHZ}			1	5.7	1	5.9	
t_{PLZ}	\overline{OE}	B	1	6.4	1	6.4	ns
t_{PHZ}			1	7.8	1	8.9	

Operating Characteristics

$V_{CCA} = 5\text{ V}, V_{CCB} = 3.3\text{ V}, T_A = 25\text{ }^\circ\text{C}$

PARAMETER		TEST CONDITIONS	TYP	UNIT
C_{pd}	Power dissipation capacitance per transceiver	Outputs enabled	20	pF
		Outputs disabled	6.5	

Power-Up Considerations⁽¹⁾

TI level-translation devices offer an opportunity for successful mixed-voltage signal design. A proper power-up sequence should always be followed to avoid excessive supply current, bus contention, oscillations, or other anomalies caused by improperly biased device pins. Take the following precautions to guard against such power-up problems:

1. Connect ground before any supply voltage is applied.
2. Power up the control side of the device (V_{CCA} for all four of these devices).
3. Tie \overline{OE} to V_{CCA} with a pullup resistor so that it ramps with V_{CCA} .
4. Depending on the direction of the data path, DIR can be high or low. If DIR high is needed (A data to B bus), ramp it with V_{CCA} . Otherwise, keep DIR low.

(1) See the TI application report, *Texas Instruments Voltage-Level-Translation Devices*, literature number SCEA021.

SN74LVCC4245A-EP
OCTAL DUAL-SUPPLY BUS TRANSCEIVER
WITH CONFIGURABLE OUTPUT VOLTAGE AND 3-STATE OUTPUTS

SCAS830–MARCH 2007

PARAMETER MEASUREMENT INFORMATION FOR A TO B
 $V_{CCA} = 4.5\text{ V to }5.5\text{ V}$ and $V_{CCB} = 2.7\text{ V to }3.6\text{ V}$

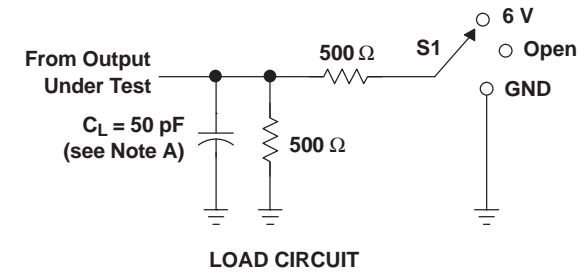

TEST	S1
t_{PLH}/t_{PHL}	Open
t_{PLZ}/t_{PZL}	6 V
t_{PHZ}/t_{PZH}	GND

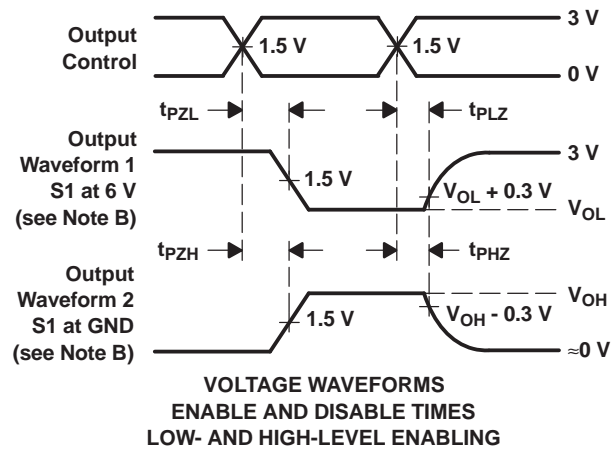
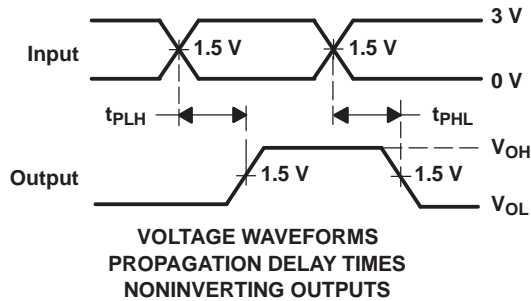
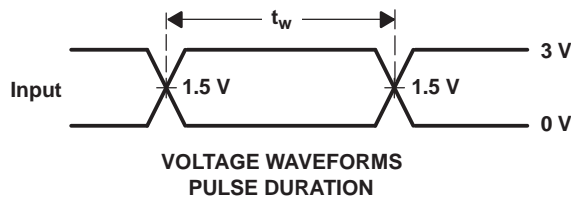

- NOTES: A. C_L includes probe and jig capacitance.
B. Waveform 1 is for an output with internal conditions such that the output is low, except when disabled by the output control. Waveform 2 is for an output with internal conditions such that the output is high, except when disabled by the output control.
C. All input pulses are supplied by generators having the following characteristics: $PRR \leq 10\text{ MHz}$, $Z_O = 50\ \Omega$, $t_r \leq 2.5\text{ ns}$, $t_f \leq 2.5\text{ ns}$.
D. The outputs are measured one at a time, with one transition per measurement.
E. All parameters and waveforms are not applicable to all devices.

Figure 1. Load Circuit and Voltage Waveforms

PARAMETER MEASUREMENT INFORMATION FOR A TO B
 $V_{CCA} = 4.5\text{ V to }5.5\text{ V}$ and $V_{CCB} = 3.6\text{ V to }5.5\text{ V}$

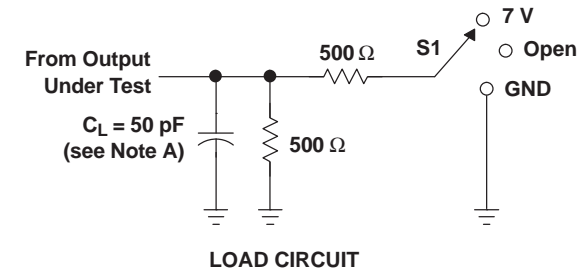

TEST	S1
t_{PLH}/t_{PHL}	Open
t_{PLZ}/t_{PZL}	7 V
t_{PHZ}/t_{PZH}	GND

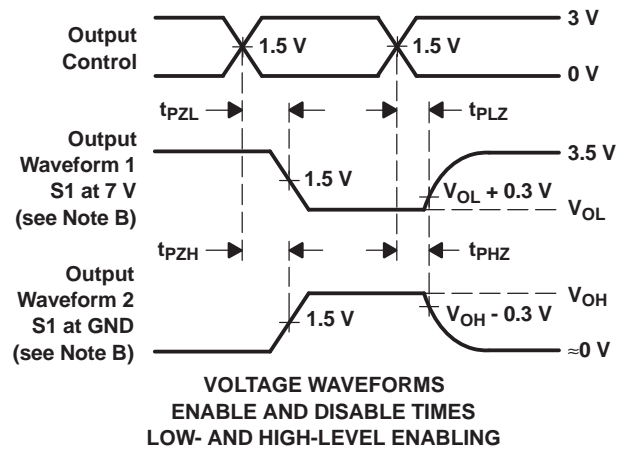
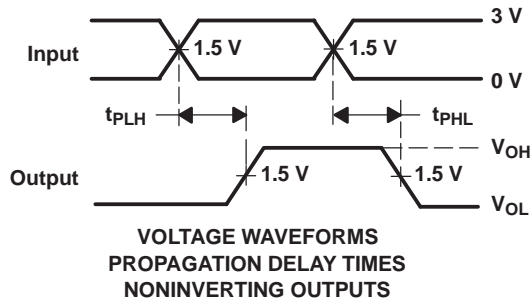
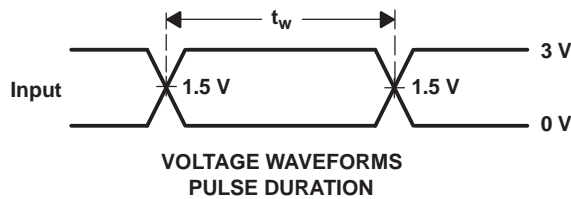

- NOTES: A. C_L includes probe and jig capacitance.
 B. Waveform 1 is for an output with internal conditions such that the output is low, except when disabled by the output control. Waveform 2 is for an output with internal conditions such that the output is high, except when disabled by the output control.
 C. All input pulses are supplied by generators having the following characteristics: $PRR \leq 10\text{ MHz}$, $Z_O = 50\ \Omega$, $t_r \leq 2.5\text{ ns}$, $t_f \leq 2.5\text{ ns}$.
 D. The outputs are measured one at a time, with one transition per measurement.
 E. All parameters and waveforms are not applicable to all devices.

Figure 2. Load Circuit and Voltage Waveforms

PARAMETER MEASUREMENT INFORMATION FOR B TO A
 $V_{CCA} = 4.5\text{ V to }5.5\text{ V}$ and $V_{CCB} = 2.7\text{ V to }3.6\text{ V}$

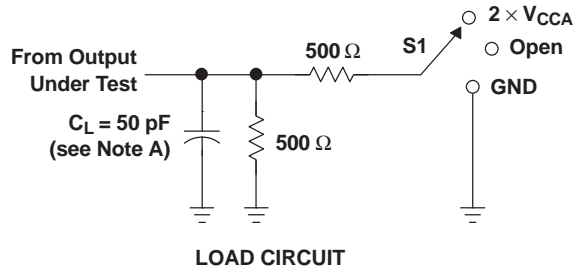

TEST	S1
t_{PLH}/t_{PHL}	Open
t_{PLZ}/t_{PZL}	2 $\times V_{CCA}$
t_{PHZ}/t_{PZH}	GND

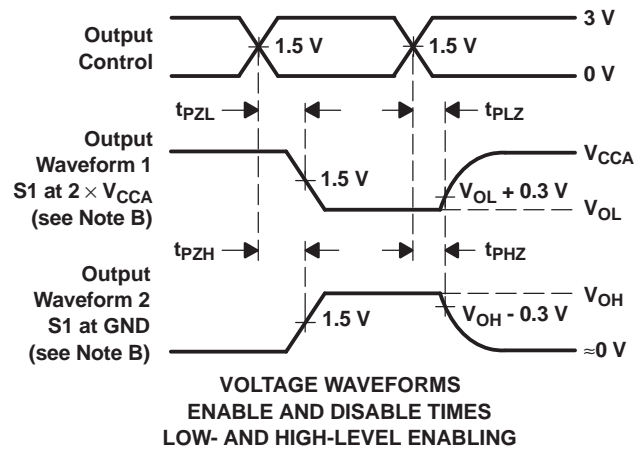
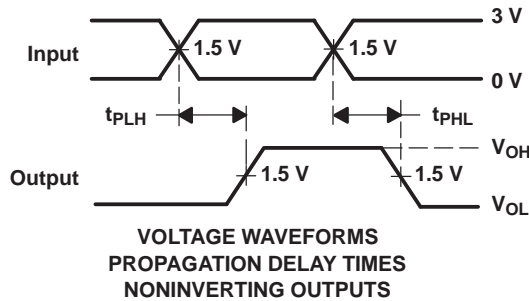
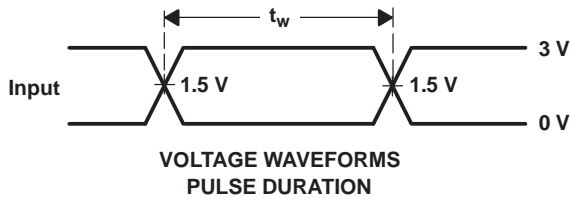

- NOTES: A. C_L includes probe and jig capacitance.
B. Waveform 1 is for an output with internal conditions such that the output is low, except when disabled by the output control. Waveform 2 is for an output with internal conditions such that the output is high, except when disabled by the output control.
C. All input pulses are supplied by generators having the following characteristics: PRR $\leq 10\text{ MHz}$, $Z_O = 50\ \Omega$, $t_r \leq 2.5\text{ ns}$, $t_f \leq 2.5\text{ ns}$.
D. The outputs are measured one at a time, with one transition per measurement.
E. All parameters and waveforms are not applicable to all devices.

Figure 3. Load Circuit and Voltage Waveforms

PARAMETER MEASUREMENT INFORMATION FOR B TO A
 $V_{CCA} = 4.5\text{ V to }5.5\text{ V}$ and $V_{CCB} = 3.6\text{ V to }5.5\text{ V}$

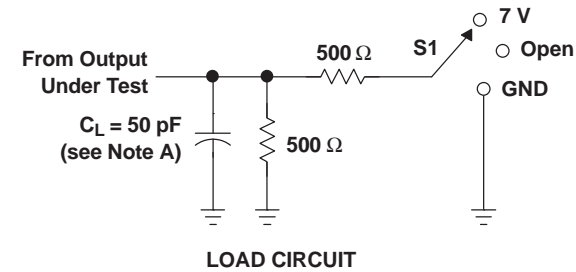

TEST	S1
t_{PLH}/t_{PHL}	Open
t_{PLZ}/t_{PZL}	7 V
t_{PHZ}/t_{PZH}	GND

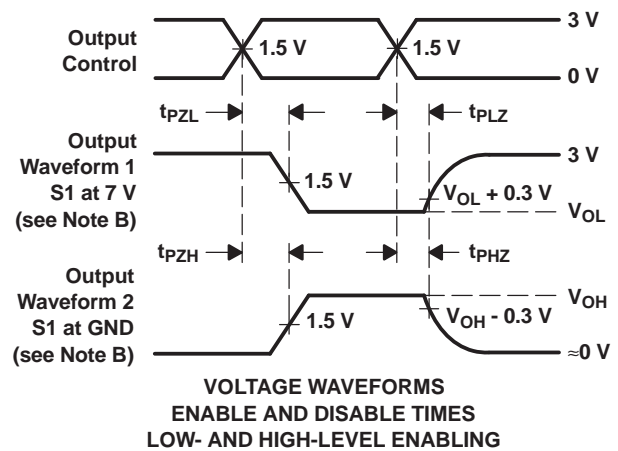
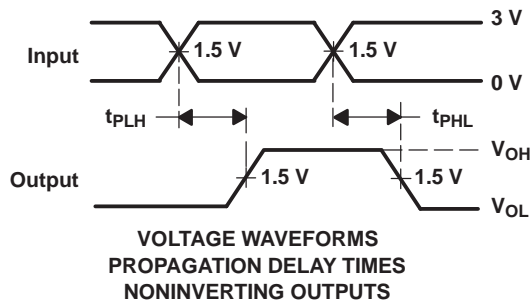
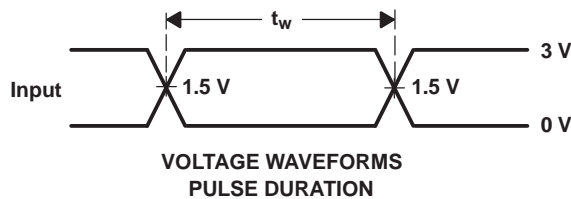

- NOTES: A. C_L includes probe and jig capacitance.
 B. Waveform 1 is for an output with internal conditions such that the output is low, except when disabled by the output control. Waveform 2 is for an output with internal conditions such that the output is high, except when disabled by the output control.
 C. All input pulses are supplied by generators having the following characteristics: $PRR \leq 10\text{ MHz}$, $Z_O = 50\ \Omega$, $t_r \leq 2.5\text{ ns}$, $t_f \leq 2.5\text{ ns}$.
 D. The outputs are measured one at a time, with one transition per measurement.
 E. All parameters and waveforms are not applicable to all devices.

Figure 4. Load Circuit and Voltage Waveforms

PACKAGING INFORMATION

Orderable Device	Status (1)	Package Type	Package Drawing	Pins	Package Qty	Eco Plan (2)	Lead/Ball Finish (6)	MSL Peak Temp (3)	Op Temp (°C)	Device Marking (4/5)	Samples
CLVCC4245AMPWREP	ACTIVE	TSSOP	PW	24	2000	Green (RoHS & no Sb/Br)	CU NIPDAU	Level-1-260C-UNLIM	-55 to 125	LG245A-EP	Samples
CLVCC4245AMPWREPG4	ACTIVE	TSSOP	PW	24	2000	Green (RoHS & no Sb/Br)	CU NIPDAU	Level-1-260C-UNLIM	-55 to 125	LG245A-EP	Samples
V62/06658-01XE	ACTIVE	TSSOP	PW	24	2000	Green (RoHS & no Sb/Br)	CU NIPDAU	Level-1-260C-UNLIM	-55 to 125	LG245A-EP	Samples

(1) The marketing status values are defined as follows:

ACTIVE: Product device recommended for new designs.

LIFEBUY: TI has announced that the device will be discontinued, and a lifetime-buy period is in effect.

NRND: Not recommended for new designs. Device is in production to support existing customers, but TI does not recommend using this part in a new design.

PREVIEW: Device has been announced but is not in production. Samples may or may not be available.

OBSOLETE: TI has discontinued the production of the device.

(2) Eco Plan - The planned eco-friendly classification: Pb-Free (RoHS), Pb-Free (RoHS Exempt), or Green (RoHS & no Sb/Br) - please check <http://www.ti.com/productcontent> for the latest availability information and additional product content details.

TBD: The Pb-Free/Green conversion plan has not been defined.

Pb-Free (RoHS): TI's terms "Lead-Free" or "Pb-Free" mean semiconductor products that are compatible with the current RoHS requirements for all 6 substances, including the requirement that lead not exceed 0.1% by weight in homogeneous materials. Where designed to be soldered at high temperatures, TI Pb-Free products are suitable for use in specified lead-free processes.

Pb-Free (RoHS Exempt): This component has a RoHS exemption for either 1) lead-based flip-chip solder bumps used between the die and package, or 2) lead-based die adhesive used between the die and leadframe. The component is otherwise considered Pb-Free (RoHS compatible) as defined above.

Green (RoHS & no Sb/Br): TI defines "Green" to mean Pb-Free (RoHS compatible), and free of Bromine (Br) and Antimony (Sb) based flame retardants (Br or Sb do not exceed 0.1% by weight in homogeneous material)

(3) MSL, Peak Temp. - The Moisture Sensitivity Level rating according to the JEDEC industry standard classifications, and peak solder temperature.

(4) There may be additional marking, which relates to the logo, the lot trace code information, or the environmental category on the device.

(5) Multiple Device Markings will be inside parentheses. Only one Device Marking contained in parentheses and separated by a "~" will appear on a device. If a line is indented then it is a continuation of the previous line and the two combined represent the entire Device Marking for that device.

(6) Lead/Ball Finish - Orderable Devices may have multiple material finish options. Finish options are separated by a vertical ruled line. Lead/Ball Finish values may wrap to two lines if the finish value exceeds the maximum column width.

Important Information and Disclaimer: The information provided on this page represents TI's knowledge and belief as of the date that it is provided. TI bases its knowledge and belief on information provided by third parties, and makes no representation or warranty as to the accuracy of such information. Efforts are underway to better integrate information from third parties. TI has taken and

continues to take reasonable steps to provide representative and accurate information but may not have conducted destructive testing or chemical analysis on incoming materials and chemicals. TI and TI suppliers consider certain information to be proprietary, and thus CAS numbers and other limited information may not be available for release.

In no event shall TI's liability arising out of such information exceed the total purchase price of the TI part(s) at issue in this document sold by TI to Customer on an annual basis.

OTHER QUALIFIED VERSIONS OF SN74LVCC4245A-EP :

- Catalog: [SN74LVCC4245A](#)

NOTE: Qualified Version Definitions:

- Catalog - TI's standard catalog product

TAPE AND REEL INFORMATION
REEL DIMENSIONS

TAPE DIMENSIONS

A0	Dimension designed to accommodate the component width
B0	Dimension designed to accommodate the component length
K0	Dimension designed to accommodate the component thickness
W	Overall width of the carrier tape
P1	Pitch between successive cavity centers

TAPE AND REEL INFORMATION

*All dimensions are nominal

Device	Package Type	Package Drawing	Pins	SPQ	Reel Diameter (mm)	Reel Width W1 (mm)	A0 (mm)	B0 (mm)	K0 (mm)	P1 (mm)	W (mm)	Pin1 Quadrant
CLVCC4245AMPWREP	TSSOP	PW	24	2000	330.0	16.4	6.95	8.3	1.6	8.0	16.0	Q1

TAPE AND REEL BOX DIMENSIONS



*All dimensions are nominal

Device	Package Type	Package Drawing	Pins	SPQ	Length (mm)	Width (mm)	Height (mm)
CLVCC4245AMPWREP	TSSOP	PW	24	2000	367.0	367.0	38.0



MECHANICAL DATA

PW (R-PDSO-G24)

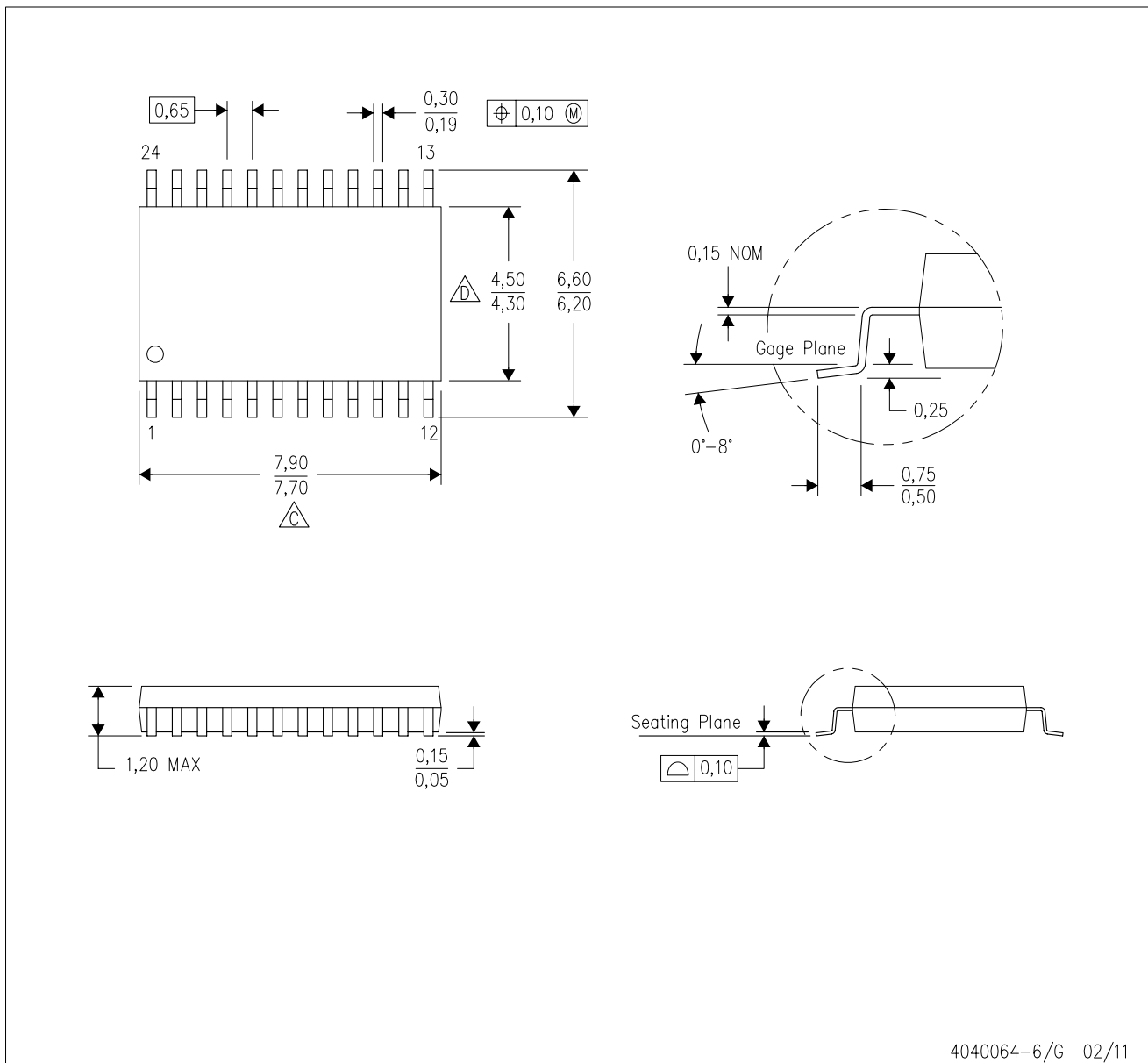
PLASTIC SMALL OUTLINE



4040064-6/G 02/11

- NOTES:
- A. All linear dimensions are in millimeters. Dimensioning and tolerancing per ASME Y14.5M-1994.
 - B. This drawing is subject to change without notice.
 -  C. Body length does not include mold flash, protrusions, or gate burrs. Mold flash, protrusions, or gate burrs shall not exceed 0,15 each side.
 -  D. Body width does not include interlead flash. Interlead flash shall not exceed 0,25 each side.
 - E. Falls within JEDEC MO-153

PW (R-PDSO-G24)

PLASTIC SMALL OUTLINE

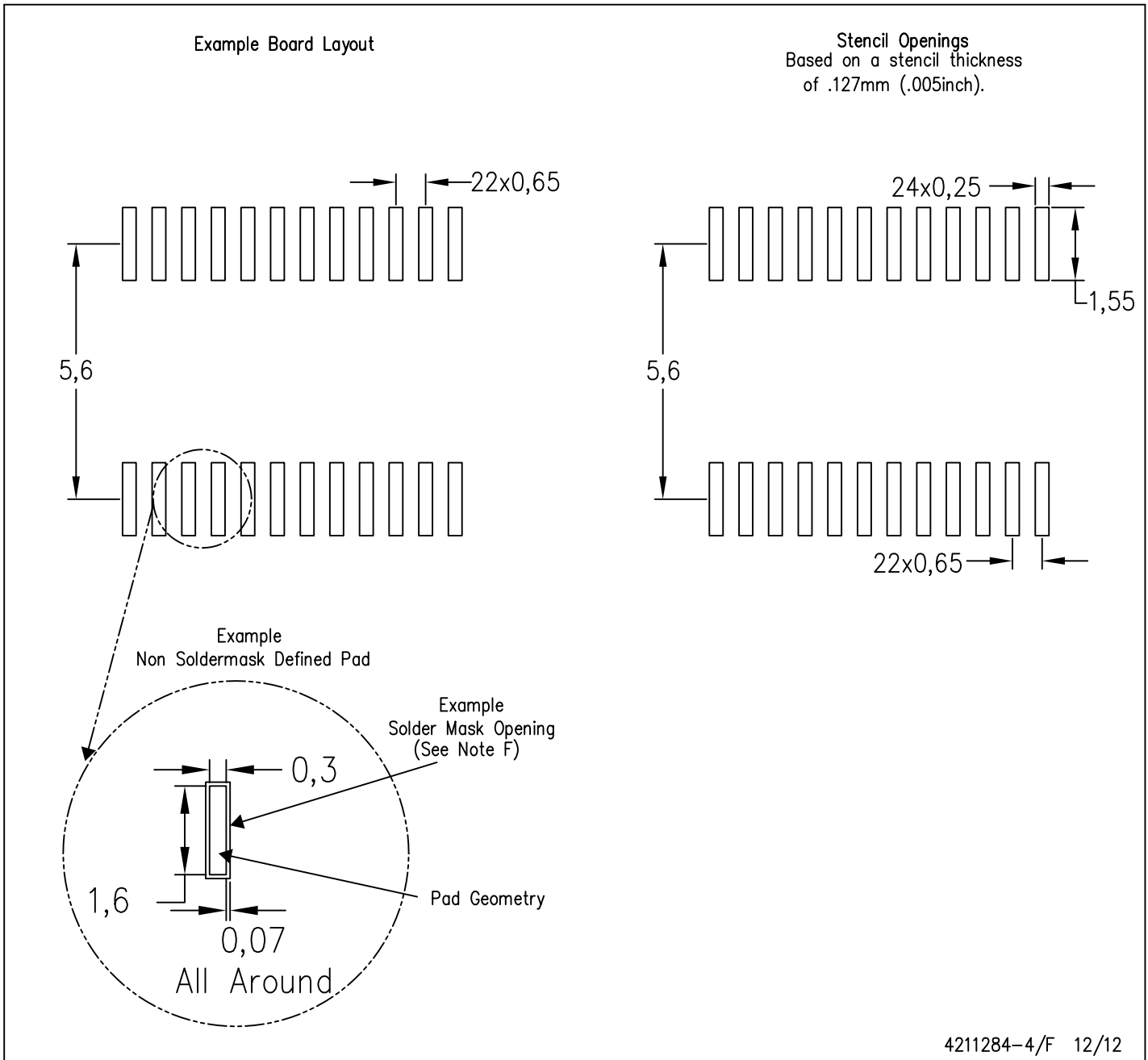

- NOTES:
- A. All linear dimensions are in millimeters.
 - B. This drawing is subject to change without notice.
 - C. Publication IPC-7351 is recommended for alternate design.
 - D. Laser cutting apertures with trapezoidal walls and also rounding corners will offer better paste release. Customers should contact their board assembly site for stencil design recommendations. Refer to IPC-7525 for other stencil recommendations.
 - E. Customers should contact their board fabrication site for solder mask tolerances between and around signal pads.

IMPORTANT NOTICE

Texas Instruments Incorporated and its subsidiaries (TI) reserve the right to make corrections, enhancements, improvements and other changes to its semiconductor products and services per JESD46, latest issue, and to discontinue any product or service per JESD48, latest issue. Buyers should obtain the latest relevant information before placing orders and should verify that such information is current and complete. All semiconductor products (also referred to herein as "components") are sold subject to TI's terms and conditions of sale supplied at the time of order acknowledgment.

TI warrants performance of its components to the specifications applicable at the time of sale, in accordance with the warranty in TI's terms and conditions of sale of semiconductor products. Testing and other quality control techniques are used to the extent TI deems necessary to support this warranty. Except where mandated by applicable law, testing of all parameters of each component is not necessarily performed.

TI assumes no liability for applications assistance or the design of Buyers' products. Buyers are responsible for their products and applications using TI components. To minimize the risks associated with Buyers' products and applications, Buyers should provide adequate design and operating safeguards.

TI does not warrant or represent that any license, either express or implied, is granted under any patent right, copyright, mask work right, or other intellectual property right relating to any combination, machine, or process in which TI components or services are used. Information published by TI regarding third-party products or services does not constitute a license to use such products or services or a warranty or endorsement thereof. Use of such information may require a license from a third party under the patents or other intellectual property of the third party, or a license from TI under the patents or other intellectual property of TI.

Reproduction of significant portions of TI information in TI data books or data sheets is permissible only if reproduction is without alteration and is accompanied by all associated warranties, conditions, limitations, and notices. TI is not responsible or liable for such altered documentation. Information of third parties may be subject to additional restrictions.

Resale of TI components or services with statements different from or beyond the parameters stated by TI for that component or service voids all express and any implied warranties for the associated TI component or service and is an unfair and deceptive business practice. TI is not responsible or liable for any such statements.

Buyer acknowledges and agrees that it is solely responsible for compliance with all legal, regulatory and safety-related requirements concerning its products, and any use of TI components in its applications, notwithstanding any applications-related information or support that may be provided by TI. Buyer represents and agrees that it has all the necessary expertise to create and implement safeguards which anticipate dangerous consequences of failures, monitor failures and their consequences, lessen the likelihood of failures that might cause harm and take appropriate remedial actions. Buyer will fully indemnify TI and its representatives against any damages arising out of the use of any TI components in safety-critical applications.

In some cases, TI components may be promoted specifically to facilitate safety-related applications. With such components, TI's goal is to help enable customers to design and create their own end-product solutions that meet applicable functional safety standards and requirements. Nonetheless, such components are subject to these terms.

No TI components are authorized for use in FDA Class III (or similar life-critical medical equipment) unless authorized officers of the parties have executed a special agreement specifically governing such use.

Only those TI components which TI has specifically designated as military grade or "enhanced plastic" are designed and intended for use in military/aerospace applications or environments. Buyer acknowledges and agrees that any military or aerospace use of TI components which have **not** been so designated is solely at the Buyer's risk, and that Buyer is solely responsible for compliance with all legal and regulatory requirements in connection with such use.

TI has specifically designated certain components as meeting ISO/TS16949 requirements, mainly for automotive use. In any case of use of non-designated products, TI will not be responsible for any failure to meet ISO/TS16949.

Products

Audio	www.ti.com/audio
Amplifiers	amplifier.ti.com
Data Converters	dataconverter.ti.com
DLP® Products	www.dlp.com
DSP	dsp.ti.com
Clocks and Timers	www.ti.com/clocks
Interface	interface.ti.com
Logic	logic.ti.com
Power Mgmt	power.ti.com
Microcontrollers	microcontroller.ti.com
RFID	www.ti-rfid.com
OMAP Applications Processors	www.ti.com/omap
Wireless Connectivity	www.ti.com/wirelessconnectivity

Applications

Automotive and Transportation	www.ti.com/automotive
Communications and Telecom	www.ti.com/communications
Computers and Peripherals	www.ti.com/computers
Consumer Electronics	www.ti.com/consumer-apps
Energy and Lighting	www.ti.com/energy
Industrial	www.ti.com/industrial
Medical	www.ti.com/medical
Security	www.ti.com/security
Space, Avionics and Defense	www.ti.com/space-avionics-defense
Video and Imaging	www.ti.com/video

TI E2E Community

e2e.ti.com