



TAOGLAS®



Datasheet

Part No:
CGGP.18.4.C.02

Description:
18mm Ceramic GPS/GLONASS/Galileo Patch Antenna, 1575-1610MHz

Features:
GPS/GLONASS/Galileo Operational
18mm*18mm*4mm
3dBi Peak Gain (on 70mm*70mm ground-plane)
Pin type
Automotive TS16949 Production and Quality Approved
RoHS & REACH compliant

1. Introduction	3
2. Specifications	4
3. Antenna Characteristics	5
4. Antenna 2D Radiation Pattern	8
5. Mechanical Drawing	9
6. Antenna Integration Guide	11
7. Evaluation Board (CGGPD.18.C)	16
8. PCB Footprint Recommendation	17
9. Packaging	18
<hr/>	
Changelog	19

Taoglas makes no warranties based on the accuracy or completeness of the contents of this document and reserves the right to make changes to specifications and product descriptions at any time without notice. Taoglas reserves all rights to this document and the information contained herein. Reproduction, use or disclosure to third parties without express permission is strictly prohibited.

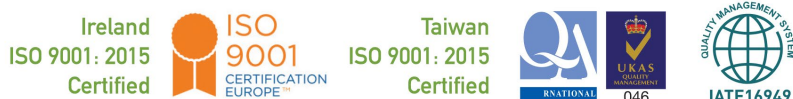

1. Introduction



This 18mm ceramic GPS/GLONASS/Galileo patch antenna, by means of a double resonance design, has unique wide-band operation over the whole operating bands of GPS and GLONASS systems from 1575MHz to 1610MHz. It is mounted via pin and double-sided adhesive.

This antenna has been tuned for a centre position on a 70mm*70mm ground-plane. It is manufactured and tested in a TS16949 first tier automotive approved facility. For further optimization to customer specific device environments where positioning is off centre or on different ground-plane sizes, custom tuned patch antennas can be supplied. For further information please contact your regional Taoglas customer support team.

2. Specifications

Electrical	
Range of Receiving Frequency	GPS: 1575.42±1.023MHz GLONASS: 1602±5MHz
Center Frequency	1592MHz ± 3MHz
Return Loss	<-4 dB
Efficiency	75%
Gain at Zenith	+3.0 dBi typ.
Impedance	50 ohms
Mechanical	
Ceramic Dimension	18mm x 18mm x 4mm
Pin Diameter	0.9mm
Pin Length	2.4mm
Weight	7g
Environmental	
Operation Temperature	-40°C to 85°C

* Antenna properties were measurement with the antenna mounted on 70*70mm Ground Plane

3. Antenna Characteristics

3.1 Test Setup

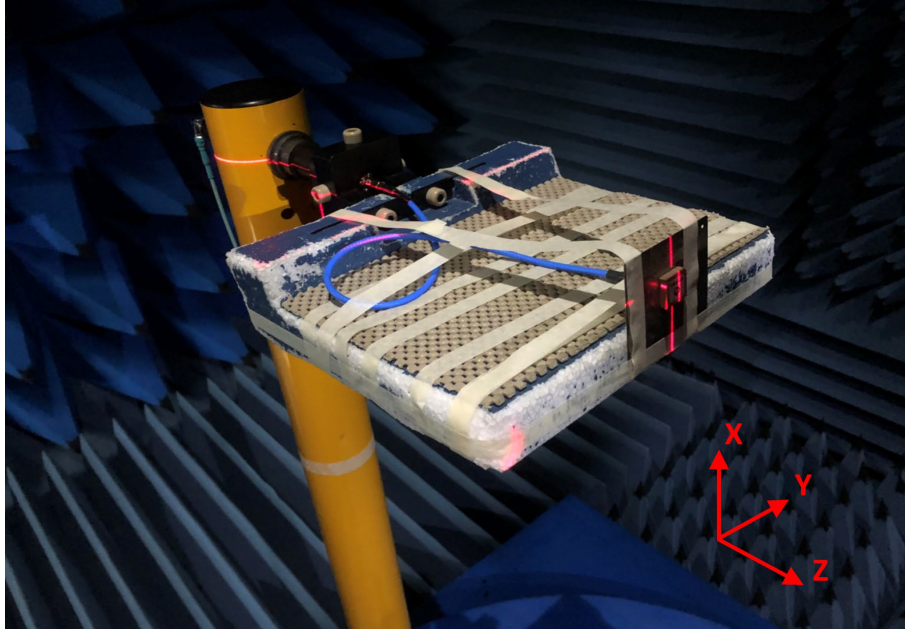

3.2 Return Loss

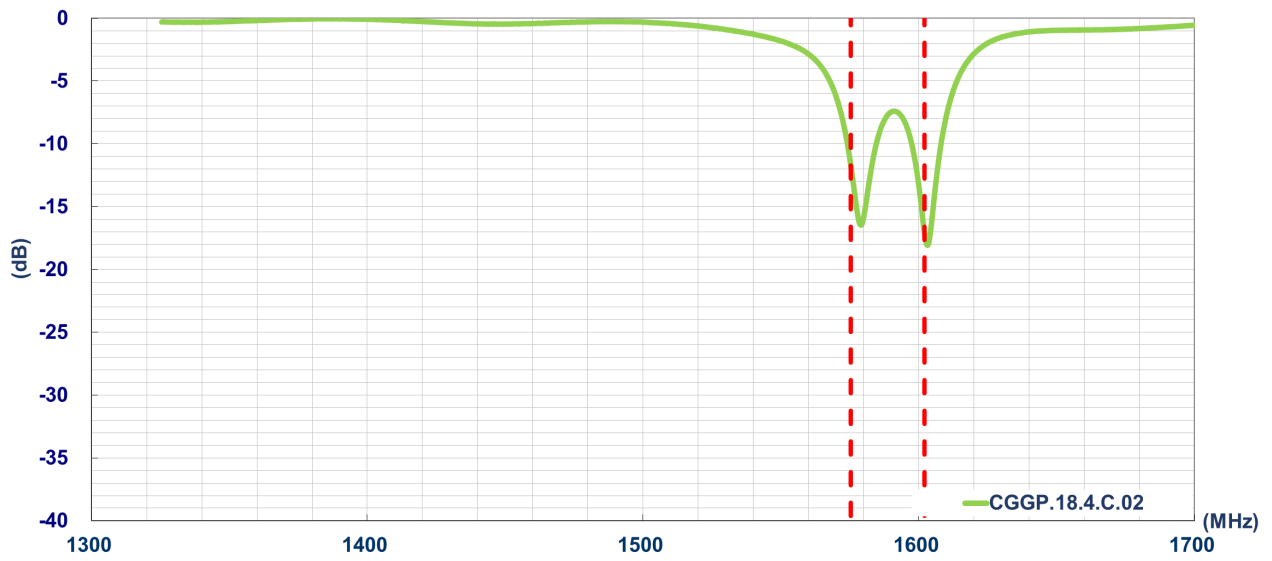

3.3 Efficiency

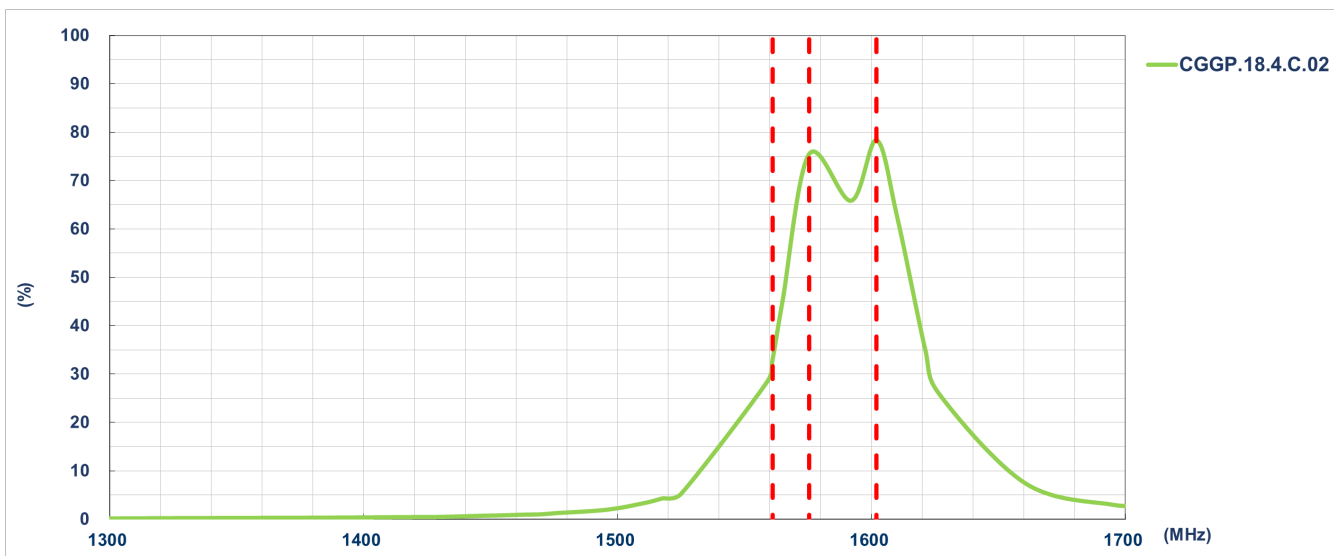

3.4 Average Gain

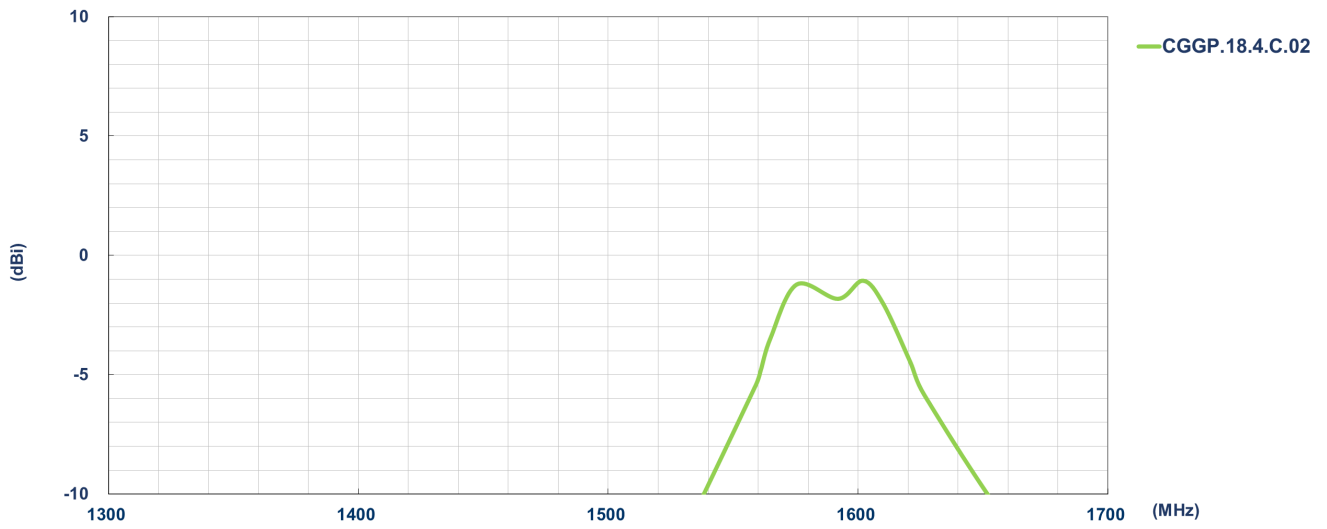

3.5 Peak Gain

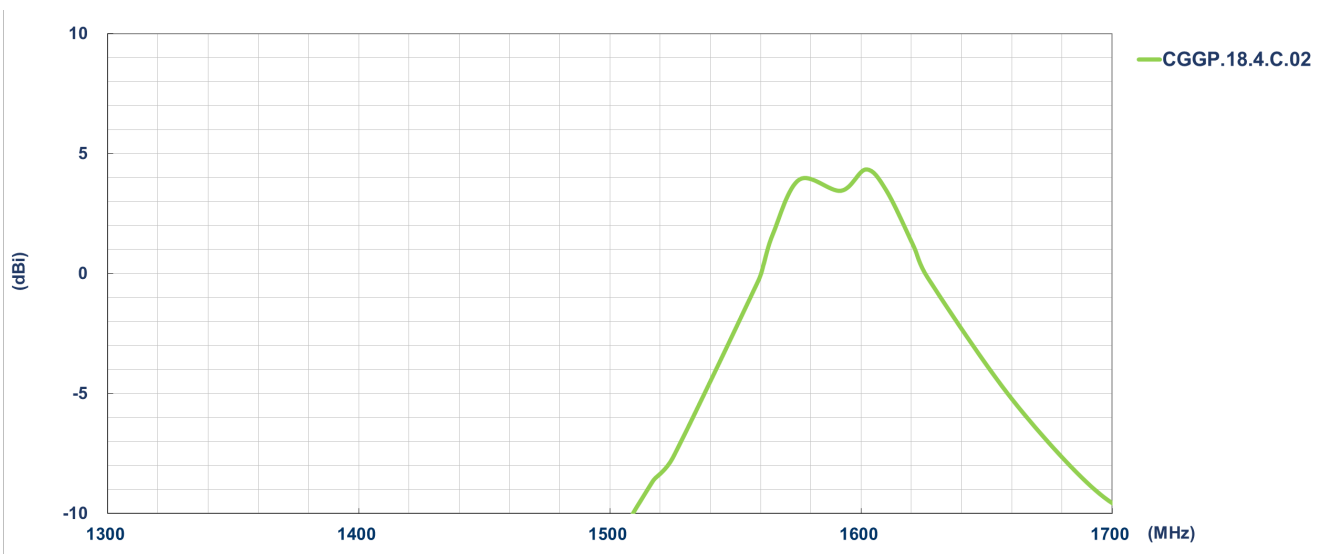

4. Antenna 2D Radiation Pattern

4.1 2D Radiation Pattern

XY Plane

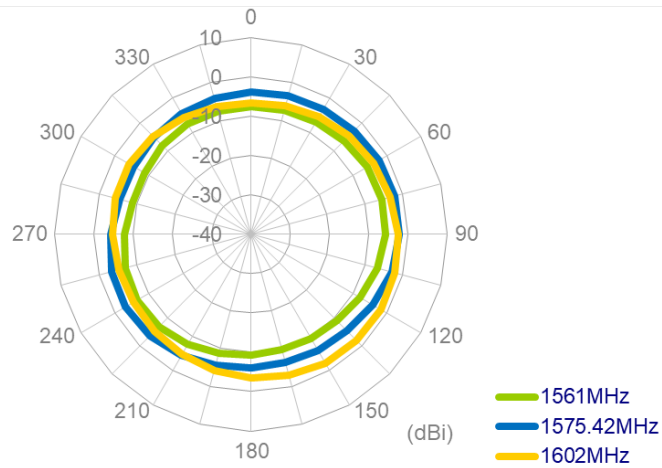

XZ Plane

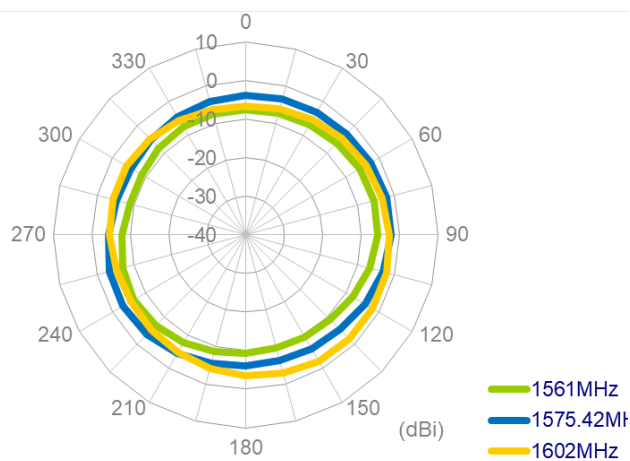

YZ Plane

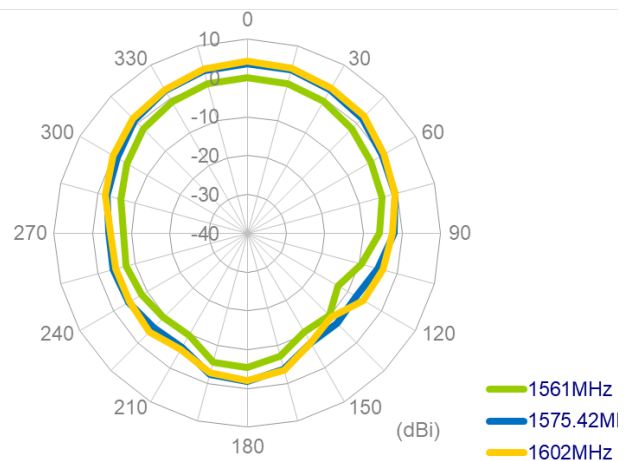

5. Mechanical Drawing (Unit: mm)

ISO NO.: EDW-11-8-474
STATE: Release

NOTES: 1. Double sided adhesive area

REV.	DESCRIPTION	ENG.	APPROVED	DATE
A	Initial Design	Kiwi	Jaonna	2011/09/13
B	Add CGGP.18.4.C.02 On Patch	Sandy	Jaonna	2012/10/30
C	Add P/N, Amend PIN Dimension.	Kim	Jaonna	2015/06/25
D	EC-21-08-010	Mickey	Buluto	2021/03/02
E	Replace the new LOGO <EDR-18-8-259>	Ruby	Aaron	2022/03/02

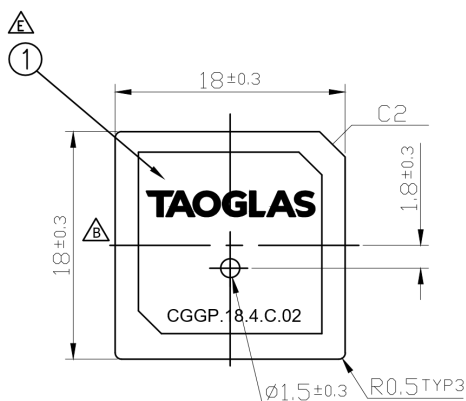

Top View

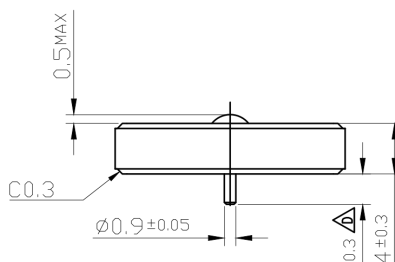

Side View

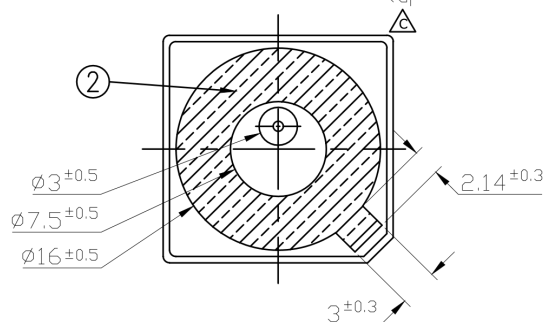

Bottom View

	Name	P/N	Material	Finish	QTY
1	CGGP.18 Patch 18x18x4	001513C070007A	Ceramic	Clear	1
2	Double sided Adhesive	001013C000007A	NITTO 5015	White Linter	1

APPROVED BY: Joanna	TW Design Centre This drawing and its inherent design concepts are property of Taoglas. Not to be copied or given to third parties without the written consent of Taoglas.
CHECK BY: Jimmy	
DRAWN BY: Kiwi	
DATE: 2011/09/13	
UNLESS OTHERWISE SPECIFIED TOLERANCES	XX±0.5 X±0.3 .XX±0.2 .XXX±0.1 .XXXX±0.05
90° IRD ANGLE PROJECTION	TITLE : 18x18x4 GPS/GLONASS Ceramic Patch PART NO. CGGP.18.4.C.02 UNIT: mm SCALE: 2:1 PAGES: 1/1 REV. E

Adhesive Thickness

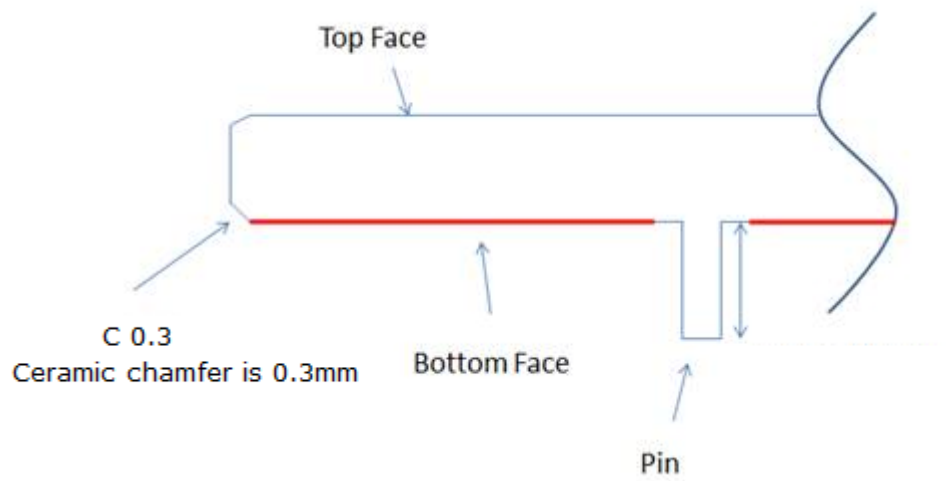

Red Line shows the adhesive without Liner – thickness 0.08~0.1mm

6. Antenna Integration Guide

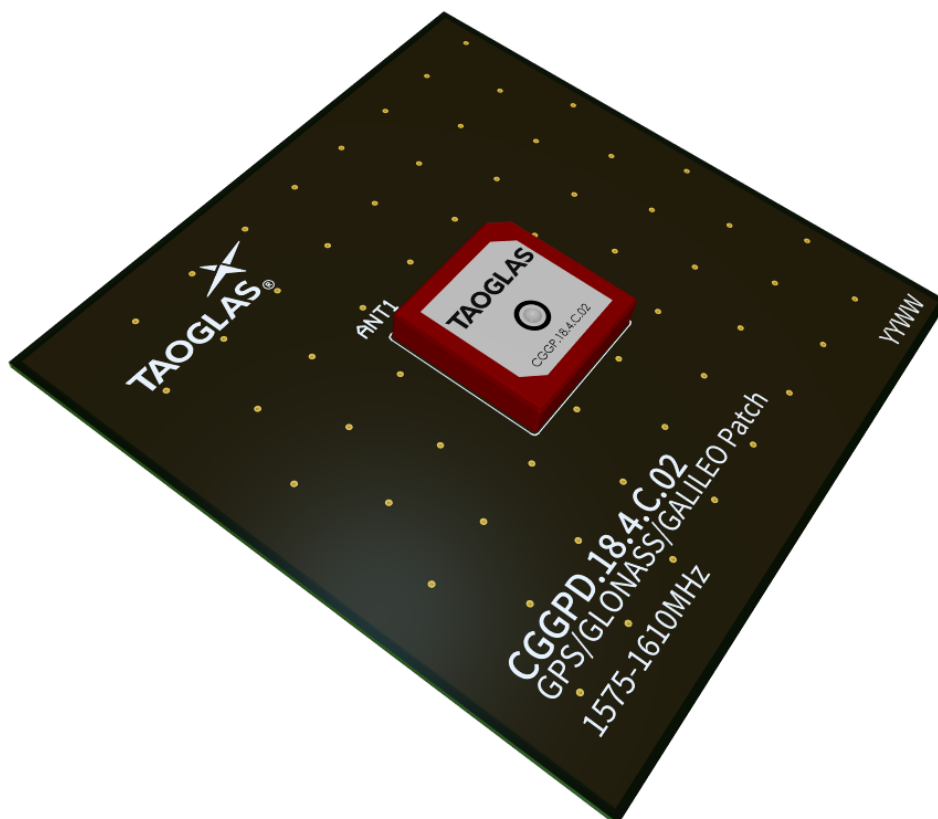

6.1 Schematic Symbol and Pin Definition

The circuit symbol for the antenna is shown below. The antenna has 1 pin as indicated below.

Pin	Description
1	RF Feed

ANT1

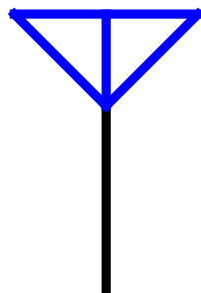

CGGP.18.4.C.02

6.2 Antenna Integration

The antenna should be placed at the center of the ground plane with a length and width of 70mm. Maintaining a square symmetric ground plane shape and symmetric environment around the antenna is critical to maintaining the excellent axial ratio and phase center performance shown in this datasheet.



Top Side w/ Solder Mask

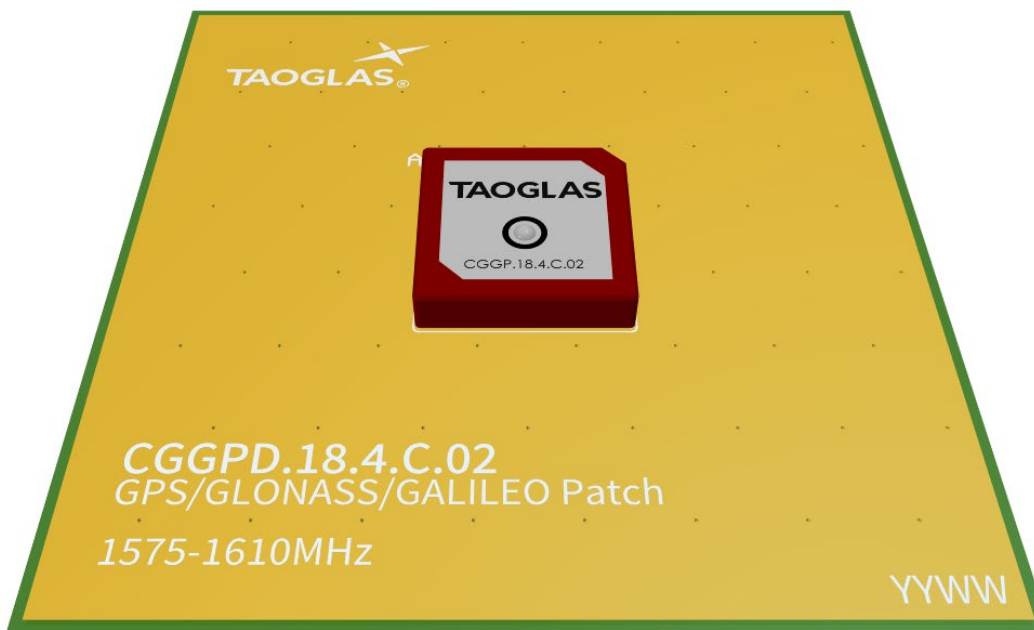

Top Side w/o Solder Mask

6.3 PCB Layout

The footprint and clearance on the PCB must comply with the antenna specification. The PCB layout shown in the diagram below demonstrates the antenna footprint.



Topside

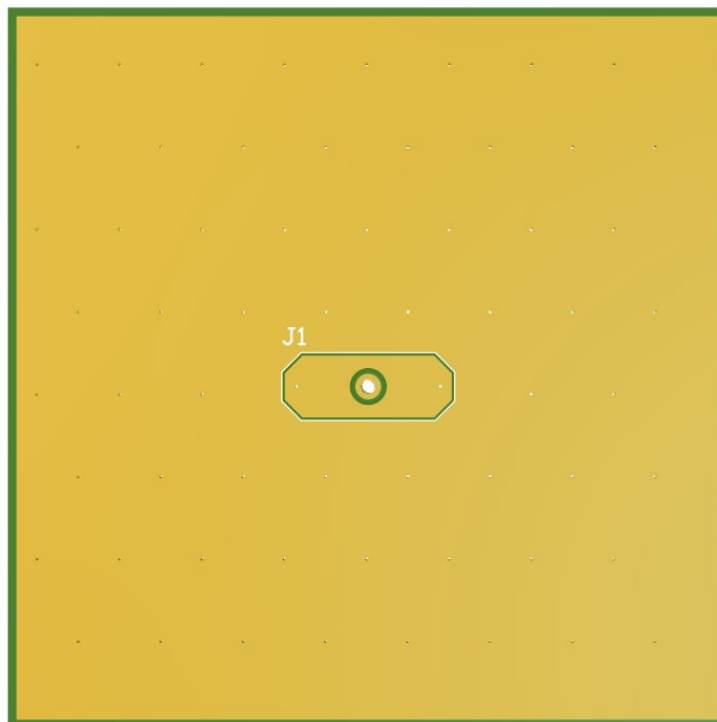

Bottom Side

6.5 Evaluation Board

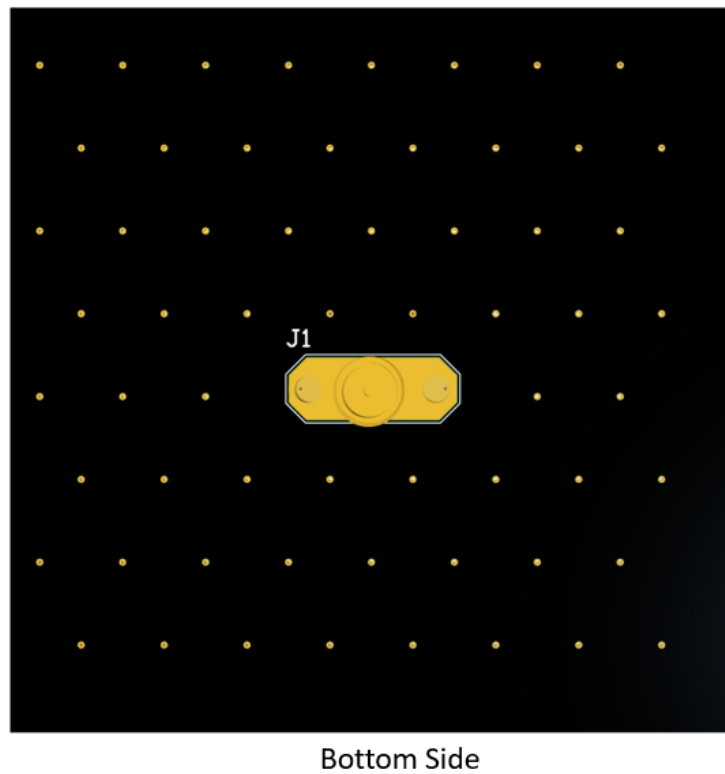
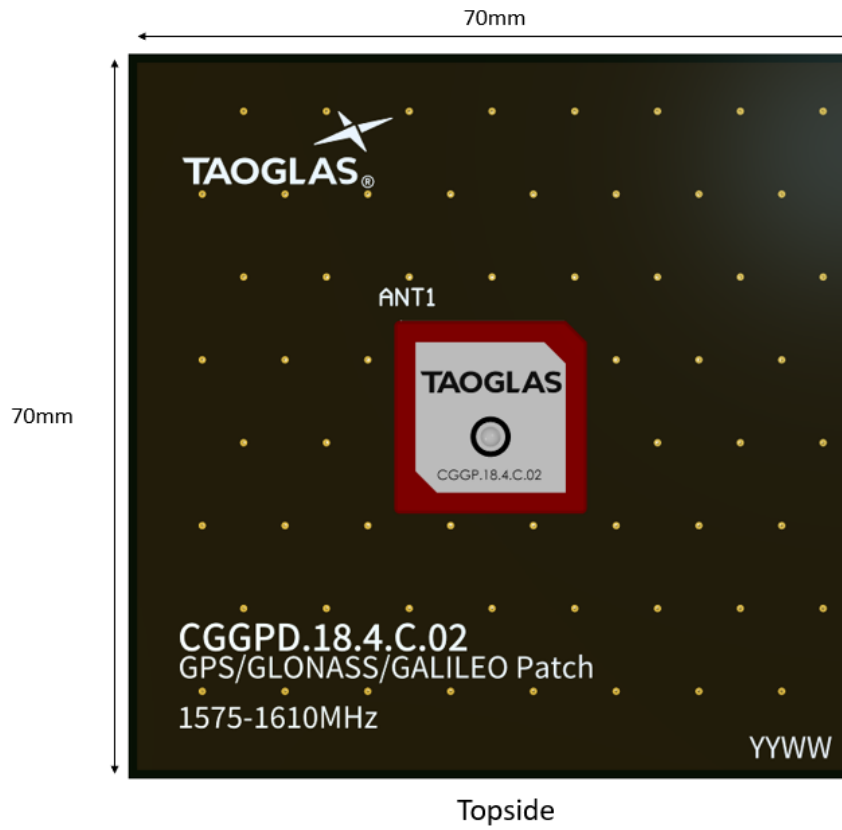

7. Evaluation Board (CGGPD.18.C) (Unit: mm)

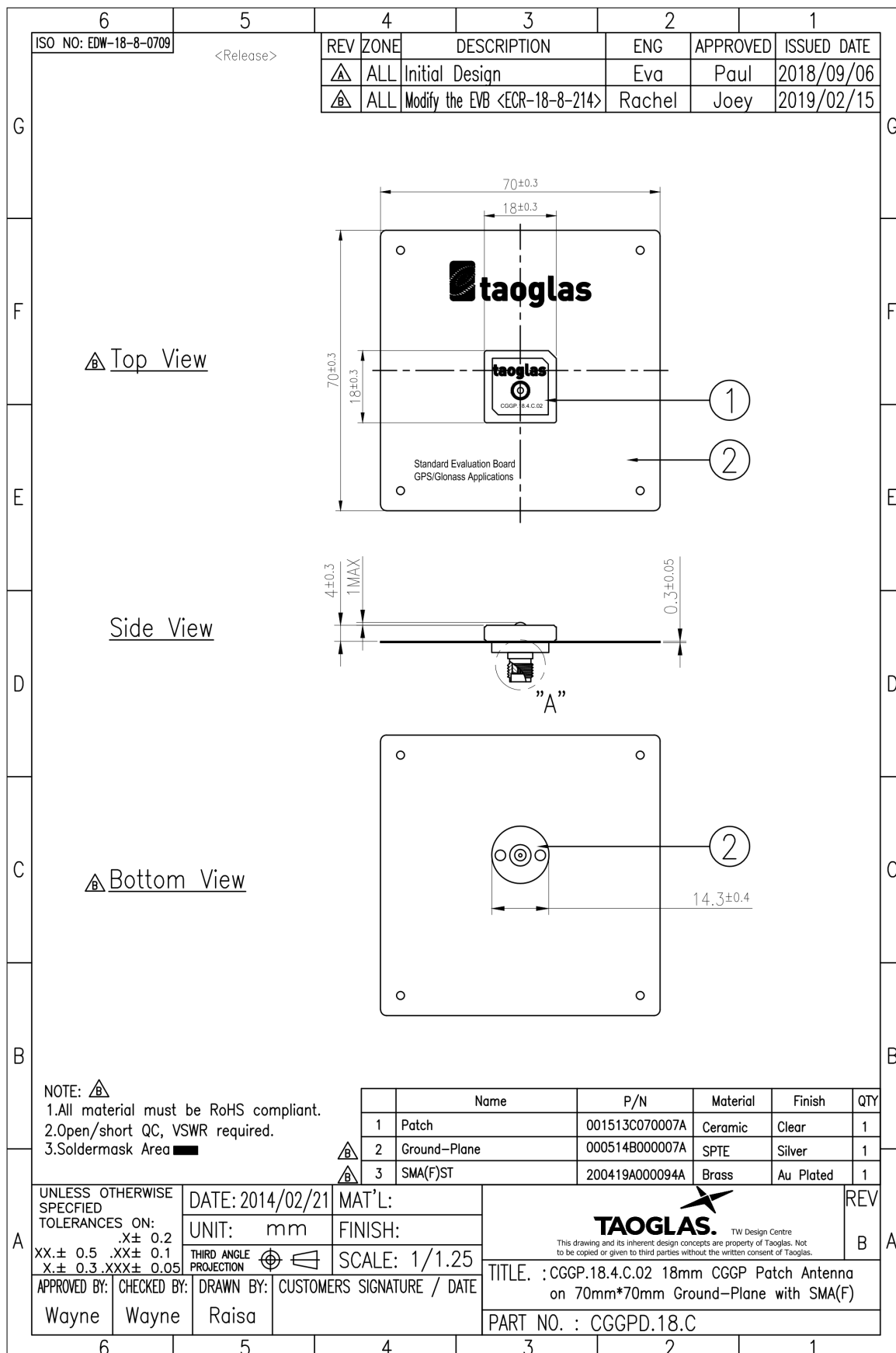

8. PCB Footprint Recommendation

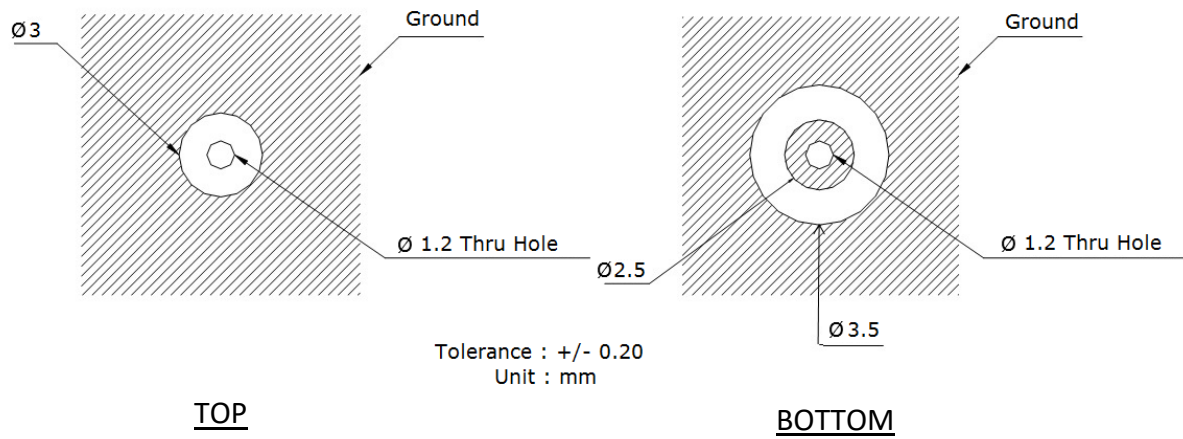

9. Packaging

25 pcs CGGBP.18.2.A.02 per tray
Tray Dimensions - 250*150*11mm

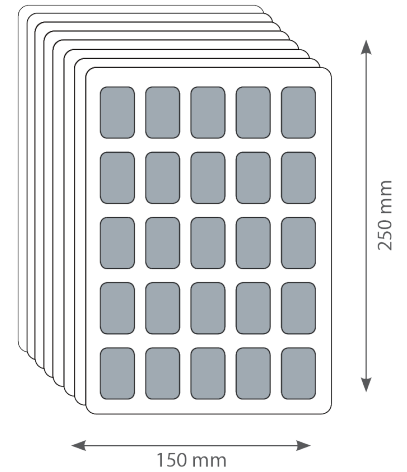

200 pcs CGGBP.18.4.A.02 per Inner Carton
Inner Carton Dimensions - 96*263*154mm

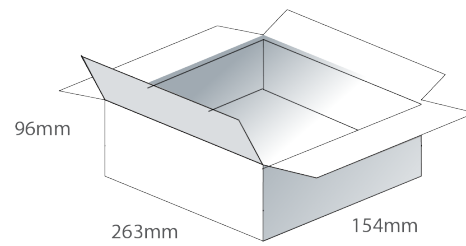

800 pcs CGGBP.18.4.A.08 per Carton
Carton Dimensions - 370*370*300mm

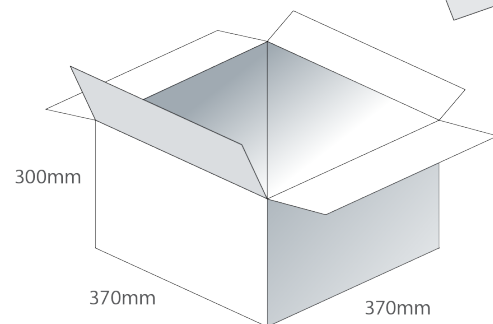

Changelog for the datasheet

SPE-11-8-098– CGGP.18.4.C.02

Revision: O (Current Version)

Date:	2024-05-17
Changes:	Updated pin length in spec table and removed moisture sensitivity level information from datasheet
Changes Made by:	Conor McGrath

Previous Revisions

Revision: N

Date:	2023-02-24
Changes:	Integration Guide Added
Changes Made by:	Cesar Sousa

Revision: I

Date:	2020-11-19
Changes:	Updated to new format Added Moisture Sensitivity Level 3 to Environmental Specifications
Changes Made by:	Dan Cantwell

Revision: M

Date:	2021-06-21
Changes:	Updated Pin Length to 2.4mm
Changes Made by:	Dan Cantwell

Revision: H

Date:	2018-11-06
Changes:	Added Plots
Changes Made by:	Technical Writer

Revision: L

Date:	2021-06-11
Changes:	Updated Mechanical Drawing
Changes Made by:	Gary West

Revision: G

Date:	2015-06-01
Changes:	Amended PCB footprint doc
Changes Made by:	Aine Doyle

Revision: K

Date:	2021-06-03
Changes:	Updated 2D & 3D Radiation Patterns
Changes Made by:	Gary West

Revision: F

Date:	2014-08-19
Changes:	Removed Circular Polarization from Spec
Changes Made by:	Aine Doyle

Revision: J

Date:	2021-03-26
Changes:	Updated Weight and Efficiency
Changes Made by:	Jack Conroy

Revision: E

Date:	2014-11-06
Changes:	Added EBV info
Changes Made by:	Aine Doyle

Previous Revisions

Revision: D	
Date:	2012-08-14
Changes:	
Changes Made by:	Technical Writer

Revision: C	
Date:	2012-02-27
Changes:	Added Packaging
Changes Made by:	Technical Writer

Revision: B	
Date:	2012-01-16
Changes:	
Changes Made by:	Technical Writer

Revision: A (Original First Release)	
Date:	2011-09-14
Notes:	
Author:	Technical Writer



www.taoglas.com

