



32A		40A		50A		65A		75A		85A	
 <p>See page 42 for more details</p>				 <p>See page 42 for more details</p>							
CGC-32A		CGC-40A		CGC-50A		CGC-65A		CGC-75A		CGC-85A	
CGC-32D		CGC-40D		CGC-50D		CGC-65D		CGC-75D		CGC-85D	
kW	A	kW	A	kW	A	kW	A	kW	A	kW	A
	50		60		80		100		110		135
7.5	32	11	40	15	55	18.5	65	22	75	25	85
15	32	18.5	40	22	50	30	65	37	75	45	85
18.5	28	22	32	30	43	33	60	37	64	45	75
18.5	20	22	23	30	28	33	35	37	42	45	45
hp	A	hp	A	hp	A	hp	A	hp	A	hp	A
	45		50		70		80		90		100
2		3		3		5		5		7.5	
5		5		7.5		10		15		15	
7.5		10		10		15		20		25	
10		10		15		20		25		30	
20		25		30		40		50		50	
20		25		30		40		50		50	
1		1		2		2		2		3	





2-pole
Front mount









4-pole
Front mount

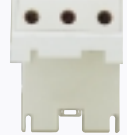

2-pole
Side mount

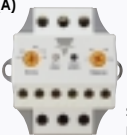
 <p>See page 54 for more details</p>				 <p>See page 56 for more details</p>							
CGC-32A/4		CGC-40A/4		CGC-50A/4		CGC-65A/4		CGC-75A/4		CGC-85A/4	
CGC-32D/4		CGC-40D/4		CGC-50D/4		CGC-65D/4		CGC-75D/4		CGC-85D/4	
50		60		80		100		110		135	

 <p>Setting ranges (A)</p> <table border="0"> <tr><td>4 - 6</td><td>12 - 18</td></tr> <tr><td>5 - 8</td><td>16 - 22</td></tr> <tr><td>6 - 9</td><td>18 - 26</td></tr> <tr><td>7 - 10</td><td>24 - 36</td></tr> <tr><td>9 - 13</td><td>28 - 40</td></tr> </table> <p>CGT-40</p>	4 - 6	12 - 18	5 - 8	16 - 22	6 - 9	18 - 26	7 - 10	24 - 36	9 - 13	28 - 40	 <p>Base for separate mount</p>	 <p>Setting ranges (A)</p> <table border="0"> <tr><td>7 - 10</td><td>28 - 40</td></tr> <tr><td>9 - 13</td><td>34 - 50</td></tr> <tr><td>12 - 18</td><td>45 - 65</td></tr> <tr><td>16 - 22</td><td>54 - 75</td></tr> <tr><td>18 - 26</td><td>63 - 85</td></tr> <tr><td>24 - 36</td><td></td></tr> </table> <p>CGT-85</p>	7 - 10	28 - 40	9 - 13	34 - 50	12 - 18	45 - 65	16 - 22	54 - 75	18 - 26	63 - 85	24 - 36		 <p>Base for separate mount</p>
4 - 6	12 - 18																								
5 - 8	16 - 22																								
6 - 9	18 - 26																								
7 - 10	24 - 36																								
9 - 13	28 - 40																								
7 - 10	28 - 40																								
9 - 13	34 - 50																								
12 - 18	45 - 65																								
16 - 22	54 - 75																								
18 - 26	63 - 85																								
24 - 36																									
CGT-40		CGT-85																							
CGTH-40/3		CGTH-85/3																							
CGTH-40		CGTH-85																							
CGT-40/L		CGT-85/L																							
 <p>Setting ranges (A)</p> <table border="0"> <tr><td>4 - 20</td></tr> <tr><td>8 - 40</td></tr> </table> <p>CGE40</p>	4 - 20	8 - 40	 <p>separate mount</p>	 <p>Setting ranges(A) : 16 ~ 80A</p> <p>Separate mount Wiring by screw</p> <p>CGE80</p>	 <p>Setting ranges(A) : 5 ~ 60A</p> <p>Separate mount Wiring by CT tunnel</p> <p>CGE60</p>																				
4 - 20																									
8 - 40																									

3-pole Contactors

50A

65A

75A

85A

Description

- Covering four rating classes in single size.
- 3-pole main contact
- Finger proof design
- DIN rail or screw mountable
- 2NO+2NC Auxiliary contacts built-in as standard
- Front/side mountable accessories available
- Direct mountable overload relays available

3-pole Contactors with AC coil

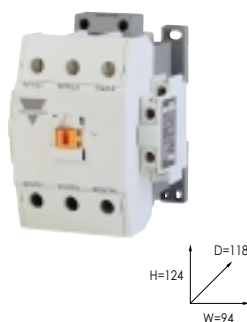

Frame size	AC3 ratings (IEC60947-4)				AC1 lth	Auxiliary contact (standard)	Type
	220 ~ 240V	380 ~ 440V	500 ~ 550V	690V			
50A	15kW 55A	22kW 50A	30kW 43A	30kW 28A	80A	2NO+2NC	CGC-50A
65A	18.5kW 65A	30kW 65A	33kW 60A	33kW 35A	100A	2NO+2NC	CGC-65A
75A	22kW 75A	37kW 75A	37kW 64A	37kW 42A	110A	2NO+2NC	CGC-75A
85A	25kW 85A	45kW 85A	45kW 75A	45kW 45A	135A	2NO+2NC	CGC-85A

Coil voltage, AC 50/60Hz

50Hz : 24, 42, 48, 100, 110, 220, 240, 380, 400, 415, 440, 500, 550V
60Hz : 24, 48, 110, 120, 208, 220, 240, 277, 380, 440, 480, 600V

3-pole Contactors with DC coil



Frame size	AC3 ratings (IEC60947-4)				AC1 lth	Auxiliary contact (standard)	Type
	220 ~ 240V	380 ~ 440V	500 ~ 550V	690V			
50A	15kW 55A	22kW 50A	30kW 43A	30kW 28A	80A	2NO+2NC	CGC-50D
65A	18.5kW 65A	30kW 65A	33kW 60A	33kW 35A	100A	2NO+2NC	CGC-65D
75A	22kW 75A	37kW 75A	37kW 64A	37kW 42A	110A	2NO+2NC	CGC-75D
85A	25kW 85A	45kW 85A	45kW 75A	45kW 45A	135A	2NO+2NC	CGC-85D

Coil voltage, DC

12, 20, 24, 48, 60, 80, 100, 110, 125, 200, 220, 250V

Mounting and Connection

Mounting	35mm DIN rail or holes for screw(M4) fixing		
Connection	Main	50A frame	Screw(M6) terminal Cable capacity : 2~22mm ²
		65/75/85A frame	Screw(M8) terminal Cable capacity : 2~38mm ²
	Auxiliary / Coil	Screw(M3.5) clamp terminal	

Certificate

CE, ULcUL, Lloyd, CCC(China)

Ordering information

Specify type and coil voltage

Options

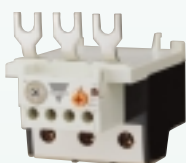

CGT-85
Thermal (Bimetallic) style
➤ page 66



CGE80
Electronic style
separate mount only
➤ page 80

For more information

Technical specification	➤ page 112~133
Drawings	➤ page 140
Circuit diagrams	➤ page 140
Reversing contactors	➤ page 92
Latching contactors	➤ page 97
Starters	➤ page 66
Overload relays	➤ page 65
UL rating	➤ page 13



AX-1
Aux. contact unit
2pole for side mount
➤ page 116



AX-2
Aux. contact unit
2pole for front mount
➤ page 116



AX-4
Aux. contact unit
2pole for front mount
➤ page 116



AR-85W
Mechanical interlock unit
➤ page 118



AT
Pneumatic timer
➤ page 121



AL-85
Mechanical latch unit
➤ page 119



AS
Surge absorber unit
➤ page 120

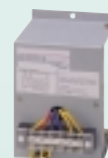

AR-800W
Delayed opening device
➤ page 121

Technical informations

DC application

Type	Poles in series	Rated current (DC2, DC4) DC motor load (L/R=15ms)				Rated current (DC1) Resistant load (L/R=1 ms)				Rated current (DC1) Coil load (L/R=100ms)			
		24V	48V	110V	220V	24V	48V	110V	220V	24V	48V	110V	220V
CGC-9A(D)	2	8	4	2.5	0.8	10	10	6	3	8	4	2	0.3
	3	8	6	4	2	10	10	8	8	8	6	3	0.8
CGC-12A(D)	2	12	6	4	1.2	12	12	10	7	12	6	3	0.5
	3	12	10	8	4	12	12	12	12	12	10	5	2
CGC-18A(D)	2	12	6	4	1.2	18	18	13	8	12	6	3	0.5
	3	12	10	8	4	18	18	18	18	12	10	5	2
CGC-22A(D)	2	20	15	8	2	20	20	15	10	20	12	3	1.2
	3	20	20	15	8	20	20	20	20	20	15	10	4
CGC-32A(D)	2	25	20	10	3	25	25	25	12	25	15	4	1.2
	3	25	25	20	10	25	25	25	22	25	25	12	4
CGC-40A(D)	2	35	20	10	3	35	35	25	12	35	15	4	1.2
	3	35	30	20	10	35	35	35	30	35	25	12	4
CGC-50A(D)	2	45	25	15	3.5	50	40	35	15				
	3	50	35	30	12	50	50	50	40				
CGC-65A(D)	2	45	25	15	3.5	50	40	35	15				
	3	50	35	30	12	65	65	65	50				
CGC-75A(D)	2	65	40	20	5	75	65	50	20				
	3	80	60	50	20	75	75	75	55				
CGC-85A(D)	2	65	40	20	5	80	65	50	20				
	3	80	60	50	20	80	80	80	60				
CGC-100	2	100	60	40	30	100	100	80	50				
	3	100	90	80	50	100	100	100	80				
CGC-125	2	120	60	40	30	120	100	80	50				
	3	120	90	80	50	120	120	100	80				
CGC-150	2	150	100	80	60	150	120	100	100				
	3	150	130	120	80	150	150	150	150				
CGC-180	2	180	150	120	80	180	180	150	150				
	3	180	180	150	100	180	180	180	180				
CGC-220	2	220	150	120	80	220	180	150	150				
	3	220	220	150	100	220	220	220	220				
CGC-300	2	300	200	150	90	300	240	200	200				
	3	300	280	200	150	300	300	300	300				
CGC-400	2	400	200	150	90	400	240	200	200				
	3	400	280	200	150	400	400	400	300				
CGC-600	2	630	630	630	630	630	630	630	630				
	3	630	630	630	630	630	630	630	630				
CGC-800	2	800	630	630	630	800	800	630	630				
	3	800	630	630	630	800	800	800	800				

2 poles in series

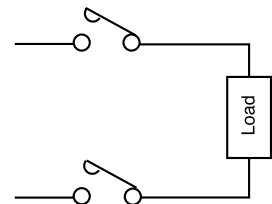

3 poles in series

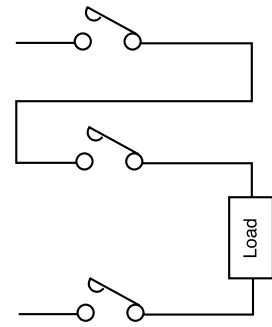

Technical informations

Selection guide for lighting circuit switching

Incandescent

Maximum quantity of lamps per contactor

Type	Consumption	100V								200V							
		100W	150W	200W	250W	300W	500W	1000W	1500W	100W	150W	200W	250W	300W	500W	1000W	1500W
CGC-9A(D)		11	7	5	4	3	2	1	-	22	14	11	8	7	4	2	1
CGC-12A(D)		13	8	6	5	4	2	1	-	26	17	13	10	8	5	2	1
CGC-18A(D)		18	12	9	7	6	3	1	1	36	24	18	14	12	7	3	2
CGC-22A(D)		19	12	9	7	6	3	1	1	38	25	19	15	12	7	3	2
CGC-32A(D)		26	17	13	10	8	5	2	1	52	34	26	20	17	10	5	3
CGC-40A(D)		35	23	17	14	11	7	3	2	70	46	35	28	23	14	7	4
CGC-50A(D)		50	33	25	20	15	10	5	3	100	66	50	40	33	20	10	6
CGC-65A(D)		65	42	32	26	19	13	6	4	130	85	65	52	42	26	13	8

Fluorescent

Maximum quantity of rapid-start fluorescents per contactor

Type	Consumption	100V							200V							
		40W		60W	80W	110W		220W	40W		60W	80W	110W		220W	
	N° Fluorescent.	1	2	1	1	1	2	1	1	2	1	1	1	2	1	1
	(A)	0.95 (1.2)	0.96 (1.1)	0.92	1.17	1.55	2.5	2.7	0.29 (0.6)	0.48 (0.55)	0.46	0.58	0.78	1.3	1.36	2.5
CGC-9A(D)		18 (9)	11 (10)	12	9	7	4	4	37 (18)	22 (20)	23	19	14	8	8	4
CGC-12A(D)		22 (10)	13 (11)	14	11	8	5	4	44 (21)	27 (23)	28	22	16	10	9	5
CGC-18A(D)		30 (15)	18 (16)	19	15	11	7	6	62 (30)	37 (32)	39	31	23	13	13	7
CGC-22A(D)		32 (15)	19 (17)	20	16	12	7	7	65 (31)	39 (34)	41	32	24	14	14	7
CGC-32A(D)		44 (21)	27 (23)	28	22	16	10	9	89 (43)	54 (47)	56	44	33	20	19	10
CGC-40A(D)		59 (29)	36 (31)	38	29	22	14	13	120 (58)	72 (63)	76	60	44	26	25	14
CGC-50A(D)		84 (41)	52 (45)	54	42	32	20	18	172 (83)	104 (90)	108	86	64	38	37	20
CGC-65A(D)		110 (54)	67 (59)	70	55	41	26	24	224 (108)	135 (118)	141	112	83	50	48	26

Note) 1. In 1 lamps, () is the number of the lamps with low power factor.
2. In 2 lamps, () is the number of the flickerness type lamps.

Mercury lamp

Maximum quantity of mercury lamps per contactor

Type	Consumption	Low power factor type-High power factor type															
		40W	100W	200W	250W	300W	400W	700W	1000W	40W	100W	200W	250W	300W	400W	700W	1000W
	(A)	1.25	2.6	4.6	5.1	6.0	8.0	14.5	21	0.53	1.0	1.9	2.1	2.5	3.3	5.9	8.5
	0.55	1.4	2.6	3.0	3.7	4.9	8.5	12	-	0.65	1.2	1.5	1.8	2.3	4.1	5.8	
CGC-9A(D)		8/20	4/7	2/4	2/3	1/2	1/1	-/-	-/-	20/-	11/16	5/9	5/7	4/6	3/4	1/2	1/1
CGC-12A(D)		10/23	5/9	2/5	2/4	2/3	1/1	-/1	-/1	24/-	13/20	6/10	6/8	5/7	3/5	2/3	1/2
CGC-18A(D)		14/32	6/12	3/6	3/6	3/4	2/3	1/2	-/1	33/-	18/27	9/15	8/12	7/10	5/7	3/3	2/3
CGC-22A(D)		15/34	7/13	4/7	3/6	3/5	2/3	1/2	-/1	35/-	19/29	10/15	9/12	7/10	5/8	3/4	2/3
CGC-32A(D)		20/47	10/18	5/10	5/8	4/7	3/5	1/3	1/2	49/-	26/40	13/21	12/17	10/14	7/11	4/6	3/4
CGC-40A(D)		28/63	13/25	7/13	6/11	5/9	4/7	2/4	1/2	66/-	35/53	18/29	16/23	14/19	10/15	5/8	4/6
CGC-50A(D)		40/90	19/35	10/19	9/16	8/13	6/10	3/5	2/4	94/-	50/76	26/41	23/33	20/27	15/21	8/12	6/8
CGC-65A(D)		52/118	25/46	14/25	12/21	10/17	8/13	4/7	3/5	122/-	65/100	34/54	30/43	26/36	19/28	11/15	7/11

Technical informations

Short circuit coordination

Contactors with protection fuses

Type	AC1(A)	690V AC3 Ie(A)	Short-circuit test	
			Fuse available fault current 100,000A	Ue / "r"
CGC-9A	20	5	gL/gG 25A	690V/1kA
CGC-12A	20	9	gL/gG 32A	690V/1kA
CGC-18A	25	9	gL/gG 35A	690V/3kA
CGC-22A	32	18	gL/gG 50A	690V/3kA
CGC-32A	50	20	gL/gG 63A	690V/3kA
CGC-40A	60	23	gL/gG 80A	690V/3kA
CGC-50A	80	28	gL/gG 100A	690V/3kA
CGC-65A	100	35	gL/gG 100A	690V/3kA
CGC-75A	110	42	gL/gG 100A	690V/3kA
CGC-85A	135	45	gL/gG 200A	690V/3kA
CGC-100	150	65	gL/gG 150A	690V/5kA
CGC-125	150	70	gL/gG 160A	690V/5kA
CGC-150	200	100	gL/gG 200A	690V/5kA
CGC-180	230	120	gL/gG 225A	690V/5kA
CGC-220	260	150	gL/gG 250A	690V/10kA
CGC-300	350	220	gL/gG 355A	690V/10kA
CGC-400	420	300	gL/gG 400A	690V/10kA
CGC-600	660	420	gL/gG 630A	690V/18kA
CGC-800	800	630	gL/gG 800A	690V/18kA

Note) Tables are based on a combination of tests on a previous range and technical comparison.

Technical informations

Electrical lifetime : CGC-9A to 85A

3 phase /
AC 220~240V

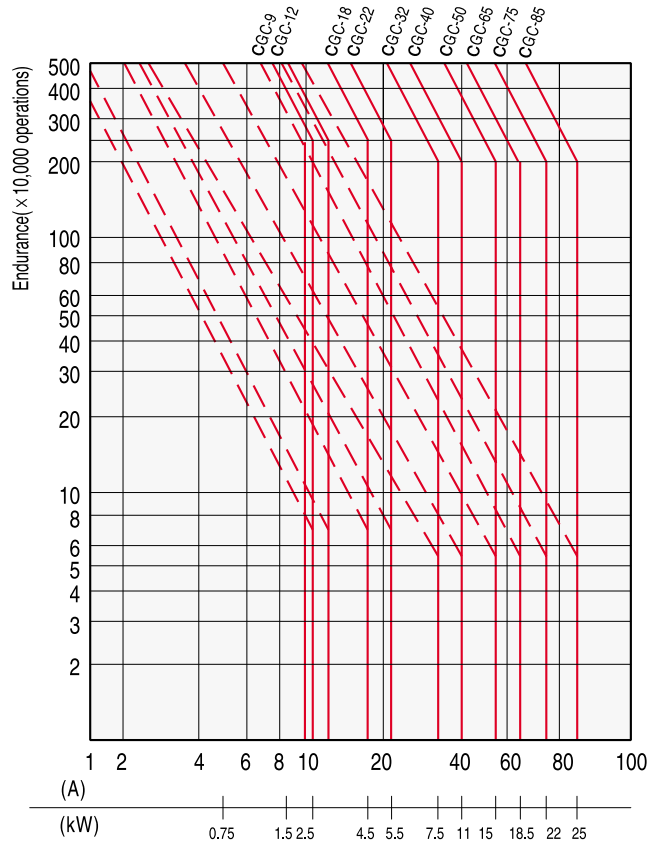

3 phase /
AC 380~440V

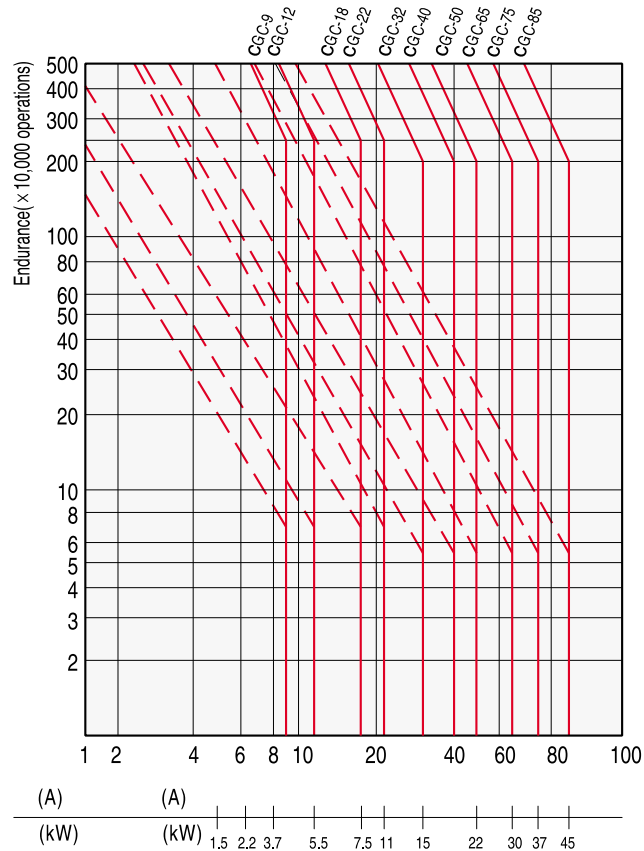

Technical informations

Ratings of Auxiliary contacts

Type	Rated current(A)																AC1 (lth) A
	AC13				DC 13				AC 12				DC 13				
	110V	120V	440V	550V	24V	48V	110V	220V	110V	220V	440V	550V	24V	48V	110V	220V	
CGC-9A(D)~22A(D)	6	3	1.5	1.2	3	1.5	0.55	0.27	10	8	5	5	5	3	2.5	1	16
CGC-32A(D)~85A(D)	6	3	1.5	1.2	3	1.5	0.55	0.27	10	8	5	5	5	3	2.5	1	16
CGC-100~800	6	5	3	3	6	3	1.2	0.2	10	10	5	5	5	3	1.5	0.25	16

Coil characteristics

Operating limits

When the operating coil is in the energized state an operating tolerance of between 85~110% of the coil's rated voltage is permitted, at temperatures up to 40°C at standard operating frequency. Operation out with the above may cause deterioration to electrical insulation and mechanical operation.

Selections of coil

In CGC-9A~85A contactors, 50Hz coil and 60Hz coil are separated.

But in CGC-100~800 contactors, the coils are AC/DC common use. (under DC 220V)

Characteristics of AC coil

AC 220V

Type	Coil consumption (VA)		Thermal dissipation (W)	Operational voltage(V)		Coil current (mA)	Operational time (ms)	
	Inrush	Holding		Pick-up	Drop-out		Closing	Opening
CGC-9A(/4)~22A(/4)	95	9	2	141~156(142~157)*	105~125(112~132)*	41(36)	10~17	6~9
CGC-32A(/4), 40A(/4)	95	9	2	150~165(151~166)*	110~130(117~137)*	41(36)	11~19	6~10
CGC-50A(/4)~85A(/4)	220	17	5	145~160(146~161)*	100~120(107~127)*	77(68)	16~25	8~15
CGC-100, 125	298	12.3	4.4	77	48	56	30~34	63~67
CGC-150	298	12.3	4.4	77	48	56	37~41	47~52
CGC-180, 200	380	11.6	4.7	77	48	53	45	45
CGC-100(/4)~220(/4)	380	11.6	4.7	77	48	53	45	45
CGC-300(/4), 400(/4)	571	14	5	77	48	64	45~50	48~52
CGC-600(/4), 800(/4)	1000	29	7.8	150	91	132	66~69	55

Note) 1. Average values. 2. () * values for 50Hz.

AC 110V

Type	Coil consumption (VA)		Thermal dissipation (W)	Operational voltage(V)		Coil current (mA)	Operational time (ms)	
	Inrush	Holding		Pick-up	Drop-out		Closing	Opening
CGC-9A(/4)~22A(/4)	95	9	2	75~85(74~84)*	55~65(54~64)*	73(73)*	11~18	6~9
CGC-32A(/4), 40A(/4)	95	9	2	75~85(74~84)*	55~65(54~64)*	73(73)*	13~20	6~9
CGC-50A(/4)~85A(/4)	220	17	5.5	68~78(67~77)*	40~50(39~49)*	154(154)*	16~25	9~16
CGC-100, 125	162	9.8	3.1	77	48	89	46~50	49~53
CGC-150	162	12.2	3	77	48	111	56~60	44~48
CGC-180, 200	220	9.1	3.4	77	48	83	60	41
CGC-100(/4)~220(/4)	220	9.1	3.4	77	48	83	60	41
CGC-300(/4), 400(/4)	393	14	4.4	77	48	128	64~68	43~47
CGC-600(/4), 800(/4)	1000	17	6.3	77	48	155	66~70	45~49

Note) 1. Average values. 2. () * values for 50Hz.

Characteristics of DC coil

DC 110V

Type	Coil consumption (VA)		Thermal contact (W)	Operational voltage(V)		Coil current (mA)	Operational time (ms)	
	Inrush	Holding		Pick-up	Drop-out		Closing	Opening
CGC-9D(/4)~22D(/4)	9	9	50	60~75	15~35	82	45~55	8~15
CGC-32D(/4), 40D(/4)	9	9	50	60~75	15~35	82	45~55	8~15
CGC-50D(/4)~85D(/4)	220	5	-	65~80	15~35	46	20~30	13~20

Performance of Contactors



Type	Rated voltage (V)	Rated current (A)	Short circuit max. current	Breaking capacity	Cycles per hour at AC3	Endurance (×10,000 operations)		Performance Indicate
						Mechanical	Electrical	
CGC-9A	220	11	132	110	1800	2500	250	AC3 · 1 · 0-0
	440	9	108	90				
CGC-12A	220	13	156	130	1800	2500	250	AC3 · 1 · 0-0
	440	12	144	120				
CGC-18A	220	18	216	180	1800	2500	250	AC3 · 1 · 0-0
	440	18	216	180				
CGC-22A	220	22	264	220	1800	2500	250	AC3 · 1 · 0-0
	440	22	264	220				
CGC-32A	220	32	385	320	1800	1500	200	AC3 · 1 · 0-0
	440	32	385	320				
CGC-40A	220	40	480	400	1800	1500	200	AC3 · 1 · 0-0
	440	40	480	400				
CGC-50A	220	55	660	550	1200	1000	200	AC3 · 1 · 0-0
	440	50	600	500				
CGC-65A	220	65	780	650	1200	1000	200	AC3 · 1 · 0-0
	440	65	780	650				
CGC-75A	220	75	900	750	1200	1000	200	AC3 · 1 · 0-0
	440	75	900	750				
CGC-85A	220	80	960	800	1200	1000	200	AC3 · 1 · 0-0
	440	80	960	800				
CGC-100	220	105	1050	1050	1200	500	100	AC3 · 1 · 1-0
	440	105	1050	1050				
CGC-125	220	125	1250	1250	1200	500	100	AC3 · 1 · 1-0
	440	120	1200	1200				
CGC-150	440	150	1500	1500	1200	500	100	AC3 · 1 · 1-0
	440	150	1500	1500				
CGC-180	220	180	1800	1800	1200	500	100	AC3 · 1 · 1-0
	440	180	1800	1800				
CGC-220	220	220	2200	2200	1200	500	100	ACC3 · 1 · 1-0
	440	220	2200	2200				
CGC-300	220	300	3000	3000	1200	500	100	AC3 · 1 · 1-0
	440	300	3000	3000				
CGC-400	220	400	4000	4000	1200	500	50	AC3 · 1 · 1-1
	440	400	4000	4000				
CGC-600	220	630	6300	6300	1200	500	50	ACC3 · 1 · 1-1
	440	630	6300	6300				
CGC-800	220	800	8000	8000	1200	500	50	AC3 · 1 · 1-1
	440	800	8000	8000				

Test duty of the electrical endurance (AC3)

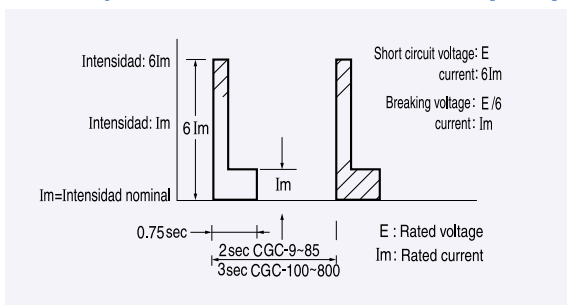

Test duty of the electrical endurance (AC4)

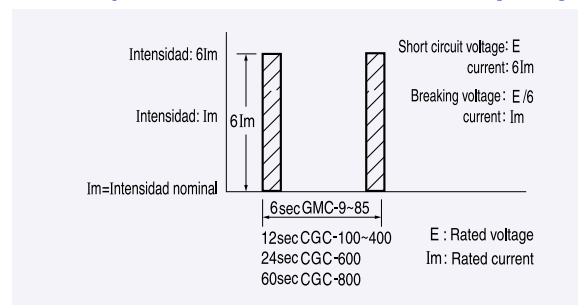

Technical informations

Cabling and tightening torque

3-pole Contactors

Type	Cable section		Screw size		Torque(Nm)		
	AWG /MCM	ISOmm ²		Contactor terminal	Coil terminal	Principal main	Aux.
		MIN	MAX				
CGC-9A	10 AWG	1,5	4	M4	M3.5	2,3	2,3
CGC-12A	10 AWG	1,5	4	M4	M3.5	2,3	2,3
CGC-18A	10 AWG	1,5	6	M4	M3.5	4	2,3
CGC-22A	8 AWG	2,5	10	M4	M3.5	4	2,3
CGC-32A	6 AWG	4	16	M5	M3.5	4	2,3
CGC-40A	6 AWG	4	16	M5	M3.5	4	2,3
CGC-50A	4 AWG	6	25	M6	M3.5	5	2,3
CGC-65A	2 AWG	10	35	M8	M3.5	5	2,3
CGC-75A	2 AWG	10	35	M8	M3.5	5	2,3
CGC-85A	0 AWG	10	50	M8	M3.5	5	2,3
CGC-100	00 AWG	25	70	M8	M4	9	2,3
CGC-125	00 AWG	25	70	M8	M4	9	2,3
CGC-150	0000 AWG	35	95	M8	M4	9	2,3
CGC-180	250 MCM	50	120	M10	M4	15	2,3
CGC-220	300 MCM	70	150	M10	M4	15	2,3
CGC-300	500 MCM	95	240	M12	M4	23	2,3
CGC-400	N°2 30×5	150		M12	M4	23	2,3
CGC-600	N°2 50×5	240		M16	M4	57	2,3
CGC-800	N°2 60×5	240		M16	M4	57	2,3

4-pole Contactors

Type	Cable section		Screw size		Torque(Nm)	
	AWG/MCM	ISOmm ²	Contactor terminal	Coil terminal	Principal main	Aux.
CGC-9A/4	10 AWG	4	M3.5	M3.5	2,3	2,3
CGC-12A/4	10 AWG	4	M3.5	M3.5	2,3	2,3
CGC-18A/4	8 AWG	6	M4	M3.5	4	2,3
CGC-22A/4	8 AWG	10	M4	M3.5	4	2,3
CGC-32A/4	6 AWG	16	M5	M3.5	4	2,3
CGC-40A/4	6 AWG	16	M5	M3.5	4	2,3
CGC-50A/4	4 AWG	25	M6	M3.5	5	2,3
CGC-65A/4	2 AWG	35	M8	M3.5	5	2,3
CGC-75A/4	2 AWG	35	M8	M3.5	5	2,3
CGC-85A/4	0 AWG	50	M8	M3.5	5	2,3
CGC-100/4	00 AWG	70	M8	M4	9	2,3
CGC-125/4	00 AWG	70	M8	M4	9	2,3
CGC-150/4	0000 AWG	95	M8	M4	9	2,3
CGC-180/4	250 MCM	120	M10	M4	15	2,3
CGC-220/4	300 MCM	150	M10	M4	15	2,3
CGC-300/4	500 MCM	240	M12	M4	23	2,3
CGC-400/4	N°2 30×5	150	M12	M4	23	2,3
CGC-600/4	N°2 50×5	240	M16	M4	57	2,3
CGC-800/4	N°2 60×5	240	M16	M4	57	2,3

Thermal overload relays

Type	Setting range	Cable selection		Torque (Nm)	Tornillo screw size	
		AWG /MCM	ISOmm ²			
CGT(H)-22	0.1~0.16	18AWG	1,5	2,3	M4	
	0.16~0.25	18AWG	1,5	2,3	M4	
	0.25~0.4	18AWG	1,5	2,3	M4	
	0.4~0.63	18AWG	1,5	2,3	M4	
	0.63~1	18AWG	1,5	2,3	M4	
	1~1.6	18AWG	1,5	2,3	M4	
	1.6~2.5	18AWG	1,5	2,3	M4	
	2.5~4	18AWG	1,5	2,3	M4	
	4~6	18AWG	1,5	2,3	M4	
	5~8	16AWG	1,5	2,3	M4	
	6~9	16AWG	1,5	2,3	M4	
	7~10	16AWG	1,5	2,3	M4	
	9~13	14AWG	1,5-2,5	2,3	M4	
	12~18	12AWG	2,5	2,3	M4	
	16~22	10AWG	2,5-4,0	2,3	M4	
	CGT(H)-40	4~6	18AWG	1,5	4	M5
5~8		16AWG	1,5	4	M5	
6~9		16AWG	1,5	4	M5	
7~10		16AWG	1,5	4	M5	
9~13		14AWG	1,5-2,5	4	M5	
12~18		12AWG	2,5	4	M5	
16~22		10AWG	2,5-4,0	4	M5	
18~26		10AWG	2,5-6,0	4	M5	
24~36		10AWG	4,0-10	4	M5	
28~40		10AWG	6,0-10	4	M5	
7~10		16AWG	1,5	5,1	M6	
9~13		14AWG	1,5-2,5	5,1	M6	
12~18		12AWG	2,5	5,1	M6	
16~22		10AWG	2,5-4,0	5,1	M6	
18~26		10AWG	2,5-6,6	5,1	M6	
24~36		10AWG	4,0-10	5,1	M6	
CGT(H)-85	28~40	10AWG	6,0-10	5,1	M6	
	34~50	6AWG	10-16	5,1	M6	
	45~65	4AWG	10-25	5,1	M8	
	54~75	4AWG	16-25	5,1	M8	
	63~85	3AWG	16-35	5,1	M8	
	34~50	6AWG	10-16	9	M8	
	39~57	6AWG	10-16	9	M8	
	43~65	4AWG	10-25	9	M8	
	CGT(H)-125	54~80	4AWG	16-25	9	M8
		65~100	2AWG	25-35	9	M8
		85~125	1AWG	35-50	9	M8
		34~50	6AWG	10-16	9	M8
	CGT(H)-150	39~57	6AWG	10-16	9	M8
		43~65	4AWG	10-25	9	M8
		54~80	4AWG	16-25	9	M8
		65~100	2AWG	25-35	9	M8
85~125		1AWG	35-50	9	M8	
100~150		00AWG	35-70	9	M8	
65~100		2AWG	25-35	15	M10	
85~125		1AWG	35-50	15	M10	
CGT(H)-220	100~160	00AWG	35-70	15	M10	
	120~180	000AWG	50-95	15	M10	
	160~240	250AWG	70-120	15	M10	
	85~125	1AWG	35-50	23	M12	
CGT(H)-400	100~160	00AWG	35-70	23	M12	
	120~180	000AWG	50-95	23	M12	
	160~240	250AWG	70-120	23	M12	
	200~300	400AWG	95-185	23	M12	
	260~400	500AWG	150-240	23	M12	
	200~300	400AWG	95-185	57	M16	
CGT(H)-800	260~400	500AWG	150-240	57	M16	
	400~600	N°2 40×5	150-185	57	M16	
	520~800	N°2 60×5	185-240	57	M16	

Type	Dimensions of terminal				Type	Dimensions of terminal			
	Main circuit		Auxiliary circuit			Main circuit		Auxiliary circuit	
	Tornillo screw	A × B × C (mm)	Tornillo screw	A × B × C (mm)		Tornillo screw	A × B × C (mm)	Tornillo screw	A × B × C (mm)
CGC-9A(/4)	M4	9.5×5×4.9	M3.5	8×5×4.9	CGT(H)-22	M4	10×6.5×5	M3.5	7.8×4.3×7.3
CGC-12A(/4)	M4	9.5×5×4.9	M3.5	8×5×4.9					
CGC-18A(/4)	M4	9.5×5×4.9	M3.5	8×5×4.9					
CGC-22A(/4)	M4	9.5×5×4.9	M3.5	8×5×4.9					
CGC-32A(/4)	M5	12.4×6.5×6	M3.5	8×5×4.9					
CGC-40A(/4)	M5	12.4×6.5×6	M3.5	8×5×4.9	CGT(H)-40	M5	12.4×6.2×6.3	M3.5	7.8×4.3×7.3
CGC-50A(/4)	M6	17.5×7×8.7	M3.5	8×5×4.9	CGT(H)-85	M6	19×8.5×9	M3.5	7.8×4.3×7.3
CGC-65A(/4)	M8	17.5×7×8.7	M3.5	8×5×4.9		M8	19×8.5×9	M3.5	7.8×4.3×7.3
CGC-75A(/4)	M8	17.5×7×8.7	M3.5	8×5×4.9					
CGC-85A(/4)	M8	17.5×7×8.7	M3.5	8×5×4.9	CGT(H)-125	M8	15×9.5×9	M4	8.2×4.1×5.2
CGC-100(/4)	M8	15×8.5×9.5	M4	10.8×4.1×4.1	CGT(H)-150	M8	20×10×10	M4	8.2×4.1×5.2
CGC-125(/4)	M8	15×8.5×9.5	M4	10.8×4.1×4.1					
CGC-150(/4)	M8	20.5×10×9	M4	10.8×4.1×4.1	CGT(H)-220	M10	25×12.5×13.5	M3.5	7.7×5×4.5
CGC-180(/4)	M10	25×12.5×15	M4	10.8×4.1×4.1	CGT(H)-400	M12	30×15×11	M3.5	7.7×5×4.5
CGC-220(/4)	M10	25×12.5×15	M4	10.8×4.1×4.1					
CGC-300(/4)	M12	30×14.5×20	M4	10.8×4.1×4.1	CGT(H)-800	M16	30×11.2×23.2	M3.5	7.7×5×4.5
CGC-400(/4)	M12	30×14.5×20	M4	10.8×4.1×4.1					
CGC-600(/4)	M16	40×20×40.5	M4	10.8×4.1×4.1					
CGC-800(/4)	M16	40×20×40.5	M4	10.8×4.1×4.1					

Installation and environment

Installation

1) Operating position

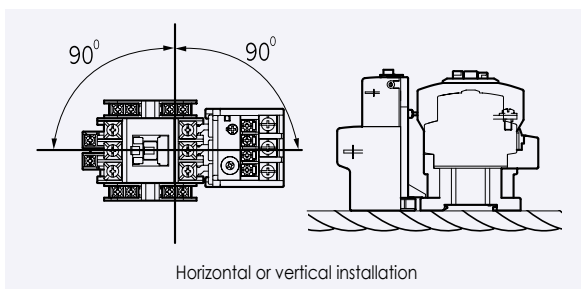
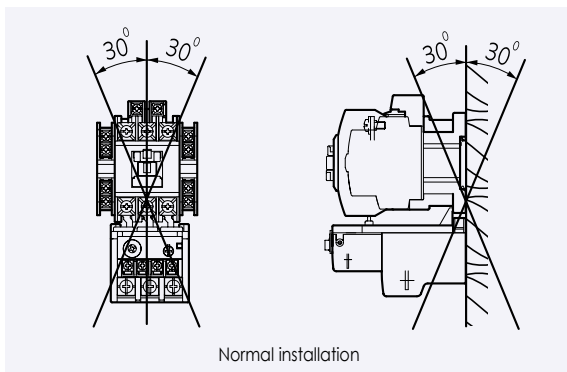

• In special installations, the endurance and other characteristics may be deteriorated.

DIN rail (CGC-9A~85A)

• 35mm DIN rail



Installation

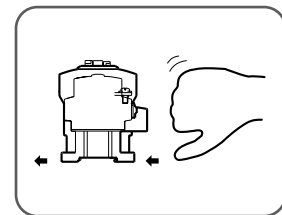

Un-install

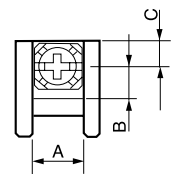

Environment

- 1) Ambient temperature
 - -25~40°C
- 2) Storage temperature
 - -30~65°C
- 3) Altitude : below 2,000m
- 4) Do not install below freezing point.

Dimensions

3-pole Contactors / AC coil

- CGC-9A
- CGC-12A
- CGC-18A
- CGC-22A

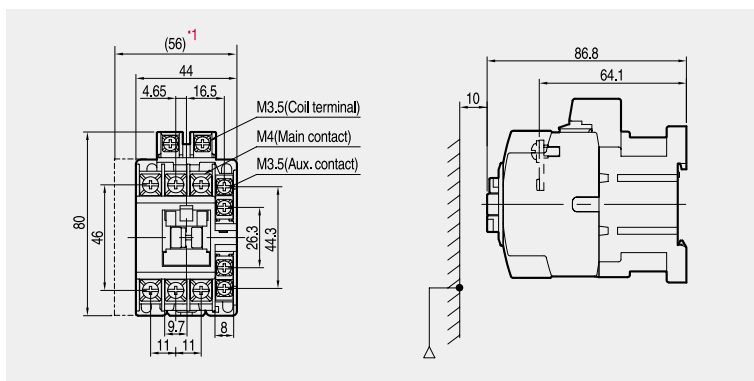

*1 : Optional auxiliary contact unit (side mount type)

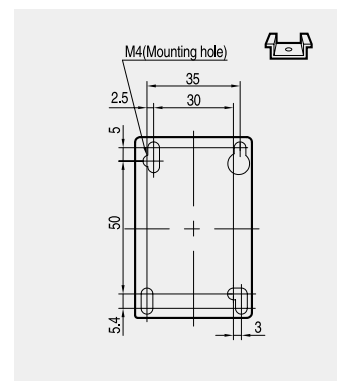

CGC-9A,12:0.33kg
CGC-18A,22:0.37kg

- CGC-32A
- CGC-40A

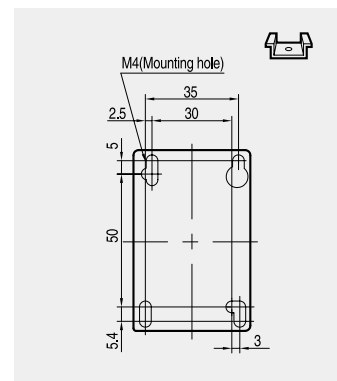
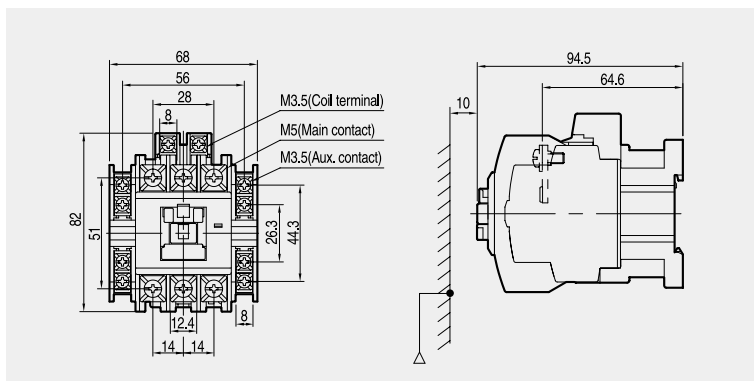

0.45kg

- CGC-50A
- CGC-65A
- CGG-75A
- CGC-85A

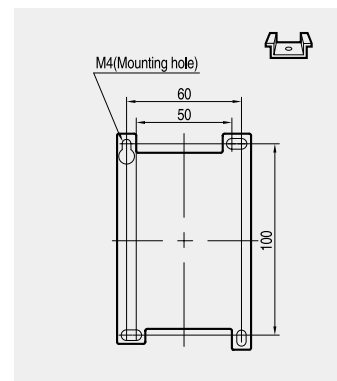
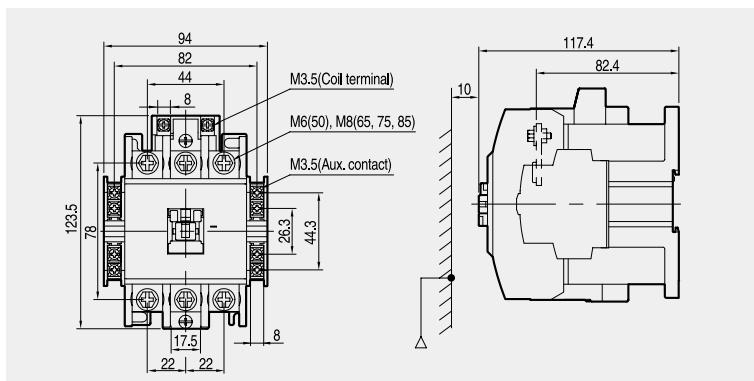

1kg

Circuit diagram

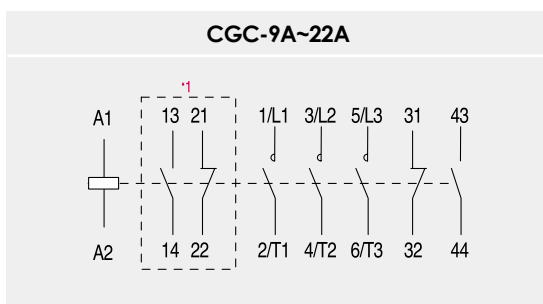

*1 : Optional auxiliary contact unit