

CG2H40045

45 W, DC - 4 GHz RF Power GaN HEMT

Description

Cree's CG2H40045 is an unmatched, gallium nitride (GaN) high electron mobility transistor (HEMT). The CG2H40045, operating from a 28 volt rail, offers a general purpose, broadband solution to a variety of RF and microwave applications. GaN HEMTs offer high efficiency, high gain and wide bandwidth capabilities making the CG2H40045 ideal for linear and compressed amplifier circuits. The transistor is available in a flange and pill package.

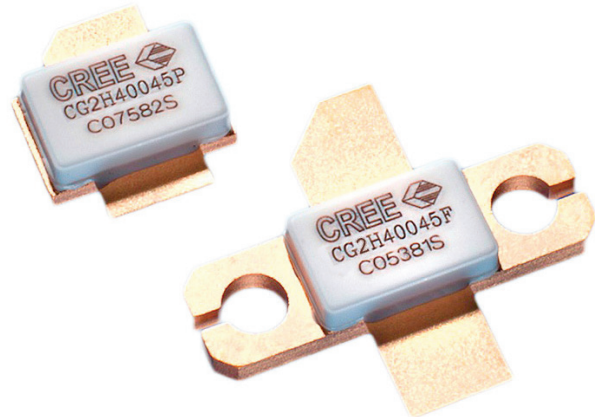

Package Types: 440206 & 440223
PN's: CG2H40045P & CG2H40045F

Features

- Up to 4 GHz Operation
- 18 dB Small Signal Gain at 2.0 GHz
- 14 dB Small Signal Gain at 4.0 GHz
- 55 W Typical P_{SAT}
- 60% Efficiency at P_{SAT}
- 28 V Operation

Applications

- 2-Way Private Radio
- Broadband Amplifiers
- Cellular Infrastructure
- Test Instrumentation
- Class A, AB, Linear amplifiers suitable for OFDM, W-CDMA, EDGE, CDMA waveforms



Absolute Maximum Ratings (not simultaneous) at 25 °C Case Temperature

Parameter	Symbol	Rating	Units	Conditions
Drain-Source Voltage	V_{DSS}	120	Volts	25 °C
Gate-to-Source Voltage	V_{GS}	-10, +2	Volts	25 °C
Storage Temperature	T_{STG}	-65, +150	°C	
Operating Junction Temperature	T_J	225	°C	
Maximum Forward Gate Current	I_{GMAX}	15	mA	25 °C
Maximum Drain Current ¹	I_{DMAX}	6	A	25 °C
Soldering Temperature ²	T_S	245	°C	
Screw Torque	τ	40	in-oz	
Thermal Resistance, Junction to Case ³	$R_{\theta JC}$	2.8	°C/W	85 °C
Case Operating Temperature ^{3,4}	T_C	-40, +150	°C	

Notes:

¹ Current limit for long term, reliable operation

² Refer to the Application Note on soldering at wolfspeed.com/rf/document-library

³ Measured for the CG2H40045F at $P_{DISS} = 56 W$

⁴ See also, the Power Dissipation De-rating Curve on Page 8

Electrical Characteristics ($T_C = 25^\circ C$)

Characteristics	Symbol	Min.	Typ.	Max.	Units	Conditions
DC Characteristics¹						
Gate Threshold Voltage	$V_{GS(th)}$	-3.8	-3.0	-2.3	V_{DC}	$V_{DS} = 10 V, I_D = 14.4 mA$
Gate Quiescent Voltage	$V_{GS(Q)}$	-	-2.7	-	V_{DC}	$V_{DS} = 28 V, I_D = 400 mA$
Saturated Drain Current ²	I_{DS}	10.4	14.4	-	A	$V_{DS} = 6.0 V, V_{GS} = 2.0 V$
Drain-Source Breakdown Voltage	V_{BR}	84	-	-	V_{DC}	$V_{GS} = -8 V, I_D = 14.4 mA$
RF Characteristics³ ($T_C = 25^\circ C, F_0 = 2.5 GHz$ unless otherwise noted)						
Small Signal Gain	G_{SS}	15	17	-	dB	$V_{DD} = 28 V, I_{DQ} = 400 mA$
Power Output ⁴	P_{SAT}	47	55	-	W	$V_{DD} = 28 V, I_{DQ} = 400 mA$
Drain Efficiency ⁵	η	52	62	-	%	$V_{DD} = 28 V, I_{DQ} = 400 mA, P_{OUT} = P_{SAT}$
Output Mismatch Stress	VSWR	-	-	10 : 1	Y	No damage at all phase angles, $V_{DD} = 28 V, I_{DQ} = 400 mA,$ $P_{OUT} = 45 W CW$
Dynamic Characteristics						
Input Capacitance	C_{GS}	-	16.6	-	pF	$V_{DS} = 28 V, V_{GS} = -8 V, f = 1 MHz$
Output Capacitance	C_{DS}	-	6.3	-	pF	$V_{DS} = 28 V, V_{GS} = -8 V, f = 1 MHz$
Feedback Capacitance	C_{GD}	-	0.6	-	pF	$V_{DS} = 28 V, V_{GS} = -8 V, f = 1 MHz$

Notes:

¹ Measured on wafer prior to packaging

² Scaled from PCM data

³ Measured in CG2H40045F-AMP

⁴ P_{SAT} is defined as $I_G = 1.08 mA$

⁵ Drain Efficiency = P_{OUT} / P_{DC}



Typical Performance

Figure 1. Small Signal Gain and Input Return Loss of the CG2H40045F-AMP vs Frequency
 $V_{DD} = 28\text{ V}, I_{DQ} = 400\text{ mA}$

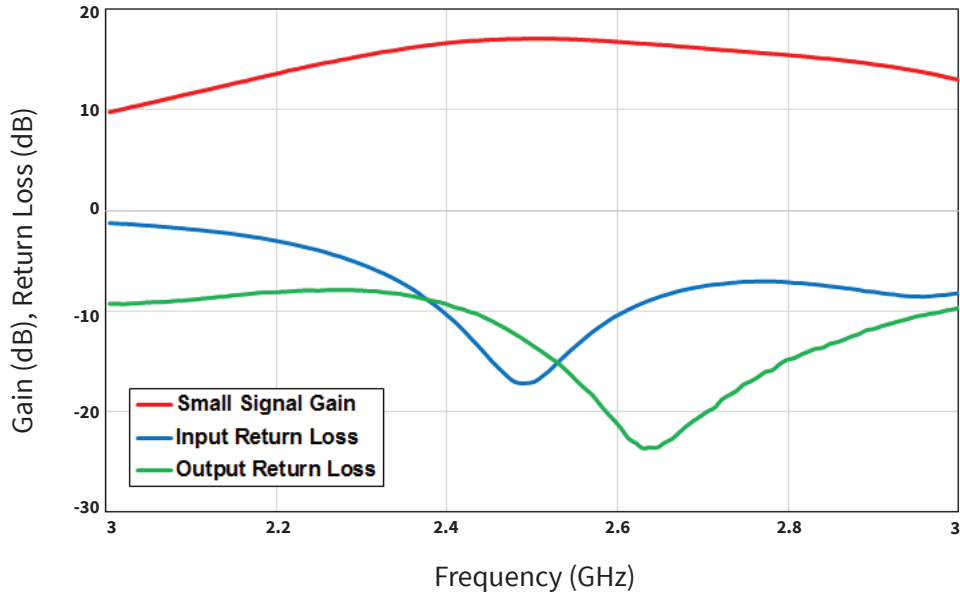
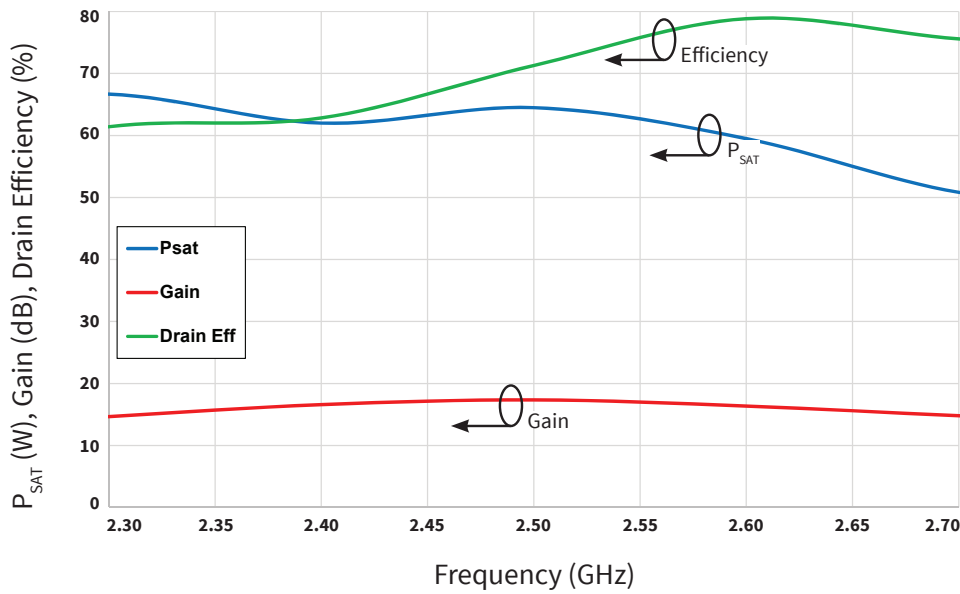

Figure 2. Gain, Efficiency, and Output Power vs Frequency measured in Amplifier Circuit CG2H40045F-AMP
 $V_{DD} = 28\text{ V}, I_{DQ} = 400\text{ mA}$





Typical Performance

Figure 3. Gain and Efficiency vs Output Power measured in Amplifier Circuit CG2H40045F-AMP
 $V_{DD} = 28\text{ V}, I_{DQ} = 400\text{ mA}, \text{Freq} = 2.5\text{ GHz}$

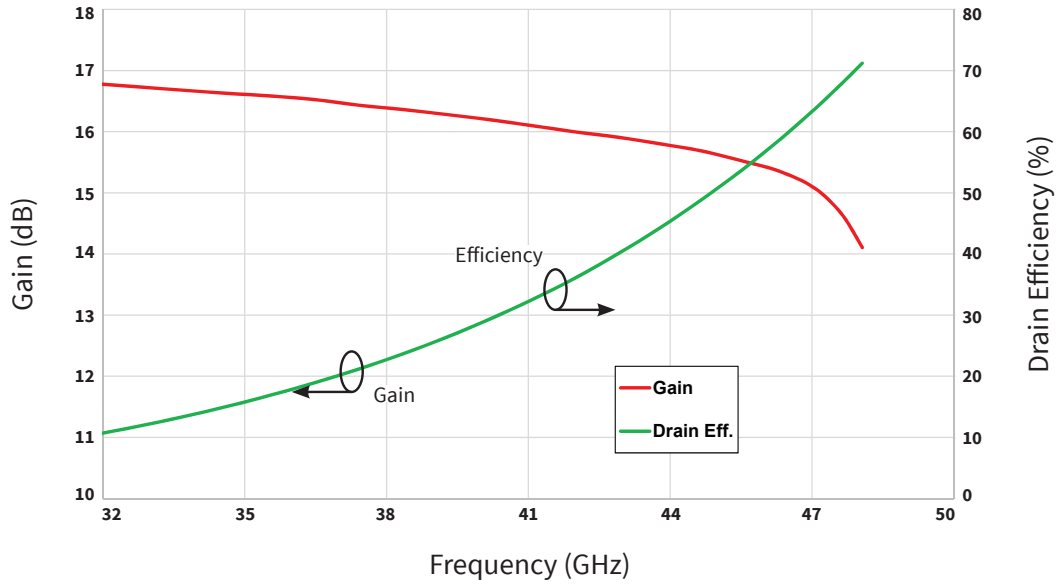
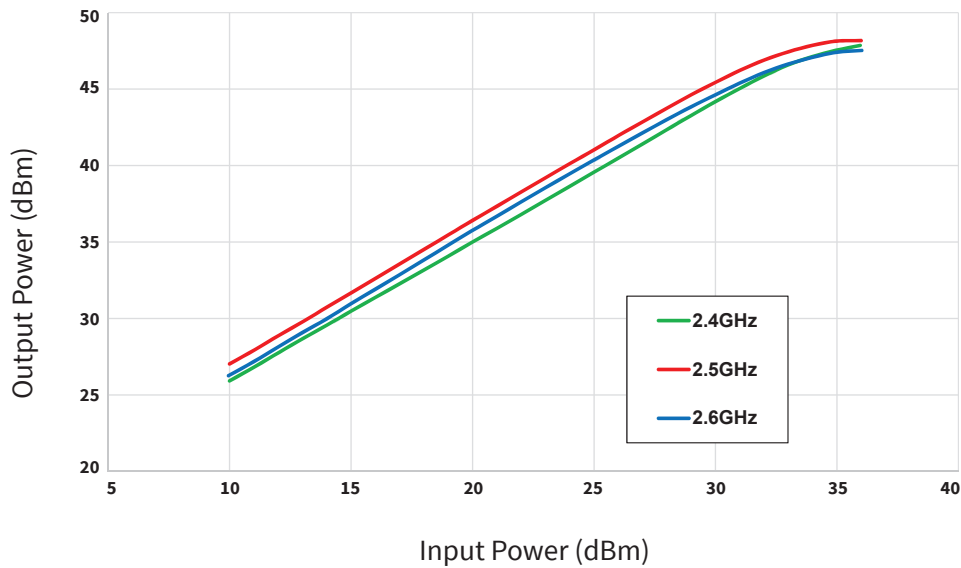

Figure 4. Single Tone CW Output Power vs Input Power of measured in Amplifier Circuit CG2H40045F-AMP
 $V_{DD} = 28\text{ V}, I_{DQ} = 400\text{ mA}$





Typical Performance

Figure 5. Maximum Available Gain and K Factor of the CG2H40045
 $V_{DD} = 28\text{ V}, I_{DQ} = 400\text{ mA}$

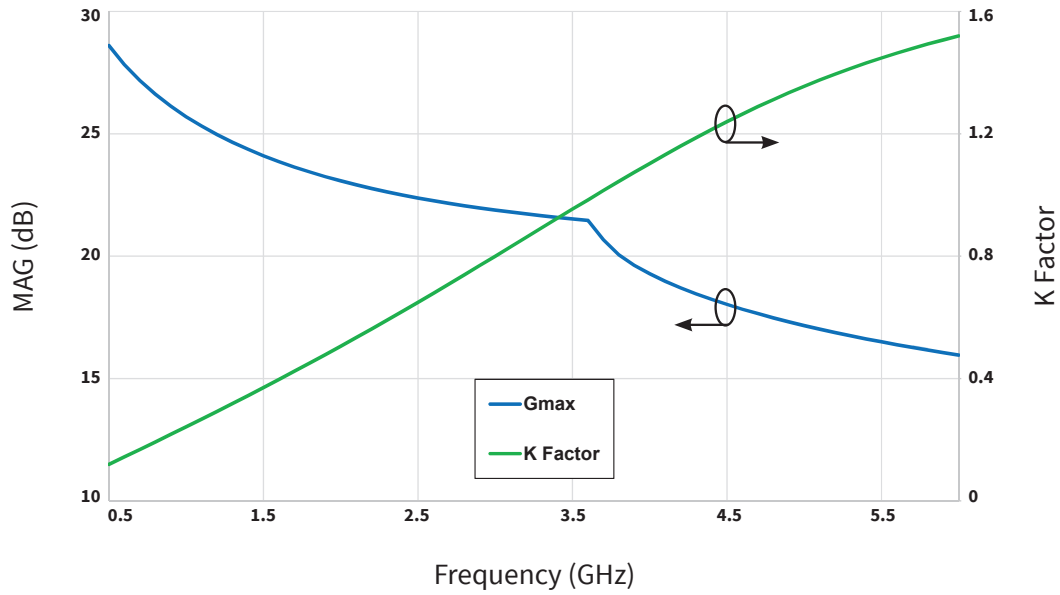
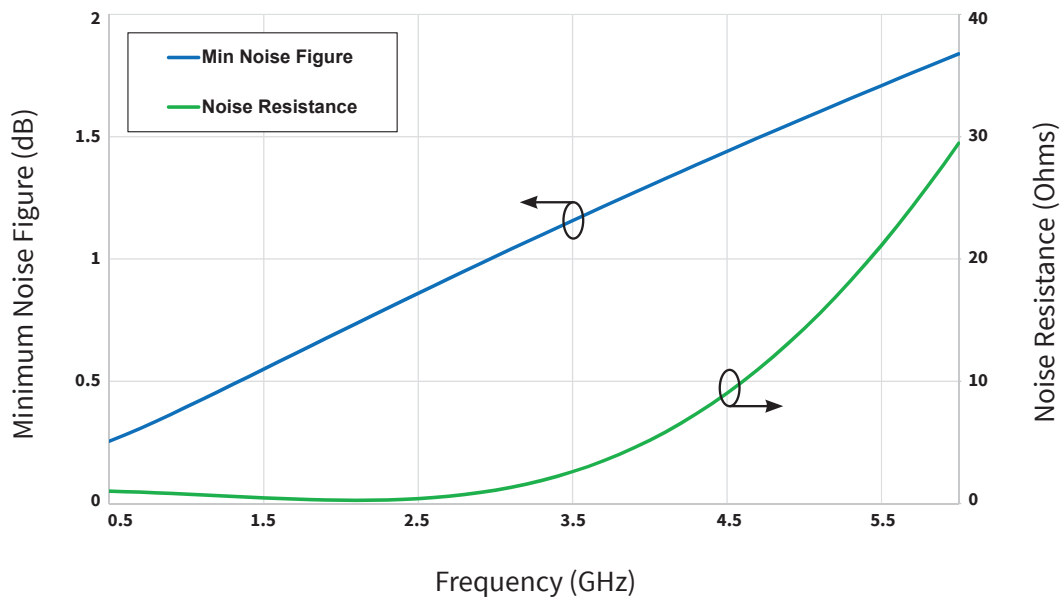

Figure 6. Simulated Minimum Noise Figure and Noise Resistance vs Frequency of the CG2H40045
 $V_{DD} = 28\text{ V}, I_{DQ} = 400\text{ mA}$





Electrostatic Discharge (ESD) Classifications

Parameter	Symbol	Class	Test Methodology
Human Body Model	HBM	1A > 250 V	JEDEC JESD22 A114-D
Charge Device Model	CDM	1 < 200 V	JEDEC JESD22 C101-C



Simulated Source and Load Impedances

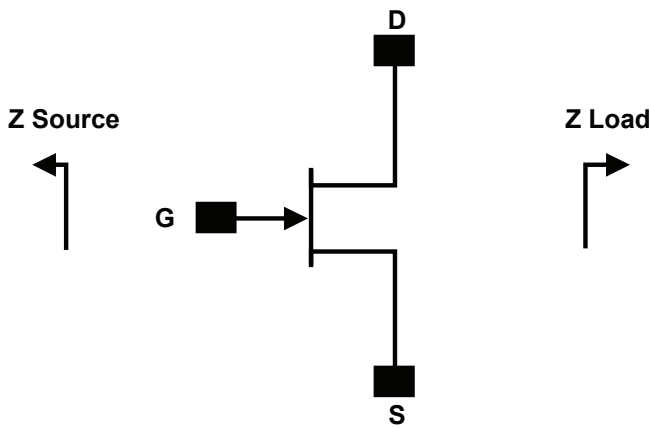

Frequency (MHZ)	Z Source	Z Load
500	4.1 + j5.27	14.73 + j6.91
750	2.9 + j 4.1	12.3 + j 7.6
1000	2.7 + j0.8	9.2 + j1.3
1100	1.9 + j 3.1	9.2 + j6.2
1500	2.1 - j 2.5	6.0 + j4.3
1700	2.2- j2.0	6.5 + j2.3
1800	2.4 - j1.4	7.8 + j1.7
1900	2.8 - j1.8	6.5 + j0.6
2000	2.8 - j1.8	6.5 + j0.6
2100	2.5 - j2.7	5.4 + j0.2
3000	1.4 - j7.3	4.6 - j2.0
4000	2.4 - j11	4.4 - j3.5

Note 1. $V_{DD} = 28V$, $I_{DQ} = 800mA$ in the 440193 package

Note 2. Optimized for power gain, P_{SAT} and PAE

Note 3. When using this device at low frequency, series resistors should be used to maintain amplifier stability

CG2H40045 Power Dissipation De-rating Curve

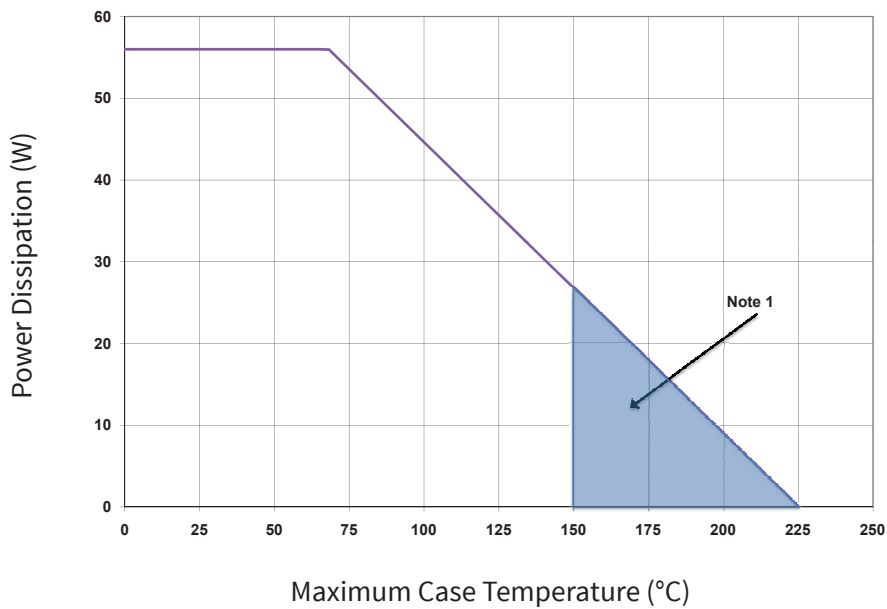

Note 1. Area exceeds Maximum Case Operating Temperature (See Page 2).



CG2H40045-AMP Demonstration Amplifier Circuit Schematic

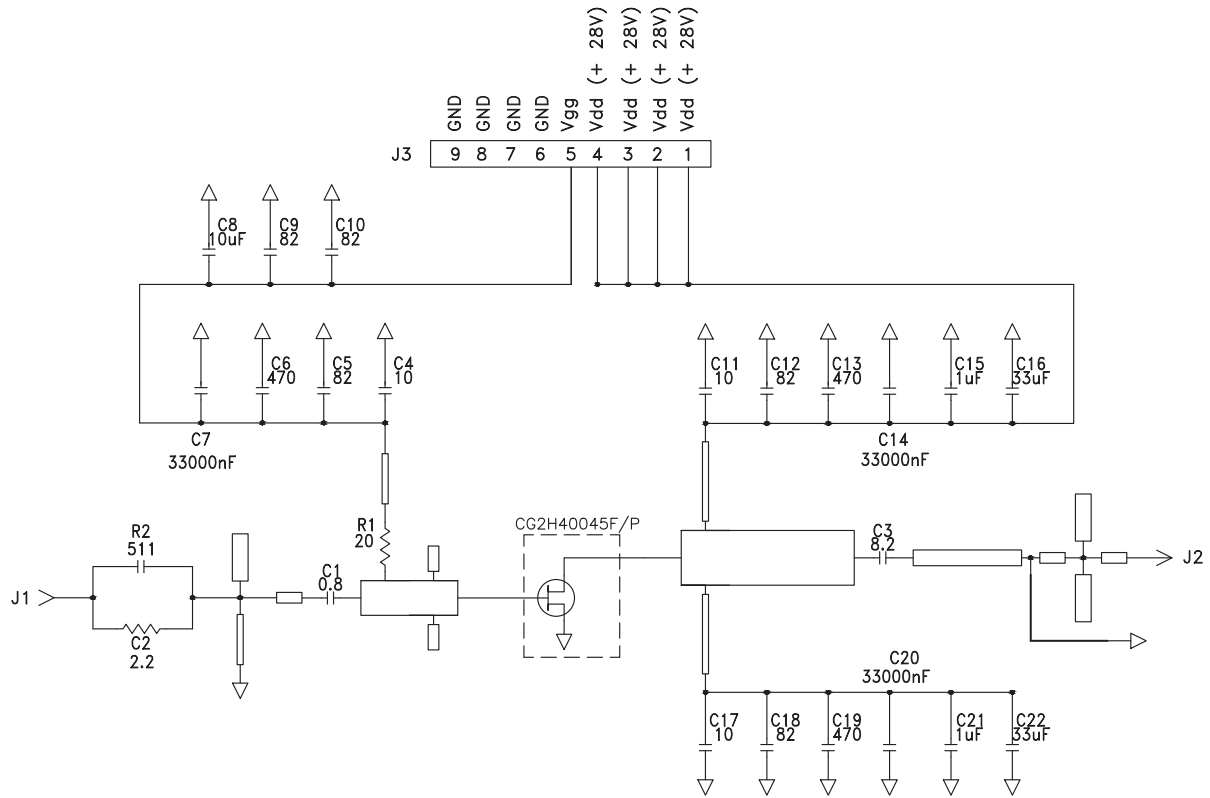

CG2H40045-AMP Demonstration Amplifier Circuit Outline

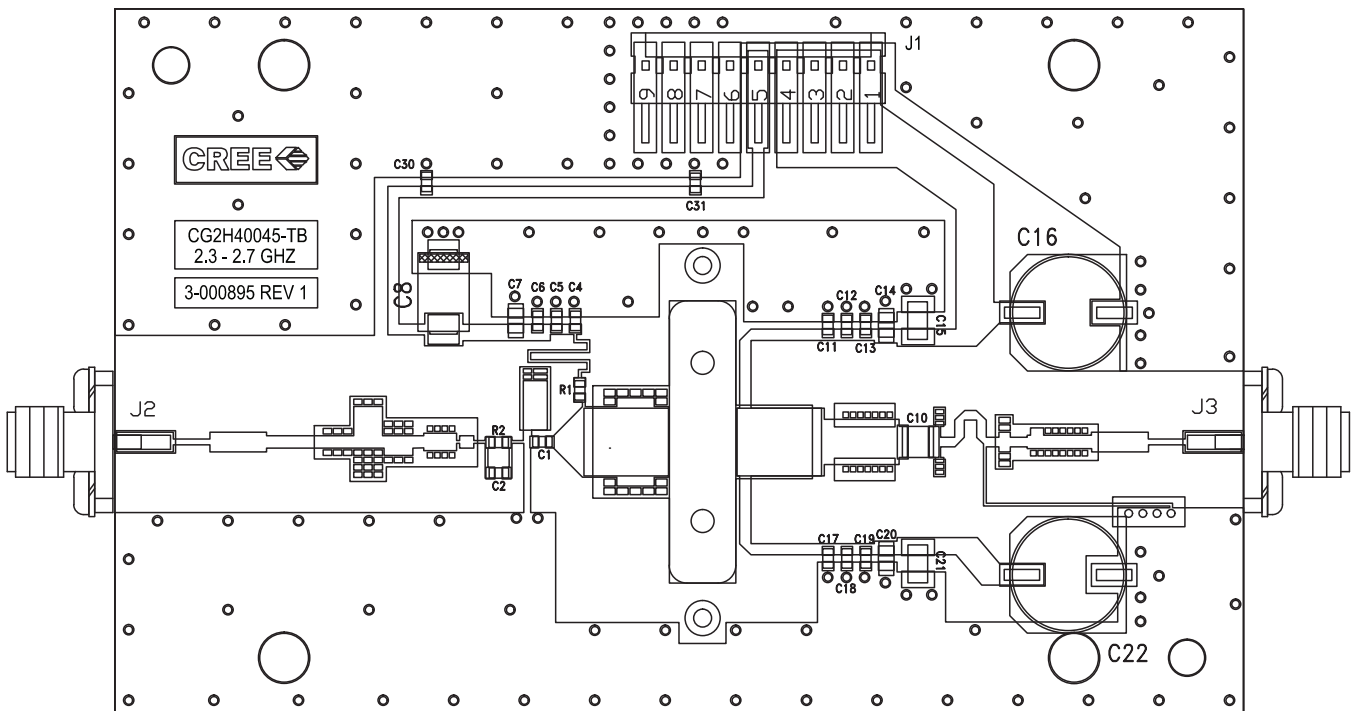

Note: The device slot is machined to different depths to support either pill or flanged versions

CG2H40045-AMP Demonstration Amplifier Circuit Bill of Materials

Designator	Description	Qty
C1	CAP, 0.8pF, ± 0.1 pF, 0603	1
C2	CAP, 2.2pF, ± 0.1 pF, 0603	1
C4, C11, C17	CAP, 10.0pF, +/-5%, 0603, ATC	3
C6, C13, C19	CAP, 470pF ± 5 %, 100 V, 0603, X7R	3
C7, C14, C20	CAP, 33000PF, 0805, 100V, X7R	3
C8	CAP, 10UF, 16V, SMT, TANTALUM	1
C10	CAP, 8.2pF ± 5 %, ATC100B	1
C15, C21	CAP, 1.0UF ± 10 %, 100V, 1210, X7R	2
C5, C12, C18, C30, C31	CAP, 82.0pF, ± 5 %, 0603	5
C16, C22	CAP, 33UF, 20%, G CASE	2
R2	RES, 1/16W, 0603, 100 Ohms 1%	1
R1	RES, 1/16W, 0603, 5.1 Ohms 1%	1
J2, J3	CONN, SMA, PANEL MOUNT JACK, FLANGE	2
J1	CONN, HEADER, RT>PLZ .1CEN LK 9POS	1
-	PCB, RO4350B, Er = 3.48, h = 20 mil	1
Q1	CG2H40045	1

CG2H40045-AMP Demonstration Amplifier Circuit

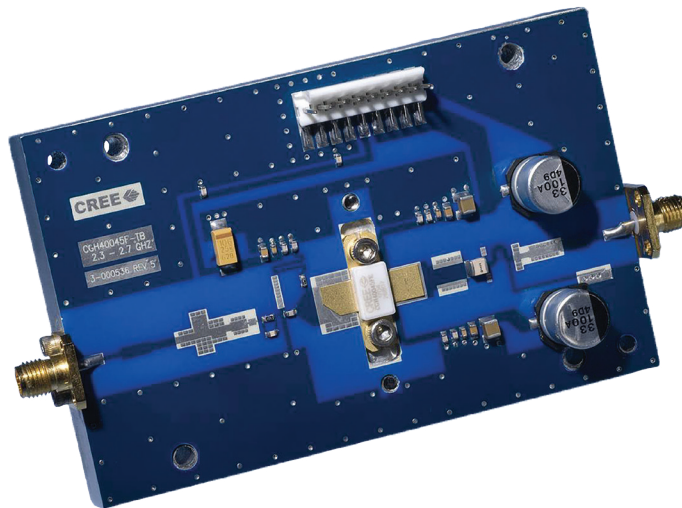

Typical Package S-Parameters for CG2H40045
 (Small Signal, $V_{DS} = 28\text{ V}$, $I_{DQ} = 400\text{ mA}$, angle in degrees)

Frequency	Mag S11	Ang S11	Mag S21	Ang S21	Mag S12	Ang S12	Mag S22	Ang S22
0.500 MHz	0.924	-171.10	9.020	83.83	0.012	-0.74	0.733	-175.20
0.600 MHz	0.924	-173.39	7.526	80.67	0.012	-2.80	0.736	-176.01
0.700 MHz	0.924	-175.16	6.456	77.77	0.012	-4.58	0.738	-176.61
0.800 MHz	0.924	-176.61	5.653	75.04	0.012	-6.20	0.740	-177.08
0.900 MHz	0.925	-177.85	5.027	72.44	0.012	-7.68	0.743	-177.48
1.000 MHz	0.925	-178.94	4.527	69.92	0.012	-9.06	0.745	-177.83
1.100 MHz	0.925	-179.93	4.118	67.47	0.012	-10.36	0.748	-178.15
1.200 MHz	0.925	179.15	3.779	65.08	0.012	-11.59	0.750	-178.46
1.300 MHz	0.926	178.29	3.492	62.74	0.012	-12.76	0.753	-178.76
1.400 MHz	0.926	177.47	3.247	60.45	0.012	-13.87	0.756	-179.06
1.500 MHz	0.926	176.68	3.035	58.19	0.012	-14.93	0.758	-179.37
1.600 MHz	0.927	175.91	2.851	55.97	0.012	-15.93	0.761	-179.69
1.700 MHz	0.927	175.15	2.690	53.78	0.012	-16.89	0.764	179.98
1.800 MHz	0.927	174.41	2.548	51.62	0.012	-17.79	0.767	179.64
1.900 MHz	0.928	173.66	2.423	49.49	0.011	-18.65	0.769	179.28
2.000 MHz	0.928	172.92	2.311	47.38	0.011	-19.46	0.772	178.91
2.100 MHz	0.928	172.18	2.211	45.30	0.011	-20.23	0.774	178.53
2.200 MHz	0.928	171.43	2.121	43.24	0.011	-20.95	0.777	178.12
2.300 MHz	0.928	170.67	2.041	41.20	0.011	-21.63	0.779	177.70
2.400 MHz	0.928	169.90	1.969	39.17	0.011	-22.27	0.781	177.27
2.500 MHz	0.928	169.12	1.905	37.17	0.011	-22.87	0.783	176.81
2.600 MHz	0.928	168.32	1.847	35.17	0.011	-23.43	0.785	176.34
2.700 MHz	0.928	167.51	1.795	33.19	0.011	-23.95	0.787	175.85
2.800 MHz	0.927	166.67	1.748	31.22	0.011	-24.44	0.788	175.34
2.900 MHz	0.927	165.82	1.707	29.25	0.011	-24.90	0.790	174.82
3.000 MHz	0.926	164.94	1.670	27.29	0.011	-25.32	0.791	174.27
3.200 MHz	0.925	163.09	1.609	23.37	0.011	-26.10	0.793	173.13
3.400 MHz	0.923	161.12	1.564	19.43	0.011	-26.81	0.794	171.90
3.600 MHz	0.921	158.99	1.533	15.44	0.011	-27.47	0.794	170.59
3.800 MHz	0.918	156.67	1.515	11.38	0.011	-28.13	0.793	169.19
4.000 MHz	0.914	154.13	1.510	7.20	0.011	-28.86	0.791	167.68
4.200 MHz	0.910	151.31	1.519	2.88	0.012	-29.69	0.787	166.06
4.400 MHz	0.904	148.17	1.541	-1.65	0.012	-30.72	0.783	164.31
4.600 MHz	0.897	144.63	1.577	-6.44	0.013	-32.03	0.777	162.41
4.800 MHz	0.888	140.59	1.630	-11.56	0.013	-33.71	0.769	160.34
5.000 MHz	0.877	135.92	1.701	-17.09	0.014	-35.87	0.759	158.07
5.200 MHz	0.864	130.47	1.791	-23.15	0.016	-38.66	0.747	155.55
5.400 MHz	0.848	124.02	1.905	-29.86	0.017	-42.23	0.732	152.73
5.600 MHz	0.828	116.27	2.045	-37.39	0.019	-46.76	0.715	149.54
5.800 MHz	0.804	106.83	2.212	-45.93	0.021	-52.46	0.693	145.87
6.000 MHz	0.775	95.17	2.407	-55.72	0.023	-59.58	0.668	141.58

To download the s-parameters in s2p format, go to the [CGH40045 Product page](#) and click on the documentation tab.

Typical Package S-Parameters for CG2H40045 (Small Signal, $V_{DS} = 28\text{ V}$, $I_{DQ} = 800\text{ mA}$, angle in degrees)

Frequency	Mag S11	Ang S11	Mag S21	Ang S21	Mag S12	Ang S12	Mag S22	Ang S22
0.500 MHz	0.939	-172.50	8.967	84.35	0.010	1.41	0.762	-177.28
0.600 MHz	0.939	-174.64	7.489	81.47	0.010	-0.03	0.763	-178.00
0.700 MHz	0.939	-176.32	6.432	78.83	0.010	-1.23	0.764	-178.57
0.800 MHz	0.939	-177.71	5.639	76.33	0.010	-2.28	0.765	-179.05
0.900 MHz	0.939	-178.91	5.024	73.94	0.010	-3.21	0.767	-179.47
1.000 MHz	0.939	-179.98	4.532	71.62	0.010	-4.05	0.768	-179.85
1.100 MHz	0.939	179.05	4.131	69.36	0.010	-4.82	0.769	179.79
1.200 MHz	0.939	178.15	3.798	67.15	0.010	-5.54	0.770	179.44
1.300 MHz	0.939	177.29	3.518	64.97	0.009	-6.20	0.771	179.10
1.400 MHz	0.939	176.47	3.279	62.82	0.009	-6.81	0.773	178.77
1.500 MHz	0.939	175.67	3.073	60.70	0.009	-7.38	0.774	178.43
1.600 MHz	0.939	174.90	2.894	58.61	0.009	-7.90	0.775	178.09
1.700 MHz	0.938	174.13	2.737	56.54	0.009	-8.39	0.777	177.74
1.800 MHz	0.938	173.38	2.600	54.49	0.009	-8.83	0.778	177.38
1.900 MHz	0.938	172.63	2.478	52.45	0.009	-9.24	0.779	177.01
2.000 MHz	0.938	171.87	2.370	50.43	0.009	-9.61	0.780	176.64
2.100 MHz	0.938	171.12	2.274	48.42	0.009	-9.95	0.781	176.25
2.200 MHz	0.937	170.36	2.188	46.43	0.009	-10.25	0.782	175.85
2.300 MHz	0.937	169.59	2.111	44.44	0.009	-10.53	0.783	175.43
2.400 MHz	0.937	168.80	2.043	42.47	0.009	-10.77	0.784	175.00
2.500 MHz	0.936	168.01	1.981	40.50	0.009	-10.98	0.785	174.56
2.600 MHz	0.936	167.20	1.926	38.53	0.009	-11.17	0.785	174.10
2.700 MHz	0.935	166.37	1.877	36.57	0.009	-11.34	0.786	173.63
2.800 MHz	0.934	165.52	1.833	34.61	0.009	-11.49	0.786	173.14
2.900 MHz	0.934	164.65	1.795	32.65	0.009	-11.62	0.786	172.63
3.000 MHz	0.933	163.75	1.761	30.69	0.010	-11.74	0.786	172.11
3.200 MHz	0.931	161.87	1.705	26.74	0.010	-11.97	0.786	171.00
3.400 MHz	0.928	159.85	1.665	22.74	0.010	-12.20	0.784	169.82
3.600 MHz	0.925	157.66	1.640	18.67	0.010	-12.49	0.782	168.56
3.800 MHz	0.921	155.28	1.628	14.50	0.011	-12.89	0.779	167.20
4.000 MHz	0.917	152.67	1.630	10.19	0.011	-13.46	0.775	165.75
4.200 MHz	0.912	149.77	1.645	5.71	0.012	-14.26	0.770	164.17
4.400 MHz	0.905	146.53	1.675	1.00	0.012	-15.37	0.763	162.48
4.600 MHz	0.897	142.86	1.721	-4.00	0.013	-16.87	0.754	160.63
4.800 MHz	0.887	138.67	1.784	-9.36	0.014	-18.85	0.744	158.62
5.000 MHz	0.875	133.82	1.865	-15.16	0.015	-21.43	0.731	156.41
5.200 MHz	0.860	128.15	1.969	-21.52	0.017	-24.72	0.717	153.98
5.400 MHz	0.842	121.43	2.096	-28.57	0.019	-28.86	0.699	151.27
5.600 MHz	0.820	113.34	2.250	-36.47	0.021	-34.03	0.678	148.22
5.800 MHz	0.794	103.490	2.432	-45.404	0.023	-40.418	0.654	144.730
6 MHz	0.76376	91.356	2.6393	-55.605	0.025877	-48.247	0.6254	140.65

To download the s-parameters in s2p format, go to the [CGH40045 Product page](#) and click on the documentation tab.

Product Dimensions CG2H40045F (Package Type — 440223)

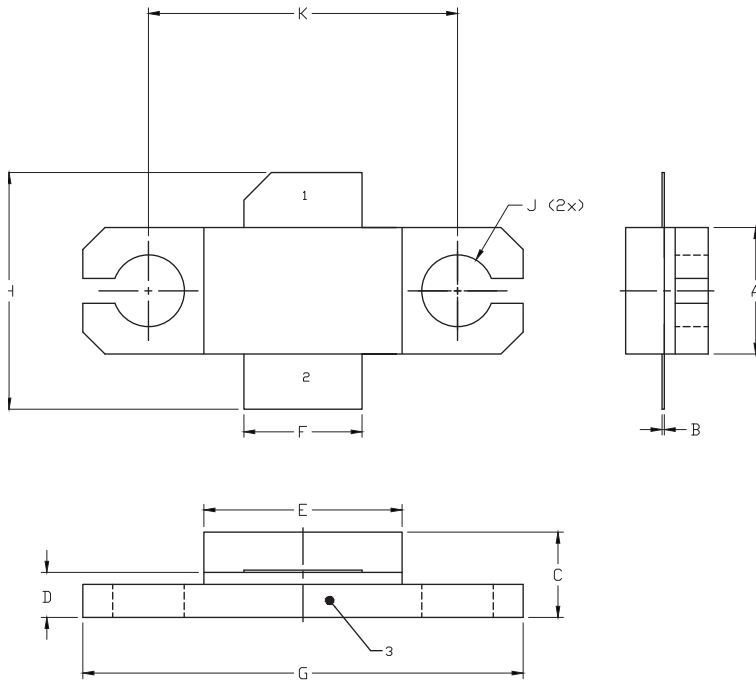

- NOTES:
1. DIMENSIONING AND TOLERANCING PER ANSI Y14.5M, 1982.
 2. CONTROLLING DIMENSION: INCH.
 3. ADHESIVE FROM LID MAY EXTEND A MAXIMUM OF 0.020" BEYOND EDGE OF LID.
 4. LID MAY BE MISALIGNED TO THE BODY OF THE PACKAGE BY A MAXIMUM OF 0.008" IN ANY DIRECTION.
 5. ALL PLATED SURFACES ARE NI/AU

DIM	INCHES		MILLIMETERS	
	MIN	MAX	MIN	MAX
A	0.225	0.235	5.72	5.97
B	0.004	0.006	0.10	0.15
C	0.145	0.165	3.68	4.19
D	0.077	0.087	1.96	2.21
E	0.355	0.365	9.02	9.27
F	0.210	0.220	5.33	5.59
G	0.795	0.805	20.19	20.45
H	0.400	0.460	10.16	11.68
J	∅ .130		3.30	
k	0.562		14.27	

PIN 1. GATE
 PIN 2. DRAIN
 PIN 3. SOURCE

Product Dimensions CG2H40045P (Package Type — 440206)

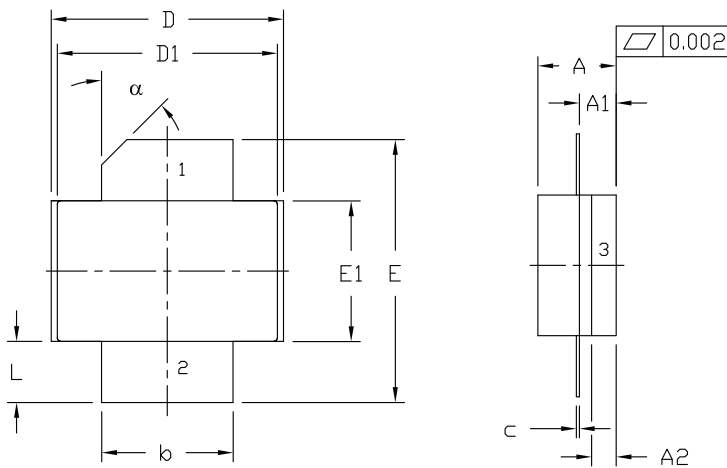



- NOTES:
1. DIMENSIONING AND TOLERANCING PER ANSI Y14.5M - 1994.
 2. CONTROLLING DIMENSION: INCH.
 3. ADHESIVE FROM LID MAY EXTEND A MAXIMUM OF 0.020" BEYOND EDGE OF LID.
 4. LID MAY BE MISALIGNED TO THE BODY OF PACKAGE BY A MAXIMUM OF 0.008" IN ANY DIRECTION.

DIM	INCHES		MILLIMETERS		NOTES
	MIN	MAX	MIN	MAX	
A	0.125	0.145	3.18	3.68	
A1	0.057	0.067	1.45	1.70	
A2	0.035	0.045	0.89	1.14	
b	0.210	0.220	5.33	5.59	2x
c	0.004	0.006	0.10	0.15	2x
D	0.375	0.385	9.53	9.78	
D1	0.355	0.365	9.02	9.27	
E	0.400	0.460	10.16	11.68	
E1	0.225	0.235	5.72	5.97	
L	0.085	0.115	2.16	2.92	2x
α	45°	REF	45°	REF	

PIN 1. GATE
 2. DRAIN
 3. SOURCE

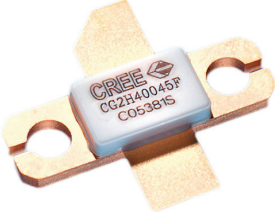

Product Ordering Information

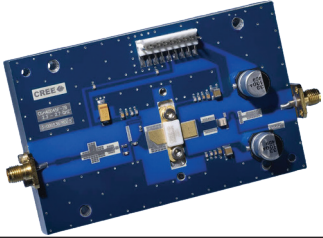
Order Number	Description	Unit of Measure	Image
CG2H40045F	GaN HEMT	Each	
CG2H40045P	GaN HEMT	Each	
CG2H40045F-AMP	Test board with GaN HEMT installed	Each	



For more information, please contact:

4600 Silicon Drive
Durham, North Carolina, USA 27703
www.wolfspeed.com/rf

Sales Contact
rfsales@cree.com

Notes & Disclaimer

Specifications are subject to change without notice. “Typical” parameters are the average values expected by Cree in large quantities and are provided for information purposes only. Cree products are not warranted or authorized for use as critical components in medical, life-saving, or life-sustaining applications, or other applications where a failure would reasonably be expected to cause severe personal injury or death. No responsibility is assumed by Cree for any infringement of patents or other rights of third parties which may result from use of the information contained herein. No license is granted by implication or otherwise under any patent or patent rights of Cree.

© 2017 – 2021 Cree, Inc. All rights reserved. Wolfspeed® and the Wolfspeed logo are registered trademarks of Cree, Inc.