

Low-Voltage 1:10 LVPECL with Selectable Input Clock Driver

Check for Samples: [CDCLVP111](#)

FEATURES

- Distributes One Differential Clock Input Pair LVPECL to 10 Differential LVPECL
- Fully Compatible With LVECL/LVPECL
- Supports a Wide Supply Voltage Range From 2.375 V to 3.8 V
- Selectable Clock Input Through CLK_SEL
- Low-Output Skew (Typ 15 ps) for Clock-Distribution Applications
 - Additive Jitter Less Than 1 ps
 - Propagation Delay Less Than 350 ps
 - Open Input Default State
 - LVDS, CML, SSTL input compatible
- V_{BB} Reference Voltage Output for Single-Ended Clocking
- Available in a 32-Pin LQFP and QFN Package
- Frequency Range From DC to 3.5 GHz
- Pin-to-Pin Compatible With MC100 Series EP111, ES6111, LVEP111, PTN1111

APPLICATIONS

- Designed for Driving 50 Ω Transmission Lines
- High Performance Clock Distribution

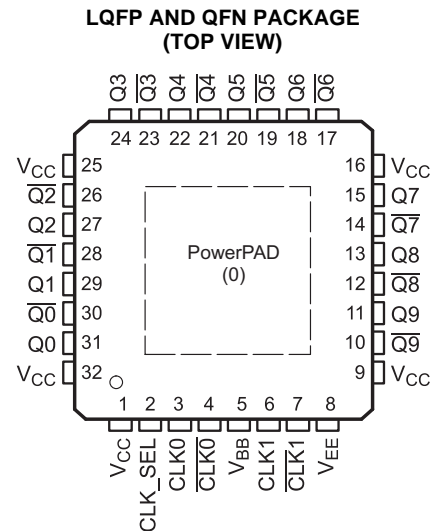

DESCRIPTION

The CDCLVP111 clock driver distributes one differential clock pair of LVPECL input, (CLK0, CLK1) to ten pairs of differential LVPECL clock (Q0, Q9) outputs with minimum skew for clock distribution. The CDCLVP111 can accept two clock sources into an input multiplexer. The CDCLVP111 is specifically designed for driving 50- Ω transmission lines. When an output pin is not used, leaving it open is recommended to reduce power consumption. If only one of the output pins from a differential pair is used, the other output pin must be identically terminated to 50 Ω .

The V_{BB} reference voltage output is used if single-ended input operation is required. In this case, the V_{BB} pin should be connected to CLK0 and bypassed to GND via a 10-nF capacitor.

However, for high-speed performance up to 3.5 GHz, the differential mode is strongly recommended.

The CDCLVP111 is characterized for operation from -40°C to 85°C .

Table 1. FUNCTION TABLE

CLK_SEL	ACTIVE CLOCK INPUT
0	CLK0, $\overline{\text{CLK0}}$
1	CLK1, $\overline{\text{CLK1}}$



Please be aware that an important notice concerning availability, standard warranty, and use in critical applications of Texas Instruments semiconductor products and disclaimers thereto appears at the end of this data sheet.

PowerPAD is a trademark of Texas Instruments.

PRODUCTION DATA information is current as of publication date. Products conform to specifications per the terms of the Texas Instruments standard warranty. Production processing does not necessarily include testing of all parameters.

Copyright © 2009–2011, Texas Instruments Incorporated

CDCLVP111

SCAS859E – JANUARY 2009 – REVISED JULY 2011

www.ti.com



These devices have limited built-in ESD protection. The leads should be shorted together or the device placed in conductive foam during storage or handling to prevent electrostatic damage to the MOS gates.

DEVICE INFORMATION

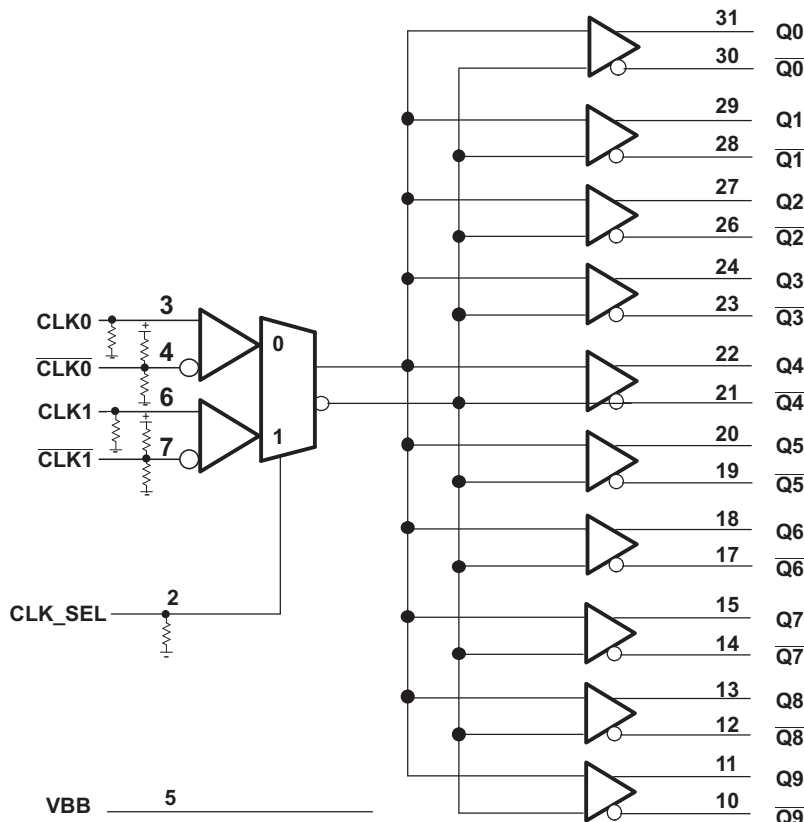

PIN FUNCTIONS⁽¹⁾

PIN		DESCRIPTION
NAME	NO.	
CLK_SEL	2	Clock select. Used to select between CLK0 and CLK1 input pairs. LVTTTL/LVCMOS functionality compatible.
CLK0, $\overline{\text{CLK0}}$	3, 4	Differential LVECL/LVPECL input pair
CLK1, $\overline{\text{CLK1}}$	6, 7	
Q [9:0]	11, 13, 15, 18, 20, 22, 24, 27, 29, 31	LVECL/LVPECL clock outputs, these outputs provide low-skew copies of CLKn.
$\overline{\text{Q}}[9:0]$	10, 12, 14, 17, 19, 21, 23, 26, 28, 30	LVECL/LVPECL complementary clock outputs, these outputs provide copies of $\overline{\text{CLKn}}$.
V _{BB}	5	Reference voltage output for single-ended input operation
V _{CC}	1, 9, 16, 25, 32	Supply voltage
V _{EE}	8	Device ground or negative supply voltage in ECL mode
PowerPAD™	0	The PowerPAD of the QFN32 is thermally connected to the die to improve the heat transfer out of the package. The pad of the QFN32 with PowerPAD must be connected to V _{EE} .

(1) CLKn, CLK_SEL pull down resistor = 75 kΩ; $\overline{\text{CLKn}}$ pull up resistor = 37.5 kΩ; $\overline{\text{CLKn}}$ pull down resistor = 50 kΩ.

ABSOLUTE MAXIMUM RATINGS⁽¹⁾

		VALUE	UNIT
V_{CC}	Supply voltage (Relative to V_{EE})	–0.3 to 4.6	V
V_I	Input voltage	–0.3 to $V_{CC} + 0.5$	V
V_O	Output voltage	–0.3 to $V_{CC} + 0.5$	V
I_{IN}	Input current	±20	mA
V_{EE}	Negative supply voltage (Relative to V_{CC})	–4.6 to 0.3	V
I_{BB}	Sink/source current	–1 to 1	mA
I_O	DC output current	–50	mA
T_{stg}	Storage temperature range	–65 to 150	°C
T_J	Maximum operating junction temperature	125	°C

(1) Stresses beyond those listed under "absolute maximum ratings" may cause permanent damage to the device. These are stress ratings only, and functional operation of the device at these or any other conditions beyond those indicated under "recommended operating conditions" is not implied. Exposure to absolute-maximum-rated conditions for extended periods may affect device reliability.

RECOMMENDED OPERATING CONDITIONS

		MIN	NOM	MAX	UNIT
V_{CC}	Supply voltage (relative to V_{EE})	2.375	2.5/3.3	3.8	V
T_A	Operating free-air temperature	–40		85	°C/W
T_J	Operating junction temperature			110	°C

PACKAGE THERMAL IMPEDANCE, VF (LQFP)

		TEST CONDITION	VALUE	UNIT
θ_{JA}	Thermal resistance junction to ambient ⁽¹⁾	0 LFM	74	°C/W
		150 LFM	66	°C/W
		250 LFM	64	°C/W
		500 LFM	61	°C/W
θ_{JC}	Thermal resistance junction to case		39	°C/W

(1) According to JESD 51-7 standard.

PACKAGE THERMAL IMPEDANCE, RHB (QFN)

		TEST CONDITION	VALUE	UNIT
θ_{JA}	Thermal resistance junction to ambient ⁽¹⁾	0 LFM	49	°C/W
		150 LFM	37	°C/W
		250 LFM	36	°C/W
		500 LFM	32	°C/W
θ_{JC}	Thermal resistance junction to case		19	°C/W

(1) According to JESD 51-7 standard.

CDCLVP111

SCAS859E – JANUARY 2009 – REVISED JULY 2011

www.ti.com

LVECL DC ELECTRICAL CHARACTERISTICS

Vsupply: $V_{CC} = 0\text{ V}$, $V_{EE} = -2.375\text{ V}$ to -3.8 V over operating free-air temperature range (unless otherwise noted)

PARAMETER	TEST CONDITIONS	MIN	TYP	MAX	UNIT		
I_{EE} Supply internal current	Absolute value of current	-40°C, 25°C, 85°C		40	85	mA	
I_{CC} Output and internal supply current	All outputs terminated 50 Ω to $V_{CC} - 2\text{ V}$	-40°C			354	mA	
		25°C			380		
		85°C			405		
I_{IN} Input current	Includes pullup/pulldown resistors, $V_{IH} = V_{CC}$, $V_{IL} = V_{CC} - 2\text{ V}$	-40°C, 25°C, 85°C		-150	150	μA	
V_{BB} Internally generated bias voltage	For $V_{EE} = -3$ to -3.8 V , $I_{BB} = -0.2\text{ mA}$	-40°C, 25°C, 85°C		-1.45	-1.3	-1.15	V
	$V_{EE} = -2.375$ to -2.75 V , $I_{BB} = -0.2\text{ mA}$	-40°C, 25°C, 85°C		-1.4	-1.25	-1.1	
V_{IH} High-level input voltage (CLK_SEL)		-40°C, 25°C, 85°C		-1.165		-0.88	V
V_{IL} Low-level input voltage (CLK_SEL)		-40°C, 25°C, 85°C		-1.81		-1.475	V
V_{ID} Input amplitude (CLKn, $\overline{\text{CLKn}}$)	Difference of input, See ⁽¹⁾ $ V_{IH} - V_{IL} $	-40°C, 25°C, 85°C		0.5		1.3	V
V_{CM} Common-mode voltage (CLKn, $\overline{\text{CLKn}}$)	DC offset relative to V_{EE}	-40°C, 25°C, 85°C		$V_{EE} + 1$		-0.3	V
V_{OH} High-level output voltage	$I_{OH} = -21\text{ mA}$	-40°C		-1.26		-0.85	V
		25°C		-1.2		-0.85	
		85°C		-1.15		-0.85	
V_{OL} Low-level output voltage	$I_{OL} = -5\text{ mA}$	-40°C		-1.85		-1.5	V
		25°C		-1.85		-1.45	
		85°C		-1.85		-1.4	
V_{OD} Differential output voltage swing	Terminated with 50 Ω to $V_{CC} - 2\text{ V}$, See Figure 4	-40°C, 25°C, 85°C		600			mV

(1) V_{ID} minimum and maximum is required to maintain ac specifications, actual device function tolerates a minimum V_{ID} of 100 mV.

LVPECL DC ELECTRICAL CHARACTERISTICS

Vsupply: $V_{CC} = 2.375\text{ V to }3.8\text{ V}$, $V_{EE} = 0\text{ V}$ over operating free-air temperature range (unless otherwise noted)

PARAMETER	TEST CONDITIONS	MIN	TYP	MAX	UNIT			
I_{EE}	Supply internal current	Absolute value of current		-40°C, 25°C, 85°C	40	85	mA	
I_{CC}	Output and internal supply current	All outputs terminated 50 Ω to $V_{CC} - 2\text{ V}$		-40°C		354	mA	
				25°C		380		
				85°C		405		
I_{IN}	Input current	Includes pullup/pulldown resistors $V_{IH} = V_{CC}$, $V_{IL} = V_{CC} - 2\text{ V}$		-40°C, 25°C, 85°C	-150	150	μA	
V_{BB}	Internally generated bias voltage	$V_{CC} = 3\text{ to }3.8\text{ V}$, $I_{BB} = -0.2\text{ mA}$		-40°C, 25°C, 85°C	$V_{CC} - 1.45$	$V_{CC} - 1.3$	$V_{CC} - 1.15$	V
		$V_{CC} = 2.375\text{ to }2.75\text{ V}$, $I_{BB} = -0.2\text{ mA}$		-40°C, 25°C, 85°C	$V_{CC} - 1.4$	$V_{CC} - 1.25$	$V_{CC} - 1.1$	
V_{IH}	High-level input voltage (CLK_SEL)			-40°C, 25°C, 85°C	$V_{CC} - 1.165$	$V_{CC} - 0.88$	V	
V_{IL}	Low-level input voltage (CLK_SEL)			-40°C, 25°C, 85°C	$V_{CC} - 1.81$	$V_{CC} - 1.475$	V	
V_{ID}	Input amplitude (CLKn, $\overline{\text{CLKn}}$)	Difference of input, see (1), $ V_{IH} - V_{IL} $		-40°C, 25°C, 85°C	0.5	1.3	V	
V_{CM}	Common-mode voltage (CLKn, $\overline{\text{CLKn}}$)	DC offset relative to V_{EE}		-40°C, 25°C, 85°C	1	$V_{CC} - 0.3$	V	
V_{OH}	High-level output voltage	$I_{OH} = -21\text{ mA}$		-40°C	$V_{CC} - 1.26$	$V_{CC} - 0.85$	V	
				25°C	$V_{CC} - 1.2$	$V_{CC} - 0.85$		
				85°C	$V_{CC} - 1.15$	$V_{CC} - 0.85$		
V_{OL}	Low-level output voltage	$I_{OL} = -5\text{ mA}$		-40°C	$V_{CC} - 1.85$	$V_{CC} - 1.5$	V	
				25°C	$V_{CC} - 1.85$	$V_{CC} - 1.45$		
				85°C	$V_{CC} - 1.85$	$V_{CC} - 1.4$		
V_{OD}	Differential output voltage swing	Terminated with 50 Ω to $V_{CC} - 2\text{ V}$, See Figure 4		-40°C, 25°C, 85°C	600		mV	

(1) V_{ID} minimum and maximum is required to maintain ac specifications, actual device function tolerates a minimum V_{ID} of 100 mV.

AC ELECTRICAL CHARACTERISTICS

Vsupply: $V_{CC} = 2.375\text{ V to }3.8\text{ V}$, $V_{EE} = 0\text{ V}$ or LVECL/LVPECL input $V_{CC} = 0\text{ V}$, $V_{EE} = -2.375\text{ V to }-3.8\text{ V}$ over operating free-air temperature range (unless otherwise noted)

PARAMETER	TEST CONDITIONS	MIN	TYP	MAX	UNIT	
t_{pd}	Differential propagation delay CLKn, $\overline{\text{CLKn}}$ to all Q0, Q0... Q9, Q9	See		200	350	ps
$t_{sk(o)}$	Output-to-output skew	See , and Figure 1		15	30	ps
$t_{sk(pp)}$	Part-to-part skew	See , and Figure 1			70	ps
t_{aj}	Additive phase jitter	Integration bandwidth of 20 kHz to 20 MHz, $f_{out} = 125\text{ MHz}$ at 25°C		0.04	< 0.8	ps
$f_{(max)}$	Maximum frequency	Functional up to 3.5 GHz, see Figure 4			3500	MHz
t_r/t_f	Output rise and fall time (20%, 80%)	See Note D in Figure 1		90	200	ps

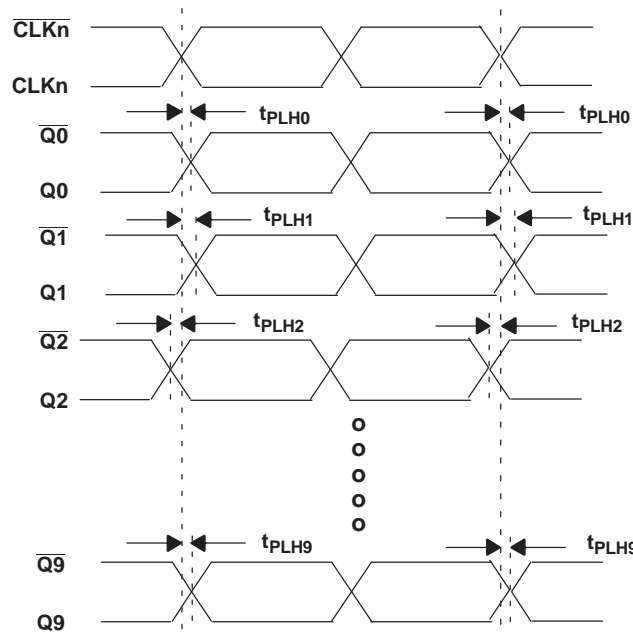

- A. Output skew is calculated as the greater of: The difference between the fastest and the slowest t_{PLHn} ($n = 0, 1, \dots, 9$) or the difference between the fastest and the slowest t_{pHLn} ($n = 0, 1, \dots, 9$).
- B. Part-to-part skew, is calculated as the greater of: The difference between the fastest and the slowest t_{PLHn} ($n = 0, 1, \dots, 9$) across multiple devices or the difference between the fastest and the slowest t_{pHLn} ($n = 0, 1, \dots, 9$) across multiple devices.
- C. Typical value measured at ambient when clock input is 155.52MHz for an integration bandwidth of 20 kHz to 5 MHz.
- D. Input conditions: $V_{CM} = 1\text{ V}$, $V_{ID} = 0.5\text{ V}$ and $F_{IN} = 1\text{ GHz}$.

Figure 1. Waveform for Calculating Both Output and Part-to-Part Skew

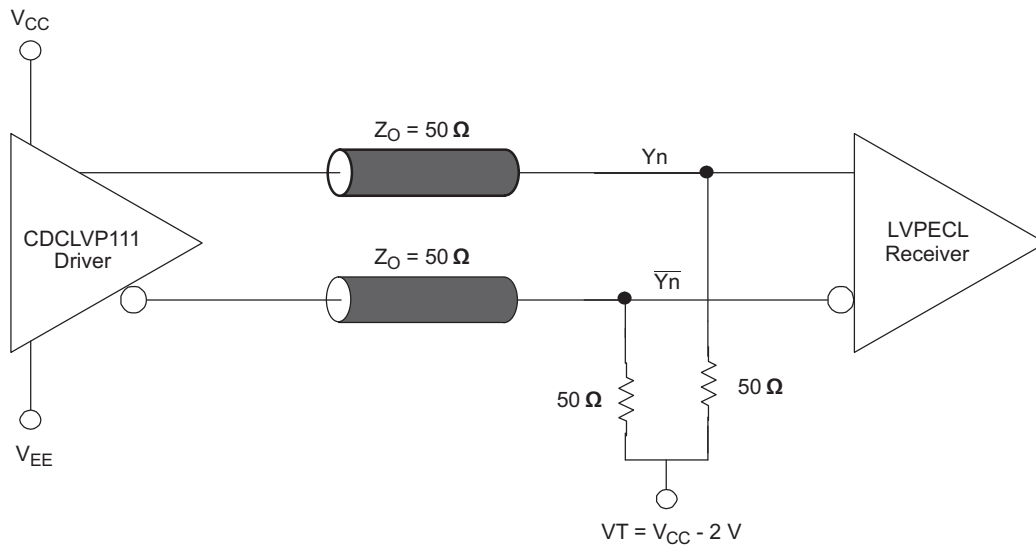

Figure 2. Typical Termination for Output Driver (See the Interfacing Between LVPECL, LVDS, and CML Application Note, Literature Number [SCAA056](#))

Figure 3. DIFFERENTIAL OUTPUT VOLTAGE SWING
VS
FREQUENCY

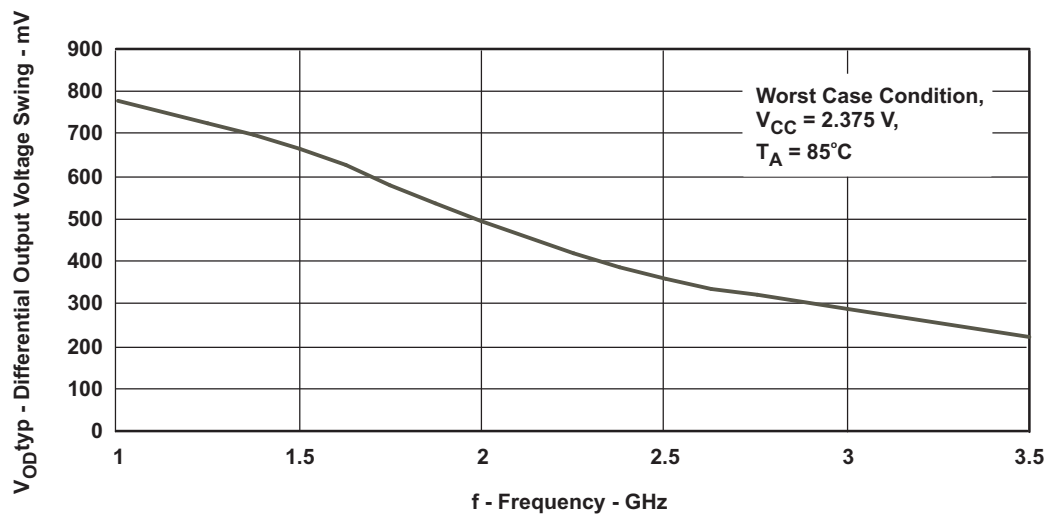

Figure 4. LVPECL Input Using CLK0 Pair, V_{CM} = 1 V, V_{ID} = 0.5 V

REVISION HISTORY

Changes from Original (January 2009) to Revision A	Page
• Changed note refernces within the AC ELECTRICAL CHARACTERISTICS table	5
• Added a Typ value of 0.04ps to the Additive phase jitter in the AC ELECTRICAL CHARACTERISTICS	5
Changes from Revision A (March 2009) to Revision B	Page
• Added LVTTTL/LVCMOS functionality compatible.	2
Changes from Revision B (April 2009) to Revision C	Page
• Changed PowerPAD information to the Pinout Package	1
• Added PowerPAD information to the Pin Functions table	2
Changes from Revision C (November 2009) to Revision D	Page
• Changed the PowerPAD description in the PIN FUNCTIONS table to include the LQFP package information.	2
• Deleted duplicate information covering the PowerPAD from Note 1 of the Pin Functions table.	2
Changes from Revision D (March 2010) to Revision E	Page
• Changed the PowerPAD Pin Function Description	2
• Added text "See Note D in Figure 1" to the t_r/t_f Test Conditions in the AC ELECTRICAL CHARACTERITICS table	5

PACKAGING INFORMATION

Orderable Device	Status (1)	Package Type	Package Drawing	Pins	Package Qty	Eco Plan (2)	Lead/Ball Finish	MSL Peak Temp (3)	Op Temp (°C)	Device Marking (4/5)	Samples
CDCLVP111RHBR	ACTIVE	VQFN	RHB	32	3000	Green (RoHS & no Sb/Br)	CU NIPDAU	Level-2-260C-1 YEAR	-40 to 85	LVP111	Samples
CDCLVP111RHBT	ACTIVE	VQFN	RHB	32	250	Green (RoHS & no Sb/Br)	CU NIPDAU	Level-2-260C-1 YEAR	-40 to 85	LVP111	Samples
CDCLVP111VF	ACTIVE	LQFP	VF	32	250	Green (RoHS & no Sb/Br)	CU NIPDAU	Level-1-260C-UNLIM	-40 to 85	CDCLVP111	Samples
CDCLVP111VFR	ACTIVE	LQFP	VF	32	1000	Green (RoHS & no Sb/Br)	CU NIPDAU	Level-1-260C-UNLIM	-40 to 85	CDCLVP111	Samples

(1) The marketing status values are defined as follows:

ACTIVE: Product device recommended for new designs.

LIFEBUY: TI has announced that the device will be discontinued, and a lifetime-buy period is in effect.

NRND: Not recommended for new designs. Device is in production to support existing customers, but TI does not recommend using this part in a new design.

PREVIEW: Device has been announced but is not in production. Samples may or may not be available.

OBSOLETE: TI has discontinued the production of the device.

(2) Eco Plan - The planned eco-friendly classification: Pb-Free (RoHS), Pb-Free (RoHS Exempt), or Green (RoHS & no Sb/Br) - please check <http://www.ti.com/productcontent> for the latest availability information and additional product content details.

TBD: The Pb-Free/Green conversion plan has not been defined.

Pb-Free (RoHS): TI's terms "Lead-Free" or "Pb-Free" mean semiconductor products that are compatible with the current RoHS requirements for all 6 substances, including the requirement that lead not exceed 0.1% by weight in homogeneous materials. Where designed to be soldered at high temperatures, TI Pb-Free products are suitable for use in specified lead-free processes.

Pb-Free (RoHS Exempt): This component has a RoHS exemption for either 1) lead-based flip-chip solder bumps used between the die and package, or 2) lead-based die adhesive used between the die and leadframe. The component is otherwise considered Pb-Free (RoHS compatible) as defined above.

Green (RoHS & no Sb/Br): TI defines "Green" to mean Pb-Free (RoHS compatible), and free of Bromine (Br) and Antimony (Sb) based flame retardants (Br or Sb do not exceed 0.1% by weight in homogeneous material)

(3) MSL, Peak Temp. -- The Moisture Sensitivity Level rating according to the JEDEC industry standard classifications, and peak solder temperature.

(4) There may be additional marking, which relates to the logo, the lot trace code information, or the environmental category on the device.

(5) Multiple Device Markings will be inside parentheses. Only one Device Marking contained in parentheses and separated by a "~" will appear on a device. If a line is indented then it is a continuation of the previous line and the two combined represent the entire Device Marking for that device.

Important Information and Disclaimer: The information provided on this page represents TI's knowledge and belief as of the date that it is provided. TI bases its knowledge and belief on information provided by third parties, and makes no representation or warranty as to the accuracy of such information. Efforts are underway to better integrate information from third parties. TI has taken and

continues to take reasonable steps to provide representative and accurate information but may not have conducted destructive testing or chemical analysis on incoming materials and chemicals. TI and TI suppliers consider certain information to be proprietary, and thus CAS numbers and other limited information may not be available for release.

In no event shall TI's liability arising out of such information exceed the total purchase price of the TI part(s) at issue in this document sold by TI to Customer on an annual basis.

OTHER QUALIFIED VERSIONS OF CDCLVP111 :

- Enhanced Product: [CDCLVP111-EP](#)

NOTE: Qualified Version Definitions:

- Enhanced Product - Supports Defense, Aerospace and Medical Applications

TAPE AND REEL INFORMATION

QUADRANT ASSIGNMENTS FOR PIN 1 ORIENTATION IN TAPE

*All dimensions are nominal

Device	Package Type	Package Drawing	Pins	SPQ	Reel Diameter (mm)	Reel Width W1 (mm)	A0 (mm)	B0 (mm)	K0 (mm)	P1 (mm)	W (mm)	Pin1 Quadrant
CDCLVP111RHBR	VQFN	RHB	32	3000	330.0	12.4	5.3	5.3	1.5	8.0	12.0	Q2
CDCLVP111RHBT	VQFN	RHB	32	250	180.0	12.4	5.3	5.3	1.5	8.0	12.0	Q2
CDCLVP111VFR	LQFP	VF	32	1000	330.0	16.4	9.6	9.6	1.9	12.0	16.0	Q2

TAPE AND REEL BOX DIMENSIONS

*All dimensions are nominal

Device	Package Type	Package Drawing	Pins	SPQ	Length (mm)	Width (mm)	Height (mm)
CDCLVP111RHBR	VQFN	RHB	32	3000	338.1	338.1	20.6
CDCLVP111RHBT	VQFN	RHB	32	250	210.0	185.0	35.0
CDCLVP111VFR	LQFP	VF	32	1000	367.0	367.0	38.0

RHB (S-PVQFN-N32)

PLASTIC QUAD FLATPACK NO-LEAD

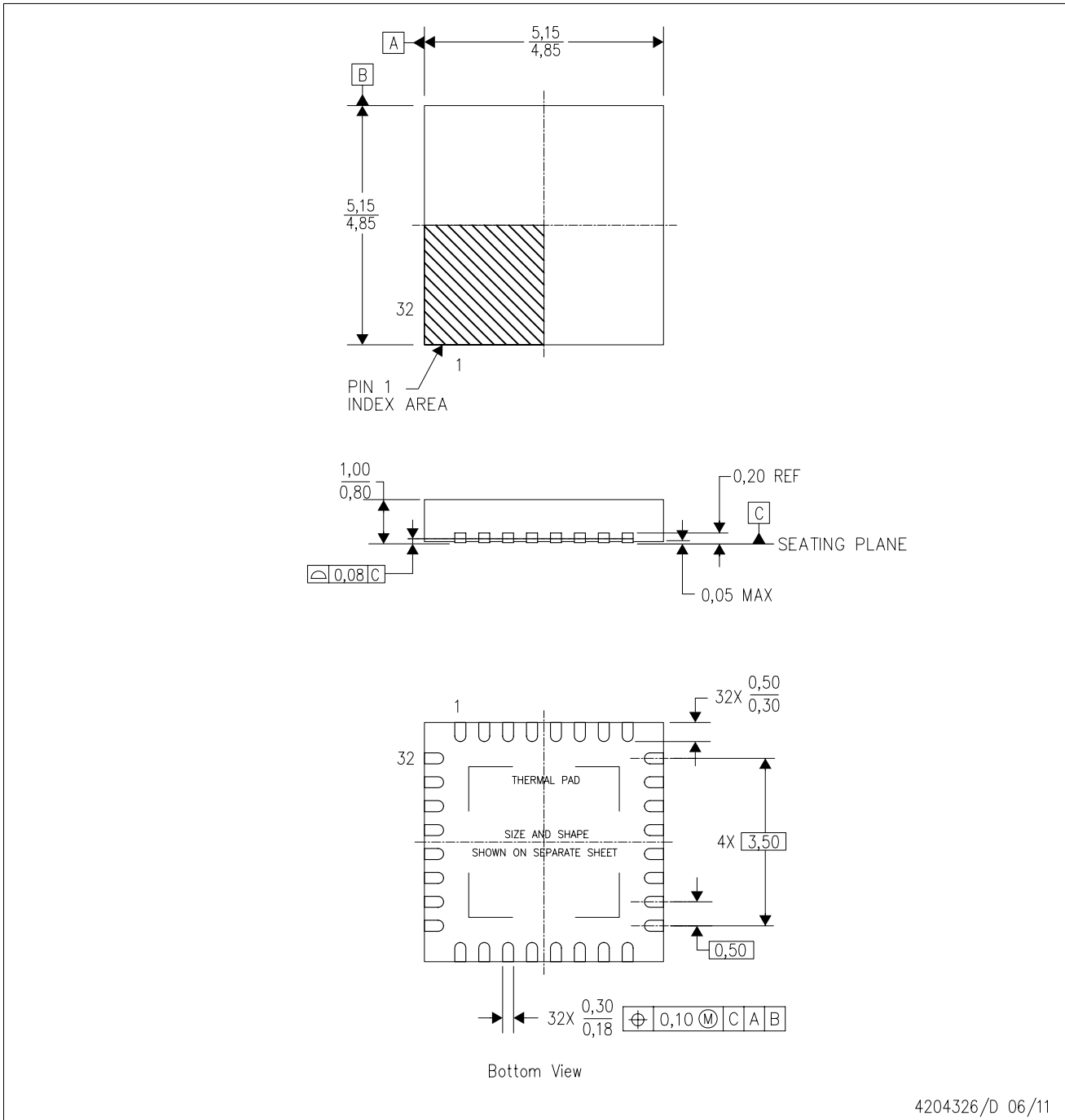

4204326/D 06/11

- NOTES:
- All linear dimensions are in millimeters. Dimensioning and tolerancing per ASME Y14.5M-1994.
 - This drawing is subject to change without notice.
 - QFN (Quad Flatpack No-Lead) Package configuration.
 - The package thermal pad must be soldered to the board for thermal and mechanical performance.
 - See the additional figure in the Product Data Sheet for details regarding the exposed thermal pad features and dimensions.
 - Falls within JEDEC MO-220.

THERMAL INFORMATION

This package incorporates an exposed thermal pad that is designed to be attached directly to an external heatsink. The thermal pad must be soldered directly to the printed circuit board (PCB). After soldering, the PCB can be used as a heatsink. In addition, through the use of thermal vias, the thermal pad can be attached directly to the appropriate copper plane shown in the electrical schematic for the device, or alternatively, can be attached to a special heatsink structure designed into the PCB. This design optimizes the heat transfer from the integrated circuit (IC).

For information on the Quad Flatpack No-Lead (QFN) package and its advantages, refer to Application Report, QFN/SON PCB Attachment, Texas Instruments Literature No. SLUA271. This document is available at www.ti.com.

The exposed thermal pad dimensions for this package are shown in the following illustration.

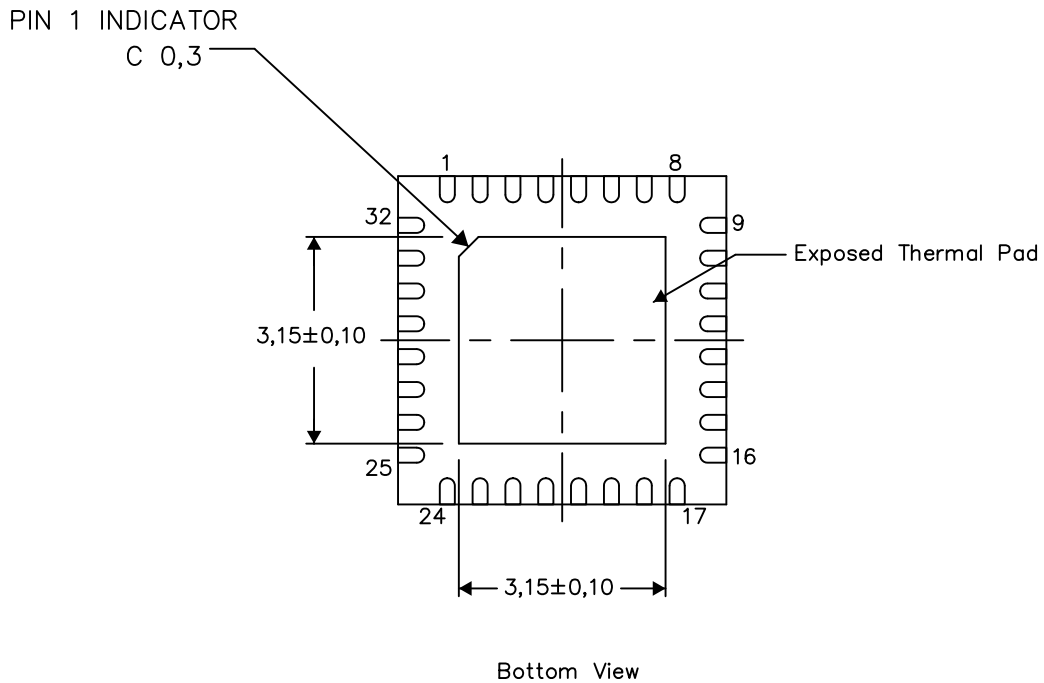

Exposed Thermal Pad Dimensions

4206356-3/Y 06/13

NOTE: A. All linear dimensions are in millimeters

RHB (S-PVQFN-N32)

PLASTIC QUAD FLATPACK NO-LEAD

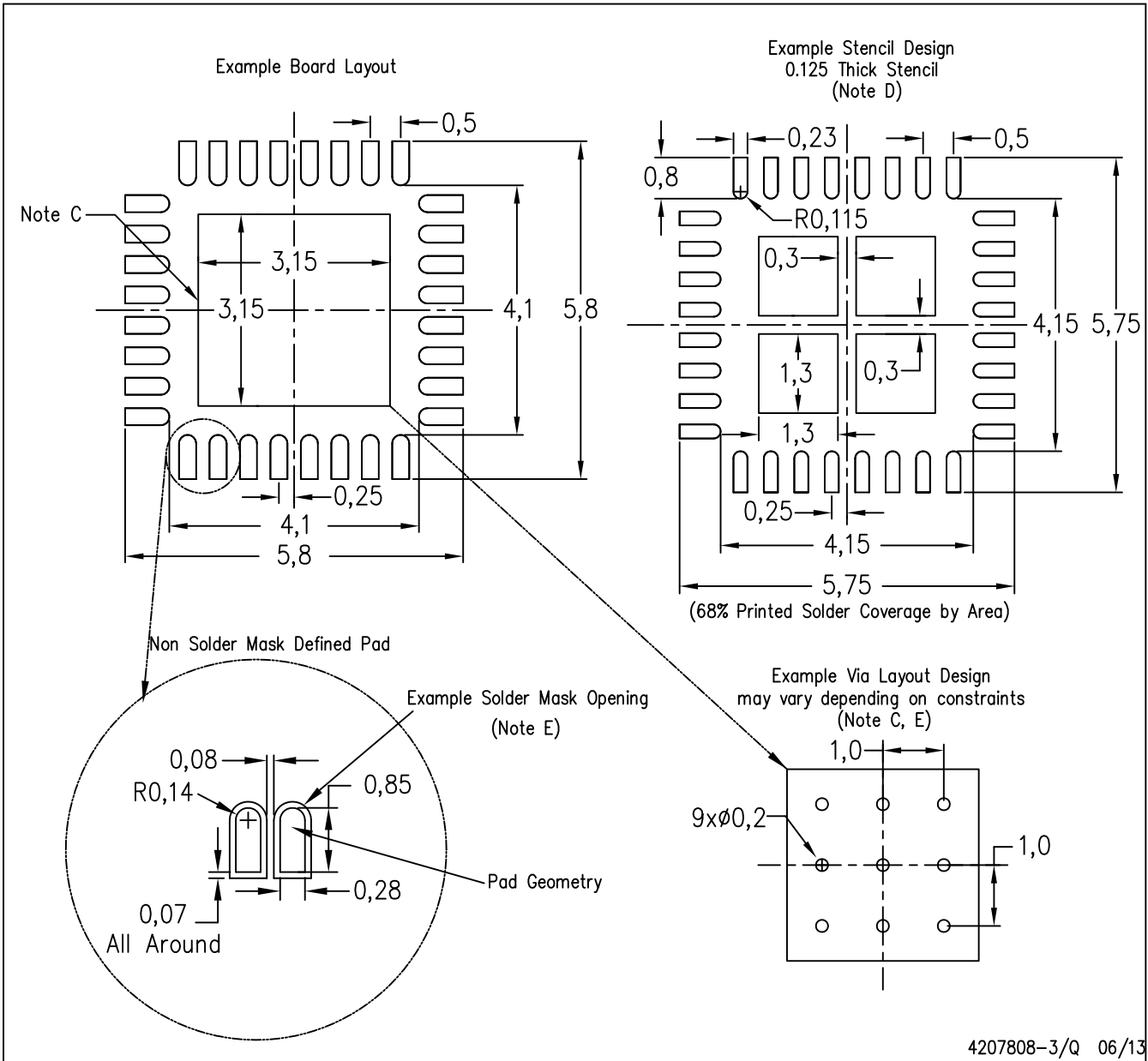

- NOTES:
- A. All linear dimensions are in millimeters.
 - B. This drawing is subject to change without notice.
 - C. This package is designed to be soldered to a thermal pad on the board. Refer to Application Note, Quad Flat-Pack Packages, Texas Instruments Literature No. SLUA271, and also the Product Data Sheets for specific thermal information, via requirements, and recommended board layout. These documents are available at www.ti.com <<http://www.ti.com>>.
 - D. Laser cutting apertures with trapezoidal walls and also rounding corners will offer better paste release. Customers should contact their board assembly site for stencil design recommendations. Refer to IPC 7525 for stencil design considerations.
 - E. Customers should contact their board fabrication site for recommended solder mask tolerances and via tenting recommendations for vias placed in the thermal pad.

VF (S-PQFP-G32)

PLASTIC QUAD FLATPACK

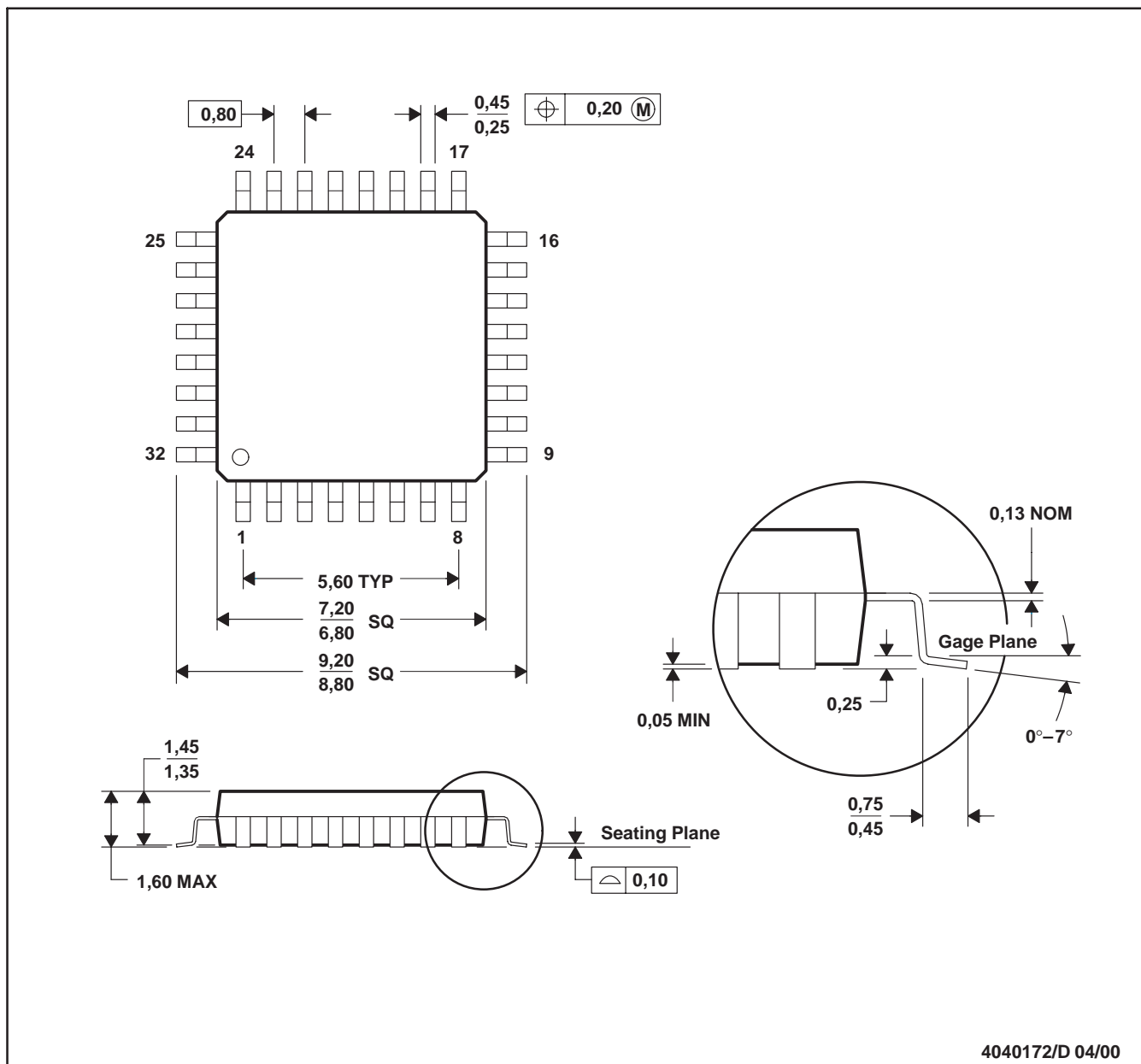

NOTES: A. All linear dimensions are in millimeters.
 B. This drawing is subject to change without notice.

IMPORTANT NOTICE

Texas Instruments Incorporated and its subsidiaries (TI) reserve the right to make corrections, enhancements, improvements and other changes to its semiconductor products and services per JESD46, latest issue, and to discontinue any product or service per JESD48, latest issue. Buyers should obtain the latest relevant information before placing orders and should verify that such information is current and complete. All semiconductor products (also referred to herein as "components") are sold subject to TI's terms and conditions of sale supplied at the time of order acknowledgment.

TI warrants performance of its components to the specifications applicable at the time of sale, in accordance with the warranty in TI's terms and conditions of sale of semiconductor products. Testing and other quality control techniques are used to the extent TI deems necessary to support this warranty. Except where mandated by applicable law, testing of all parameters of each component is not necessarily performed.

TI assumes no liability for applications assistance or the design of Buyers' products. Buyers are responsible for their products and applications using TI components. To minimize the risks associated with Buyers' products and applications, Buyers should provide adequate design and operating safeguards.

TI does not warrant or represent that any license, either express or implied, is granted under any patent right, copyright, mask work right, or other intellectual property right relating to any combination, machine, or process in which TI components or services are used. Information published by TI regarding third-party products or services does not constitute a license to use such products or services or a warranty or endorsement thereof. Use of such information may require a license from a third party under the patents or other intellectual property of the third party, or a license from TI under the patents or other intellectual property of TI.

Reproduction of significant portions of TI information in TI data books or data sheets is permissible only if reproduction is without alteration and is accompanied by all associated warranties, conditions, limitations, and notices. TI is not responsible or liable for such altered documentation. Information of third parties may be subject to additional restrictions.

Resale of TI components or services with statements different from or beyond the parameters stated by TI for that component or service voids all express and any implied warranties for the associated TI component or service and is an unfair and deceptive business practice. TI is not responsible or liable for any such statements.

Buyer acknowledges and agrees that it is solely responsible for compliance with all legal, regulatory and safety-related requirements concerning its products, and any use of TI components in its applications, notwithstanding any applications-related information or support that may be provided by TI. Buyer represents and agrees that it has all the necessary expertise to create and implement safeguards which anticipate dangerous consequences of failures, monitor failures and their consequences, lessen the likelihood of failures that might cause harm and take appropriate remedial actions. Buyer will fully indemnify TI and its representatives against any damages arising out of the use of any TI components in safety-critical applications.

In some cases, TI components may be promoted specifically to facilitate safety-related applications. With such components, TI's goal is to help enable customers to design and create their own end-product solutions that meet applicable functional safety standards and requirements. Nonetheless, such components are subject to these terms.

No TI components are authorized for use in FDA Class III (or similar life-critical medical equipment) unless authorized officers of the parties have executed a special agreement specifically governing such use.

Only those TI components which TI has specifically designated as military grade or "enhanced plastic" are designed and intended for use in military/aerospace applications or environments. Buyer acknowledges and agrees that any military or aerospace use of TI components which have **not** been so designated is solely at the Buyer's risk, and that Buyer is solely responsible for compliance with all legal and regulatory requirements in connection with such use.

TI has specifically designated certain components as meeting ISO/TS16949 requirements, mainly for automotive use. In any case of use of non-designated products, TI will not be responsible for any failure to meet ISO/TS16949.

Products

Audio	www.ti.com/audio
Amplifiers	amplifier.ti.com
Data Converters	dataconverter.ti.com
DLP® Products	www.dlp.com
DSP	dsp.ti.com
Clocks and Timers	www.ti.com/clocks
Interface	interface.ti.com
Logic	logic.ti.com
Power Mgmt	power.ti.com
Microcontrollers	microcontroller.ti.com
RFID	www.ti-rfid.com
OMAP Applications Processors	www.ti.com/omap
Wireless Connectivity	www.ti.com/wirelessconnectivity

Applications

Automotive and Transportation	www.ti.com/automotive
Communications and Telecom	www.ti.com/communications
Computers and Peripherals	www.ti.com/computers
Consumer Electronics	www.ti.com/consumer-apps
Energy and Lighting	www.ti.com/energy
Industrial	www.ti.com/industrial
Medical	www.ti.com/medical
Security	www.ti.com/security
Space, Avionics and Defense	www.ti.com/space-avionics-defense
Video and Imaging	www.ti.com/video

TI E2E Community

e2e.ti.com