



CC2564MODN *Bluetooth*[®] Host Controller Interface (HCI) Module

1 Device Overview

1.1 Features

- Single-Chip Solution Integrating *Bluetooth* Basic Rate (BR)/Enhanced Data Rate (EDR)/Low Energy (LE) Features
- Fully Certified *Bluetooth* 4.1 Module
 - Compliant Up to the HCI Layer
 - FCC ([Z64-2564N](#))/IC ([451I-2564N](#)) Modular Grant with External Chip Antenna (see [Section 6.2.1.3, Antenna](#))
 - CE Certified as Summarized in the [Declaration of Conformity](#)
 - *Bluetooth* 4.1 Controller Subsystem Qualified ([QDID 55257](#))
- BR/EDR Features Include:
 - Up to 7 Active Devices
 - Scatternet: Up to 3 Piconets Simultaneously, 1 as Master and 2 as Slaves
 - Up to 2 SCO Links on the Same Piconet
 - Support for All Voice Air-Coding – Continuously Variable Slope Delta (CVSD), A-Law, μ -Law, and Transparent (Uncoded)
- Assisted Mode for HFP 1.6 Wideband Speech (WBS) Profile or A2DP Profile to Reduce Host Processing and Power
- LE Features Include:
 - Support of Up to 10 Simultaneous Connections
 - Multiple Sniff Instances Tightly Coupled to Achieve Minimum Power Consumption
 - Independent Buffering for LE Allows Large Numbers of Multiple Connections without Affecting BR/EDR Performance.
 - Built-In Coexistence and Prioritization Handling for BR/EDR and LE
- Flexibility for Easy Stack Integration and Validation Into Various Microcontrollers, Such as MSP430™ and ARM[®] Cortex[®]-M3 and Cortex[®]-M4 MCUs
- Highly Optimized for Design into Small Form Factor Systems:
 - Single-Ended 50- Ω RF Interface
 - Module Footprint: 33 Terminals, 0.9-mm Pitch, 7 mm x 7 mm x 1.4 mm
- Best-in-Class *Bluetooth* (RF) Performance (TX Power, RX Sensitivity, Blocking)
 - Class 1.5 TX Power Up to +10 dBm
 - –93 dbm Typical RX Sensitivity
 - Improved Adaptive Frequency Hopping (AFH) Algorithm with Minimum Adaptation Time
 - Provides Longer Range, Including 2x Range Over Other BLE-Only Solutions
- Advanced Power Management for Extended Battery Life and Ease of Design:
 - On-Chip Power Management, Including Direct Connection to Battery
 - Low Power Consumption for Active, Standby, and Scan *Bluetooth* Modes
 - Shutdown and Sleep Modes to Minimize Power Consumption
- Physical Interfaces:
 - UART Transport Layer with Maximum Rate of 4 Mbps
 - Three-Wire UART Transport Layer with Maximum Rate of 4 Mbps
 - Fully Programmable Digital PCM-I2S Codec Interface
- CC256x *Bluetooth* Hardware Evaluation Tool: PC-Based Application to Evaluate RF Performance of the Device and Configure Service Pack
- Lead-Free Design Compliant with RoHS Requirements
- Built-In CC2564B Single-Chip *Bluetooth* Device Fully Compliant with *Bluetooth* and EDR
- Supports Class 1.5 (High-Output Power) Applications
- Small Size with Low Power Consumption
- Supports Maximum *Bluetooth* Data Rates Over HCI UART Interface
- Supports Multiple *Bluetooth* Profiles with Enhanced QoS (Mono and Stereo) Assisted A2DP (No Host Processing Required)

1.2 Applications

- Mobile Accessories
- Sports and Fitness Applications
- Wireless Audio Solutions
- Remote Controls
- Toys



1.3 Description

The CC2564MODN TI *Bluetooth* HCI module is a complete *Bluetooth* BR/EDR/LE HCI solution that reduces design effort and enables fast time to market. Based on TI's seventh-generation *Bluetooth* core, the HCI module provides a product-proven solution that is *Bluetooth* 4.1 compliant. When coupled with a microcontroller unit (MCU), the HCI module provides best-in-class RF performance.

TI's power-management hardware and software algorithms provide significant power savings in all commonly used *Bluetooth* BR/EDR/LE modes of operation.

With transmit power and receive sensitivity, this solution provides a best-in-class range of about 2x, compared to other BLE-only solutions. A royalty-free software *Bluetooth* stack available from TI is pre-integrated with TI's MSP430 and ARM Cortex-M3 and Cortex-M4 MCUs. The stack is also available for made for iPod® (MFi) solutions and on other MCUs through TI's partner [Stonestreet One](#). Some of the profiles supported today include: serial port profile (SPP), advanced audio distribution profile (A2DP), human interface device (HID), and several BLE profiles (these profiles vary based on the supported MCU).

In addition to software, this solution consists of a reference design with a low BOM cost. For more information on TI's wireless platform solutions for *Bluetooth*, see TI's [CC256x wiki](#).

Device Information⁽¹⁾

PART NUMBER	PACKAGE	BODY SIZE
CC2564MODNMOET	MOE (33)	7.1 mm x 7.1 mm
CC2564MODNMOER	MOE (33)	7.1 mm x 7.1 mm

(1) For more information on these devices, see [Section 8, Mechanical, Packaging, and Orderable Information](#)

1.4 Functional Block Diagram

Figure 1-1 shows a functional block diagram of the device.

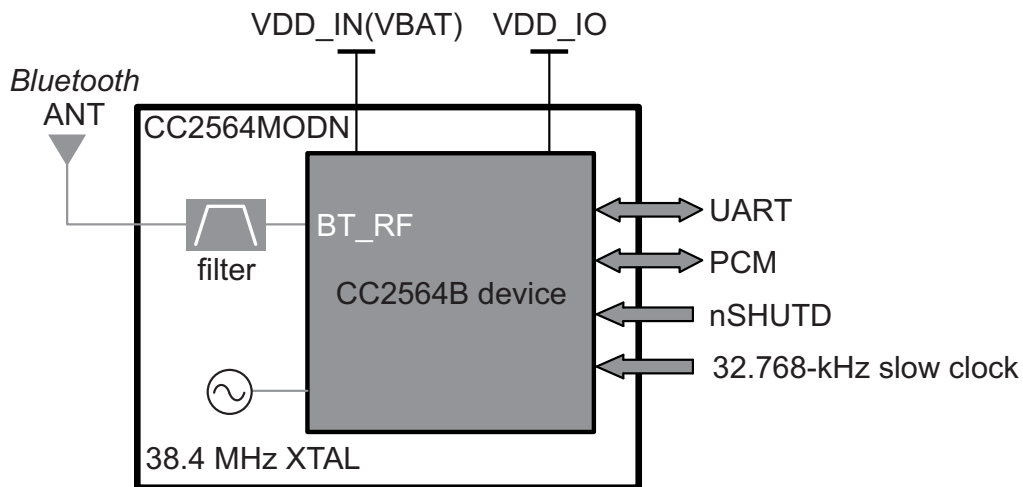

SWRS160-001

Figure 1-1. Functional Block Diagram

Table of Contents

1	Device Overview	<u>1</u>			
	1.1 Features	<u>1</u>		5.4 <i>Bluetooth</i> Transport Layers	<u>18</u>
	1.2 Applications	<u>1</u>		5.5 Host Controller Interface	<u>18</u>
	1.3 Description	<u>2</u>		5.6 Digital Codec Interface	<u>20</u>
	1.4 Functional Block Diagram	<u>2</u>		5.7 Assisted Modes	<u>22</u>
2	Revision History	<u>3</u>	6	Applications, Implementation, and Layout	<u>28</u>
3	Terminal Configuration and Functions	<u>4</u>		6.1 Reference Design Schematics	<u>28</u>
	3.1 Pin Diagram	<u>4</u>		6.2 Layout	<u>28</u>
	3.2 Pin Attributes	<u>5</u>		6.3 Soldering Recommendations	<u>36</u>
4	Specifications	<u>6</u>	7	Device and Documentation Support	<u>37</u>
	4.1 Absolute Maximum Ratings	<u>6</u>		7.1 Device Certification and Qualification	<u>37</u>
	4.2 Handling Ratings	<u>6</u>		7.2 Device Support	<u>37</u>
	4.3 Power-On Hours.....	<u>6</u>		7.3 Community Resources	<u>38</u>
	4.4 Recommended Operating Conditions	<u>6</u>		7.4 Trademarks.....	<u>38</u>
	4.5 Power Consumption Summary	<u>7</u>		7.5 Electrostatic Discharge Caution.....	<u>38</u>
	4.6 Electrical Characteristics	<u>8</u>		7.6 Glossary	<u>38</u>
	4.7 Timing and Switching Characteristics	<u>8</u>	8	Mechanical, Packaging, and Orderable Information	<u>39</u>
5	Detailed Description	<u>17</u>		8.1 Module Outline	<u>39</u>
	5.1 Overview	<u>17</u>		8.2 Mechanical Data	<u>40</u>
	5.2 <i>Bluetooth</i> BR/EDR Description.....	<u>17</u>		8.3 Packaging and Ordering	<u>41</u>
	5.3 <i>Bluetooth</i> LE Description.....	<u>17</u>			

2 Revision History

NOTE: Page numbers for previous revisions may differ from page numbers in the current version.

Changes from Revision A (March 2014) to Revision B	Page
• Changed organizational flow of document in compliance with Data Sheet Council standard	<u>1</u>
• Changed instances of "H4 Protocol – 4-Wire UART" to "UART Transport Layer"	<u>1</u>
• Changed instances of "H5 Protocol – 3-Wire UART" to "Three-Wire UART Transport Layer"	<u>1</u>
• Changed operating ambient temperature range from "-40 to 85" to "-20 to 70" in Section 4.1, Absolute Maximum Ratings	<u>6</u>
• Added minimum values to Section 4.2, Handling Ratings	<u>6</u>
• Added Section 4.3, Power-On Hours	<u>6</u>
• Changed "A3DP source" and "A3DP sink" to "Assisted A2DP source" and "Assisted A2DP sink" in Section 4.5.2.1, Current Consumption for Different Bluetooth BR/EDR Scenarios	<u>7</u>
• Split the "Connected (master and slave role)" cell into two cells in Section 4.5.2.2, Current Consumption for Different LE Scenarios: One for master and one for slave role	<u>8</u>
• Deleted CLK_REQ_OUT and IO1 from Table 4-2	<u>10</u>
• Deleted "25°C, 40°C, 85°C" from the Min, Typ, and Max column headers in Section 4.7.4.1.3, Bluetooth Transmitter—EDR	<u>14</u>
• Changed bitpool range of Assisted A2DP sink from "TBD" to "2-54" in Table 5-10	<u>25</u>
• Changed Section 6.1 title from <i>Reference Design</i>	<u>28</u>
• Changed Reference Schematic	<u>28</u>
• Added Section 6.2, Layout	<u>28</u>
• Added Section 6.3, Soldering Recommendations	<u>36</u>
• Added Section 7.1, Device Certification and Qualification	<u>37</u>
• Added Table 8-3	<u>41</u>

3 Terminal Configuration and Functions

3.1 Pin Diagram

Figure 3-1 shows the top view of the terminal designations.

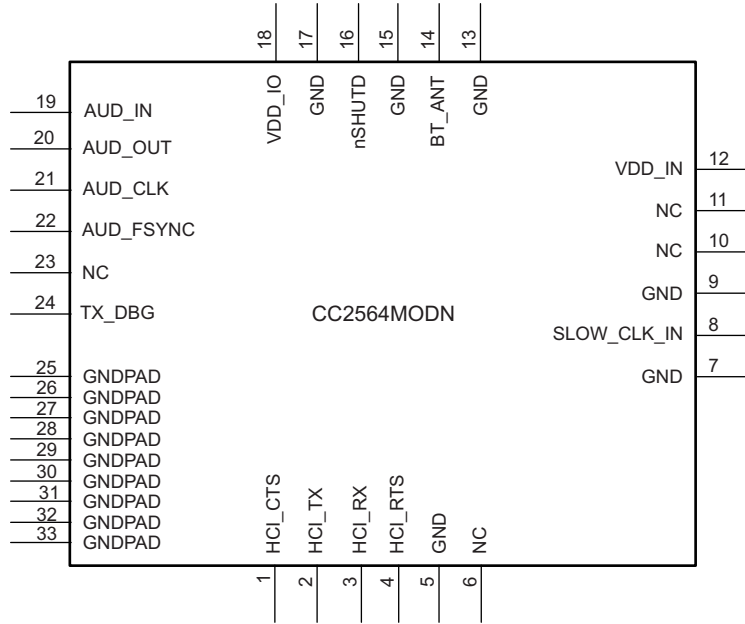

Figure 3-1. Pin Diagram (Top View)

3.2 Pin Attributes

Table 3-1 describes the terminal functions.

Table 3-1. Pin Attributes

Name	No.	ESD ⁽¹⁾ (V)	Pull at Reset	Def. Dir. ⁽²⁾	I/O Type ⁽³⁾	Description
HCI_CTS	1	750	PU	I	8 mA	HCI UART clear-to-send The device can send data when HCI_CTS is low.
HCI_TX	2	750	PU	O	8 mA	HCI UART data transmit
HCI_RX	3	750	PU	I	8 mA	HCI UART data receive
HCI_RTS	4	750	PU	O	8 mA	HCI UART request-to-send Host can send data when HCI_RTS is low.
GND	5	1000				Ground
NC	6			I		Not connected
GND	7	1000				Ground
SLOW_CLK_IN	8	1000		I		32.768-kHz clock in Fail-safe
GND	9	1000				Ground
NC	10			O		Not connected
NC	11			O		Not connected
VDD_IN	12			I		Main power supply for the module
GND	13					Ground
BT_ANT	14	500		IO		<i>Bluetooth</i> RF I/O
GND	15					Ground
nSHUTD	16		PD	I		Shutdown input (active low)
GND	17					Ground
VDD_IO	18	1000		I		I/O power supply (1.8 V nominal)
AUD_IN	19	500	PD	I	4 mA	PCM data input Fail-safe
AUD_OUT	20	500	PD	O	4 mA	PCM data output Fail-safe
AUD_CLK	21	500	PD	I/O	HY, 4 mA	PCM clock Fail-safe
AUD_FSYNC	22	500	PD	I/O	4 mA	PCM frame sync Fail-safe
NC	23	500	PD	I/O	4 mA	Not Connected
TX_DBG	24	1000	PU	O	2 mA	TI internal debug messages. TI recommends leaving a test point.
GNDPAD	25	1000				Ground
GNDPAD	26	1000				Ground
GNDPAD	27	1000				Ground
GNDPAD	28	1000				Ground
GNDPAD	29	1000				Ground
GNDPAD	30	1000				Ground
GNDPAD	31	1000				Ground
GNDPAD	32	1000				Ground
GNDPAD	33	1000				Ground

(1) ESD: Human Body Model (HBM), JEDEC 22-A114 2-wire method. CDM: All pins pass 500 V except RF_IO, which passes 400 V.

(2) I = input; O = output; I/O = bidirectional

(3) I/O Type: Digital I/O cells. HY = input hysteresis, current = typical output current

4 Specifications

Unless otherwise indicated, all measurements are taken at the device pins of the TI test evaluation board (EVB). All specifications are over process, voltage, and temperature, unless otherwise indicated.

4.1 Absolute Maximum Ratings

Over operating free-air temperature range (unless otherwise indicated). All parameters are measured as follows: VDD_IN = 3.6 V and VDD_IO = 1.8 V (unless otherwise indicated).

Parameters ⁽¹⁾		Value	Unit
VDD_IN	Supply voltage range	–0.5 to 4.8	V ⁽²⁾
VDD_IO		–0.5 to 2.145	V
	Input voltage to analog pins ⁽³⁾	–0.5 to 2.1	V
	Input voltage to all other pins	–0.5 to (VDD_IO + 0.5)	V
	Operating ambient temperature range ⁽⁴⁾	–20 to 70	°C
	Bluetooth RF inputs	10	dBm

- (1) Stresses beyond those listed under absolute maximum ratings may cause permanent damage to the device. These are stress ratings only and functional operation of the device at these or any other conditions beyond those indicated under recommended operating conditions is not implied. Exposure to absolute-maximum-rated conditions for extended periods may affect device reliability.
- (2) Maximum allowed depends on accumulated time at that voltage: VDD_IN is defined in [Section 6.1, Reference Design for Power and Radio Connections](#).
- (3) Analog pins: BT_RF, XTALP, and XTALM
- (4) The module supports a temperature range of –20°C to 70°C because of the operating conditions of the crystal.

4.2 Handling Ratings

			MIN	TYP	MAX	UNIT
T _{stg}	Storage temperature range		–55		125	°C
ESD stress voltage ⁽¹⁾	Human body model (HBM) ⁽²⁾	Device	–500		+500	V
	Charged device model (CDM) ⁽³⁾	Device	–500		+500	

- (1) ESD measures device sensitivity and immunity to damage caused by electrostatic discharges into the device.
- (2) The level listed is the passing level per ANSI/ESDA/JEDEC JS-001. JEDEC document JEP155 states that 500-V HBM allows safe manufacturing with a standard ESD control process, and manufacturing with less than 500-V HBM is possible, if necessary precautions are taken. Pins listed as 1000 V can actually have higher performance.
- (3) The level listed is the passing level per EIA-JEDEC JESD22-C101E. JEDEC document JEP157 states that 250-V CDM allows safe manufacturing with a standard ESD control process, and manufacturing with less than 250-V CDM is possible, if necessary precautions are taken. Pins listed as 250 V can actually have higher performance.

4.3 Power-On Hours

Device	Conditions	Power-On Hours
CC2564MODN	Duty Cycle = 25% active and 75% sleep Tambient = 70°C	15,400 Hours (7 Years)

4.4 Recommended Operating Conditions

Rating	Condition	Sym	Min	Max	Unit
Power supply voltage		VDD_IN	2.2	4.8	V
I/O power supply voltage		VDD_IO	1.62	1.92	V
High-level input voltage	Default	V _{IH}	0.65 x VDD_IO	VDD_IO	V
Low-level input voltage	Default	V _{IL}	0	0.35 x VDD_IO	V
I/O input rise and all times, 10% to 90% — asynchronous mode		t _r and t _f	1	10	ns
I/O input rise and fall times, 10% to 90% — synchronous mode (PCM)			1	2.5	ns
Voltage dips on VDD_IN (V _{BAT}) duration = 577 μs to 2.31 ms, period = 4.6 ms				400	mV
Maximum ambient operating temperature ⁽¹⁾			–20	70	°C

- (1) A crystal-based solution is limited by the temperature range required of the crystal to meet 20 ppm.

4.5 Power Consumption Summary

4.5.1 Static Current Consumption

Operational Mode	Min	Typ	Max	Unit
Shutdown mode ⁽¹⁾		1	7	μA
Deep sleep mode ⁽²⁾		40	105	μA
Total I/O current consumption in active mode			1	mA
Continuous transmission—GFSK ⁽³⁾			107	mA
Continuous transmission—EDR ⁽⁴⁾⁽⁵⁾			112.5	mA

(1) $V_{BAT} + V_{IO} + V_{SHUTDOWN}$

(2) $V_{BAT} + V_{IO}$

(3) At maximum output power (10 dBm)

(4) At maximum output power (8 dBm)

(5) Both $\pi/4$ DQPSK and 8DPSK

4.5.2 Dynamic Current Consumption

4.5.2.1 Current Consumption for Different Bluetooth BR/EDR Scenarios

Conditions: VDD_IN = 3.6 V, 25°C, nominal unit, 8-dBm output power

Operational Mode	Master and Slave	Average Current	Unit
Synchronous connection oriented (SCO) link HV3	Master and slave	13.7	mA
Extended SCO (eSCO) link EV3 64 kbps, no retransmission	Master and slave	13.2	mA
eSCO link 2-EV3 64 kbps, no retransmission	Master and slave	10	mA
GFSK full throughput: TX = DH1, RX = DH5	Master and slave	40.5	mA
EDR full throughput: TX = 2-DH1, RX = 2-DH5	Master and slave	41.2	mA
EDR full throughput: TX = 3-DH1, RX = 3-DH5	Master and slave	41.2	mA
Sniff, four attempts, 1.28 seconds	Master and slave	145	μA
Page or inquiry scan 1.28 seconds, 11.25 ms	Master and slave	320	μA
Page (1.28 seconds) and inquiry (2.56 seconds) scans, 11.25 ms	Master and slave	445	μA
A2DP source	Master	13.9	mA
A2DP sink	Master	15.2	mA
Assisted A2DP source	Master	16.9	mA
Assisted A2DP sink	Master	18.1	mA
Assisted WBS EV3; retransmit effort = 2; maximum latency = 8 ms	Master and slave	17.5 and 18.5	mA
Assisted WBS 2EV3; retransmit effort = 2; maximum latency = 12 ms	Master and slave	11.9 and 13	mA

4.5.2.2 Current Consumption for Different LE Scenarios

Conditions: VDD_IN = 3.6 V, 25°C, nominal unit, 8-dBm output power

Mode	Description	Average Current	Unit
Advertising, nonconnectable	Advertising in all three channels 1.28-seconds advertising interval 15 bytes advertise data	114	μA
Advertising, discoverable	Advertising in all three channels 1.28-seconds advertising interval 15 bytes advertise data	138	μA
Scanning	Listening to a single frequency per window 1.28-seconds scan interval 11.25-ms scan window	324	μA
Connected (master role)	500-ms connection interval 0-ms slave connection latency Empty TX and RX LL packets	169 (master)	μA
Connected (slave role)		199 (slave)	

4.6 Electrical Characteristics

Rating		Condition	Min	Max	Unit	
High-level output voltage, V _{OH}		At 2, 4, 8 mA	0.8 x VDD_IO	VDD_IO	V	
		At 0.1 mA	VDD_IO – 0.2	VDD_IO		
Low-level output voltage, V _{OL}		At 2, 4, 8 mA	0	0.2 x VDD_IO	V	
		At 0.1 mA	0	0.2		
I/O input impedance		Resistance	1		MΩ	
		Capacitance		5	pF	
Output rise and fall times, 10% to 90% (digital pins)		C _L = 20 pF		10	ns	
I/O pull currents	PCM-I2S bus, TX_DBG	PU	typ = 6.5	3.5	9.7	μA
		PD	typ = 27	9.5	55	
	All others	PU	typ = 100	50	300	μA
		PD	typ = 100	50	360	

4.7 Timing and Switching Characteristics

4.7.1 Device Power Supply

The power-management hardware and software algorithms of the TI *Bluetooth* HCI module provide significant power savings, which is a critical parameter in an MCU-based system.

The power-management module is optimized for drawing extremely low currents.

4.7.1.1 Power Sources

The TI *Bluetooth* HCI module requires two power sources:

- VDD_IN: main power supply for the module
- VDD_IO: power source for the 1.8-V I/O ring

The HCI module includes several on-chip voltage regulators for increased noise immunity and can be connected directly to the battery.

4.7.1.2 Power Supply Sequencing

The device includes the following power-up requirements (see [Figure 4-1](#)):

- nSHUTD must be low. VDD_IN and VDD_IO are don't-care when nSHUTD is low. However, signals are not allowed on the I/O pins if I/O power is not supplied, because the I/Os are not fail-safe. Exceptions are SLOW_CLK_IN and AUD_XXX, which are fail-safe and can tolerate external voltages with no VDD_IO and VDD_IN.
- VDD_IO and VDD_IN must be stable before releasing nSHUTD.
- The slow clock must be stable within 2 ms of nSHUTD going high.

The device indicates that the power-up sequence is complete by asserting RTS low, which occurs up to 100 ms after nSHUTD goes high. If RTS does not go low, the device is not powered up. In this case, ensure that the sequence and requirements are met.

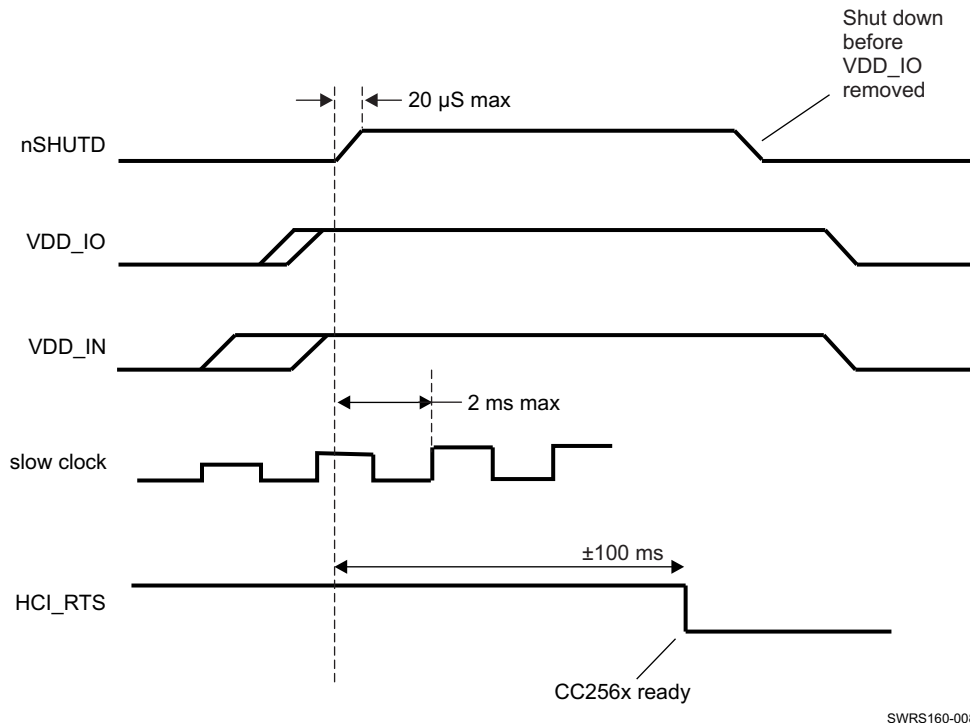

Figure 4-1. Power-Up and Power-Down Sequence

4.7.1.3 Power Supplies and Shutdown – Static States

The nSHUTD signal puts the device in ultra-low power mode and performs an internal reset to the device. The rise time for nSHUTD must not exceed 20 μs; nSHUTD must be low for a minimum of 5 ms.

To prevent conflicts with external signals, all I/O pins are set to the high-impedance (Hi-Z) state during shutdown and power up of the device. The internal pull resistors are enabled on each I/O pin, as described in Section 3.2. Table 4-1 describes the static operation states.

Table 4-1. Power Modes

	VDD_IN ⁽¹⁾	VDD_IO ⁽¹⁾	nSHUTD ⁽¹⁾	PM_MODE	Comments
1	None	None	Asserted	Shut down	I/O state is undefined. No I/O voltages are allowed on nonfail-safe pins.
2	None	None	Deasserted	Not allowed	I/O state is undefined. No I/O voltages are allowed on nonfail-safe pins.
3	None	Present	Asserted	Shut down	I/Os are defined as 3-state with internal pullup or pulldown enabled.

(1) The terms *None* or *Asserted* can imply any of the following conditions: directly pulled to ground or driven low, pulled to ground through a pulldown resistor, or left NC or floating (high-impedance output stage).

Table 4-1. Power Modes (continued)

	VDD_IN ⁽¹⁾	VDD_IO ⁽¹⁾	nSHUTD ⁽¹⁾	PM_MODE	Comments
4	None	Present	Deasserted	Not allowed	I/O state is undefined. No I/O voltages are allowed on nonfail-safe pins.
5	Present	None	Asserted	Shut down	I/O state is undefined.
6	Present	None	Deasserted	Not allowed	I/O state is undefined. No I/O voltages are allowed on nonfail-safe pins.
7	Present	Present	Asserted	Shut down	I/Os are defined as 3-state with internal pullup or pulldown enabled.
8	Present	Present	Deasserted	Active	See Section 4.7.1.4, <i>I/O States in Various Power Modes</i>

4.7.1.4 I/O States in Various Power Modes**CAUTION**

Some device I/Os are not fail-safe (see Section 3.2, Pin Attributes). Fail-safe means that the pins do not draw current from an external voltage applied to the pin when I/O power is not supplied to the device. External voltages are not allowed on these I/O pins when the I/O supply voltage is not supplied because of possible damage to the device.

Table 4-2 lists the I/O states in various power modes.

Table 4-2. I/O States in Various Power Modes

I/O Name	Shut Down ⁽¹⁾		Default Active ⁽¹⁾		Deep Sleep ⁽¹⁾	
	I/O State	Pull	I/O State	Pull	I/O State	Pull
HCI_RX	Z	PU	I	PU	I	PU
HCI_TX	Z	PU	O-H	–	O	–
HCI_RTS	Z	PU	O-H	–	O	–
HCI_CTS	Z	PU	I	PU	I	PU
AUD_CLK	Z	PD	I	PD	I	PD
AUD_FSYNC	Z	PD	I	PD	I	PD
AUD_IN	Z	PD	I	PD	I	PD
AUD_OUT	Z	PD	Z	PD	Z	PD
TX_DBG	Z	PU	O	–		

(1) I = input, O = output, Z = Hi-Z, – = no pull, PU = pullup, PD = pulldown, H = high, L = low

4.7.1.5 nSHUTD Requirements

Parameter	Sym	Min	Max	Unit
Operation mode level ⁽¹⁾	V _{IH}	1.42	1.98	V
Shutdown mode level ⁽¹⁾	V _{IL}	0	0.4	V
Minimum time for nSHUT_DOWN low to reset the device		5		ms
Rise and fall times	t _r and t _f		20	µs

(1) An internal 300-kΩ pulldown retains shut-down mode when no external signal is applied to this pin.

4.7.2 Clock Specifications

4.7.2.1 Slow Clock

An external source must supply the slow clock and connect to the SLOW_CLK_IN pin. The source must be a digital signal in the range of 0 to 1.8 V. The accuracy of the slow clock frequency must be 32.768 kHz \pm 250 ppm for *Bluetooth* use (as specified in the *Bluetooth* specification). The external slow clock must be stable within 64 slow-clock cycles (2 ms) following the release of nSHUTD.

4.7.2.2 Slow Clock Requirements

Characteristics	Condition	Sym	Min	Typ	Max	Unit
Input slow clock frequency				32768		Hz
Input slow clock accuracy (Initial + temp + aging)	<i>Bluetooth</i>				\pm 250	ppm
	ANT				\pm 50	
Input transition time t_r and t_f (10% to 90%)		t_r and t_f			200	ns
Frequency input duty cycle			15%	50%	85%	
Slow clock input voltage limits	Square wave, DC-coupled	V_{IH}	$0.65 \times V_{DD_IO}$		V_{DD_IO}	V peak
		V_{IL}	0		$0.35 \times V_{DD_IO}$	V peak
Input impedance			1			M Ω
Input capacitance					5	pF

4.7.3 Peripherals

4.7.3.1 UART

Figure 4-2 shows the UART timing diagram.

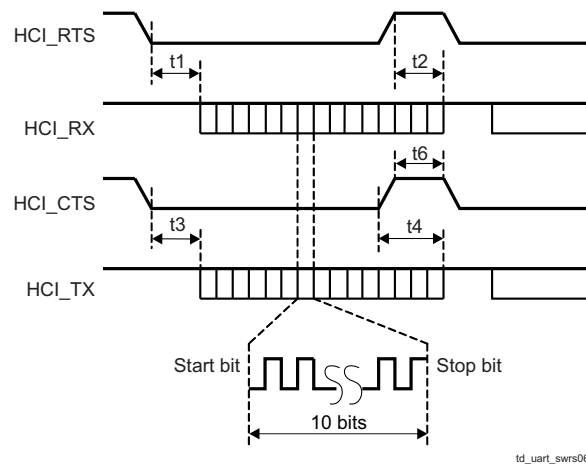

Figure 4-2. UART Timing

Table 4-3 lists the UART timing characteristics.

Table 4-3. UART Timing Characteristics

Symbol	Characteristics	Condition	Min	Typ	Max	Unit
	Baud rate		37.5		4000	kbps
	Baud rate accuracy per byte	Receive and transmit	-2.5		1.5	%
	Baud rate accuracy per bit	Receive and transmit	-12.5		12.5	%
t3	CTS low to TX_DATA on		0	2		μs
t4	CTS high to TX_DATA off	Hardware flow control			1	byte
t6	CTS-high pulse width		1			bit
t1	RTS low to RX_DATA on		0	2		μs
t2	RTS high to RX_DATA off	Interrupt set to 1/4 FIFO			16	byte

Figure 4-3 shows the UART data frame.

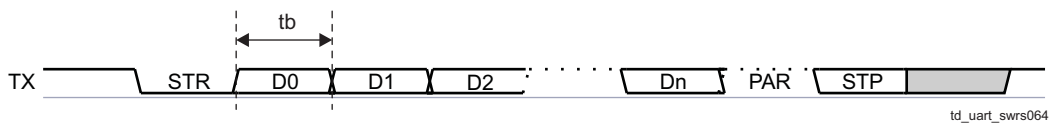

Figure 4-3. Data Frame

Table 4-4 describes the symbols used in Figure 4-3.

Table 4-4. Data Frame Key

Symbol	Description
STR	Start bit
D0...Dn	Data bits (LSB first)
PAR	Parity bit (optional)
STP	Stop bit

4.7.3.2 PCM

Figure 4-4 shows the interface timing for the PCM.

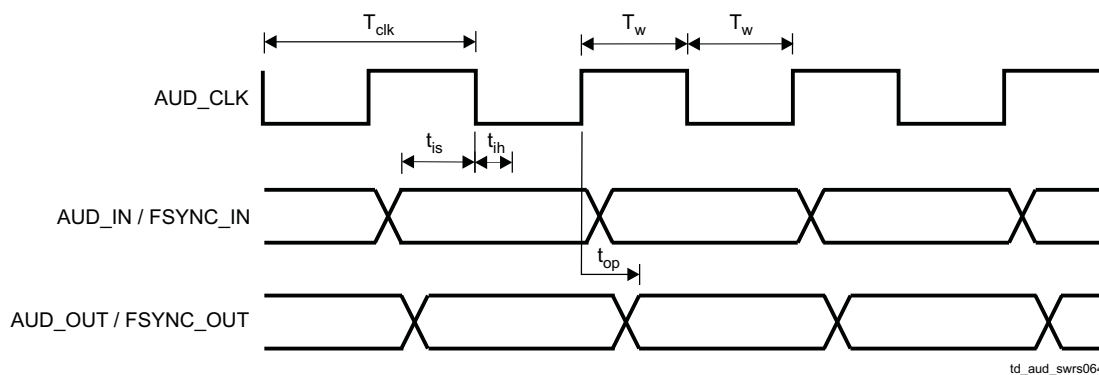

Figure 4-4. PCM Interface Timing

Table 4-5 lists the associated PCM master parameters.

Table 4-5. PCM Master

Symbol	Parameter	Condition	Min	Max	Unit
T_{clk}	Cycle time		244.14 (4.096 MHz)	15625 (64 kHz)	ns
T_w	High or low pulse width		50% of T_{clk} min		
t_{is}	AUD_IN setup time		25		
t_{ih}	AUD_IN hold time		0		
t_{op}	AUD_OUT propagation time	40-pF load	0	10	
t_{op}	FSYNC_OUT propagation time	40-pF load	0	10	

Table 4-6 lists the associated PCM slave parameters.

Table 4-6. PCM Slave

Symbol	Parameter	Condition	Min	Max	Unit
T_{clk}	Cycle time		66.67 (15 MHz)		ns
T_w	High or low pulse width		40% of T_{clk}		
T_{is}	AUD_IN setup time		8		
T_{ih}	AUD_IN hold time		0		
t_{is}	AUD_FSYNC setup time		8		
t_{ih}	AUD_FSYNC hold time		0		
t_{op}	AUD_OUT propagation time	40-pF load	0	21	

4.7.4 RF Performance

4.7.4.1 Bluetooth BR/EDR RF Performance

All parameters in this section that are fast-clock dependent are verified using a 38.4-MHz XTAL and an RF load of 50 Ω at the BT_RF port.

4.7.4.1.1 Bluetooth Receiver—In-Band Signals

Characteristics	Condition	Min	Typ	Max	Bluetooth Specification	Unit
Operation frequency range		2402		2480		MHz
Channel spacing			1			MHz
Input impedance			50			Ω
Sensitivity, dirty TX on ⁽¹⁾	GFSK, BER = 0.1%		-93		-70	dBm
	Pi/4-DQPSK, BER = 0.01%		-92.5		-70	
	8DPSK, BER = 0.01%		-85.5		-70	
BER error floor at sensitivity + 10 dB, dirty TX off	Pi/4-DQPSK		1E-7		1E-5	
	8DPSK				1E-5	
Maximum usable input power	GFSK, BER = 0.1%	-5			-20	dBm
	Pi/4-DQPSK, BER = 0.1%	-10				
	8DPSK, BER = 0.1%	-10				
Intermodulation characteristics	Level of interferers (for n = 3, 4, and 5)		-30		-39	dBm

(1) Sensitivity degradation up to 3 dB may occur for minimum and typical values where the Bluetooth frequency is a harmonic of the fast clock.

Characteristics	Condition		Min	Typ	Max	Bluetooth Specification	Unit
C/I performance ⁽²⁾ Image = -1 MHz	GFSK, co-channel			8		11	dB
	EDR, co-channel	Pi/4-DQPSK		9.5		13	
		8DPSK		16.5		21	
	GFSK, adjacent ±1 MHz			-10		0	
	EDR, adjacent ±1 MHz, (image)	Pi/4-DQPSK		-10		0	
		8DPSK		-5		5	
	GFSK, adjacent +2 MHz			-38		-30	
	EDR, adjacent, +2 MHz	Pi/4-DQPSK		-38		-30	
		8DPSK		-38		-25	
	GFSK, adjacent -2 MHz			-28		-20	
	EDR, adjacent -2 MHz	Pi/4-DQPSK		-28		-20	
		8DPSK		-22		-13	
GFSK, adjacent ≥ ±3 MHz			-45		-40		
EDR, adjacent ≥ ±3 MHz	Pi/4-DQPSK		-45		-40		
	8DPSK		-44		-33		
RF return loss				-10			dB
RX mode LO leakage	Fr _f = (received RF - 0.6 MHz)			-63			dBm

(2) Numbers show ratio of desired signal to interfering signal. Smaller numbers indicate better C/I performance.

4.7.4.1.2 Bluetooth Transmitter—GFSK

Characteristics	Min	Typ	Max	Bluetooth Specification	Unit
Maximum RF output power ⁽¹⁾		10			dBm
Gain control range		30			dB
Power control step	2		8	2 to 8	
Adjacent channel power M-N = 2		-45		≤ -20	dBm
Adjacent channel power M-N > 2		-50		≤ -40	

(1) To modify maximum output power, use an HCI VS command.

4.7.4.1.3 Bluetooth Transmitter—EDR

Characteristics		Min	Typ	Max	Bluetooth Specification	Unit
EDR output power	Pi/4-DQPSK	VDD_IN = V _{BAT}	8			dBm
	8DPSK	VDD_IN = V _{BAT}	8			
EDR relative power		-2		1	-4 to +1	dB
Gain control range			30			
Power control step		2		8	2 to 8	
Adjacent channel power M-N = 1			-30		≤ -26	dBc
Adjacent channel power M-N = 2			-27		≤ -20	dBm
Adjacent channel power M-N > 2 ⁽¹⁾			-42		≤ -40	dBm

(1) Adjacent channel power measurements take into account specification exception of three bands, as defined by the *Test Suite Structure (TSS) and Test Purposes (TP) Bluetooth Documentation Specification*.

4.7.4.1.4 Bluetooth Modulation—GFSK

Characteristics	Condition		Sym	Min	Typ	Max	Bluetooth Specification	Unit
-20 dB bandwidth	GFSK				925		≤ 1000	kHz
Modulation characteristics	Δf1avg	Mod data = 4 1 s, 4 0 s: 111100001111...	F1 avg		165		140 to 175	kHz
	Δf2max ≥ limit for at least 99.9% of all Δf2max	Mod data = 1010101...	F2 max		130		> 115	kHz
	Δf2avg, Δf1avg				88		> 80	%
Absolute carrier frequency drift	DH1			-25		25	< ±25	kHz
	DH3 and DH5			-35		35	< ±40	
Drift rate						20	< 20	kHz/ 50 μs
Initial carrier frequency tolerance	f0 – fTX			-75		+75	< ±75	kHz

4.7.4.1.5 Bluetooth Modulation—EDR

Characteristics	Condition	Min	Typ	Max	Bluetooth Specification	Unit
Carrier frequency stability		-10		10	≤ 10	kHz
Initial carrier frequency tolerance		-75		75	±75	kHz
Rms DEVM ⁽¹⁾	Pi/4-DQPSK		6		20	%
	8DPSK		6		13	
99% DEVM ⁽¹⁾	Pi/4-DQPSK			30	30	
	8DPSK			20	20	
Peak DEVM ⁽¹⁾	Pi/4-DQPSK		14		35	
	8DPSK		16		25	

(1) Max performance refers to maximum TX power.

4.7.4.2 Bluetooth LE RF Performance

All parameters in this section that are fast-clock dependent are verified using a 38.4-MHz XTAL and an RF load of 50 Ω at the BT_RF port.

4.7.4.2.1 BLE Receiver—In-Band Signals

Characteristic	Condition	Min	Typ	Max	BLE Specification	Unit
Operation frequency range		2402		2480		MHz
Channel spacing			2			MHz
Input impedance			50			Ω
Sensitivity, dirty TX on ⁽¹⁾	PER = 30.8%; dirty TX on		-93		≤ -70	dBm
Maximum usable input power	GMSK, PER = 30.8%	-10			≥ -10	dBm
Intermodulation characteristics	Level of interferers (for n = 3, 4, 5)		-30		≥ -50	dBm

(1) Sensitivity degradation up to 3 dB may occur where the BLE frequency is a harmonic of the fast clock.

Characteristic	Condition	Min	Typ	Max	BLE Specification	Unit
C/I performance ⁽²⁾ Image = -1 MHz	GMSK, co-channel		8		≤ 21	dB
	GMSK, adjacent ±1 MHz		-5		≤ 15	
	GMSK, adjacent +2 MHz		-45		≤ -17	
	GMSK, adjacent -2 MHz		-22		≤ -15	
	GMSK, adjacent ≥ ±3 MHz		-47		≤ -27	
RX mode LO leakage	Fr _f = (received RF - 0.6 MHz)		-63			dBm

(2) Numbers show wanted signal-to-interfering signal ratio. Smaller numbers indicate better C/I performance.

4.7.4.2.2 BLE Transmitter

Characteristics	Min	Typ	Max	BLE Specification	Unit
RF output power (VDD_IN = VBAT) ⁽¹⁾		10 ⁽²⁾		≤ 10	dBm
Adjacent channel power M-N = 2		-45		≤ -20	dBm
Adjacent channel power M-N > 2		-50		≤ -30	

(1) To modify maximum output power, use an HCI VS command.

(2) To achieve the BLE specification of 10-dBm maximum, an insertion loss of > 2 dB is assumed between the RF ball and the antenna. Otherwise, use an HCI VS command to modify the output power.

4.7.4.2.3 BLE Modulation

Characteristics	Condition		Sym	Min	Typ	Max	BLE Specification	Unit
Modulation characteristics	Δf1avg	Mod data = 4 1s, 4 0 s: 1111000011110000. ..	Δf1 avg		250		225 to 275	kHz
	Δf2max ≥ limit for at least 99.9% of all Δf2max	Mod data = 1010101...	Δf2 max		210		≥ 185	
	Δf2avg, Δf1avg				0.9		≥ 0.8	
Absolute carrier frequency drift				-25		25	≤ ±50	kHz
Drift rate						15	≤ 20	kHz/50 ms
Initial carrier frequency tolerance				-25		25	≤ ±100	kHz

5 Detailed Description

5.1 Overview

Table 5-1. Technology and Assisted Modes Supported

Module	Description	Technology Supported			Assisted Modes Supported	
		BR/EDR	LE	ANT	HFP 1.6 (WBS)	A2DP
CC2564MODN	Bluetooth 4.1 + BLE	√	√		√	√
	Bluetooth 4.1 + ANT	√		√	√	√

5.2 Bluetooth BR/EDR Description

The TI *Bluetooth* HCI module is *Bluetooth* 4.1 compliant up to the HCI level (for the technology supported, see [Table 5-1](#)):

- Up to seven active devices
- Scatternet: Up to 3 piconets simultaneously, 1 as master and 2 as slaves
- Up to two synchronous connection oriented (SCO) links on the same piconet
- Very fast AFH algorithm for asynchronous connection-oriented link (ACL) and extended SCO (eSCO) link
- Supports typically 10-dBm TX power without an external power amplifier (PA), thus improving *Bluetooth* link robustness
- Digital radio processor (DRP™) single-ended 50-Ω I/O for easy RF interfacing
- Internal temperature detection and compensation to ensure minimal variation in RF performance over temperature
- Flexible pulse-code modulation (PCM) and inter-IC sound (I2S) digital codec interface:
 - Full flexibility of data format (linear, A-Law, μ -Law)
 - Data width
 - Data order
 - Sampling
 - Slot positioning
 - Master and slave modes
 - High clock rates up to 15 MHz for slave mode (or 4.096 MHz for master mode)
- Support for all voice air-coding
 - CVSD
 - A-Law
 - μ -Law
 - Transparent (uncoded)

5.3 Bluetooth LE Description

- *Bluetooth* 4.1 compliant
- Solution optimized for proximity and sports use cases
- Supports up to 10 (CC2564 or CC2564B) simultaneous connections
- Multiple sniff instances that are tightly coupled to achieve minimum power consumption
- Independent buffering for LE, allowing large numbers of multiple connections without affecting BR/EDR performance.
- Includes built-in coexistence and prioritization handling for BR/EDR and LE

NOTE

ANT and the assisted modes (HFP 1.6 and A2DP) are not available when BLE is enabled.

5.4 Bluetooth Transport Layers

Figure 5-1 shows the *Bluetooth* transport layers.

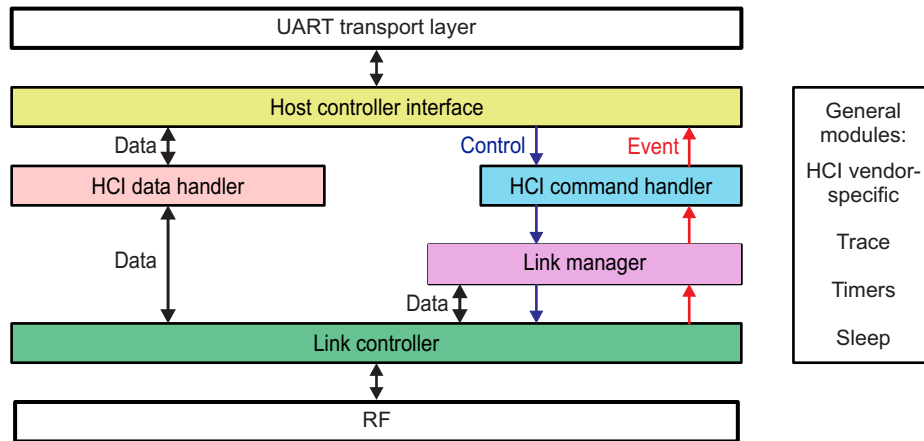

SWRS121-016

Figure 5-1. Bluetooth Transport Layers

5.5 Host Controller Interface

The TI *Bluetooth* HCI module incorporates one UART module dedicated to the HCI transport layer. The HCI interface transports commands, events, and ACL between the device and the host using HCI data packets.

The maximum baud rate of the UART module is 4 Mbps; however, the default baud rate after power up is set to 115.2 kbps. The baud rate can thereafter be changed with a VS command. The device responds with a command complete event (still at 115.2 kbps), after which the baud rate change occurs.

The UART module includes the following features:

- Receiver detection of break, idle, framing, FIFO overflow, and parity error conditions
- Transmitter underflow detection
- CTS and RTS hardware flow control (UART transport layer)
- XON and XOFF software flow control (Three-wire UART transport layer)

Table 5-2 lists the UART module default settings.

Table 5-2. UART Module Default Settings

Parameter	Value
Bit rate	115.2 kbps
Data length	8 bits
Stop bit	1
Parity	None

5.5.1 UART Transport Layer

The UART Transport Layer includes four signals:

- TX
- RX
- CTS
- RTS

Flow control between the host and the TI *Bluetooth* HCI module is byte-wise by hardware.

Figure 5-2 shows the H4 UART interface.

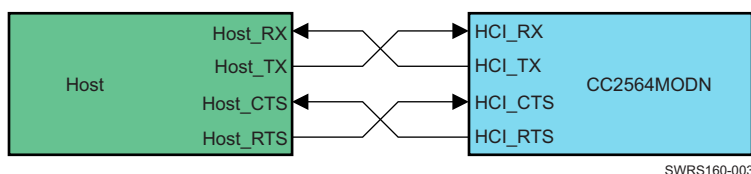

Figure 5-2. UART Transport Layer

When the UART RX buffer of the TI *Bluetooth* HCI module passes the flow control threshold, it sets the HCI_RTS signal high to stop transmission from the host.

When the HCI_CTS signal is set high, the module stops transmission on the interface. If HCI_CTS is set high while transmitting a byte, the module finishes transmitting the byte and stops the transmission.

The UART Transport Layer includes a mechanism that handles the transition between active mode and sleep mode. The protocol occurs through the CTS and RTS UART lines and is known as the enhanced HCI low level (eHCILL) power-management protocol.

For more information on the UART Transport Layer, see Part A, UART Transport Layer, found in [Volume 4: HCI Transports](#) of the [Adopted Bluetooth Core Specifications](#).

5.5.2 Three-Wire UART Transport Layer

The Three-Wire UART Transport Layer consists of three signals (see Figure 5-3).

- TX
- RX
- GND

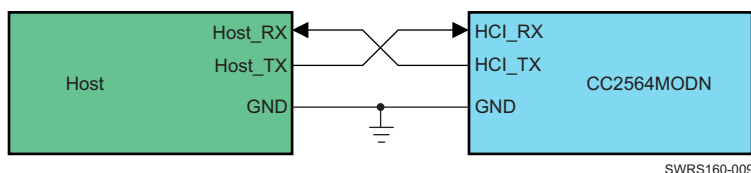

Figure 5-3. Three-Wire UART Transport Layer

The Three-Wire UART Transport Layer supports the following features:

- Software flow control (XON/XOFF)
- Power management using the software messages:
 - WAKEUP
 - WOKEN
 - SLEEP
- CRC data integrity check

For more information on the Three-Wire UART Transport Layer, see Part D: Three-Wire UART Transport Layer, found in [Volume 4: HCI Transports](#) of the [Adopted Bluetooth Core Specifications](#).

5.6 Digital Codec Interface

The codec interface is a fully programmable port to support seamless interfacing with different PCM and I2S codec devices. The interface includes the following features:

- Two voice channels
- Master and slave modes
- All voice coding schemes defined by the *Bluetooth* specification: linear, A-Law, and μ -Law
- Long and short frames
- Different data sizes, order, and positions
- High flexibility to support a variety of codecs
- Bus sharing: Data_Out is in Hi-Z state when the interface is not transmitting voice data.

5.6.1 Hardware Interface

The interface includes four signals:

- Clock: configurable direction (input or output)
- Frame_Sync and Word_Sync: configurable direction (input or output)
- Data_In: input
- Data_Out: output or 3-state

The module can be the master of the interface when generating the Clock and Frame_Sync signals or the slave when receiving these two signals.

For slave mode, clock input frequencies of up to 15 MHz are supported. At clock rates above 12 MHz, the maximum data burst size is 32 bits.

For master mode, the module can generate any clock frequency between 64 kHz and 4.096 MHz.

5.6.2 I2S

When the codec interface is configured to support the I2S protocol, these settings are recommended:

- Bidirectional, full-duplex interface
- Two time slots per frame: time slot-0 for the left channel audio data; and time slot-1 for the right channel audio data
- Each time slot is configurable up to 40 serial clock cycles long, and the frame is configurable up to 80 serial clock cycles long.

5.6.3 Data Format

The data format is fully configurable:

- The data length can be from 8 to 320 bits in 1-bit increments when working with 2 channels, or up to 640 bits when working with 1 channel. The data length can be set independently for each channel.
- The data position within a frame is also configurable within 1 clock (bit) resolution and can be set independently (relative to the edge of the Frame_Sync signal) for each channel.
- The Data_In and Data_Out bit order can be configured independently. For example, Data_In can start with the most significant bit (MSB); Data_Out can start with the least significant bit (LSB). Each channel is separately configurable. The inverse bit order (that is, LSB first) is supported only for sample sizes up to 24 bits.
- Data_In and Data_Out are not required to be the same length.
- The Data_Out line is configured to Hi-Z output between data words. Data_Out can also be set for permanent Hi-Z, regardless of the data output. This configuration allows the module to be a bus slave in a multislave PCM environment. At power up, Data_Out is configured as Hi-Z.

5.6.4 Frame Idle Period

The codec interface handles frame idle periods, in which the clock pauses and becomes 0 at the end of the frame, after all data are transferred.

The module supports frame idle periods both as master and slave of the codec bus.

When the module is the master of the interface, the frame idle period is configurable. There are two configurable parameters:

- Clk_Idle_Start: indicates the number of clock cycles from the beginning of the frame to the beginning of the idle period. After Clk_Idle_Start clock cycles, the clock becomes 0.
- Clk_Idle_End: indicates the time from the beginning of the frame to the end of the idle period. The time is given in multiples of clock periods.

The delta between Clk_Idle_Start and Clk_Idle_End is the clock idle period.

For example, for clock rate = 1 MHz, frame sync period = 10 kHz, Clk_Idle_Start = 60, Clk_Idle_End = 90.

Between both Frame_Sync signals there are 70 clock cycles (instead of 100). The clock idle period starts 60 clock cycles after the beginning of the frame and lasts 90 – 60 = 30 clock cycles. Thus, the idle period ends 100 – 90 = 10 clock cycles before the end of the frame. The data transmission must end before the beginning of the idle period.

Figure 5-4 shows the frame idle timing.

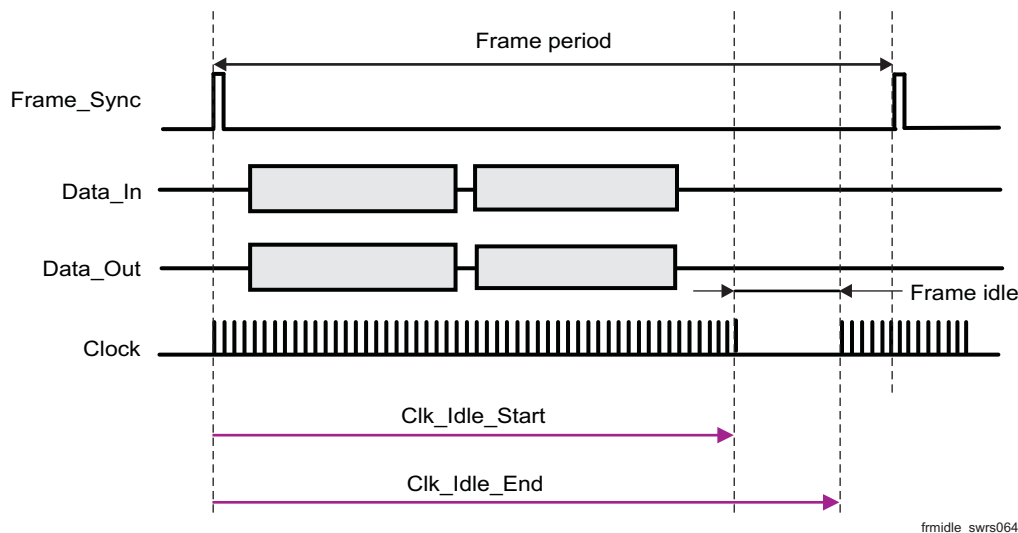

Figure 5-4. Frame Idle Period

5.6.5 Clock-Edge Operation

The codec interface of the module can work on the rising or the falling edge of the clock and can sample the Frame_Sync signal and the data at inversed polarity.

Figure 5-5 shows the operation of a falling-edge-clock type of codec. The codec is the master of the bus. The Frame_Sync signal is updated (by the codec) on the falling edge of the clock and is therefore sampled (by the module) on the next rising clock. The data from the codec is sampled (by the module) on the falling edge of the clock

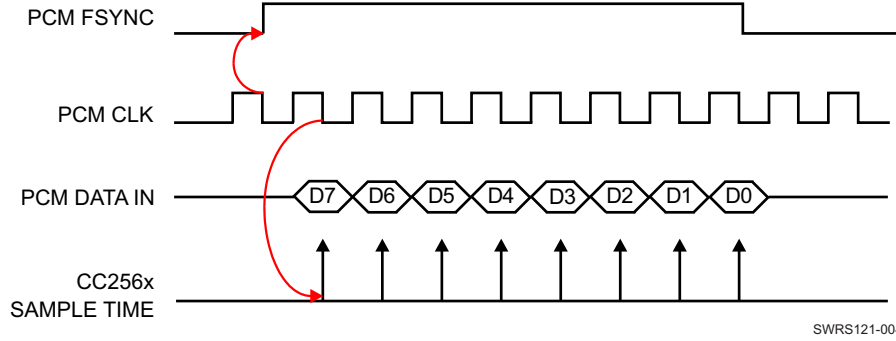

Figure 5-5. Negative Clock Edge Operation

5.6.6 Two-Channel Bus Example

Figure 5-6 shows a 2-channel bus in which the two channels have different word sizes and arbitrary positions in the bus frame. (FT stands for frame timer.)

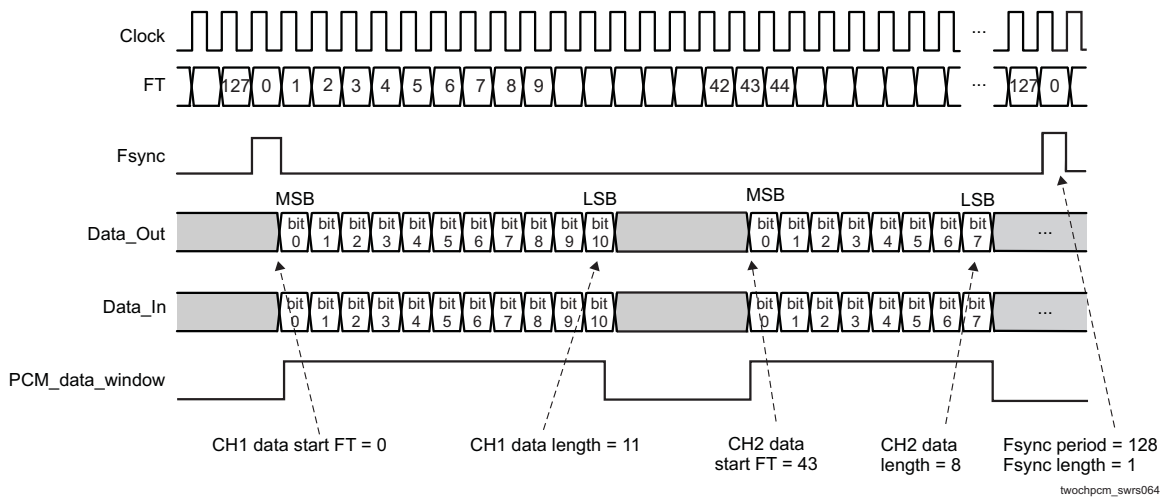

Figure 5-6. 2-Channel Bus Timing

5.7 Assisted Modes

The TI *Bluetooth* HCI module contains an embedded coprocessor that can be used for multiple purposes. The module uses the coprocessor to perform the LE or ANT functionality. The module also uses the coprocessor to execute the assisted HFP 1.6 (WBS) or assisted A2DP functions. Only one of these functions can be executed at a time because they all use the same resources (that is, the coprocessor; see Table 5-1 for the modes of operation supported by the module).

This section describes the assisted HFP 1.6 (WBS) and assisted A2DP modes of operation in the module. These modes of operation minimize host processing and power by taking advantage of the device coprocessor to perform the voice and audio SBC processing required in HFP 1.6 (WBS) and A2DP profiles. This section also compares the architecture of the assisted modes with the common implementation of the HFP 1.6 and A2DP profiles.

The assisted HFP 1.6 (WBS) and assisted A2DP modes of operation comply fully with the HFP 1.6 and A2DP *Bluetooth* specifications. For more information on these profiles, see the corresponding *Bluetooth* profile specification in [Adopted Bluetooth Core Specifications](#).

5.7.1 Assisted HFP 1.6 (WBS)

The HFP 1.6 Profile Specification adds the requirement for WBS support. The WBS feature allows twice the voice quality versus legacy voice coding schemes at the same air bandwidth (64 kbps). This feature is achieved using a voice sampling rate of 16 kHz, a modified subband coding (mSBC) scheme, and a packet loss concealment (PLC) algorithm. The mSBC scheme is a modified version of the mandatory audio coding scheme used in the A2DP profile with the parameters listed in [Table 5-3](#).

Table 5-3. mSBC Parameters

Parameter	Value
Channel mode	Mono
Sampling rate	16 kHz
Allocation method	Loudness
Subbands	8
Block length	15
Bitpool	26

The assisted HFP 1.6 mode of operation implements this WBS feature on the embedded coprocessor. That is, the mSBC voice coding scheme and the PLC algorithm are executed in the coprocessor rather than in the host, thus minimizing host processing and power. One WBS connection at a time is supported and WBS and NBS connections cannot be used simultaneously in this mode of operation. [Figure 5-7](#) shows the architecture comparison between the common implementation of the HFP 1.6 profile and the assisted HFP 1.6 solution.

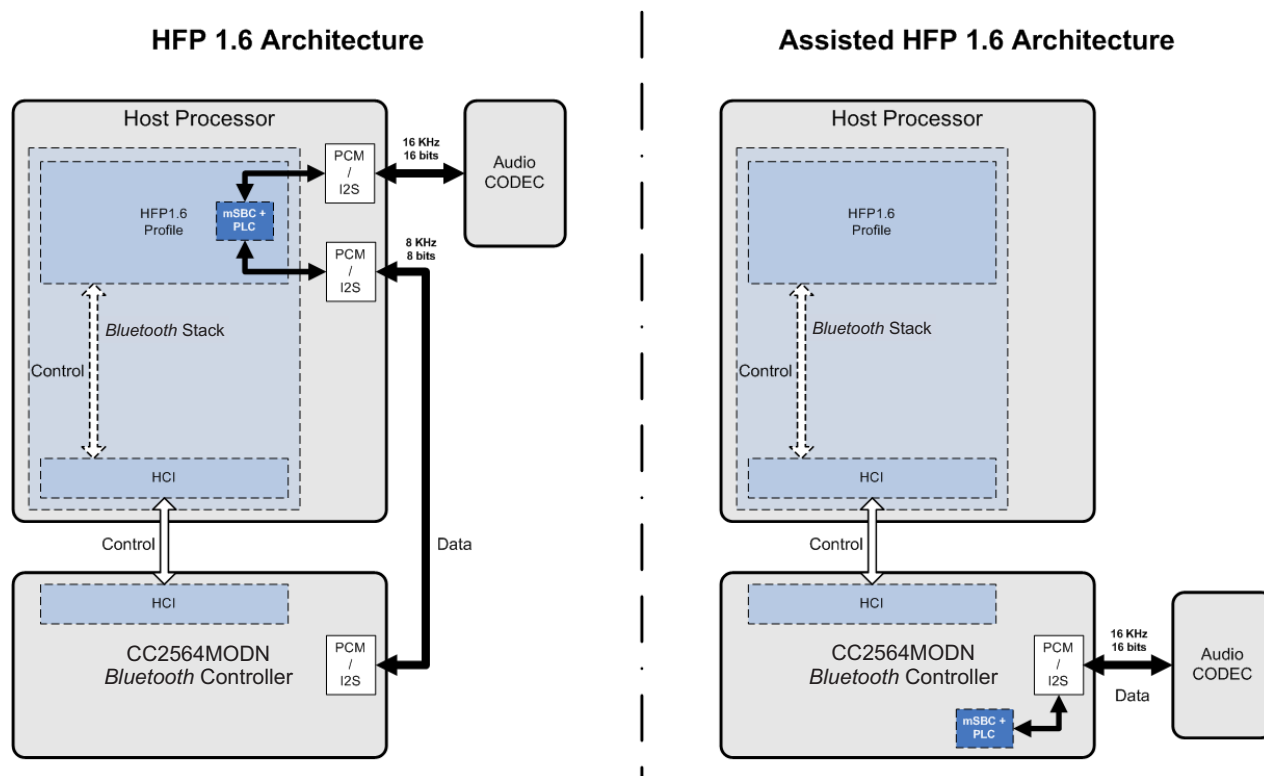

Figure 5-7. HFP 1.6 Architecture Versus Assisted HFP 1.6 Architecture

5.7.2 Assisted A2DP

The A2DP enables wireless transmission of high-quality mono or stereo audio between two devices. A2DP defines two roles:

- A2DP source is the transmitter of the audio stream.
- A2DP sink is the receiver of the audio stream.

A typical use case streams music from a tablet, phone, or PC (the A2DP source) to headphones or speakers (the A2DP sink). This section describes the architecture of these roles and compares them with the corresponding assisted-A2DP architecture. To use the air bandwidth efficiently, the audio data must be compressed in a proper format. The A2DP mandates support of the SBC scheme. Other audio coding algorithms can be used; however, both *Bluetooth* devices must support the same coding scheme. SBC is the only coding scheme spread out in all A2DP *Bluetooth* devices, and thus the only coding scheme supported in the assisted A2DP modes. [Table 5-4](#) lists the recommended parameters for the SBC scheme in the assisted A2DP modes.

Table 5-4. Recommended Parameters for the SBC Scheme in Assisted A2DP Modes

SBC Encoder Settings ⁽¹⁾	Mid Quality				High Quality			
	Mono		Joint Stereo		Mono		Joint Stereo	
Sampling frequency (kHz)	44.1	48	44.1	48	44.1	48	44.1	48
Bitpool value	19	18	35	33	31	29	53	51
Resulting frame length (bytes)	46	44	83	79	70	66	119	115
Resulting bit rate (Kbps)	127	132	229	237	193	198	328	345

(1) Other settings: Block length = 16; allocation method = loudness; subbands = 8.

The SBC scheme supports a wide variety of configurations to adjust the audio quality. [Table 5-5](#) through [Table 5-12](#) list the supported SBC capabilities in the assisted A2DP modes.

Table 5-5. Channel Modes

Channel Mode	Status
Mono	Supported
Stereo	Supported
Joint stereo	Supported

Table 5-6. Sampling Frequency

Sampling Frequency (kHz)	Status
16	Supported
44.1	Supported
48	Supported

Table 5-7. Block Length

Block Length	Status
16	Supported

Table 5-8. Subbands

Subbands	Status
8	Supported

Table 5-9. Allocation Method

Allocation Method	Status
Loudness	Supported

Table 5-10. Bitpool Values

Bitpool Range	Status
Assisted A2DP sink: 2-54	Supported
Assisted A2DP source: 2-54	Supported

Table 5-11. L2CAP MTU Size

L2CAP MTU Size (Bytes)	Status
Assisted A2DP sink: 260-800	Supported
Assisted A2DP source: 260-1021	Supported

Table 5-12. Miscellaneous Parameters

Item	Value	Status
A2DP content protection	Protected	Not supported
AVDTP service	Basic type	Supported
L2CAP mode	Basic mode	Supported
L2CAP flush	Nonflushable	Supported

For detailed information on the A2DP profile, see the A2DP Profile Specification at [Adopted Bluetooth Core Specifications](#).

5.7.2.1 Assisted A2DP Sink

The A2DP sink role is the receiver of the audio stream in an A2DP *Bluetooth* connection. In this role, the A2DP layer and its underlying layers are responsible for link management and data decoding. To handle these tasks, two logic transports are defined:

- Control and signaling logic transport
- Data packet logic transport

The assisted A2DP takes advantage of this modularity to handle the data packet logic transport in the module by implementing a light L2CAP layer (L-L2CAP) and light AVDTP layer (L-AVDTP) to defragment the packets. Then the assisted A2DP performs the SBC decoding on-chip to deliver raw audio data through the module PCM-I2S interface. [Figure 5-8](#) shows the comparison between a common A2DP sink architecture and the assisted A2DP sink architecture.

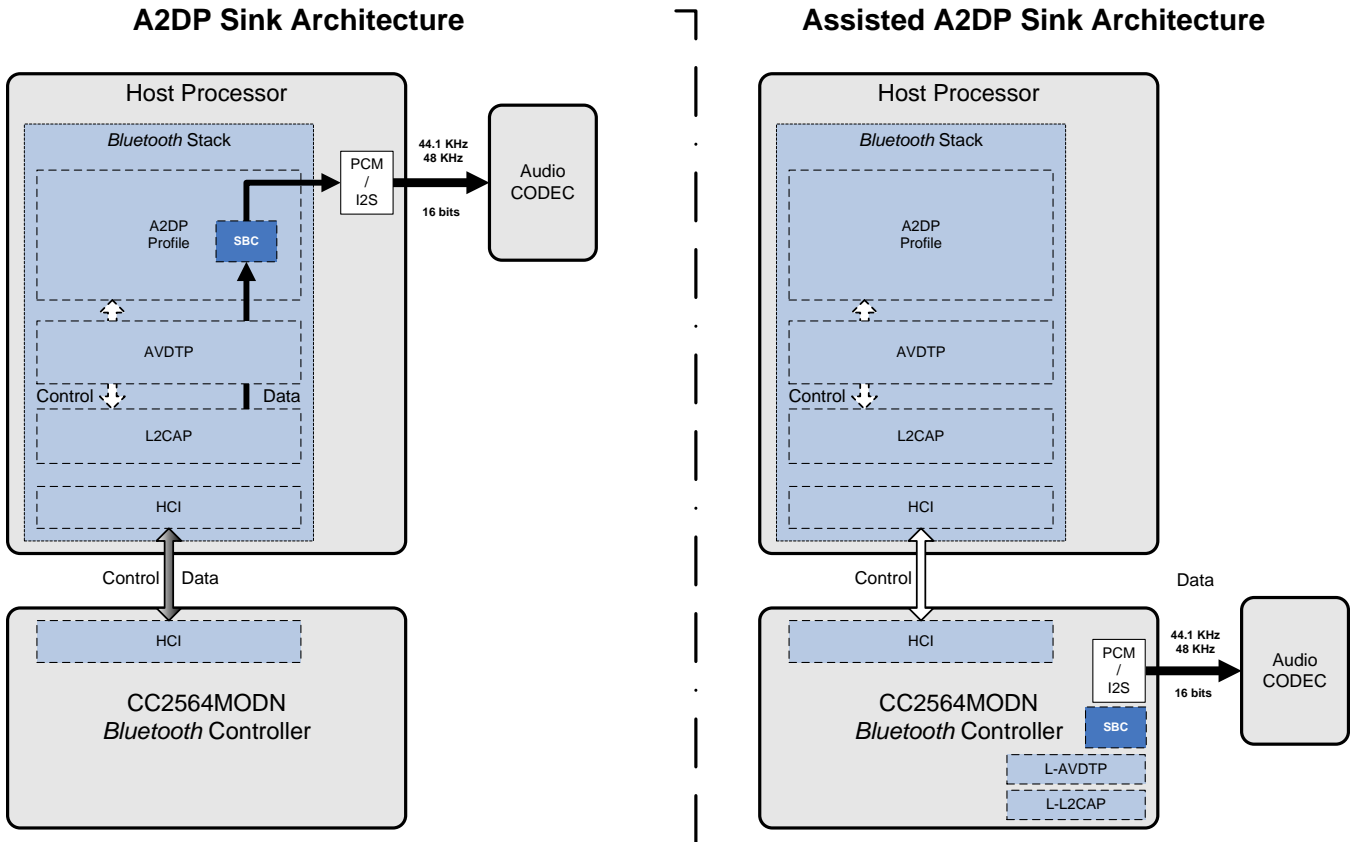

Figure 5-8. A2DP Sink Architecture Versus Assisted A2DP Sink Architecture

For more information on the A2DP sink role, see the A2DP Profile Specification at [Adopted Bluetooth Core Specifications](#).

5.7.2.2 Assisted A2DP Source

The role of the A2DP source is to transmit the audio stream in an A2DP *Bluetooth* connection. In this role, the A2DP layer and its underlying layers are responsible for link management and data encoding. To handle these tasks, two logic transports are defined:

- Control and signaling logic transport
- Data packet logic transport

The assisted A2DP takes advantage of this modularity to handle the data packet logic transport in the module. First, the assisted A2DP encodes the raw data from the module PCM–I2S interface using an on-chip SBC encoder. The assisted A2DP then implements an L-L2CAP layer and an L-AVDTP layer to fragment and packetize the encoded audio data. [Figure 5-9](#) shows the comparison between a common A2DP source architecture and the assisted A2DP source architecture.

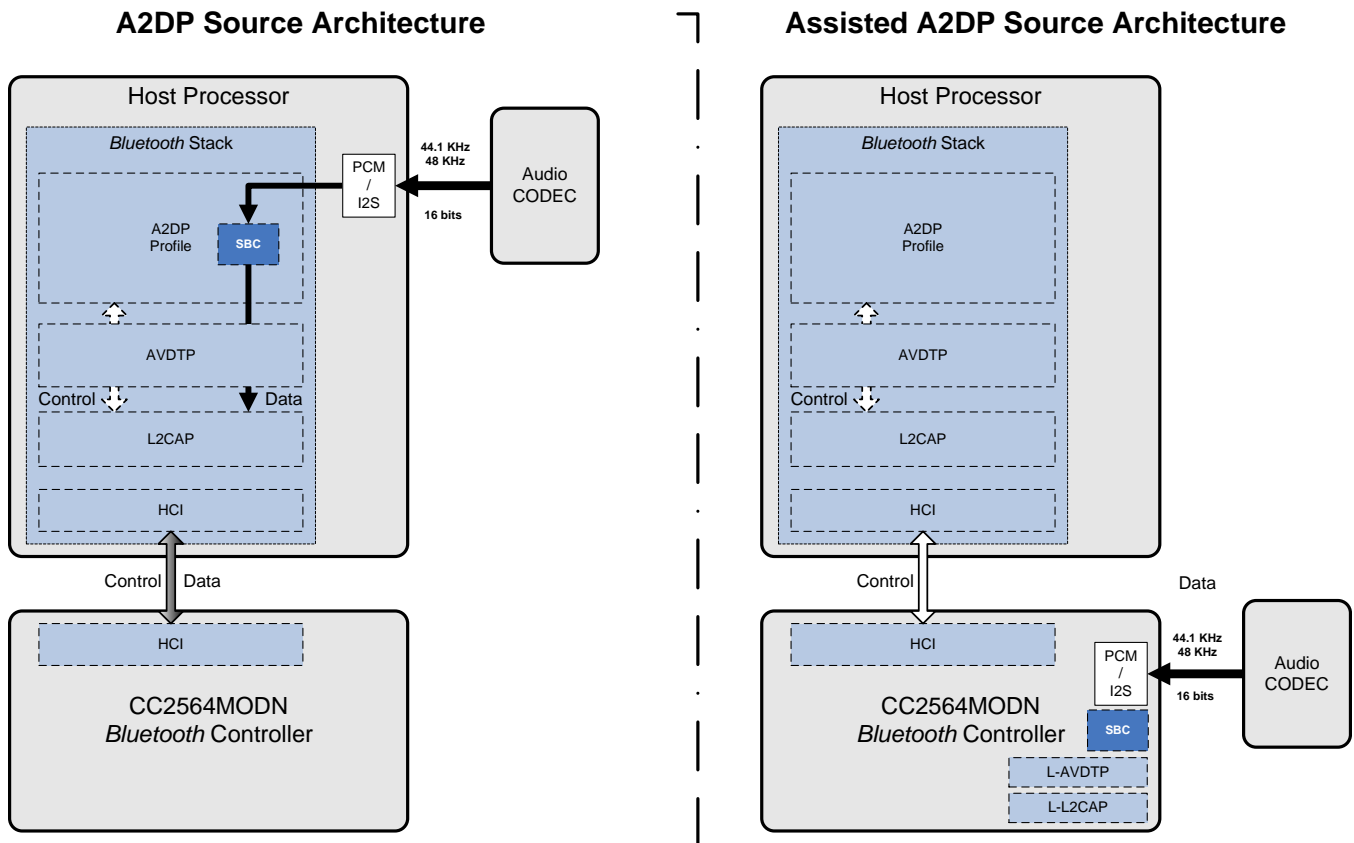

Figure 5-9. A2DP Source Architecture Versus Assisted A2DP Source Architecture

For more information on the A2DP source role, see the A2DP Profile Specification at [Adopted Bluetooth Core Specifications](#).

6 Applications, Implementation, and Layout

6.1 Reference Design Schematics

Figure 6-1 shows the reference schematics for the TI Bluetooth HCI module.

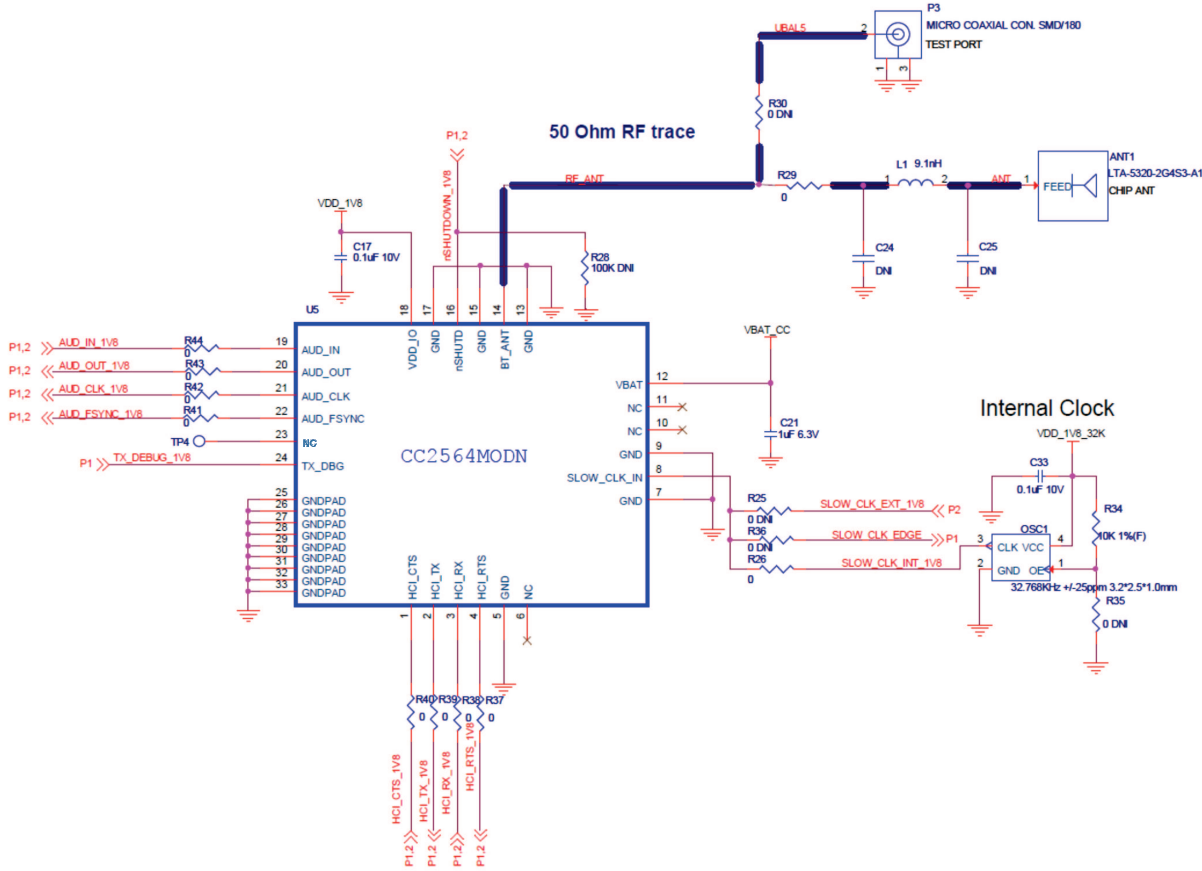

Figure 6-1. Reference Schematics

6.2 Layout

This section provides the printed circuit board (PCB) layout rules and considerations, including component placement and routing guidelines, when designing a board with the CC2564MODN module.

The integrator of the CC2564MODN module must comply with the PCB layout recommendations described in the following subsections to preserve the FCC and Industry Canada (IC) modular radio certification. Moreover, TI recommends customers follow the guidelines described in this section to achieve similar performance to that obtained with the TI reference design.

6.2.1 Layout Guidelines

6.2.1.1 PCB Stack-Up

The recommended PCB stack-up is a four-layer design based on a standard flame-retardant 4 (FR4) material (see Figure 6-2).

Layer 1 (TOP - RF + Signal) Use layer 1 to place the module on and to route signal traces. In particular, the RF trace must be run on this layer.

Layer 2 (L2 - Ground) Layer 2 must be a solid ground layer.

Layer 3 (L3 - Power) Use layer 3 to route power traces or place power planes.

Layer 4 (BOTTOM - Signal) Use layer 4 as a second routable layer to run signal traces (except RF signals).

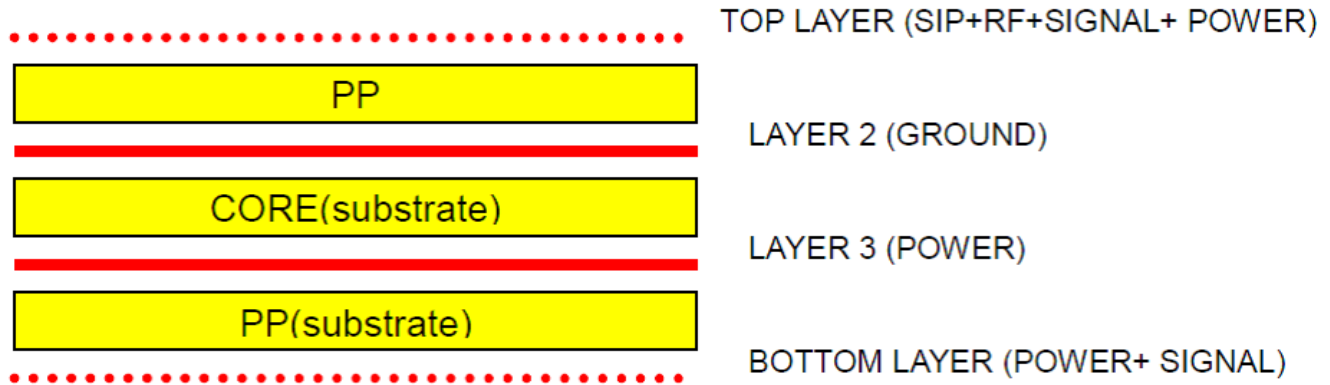

Figure 6-2. PCB Stack-Up

TI recommends a board thickness of 62.4 mils and a substrate dielectric of 4.2. For details, see [Table 6-1](#).

NOTE

These parameters are used for the 50-Ω impedance matching of the RF trace. For more information, see [Section 6.2.1.2, RF Interface Guidelines](#).

Table 6-1. Recommended PCB Properties

Item	Value
Solder mask	0.4 mil
TOP copper + plating	1 oz/1.4 mil
PP (substrate)	10 mil
L2 copper + plating	1 oz/1.4 mil
Core (substrate)	36 mil
L3 copper + plating	1 oz/1.4 mil
PP (substrate)	10 mil
Bottom copper + plating	1 oz/1.4 mil
Solder mask	0.4 mil
Final thickness	62.4 mil = 1.585 mm

6.2.1.2 RF Interface Guidelines

6.2.1.2.1 RF Trace

Route the RF traces on layer 1 (top) and keep the routes as short as possible. These traces must be 50- Ω , controlled-impedance traces with reference to the solid ground in the layer 2-microstrip transmission line. The TI reference design uses an RF trace width equal to 17 mils, which conforms to a 50 $\Omega \pm 3\%$ simulated result, based on the following PCB properties: (see [Table 6-1](#) and [Figure 6-3](#)).

- Substrate height: 10 mils
- Substrate dielectric: 4.2
- Trace width: 17 mils
- Trace thickness: 1.4 mils
- Ground clearance: 20 mils

TI recommends the following guidelines for a good RF trace design:

- The RF traces must have via stitching on both ground planes around the RF trace (see [Figure 6-3](#)).
- Avoid placing clock signals close to the RF path.
- Place a u.FL connector (or similar) between the module and antenna if possible or during prototype phases (see [Figure 6-3](#).)
- The RF path should look like one single path along the RF traces and matching components. See [Figure 6-4](#) for the good (OK) case versus the not good (NG) case.
- The RF trace bends must be gradual with an approximate maximum bend of 45 degrees with trace mitered. RF traces must not have sharp corners. In addition:
 - Avoid case (1) in [Figure 6-5](#). A right angle leads to scattering and makes matching weak.
 - Case (2) in [Figure 6-5](#) is not recommended. Even if this bend had a good 50 Ω , a careful simulation would be required.
 - Case (3) in [Figure 6-5](#) is recommended. The half-arc angle reduces scattering caused by a right angle.

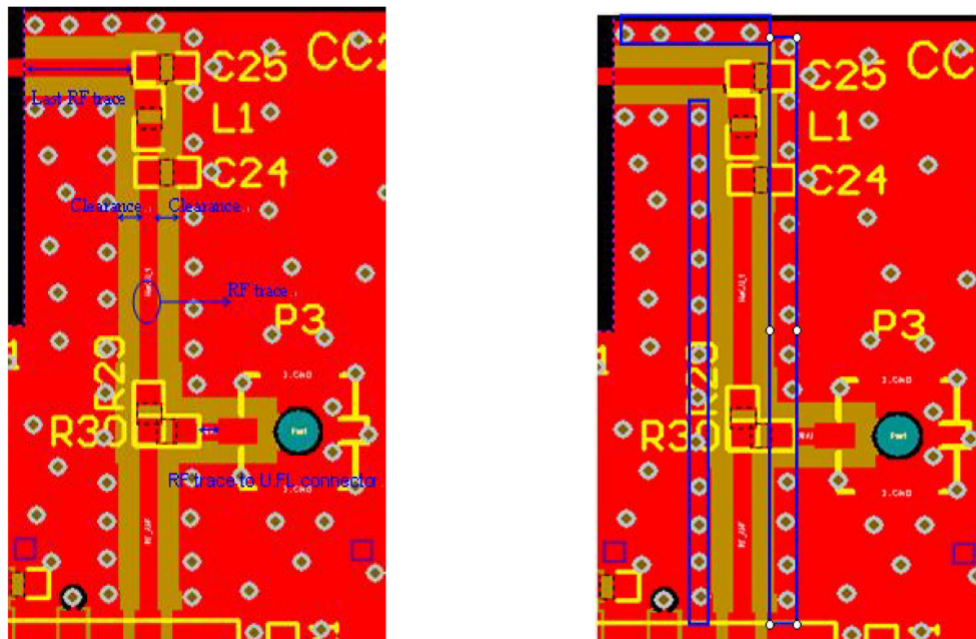

Figure 6-3. Placing a u.FL Connector Between the Module and Antenna

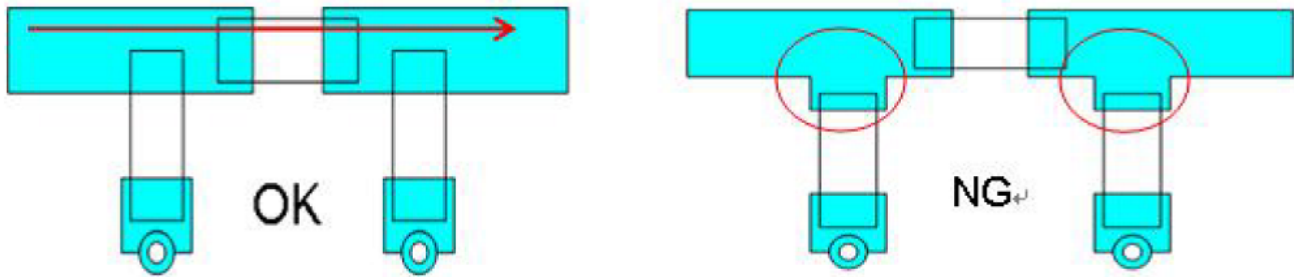

Figure 6-4. Good (OK) vs Not Good (NG) RF Path

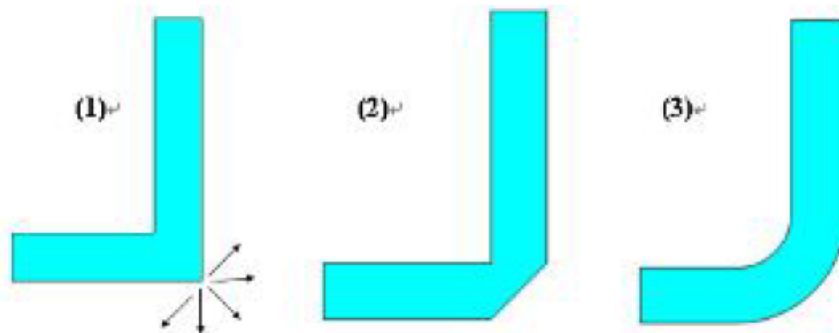

Figure 6-5. Not Recommended vs Recommended Trace Bends

6.2.1.3 Antenna

The module must be used with the approved chip antenna (LTA-5320-2G4S3-A) and must comply with the following guidelines to preserve the modular radio certification (see [Figure 6-6](#)).

- Antenna clearance area = 15 mm × 8 mm
- Antenna solder termination to board edge length = 186 mils
- Antenna feed point to right side ground length = 140 mils
- Antenna feed point to last component trace = 244 mils
- Antenna pads to inside ground length = 208 mils
- An inductor L1 = 9.1 nH is required to properly match the chip antenna.

In addition, follow these general recommendations for a proper design with any antenna:

- Place the matching circuit as close as possible to the antenna feed point.
- Do not place traces or ground under the antenna section.
- Place the antenna, RF traces, and modules on the edge of the PCB product. In addition, consider the proximity of the antenna to the enclosure and consider the enclosure material.

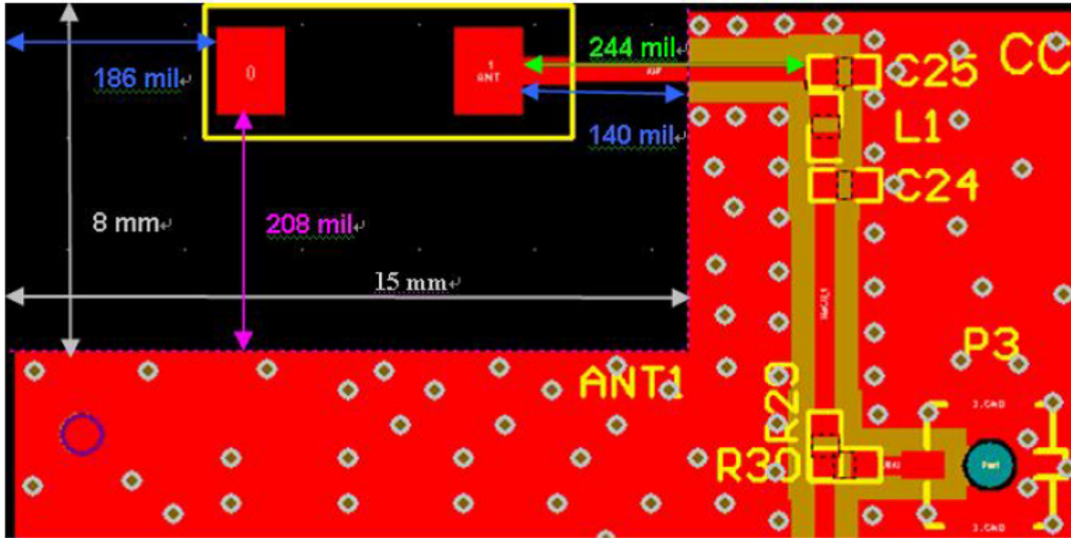

Figure 6-6. Antenna Guidelines

6.2.1.4 Power Supply and Ground Guidelines

6.2.1.4.1 Power Traces

TI recommends the following guidelines for the power supply of the CC2564MODN module:

- Use a star pattern format to supply power to the different pads of the module.
- Keep the power traces (VBAT and VIO) more than 14 mils.
- Use short power supply traces.
- Place decoupling capacitors as close as possible to the module (see Figure 6-7).

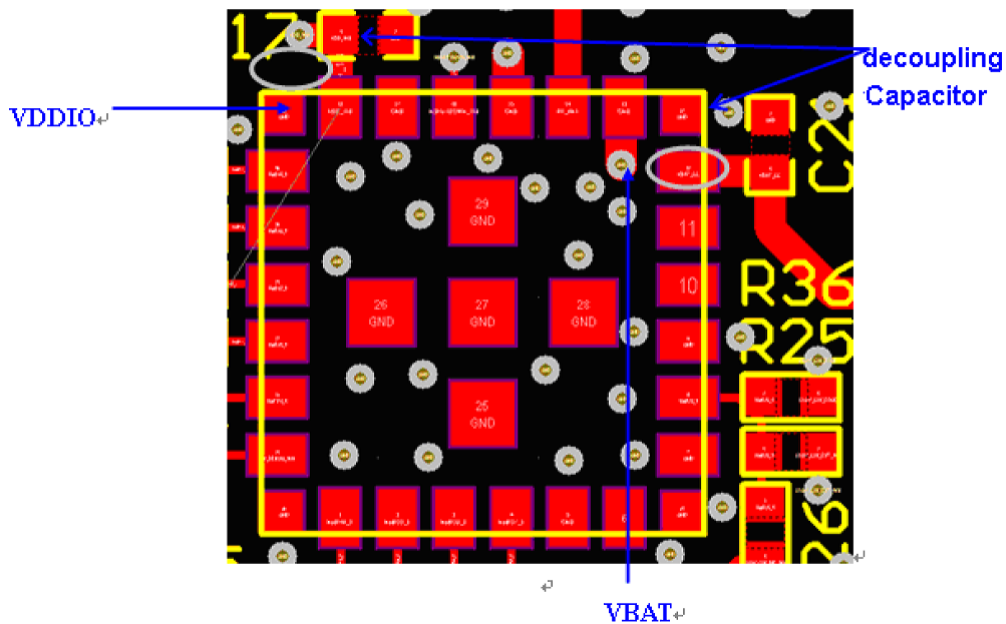

Figure 6-7. Placing Decoupling Capacitors as Close as Possible to the Module

6.2.1.4.2 Ground

The common ground must be the solid ground plane in layer 2. TI recommends using a large ground pad under the module and placing enough ground vias beneath for a stable system and thermal dissipation (see [Figure 6-8](#)).

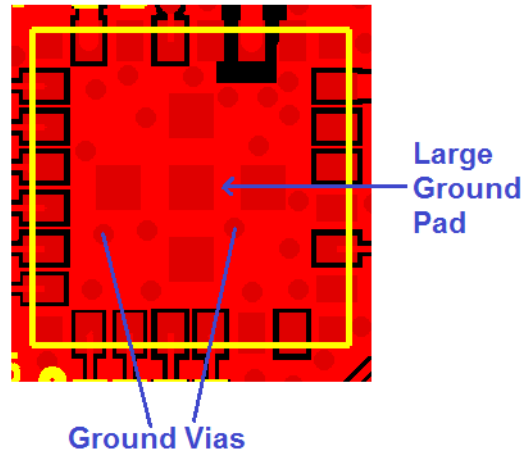

Figure 6-8. Using a Large Ground Pad Under the Module

6.2.1.5 Clock Guidelines

Remember that clock signal routing directly influences RF performance because of the signal trace susceptibility to noise.

6.2.1.5.1 Slow Clock

TI recommends the following guidelines:

- Keep the slow clock signal lines as short as possible and at least 4-mils wide.
- Traces of slow clock signals must have a ground plane on each side of the signal trace to reduce undesired signal coupling.
- To reduce the capacitive coupling of undesired signals into the clock line, do not route slow clock traces above or below other signals (especially digital signals). [Figure 6-9](#) shows the slow clock trace in the TI reference design.

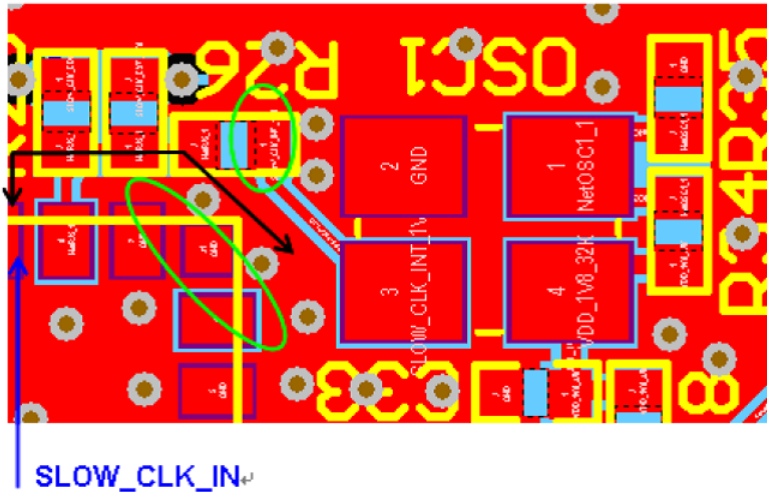

Figure 6-9. Slow Clock Trace in TI Reference Design

6.2.1.6 Digital Interface Guidelines

6.2.1.6.1 UART

The CC2564MODN UART default baud rate is 115.2 kbps but can run up to 4 Mbps. TI recommends separating these lines from the DC supply lines, RF lines, and sensitive clock lines and circuitry. To improve the return path and isolation, run the lines with ground on the adjacent layer when possible.

6.2.1.6.2 PCM

The digital audio lines (pulse-code modulation [PCM]) are high-speed digital lines in which the four wires (AUD_CLK, AUD_FSYNC, AUD_IN, and AUD_OUT) must be roughly the same length. TI recommends running these lines as a bus interface (see Figure 6-10). These lines are high-speed digital and must be separated from DC supply lines, RF lines, and sensitive clock lines and circuitry. Run the lines with ground on the adjacent layer to improve the return path and isolation.

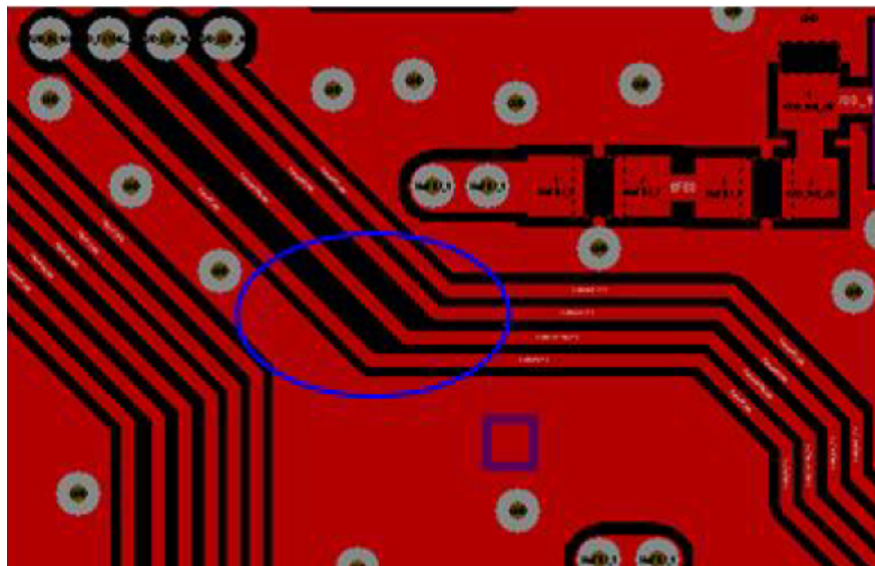

Figure 6-10. Running the Digital Audio Lines

6.2.2 Reference Design Drawings

Figure 6-11 through Figure 6-16 shows the PCB layers and assembly drawings for the CC2564MODNEM reference design board. For more information (such as schematics, BOM, and design files), see TI's [CC2564MODN Reference Design product page](#).

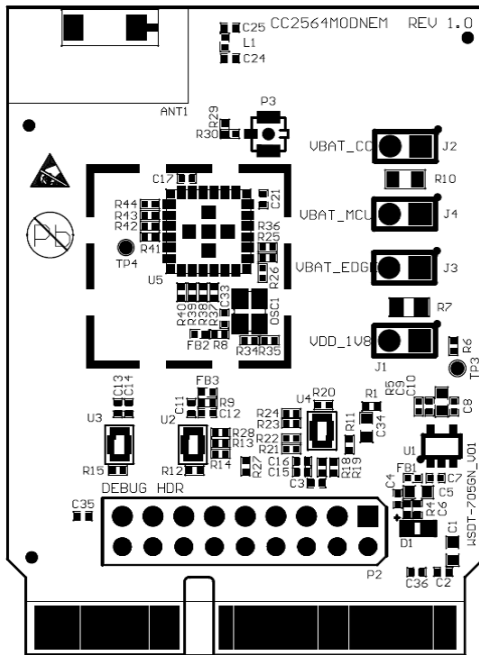

Figure 6-11. Top Silkscreen

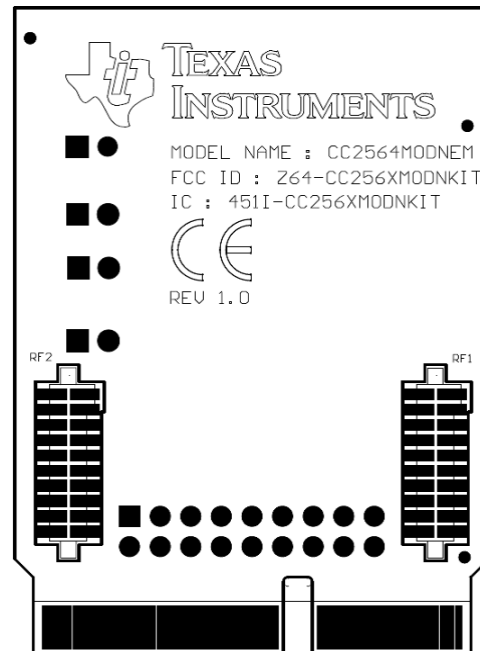

Figure 6-12. Bottom Silkscreen

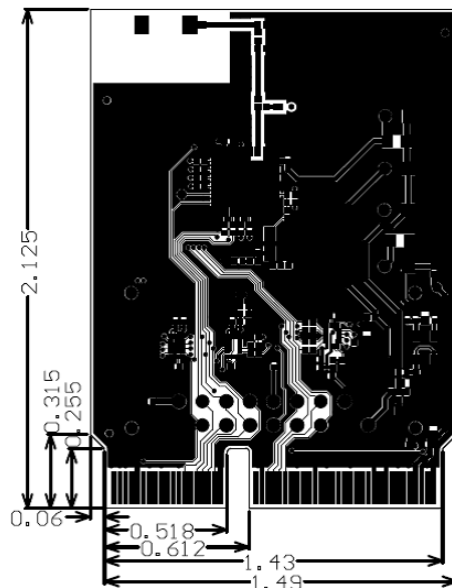

Figure 6-13. Layer 1

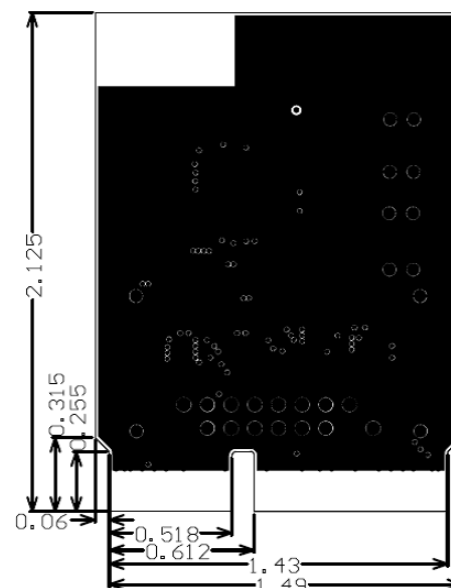

Figure 6-14. Layer 2

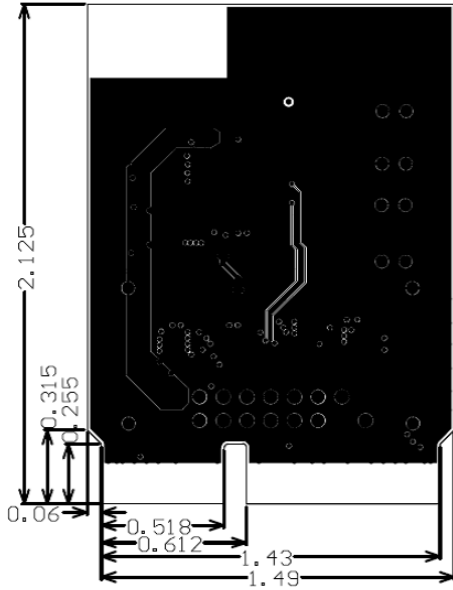

Figure 6-15. Layer 3

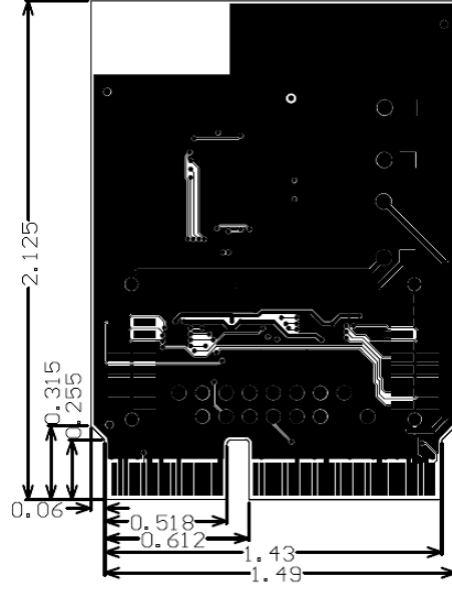

Figure 6-16. Layer 4

6.3 Soldering Recommendations

Figure 6-17 shows the recommended reflow profile.

Referred to IPC/JEDEC standard.
 Peak Temperature : <250°C
 Number of Times : ≤2 times

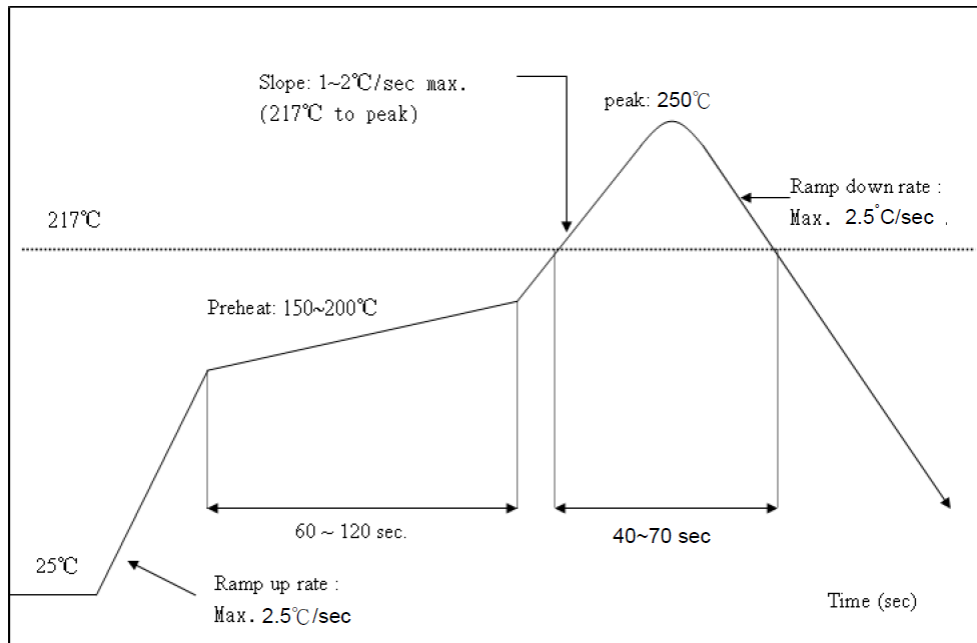

Figure 6-17. Reflow Profile

7 Device and Documentation Support

7.1 Device Certification and Qualification

The TI CC2564MODN module is certified for the FCC, IC, and ETSI/CE. Moreover, the module is a *Bluetooth* Qualified Design by the *Bluetooth* Special Interest Group (*Bluetooth* SIG). TI Customers that build products based on the TI CC2564MODN module can save in testing cost and time per product family.

For more information, see the [CC256x Regulatory Compliance wiki](#) and the [CC256x Bluetooth SIG Qualification wiki](#).

7.1.1 FCC Certification

The TI CC2564MODN module is certified for the FCC as a single-modular transmitter. The module is a FCC-certified radio module that carries a modular grant. The module complies with the intentional radiator portion (Part 15c) of the FCC certification: Part 15.247 transmitter tests. For more information, see [CC2564MODN Modular Grant, FCC ID: Z64-2564N](#).

7.1.2 IC Certification

The TI CC2564MODN module is certified for the IC as a single-modular transmitter. The TI CC2564MODN module meets IC modular approval and labeling requirements. The IC follows the same testing and rules as the FCC regarding certified modules in authorized equipment. For more information, see [CC2564MODN Modular Grant, IC ID: 451I-2564N](#).

7.1.3 ETSI/CE Certification

The TI CC2564MODN module is CE certified with certifications to the appropriate EU radio and EMC directives summarized in the Declaration of Conformity and evidenced by the CE mark. The module is tested against the ETSI EN300-328 v1.8.1 radio tests, which is accepted by a number of countries for radio compliance. For more information, see [CC2564MODN DoC](#).

7.1.4 Bluetooth Special Interest Group Qualification

The TI CC2564MODN module is *Bluetooth* qualified and carries a Bluetooth 4.1 Controller Subsystem Qualification Design ID (QDID), which covers the lower layers of a *Bluetooth* design up to the HCI layer. TI customers that build products based on the TI CC2564MODN module can reference this QDID in their *Bluetooth* product Listing. For more information, see [CC2564MODN Controller Subsystem, QDID 55257](#).

7.2 Device Support

7.2.1 Development Support

For a complete listing of development-support tools, see the TI [CC256x wiki](#). For information on pricing and availability, contact the nearest TI field sales office or authorized distributor.

7.2.2 Device Nomenclature

To designate the stages in the product development cycle, TI assigns prefixes to the part numbers. These prefixes represent evolutionary stages of product development from engineering prototypes through fully qualified production devices.

- X Experimental, preproduction, sample or prototype device. Device may not meet all product qualification conditions and may not fully comply with TI specifications. Experimental/Prototype devices are shipped against the following disclaimer: "This product is still in development and is intended for internal evaluation purposes." Notwithstanding any provision to the contrary, TI makes no warranty expressed, implied, or statutory, including any implied warranty of merchantability of fitness for a specific purpose, of this device.
- null Device is qualified and released to production. TI's standard warranty applies to production devices.

7.2.3 Documentation Support

In future revisions of this data sheet, this section will list supporting documents for the CC2564MODN device.

7.3 Community Resources

The following links connect to TI community resources. Linked contents are provided "AS IS" by the respective contributors. They do not constitute TI specifications and do not necessarily reflect TI's views; see TI's [Terms of Use](#).

[TI E2E™ Online Community](#) *TI's Engineer-to-Engineer (E2E) Community*. Created to foster collaboration among engineers. At e2e.ti.com, you can ask questions, share knowledge, explore ideas and help solve problems with fellow engineers.

[TI Embedded Processors Wiki](#) *Texas Instruments Embedded Processors Wiki*. Established to help developers get started with Embedded Processors from Texas Instruments and to foster innovation and growth of general knowledge about the hardware and software surrounding these devices.

7.4 Trademarks

MSP430, E2E are trademarks of Texas Instruments.
Cortex is a registered trademark of ARM Limited.
ARM is a registered trademark of ARM Physical IP, Inc.
iPod is a registered trademark of Apple, Inc.
Bluetooth is a registered trademark of Bluetooth SIG, Inc.

7.5 Electrostatic Discharge Caution



This integrated circuit can be damaged by ESD. Texas Instruments recommends that all integrated circuits be handled with appropriate precautions. Failure to observe proper handling and installation procedures can cause damage.

ESD damage can range from subtle performance degradation to complete device failure. Precision integrated circuits may be more susceptible to damage because very small parametric changes could cause the device not to meet its published specifications.

7.6 Glossary

[SLYZ022](#) — *TI Glossary*.

This glossary lists and explains terms, acronyms, and definitions.

8 Mechanical, Packaging, and Orderable Information

The following pages include mechanical packaging and orderable information. This information is the most current data available for the designated devices. This data is subject to change without notice and revision of this document. For browser-based versions of this data sheet, refer to the left-hand navigation.

8.1 Module Outline

Figure 8-1 shows the outline of the TI *Bluetooth* HCI module.

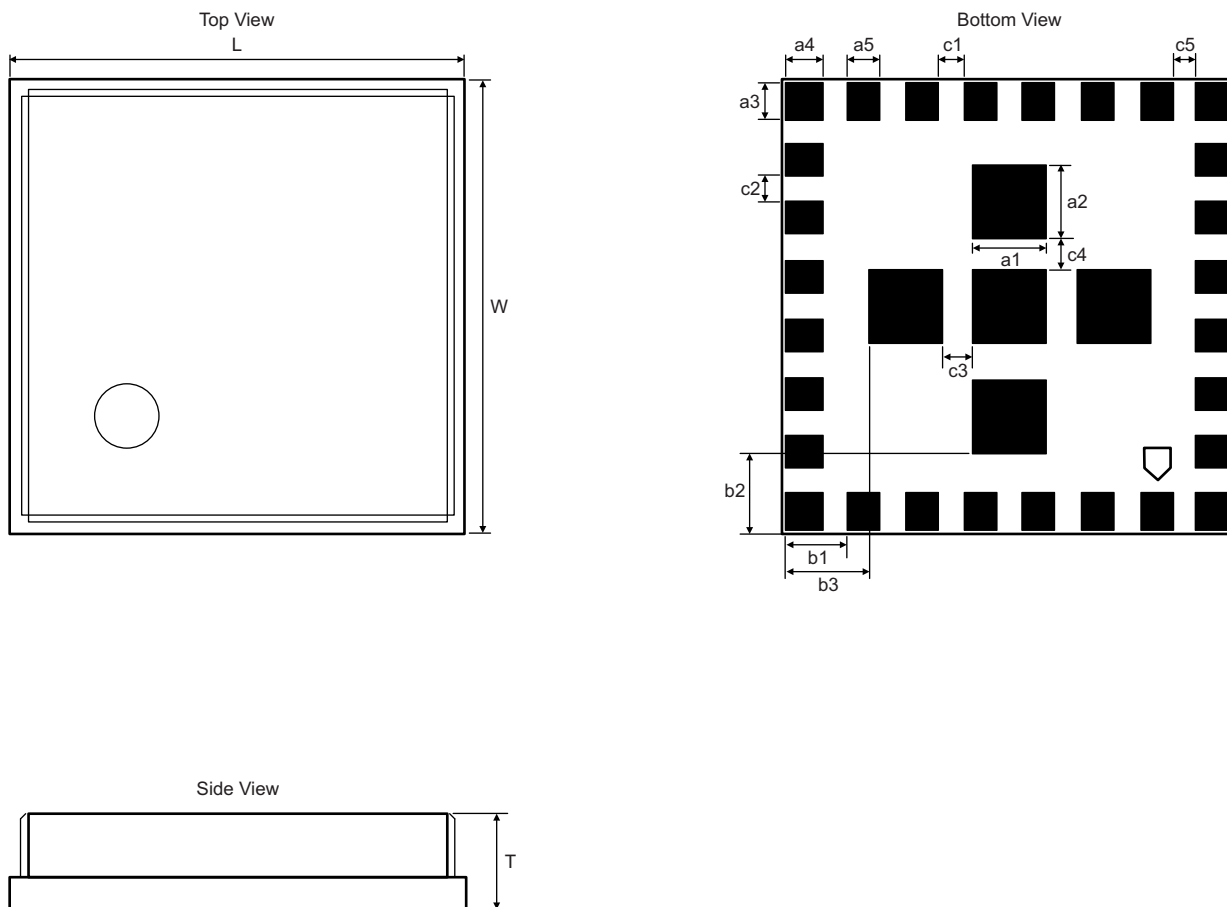

SWRS160-012

Figure 8-1. Outline of TI *Bluetooth* HCI Module

Table 8-1 lists the dimensions of the TI *Bluetooth* HCI module outline.

Table 8-1. Dimensions of TI *Bluetooth* HCI Module Mechanical Outline

Marking	Dimensions (mm)	Marking	Dimensions (mm)
L (body size)	7.0 (± 0.1)	b1	0.95 (± 0.1)
W (body size)	7.0 (± 0.1)	b2	1.35 (± 0.15)
T (thickness)	1.4 (max)	b3	1.35 (± 0.15)
a1	1.1 (± 0.15)	c1	0.4 (± 0.05)
a2	1.1 (± 0.15)	c2	0.4 (± 0.05)
a3	0.6 (± 0.1)	c3	0.5 (± 0.1)
a4	0.6 (± 0.1)	c4	0.5 (± 0.1)
a5	0.5 (± 0.1)	c5	0.35 (± 0.05)

8.2 Mechanical Data

MOE(R-MSIP-N33)

METAL SINGLE-IN-LINE MODULE

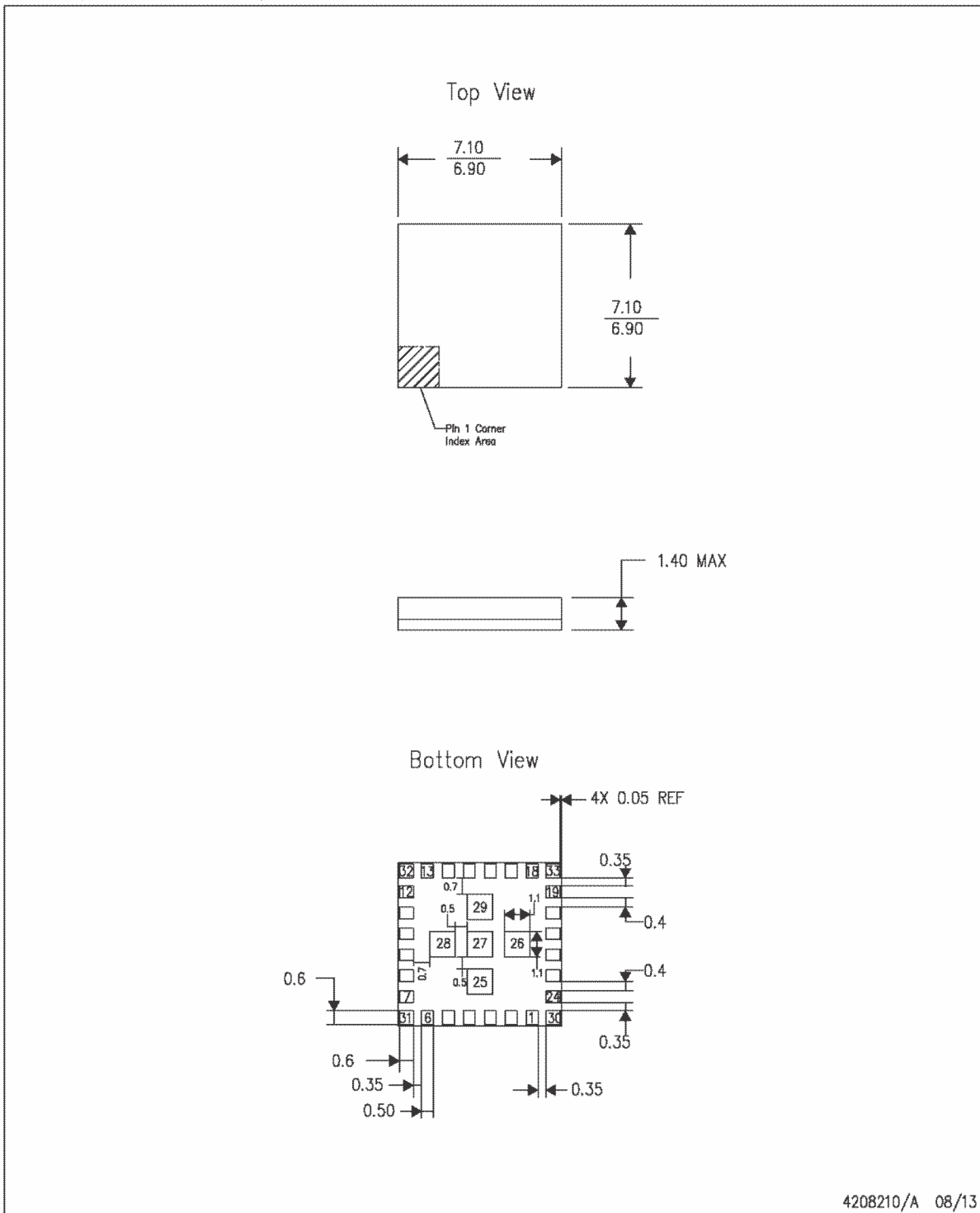

NOTES: A. All linear dimensions are in millimeters. Dimensioning and tolerancing per ASME Y14.5M-1994.
 B. This drawing is subject to change without notice.

8.3 Packaging and Ordering

8.3.1 Package and Ordering Information

Table 8-2. Package and Order Information

Part Number ⁽¹⁾	Status	Package Type	Minimum Orderable Quantity
CC2564MODNMOET	Active	MOE	250
CC2564MODNMOER	Active	MOE	2000

- (1) Part number marking key:
- CC2564 – module variant
 - MODNC – module marking (commercial)
 - MOEx – module package designator (R: tape/reel; T: small reel)

Figure 8-2 shows the markings for the TI Bluetooth HCI module.

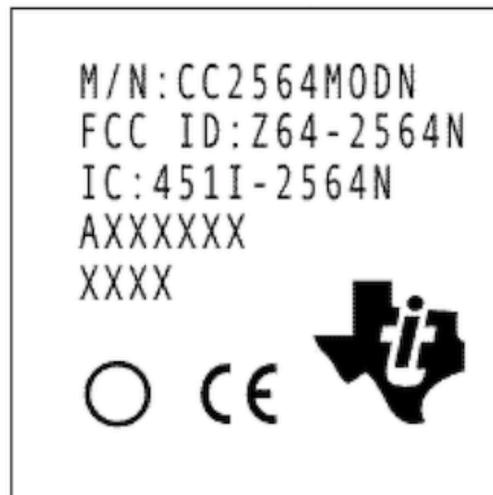

Figure 8-2. CC2564MODN Markings

Table 8-3 describes the CC2564MODN markings.

Table 8-3. CC2564MODN Markings

Marking	Description
CC2564MODN	Model number
Z64 - 2564N	FCC ID: single modular FCC grant ID
451I - 2564N	IC: single modular IC grant ID
AXXXXXX	Lot order code (for example, A0A7123): <ul style="list-style-type: none"> • A = fixed • Second and third digits = year code by hex (for example, 0A = 2010) • Fourth digit = month code by hex (for example, 7 = July) • Fifth to seventh digit = serial number by hex (for example, 123)
XXXX	Production date code (for example, 1424): <ul style="list-style-type: none"> • XX = year (for example, 14 = 2014) • XX = week (for example, 24 = week 24)
CE	CE compliance mark

8.3.2 Empty Tape Portion

Figure 8-3 shows the empty portion of the carrier tape.

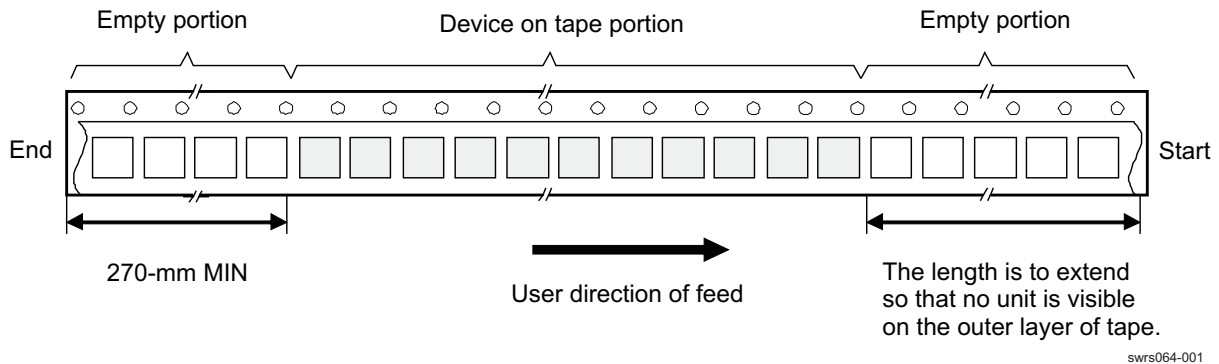

Figure 8-3. Carrier Tape and Pockets

8.3.3 Device Quantity and Direction

When pulling out the tape, the A1 corner is on the left side (see Figure 8-4).

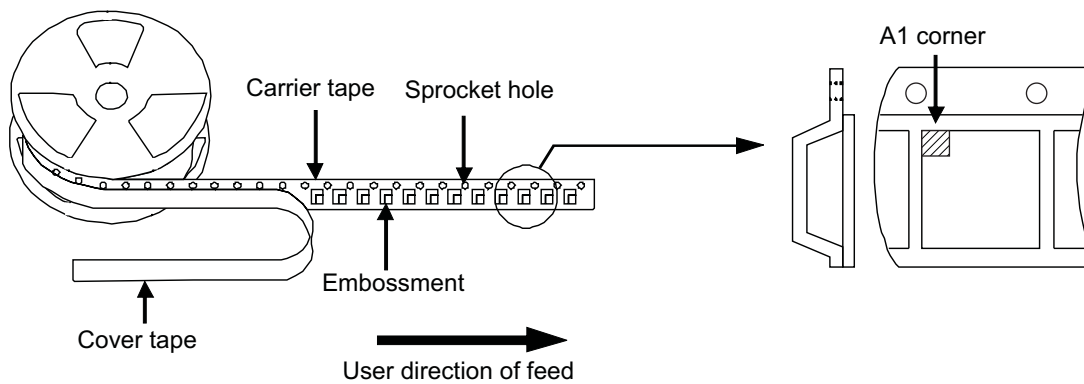

Figure 8-4. Direction of Device

8.3.4 Insertion of Device

Figure 8-5 shows the insertion of the device.

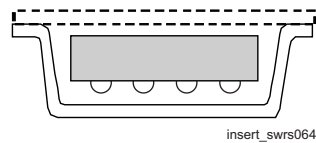

Figure 8-5. Insertion of Device

8.3.5 Tape Specification

Figure 8-6 shows the dimensions of the tape.

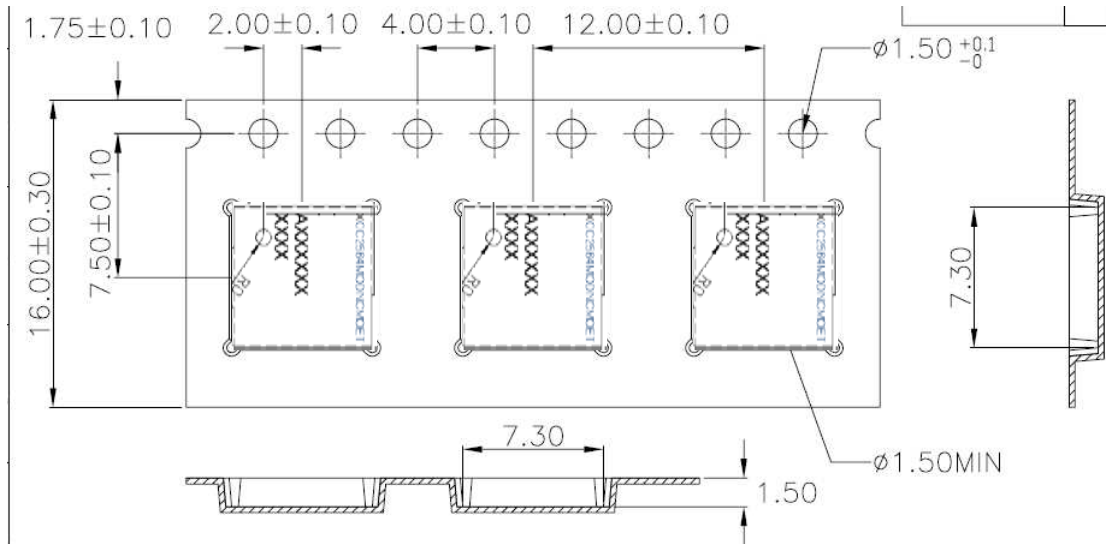

Figure 8-6. Tape Dimensions (mm)

- Cumulative tolerance of the 10-sprocket hole pitch is ± 0.20 .
- Carrier camber is within 1 mm in 250 mm.
- Material is black conductive polystyrene alloy.
- All dimensions meet EIA-481-D requirements.
- Thickness: 0.30 ± 0.05 mm
- Packing length per 22-inch reel is 110.5 m (1:3).
- Component load per 13-inch reel is 2000 pieces.

8.3.6 Reel Specification

Figure 8-7 shows the reel specifications:

- 330-mm reel, 12-mm width tape
- Reel material: Polystyrene (static dissipative/antistatic)

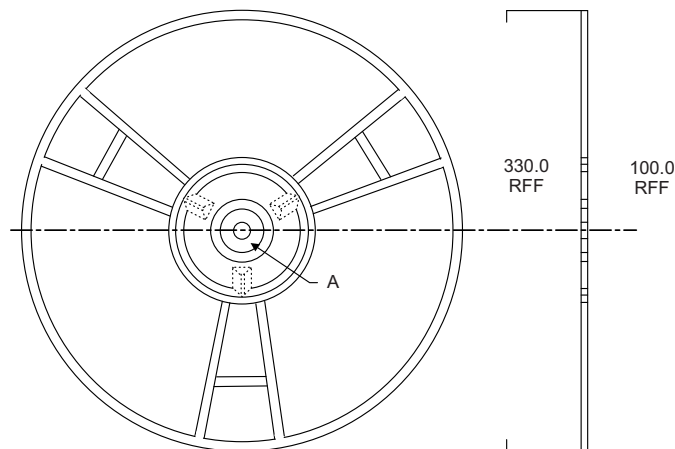

Figure 8-7. Reel Dimensions (mm)

8.3.7 Packing Method

Figure 8-8 shows the reel packing method.

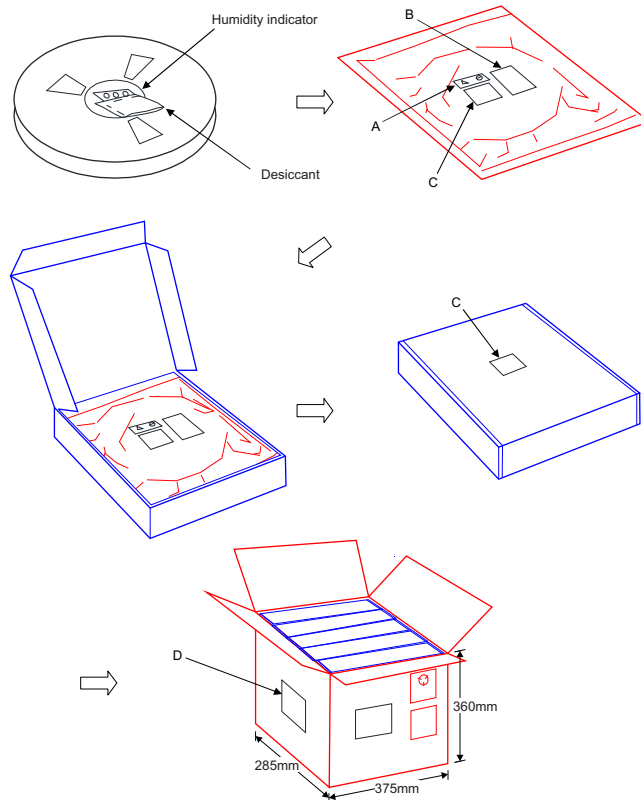
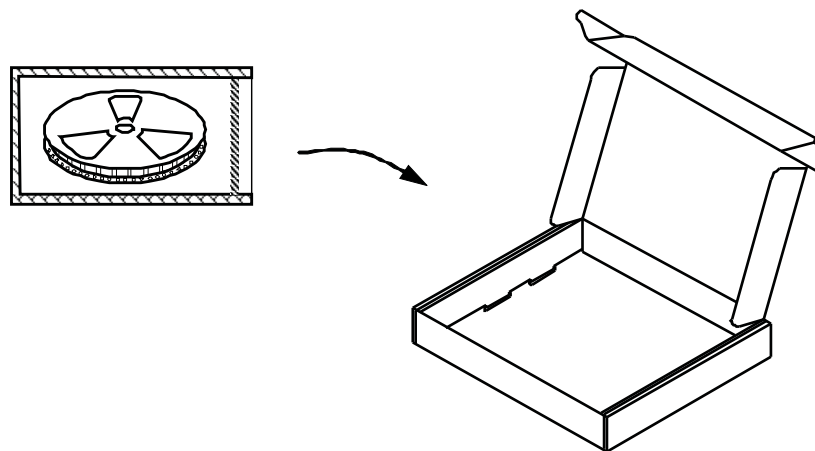

Figure 8-8. Reel Packing Method

8.3.8 Packing Specification

8.3.8.1 Reel Box

Each moisture-barrier bag is packed into a reel box, as shown in Figure 8-9.



rlbx_swrs064

Figure 8-9. Reel Box (Carton)

8.3.8.2 Reel Box Material

The reel box is made from corrugated fiberboard.

8.3.8.3 Shipping Box

If the shipping box has excess space, filler (such as cushion) is added.

Figure 8-10 shows a typical shipping box.

NOTE

The size of the shipping box may vary depending on the number of reel boxes packed.

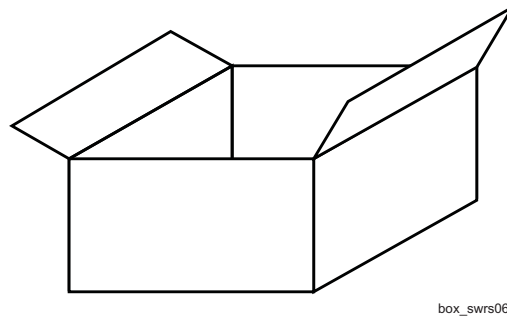

box_swrs064

Figure 8-10. Shipping Box (Carton)

8.3.8.4 Shipping Box Material

The shipping box is made from corrugated fiberboard.

8.3.8.5 Labels

Figure 8-11 shows the antistatic and humidity notice.



Figure 8-11. Antistatic and Humidity Notice

Figure 8-12 shows the MSL caution and storage condition notice.

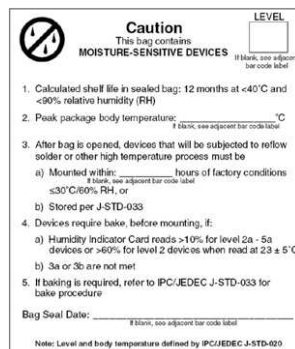

Figure 8-12. MSL Caution and Storage Condition Notice

Figure 8-13 shows the label for the inner box.

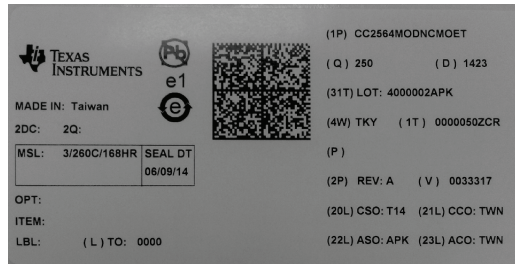

Figure 8-13. Inner Box Label Example

IMPORTANT NOTICE

Texas Instruments Incorporated and its subsidiaries (TI) reserve the right to make corrections, enhancements, improvements and other changes to its semiconductor products and services per JESD46, latest issue, and to discontinue any product or service per JESD48, latest issue. Buyers should obtain the latest relevant information before placing orders and should verify that such information is current and complete. All semiconductor products (also referred to herein as "components") are sold subject to TI's terms and conditions of sale supplied at the time of order acknowledgment.

TI warrants performance of its components to the specifications applicable at the time of sale, in accordance with the warranty in TI's terms and conditions of sale of semiconductor products. Testing and other quality control techniques are used to the extent TI deems necessary to support this warranty. Except where mandated by applicable law, testing of all parameters of each component is not necessarily performed.

TI assumes no liability for applications assistance or the design of Buyers' products. Buyers are responsible for their products and applications using TI components. To minimize the risks associated with Buyers' products and applications, Buyers should provide adequate design and operating safeguards.

TI does not warrant or represent that any license, either express or implied, is granted under any patent right, copyright, mask work right, or other intellectual property right relating to any combination, machine, or process in which TI components or services are used. Information published by TI regarding third-party products or services does not constitute a license to use such products or services or a warranty or endorsement thereof. Use of such information may require a license from a third party under the patents or other intellectual property of the third party, or a license from TI under the patents or other intellectual property of TI.

Reproduction of significant portions of TI information in TI data books or data sheets is permissible only if reproduction is without alteration and is accompanied by all associated warranties, conditions, limitations, and notices. TI is not responsible or liable for such altered documentation. Information of third parties may be subject to additional restrictions.

Resale of TI components or services with statements different from or beyond the parameters stated by TI for that component or service voids all express and any implied warranties for the associated TI component or service and is an unfair and deceptive business practice. TI is not responsible or liable for any such statements.

Buyer acknowledges and agrees that it is solely responsible for compliance with all legal, regulatory and safety-related requirements concerning its products, and any use of TI components in its applications, notwithstanding any applications-related information or support that may be provided by TI. Buyer represents and agrees that it has all the necessary expertise to create and implement safeguards which anticipate dangerous consequences of failures, monitor failures and their consequences, lessen the likelihood of failures that might cause harm and take appropriate remedial actions. Buyer will fully indemnify TI and its representatives against any damages arising out of the use of any TI components in safety-critical applications.

In some cases, TI components may be promoted specifically to facilitate safety-related applications. With such components, TI's goal is to help enable customers to design and create their own end-product solutions that meet applicable functional safety standards and requirements. Nonetheless, such components are subject to these terms.

No TI components are authorized for use in FDA Class III (or similar life-critical medical equipment) unless authorized officers of the parties have executed a special agreement specifically governing such use.

Only those TI components which TI has specifically designated as military grade or "enhanced plastic" are designed and intended for use in military/aerospace applications or environments. Buyer acknowledges and agrees that any military or aerospace use of TI components which have **not** been so designated is solely at the Buyer's risk, and that Buyer is solely responsible for compliance with all legal and regulatory requirements in connection with such use.

TI has specifically designated certain components as meeting ISO/TS16949 requirements, mainly for automotive use. In any case of use of non-designated products, TI will not be responsible for any failure to meet ISO/TS16949.

Products

Audio	www.ti.com/audio
Amplifiers	amplifier.ti.com
Data Converters	dataconverter.ti.com
DLP® Products	www.dlp.com
DSP	dsp.ti.com
Clocks and Timers	www.ti.com/clocks
Interface	interface.ti.com
Logic	logic.ti.com
Power Mgmt	power.ti.com
Microcontrollers	microcontroller.ti.com
RFID	www.ti-rfid.com
OMAP Applications Processors	www.ti.com/omap
Wireless Connectivity	www.ti.com/wirelessconnectivity

Applications

Automotive and Transportation	www.ti.com/automotive
Communications and Telecom	www.ti.com/communications
Computers and Peripherals	www.ti.com/computers
Consumer Electronics	www.ti.com/consumer-apps
Energy and Lighting	www.ti.com/energy
Industrial	www.ti.com/industrial
Medical	www.ti.com/medical
Security	www.ti.com/security
Space, Avionics and Defense	www.ti.com/space-avionics-defense
Video and Imaging	www.ti.com/video
TI E2E Community	e2e.ti.com