



# PRODUCT DATASHEET

## Sandra series

last update 25/9/2013

### DETAILS

<b>Product Number</b>	C13405_SANDRA-12-M
<b>Family</b>	Sandra
<b>Type</b>	Lens array
<b>Color</b>	clear
<b>Diameter</b>	67 mm
<b>Height</b>	11,1 mm
<b>Style</b>	round
<b>Optic Material</b>	PMMA
<b>Holder Material</b>	
<b>Fastening</b>	pin
<b>Status</b>	ready
<b>ROHS Compliant</b>	Yes
<b>Date Updated</b>	21/10/2013



### OPTICAL PROPERTIES

LED	Viewing Angle	Light Beam	Efficiency	cd/lm	Connector
XT-E	sim: 32	Medium	sim: 92 %	sim: 3.150	-
XP-G2	32 deg	Medium	91 %	2.450	-

H G F E D C B A

4

4

Front view

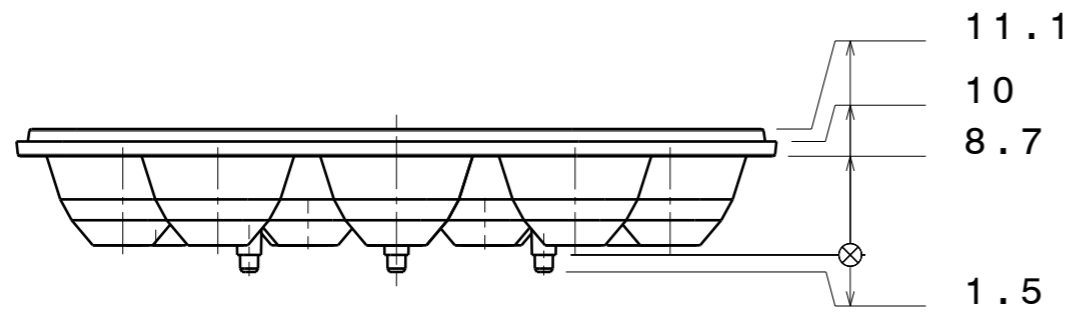

Bottom view

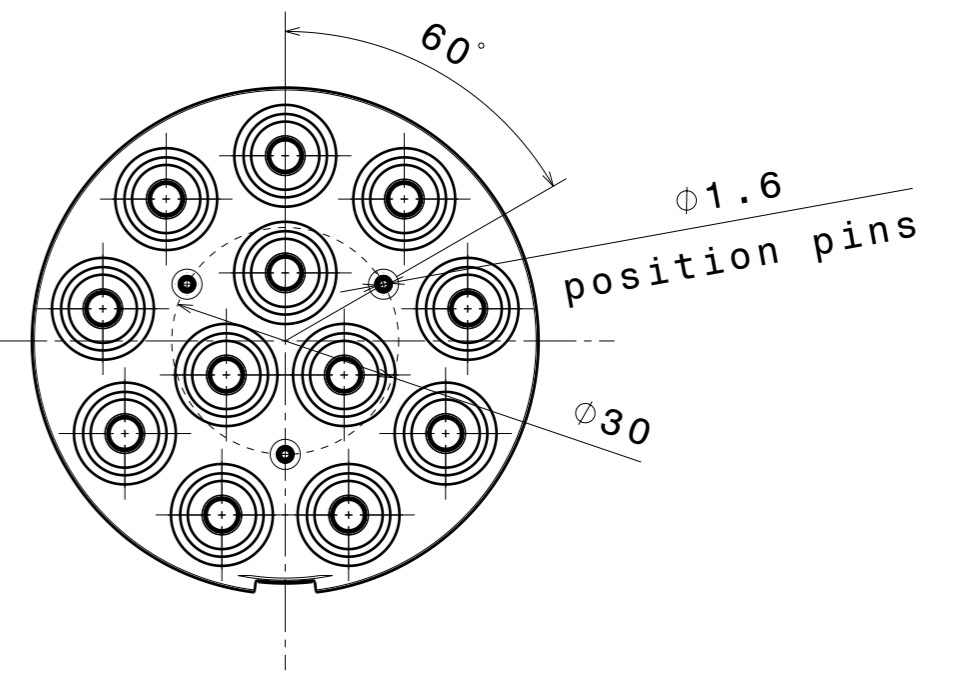

Top view

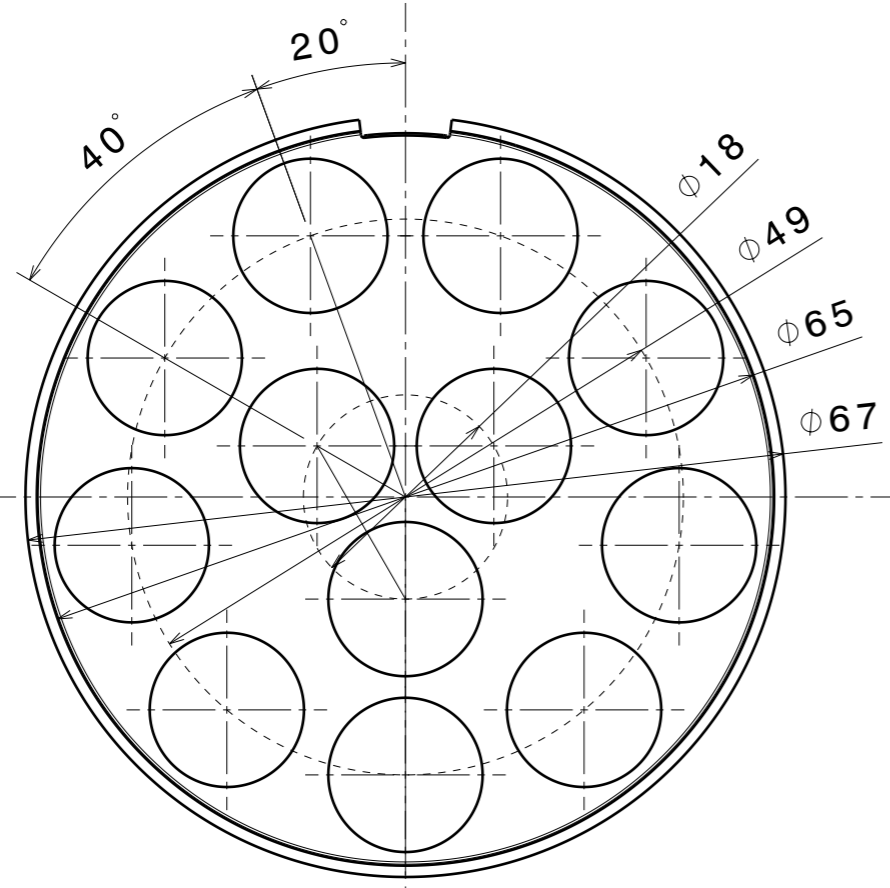

Isometric view

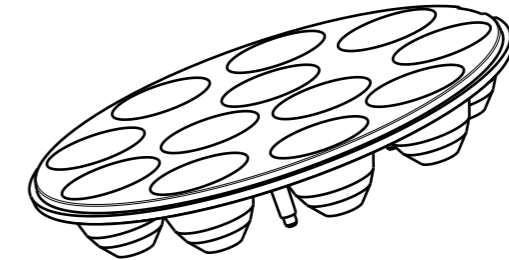

3

3

2

2

1

1

H G F E D C B A

INDEX	PART NO	DESCRIPTION	MATERIAL	COLOUR
1	C13405	SANDRA-12-M	PMMA 8N	

Tolerances if not otherwise shown  
 According to DIN ISO 2768-1  
 Linear measures:  
 Up to 30mm class M, otherwise class C.  
 According to DIN ISO 2768-2  
 Form and position: class L

**LEDiL** LediL Oy  
 Salorankatu 10  
 FIN 24240 SALO  
 Finland

THIRD ANGLE PROJECTION:

DRAWING TITLE  
**C13405\_SANDRA-12-M**

This drawing is the property of LEDiL Oy. It may not be reproduced, copied or communicated without a written agreement with LEDiL Oy."

SIZE	PART NUMBER
<b>A3</b>	<b>C13405</b>

SCALE	1:1	WEIGHT	- g	SHEET	1/1
-------	-----	--------	-----	-------	-----

Luminaire: LEDiL Oy C13405\_SANDRA-12-M\_(XP-G2) Eff.90.7%  
Lamps: 1 x CREE XP-G2 (1256.27lm@250mA)

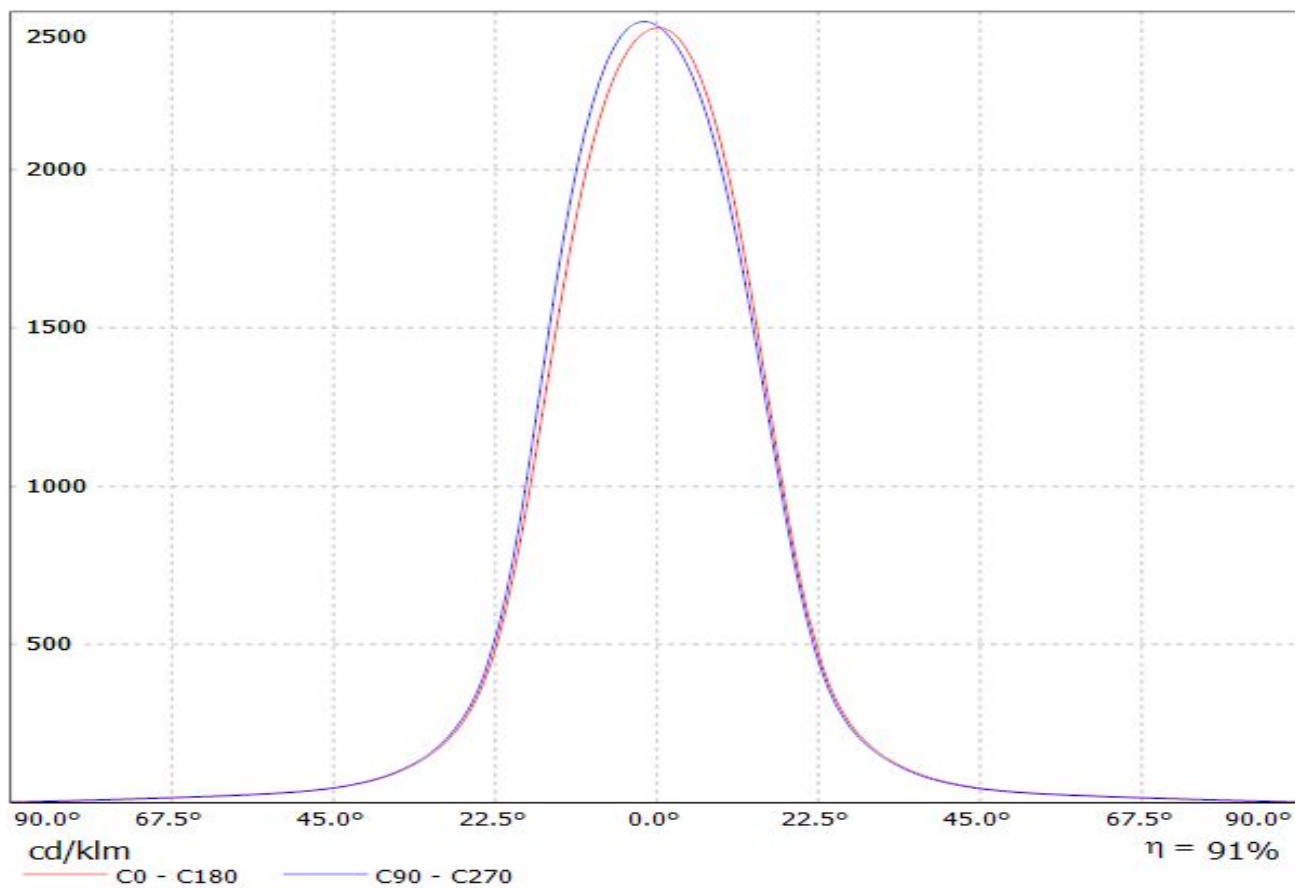

Luminaire: LEDiL Oy C13405\_SANDRA-12-M\_(XP-G2) Eff.90.7%

Lamps: 1 x CREE XP-G2 (1256.27lm@250mA)

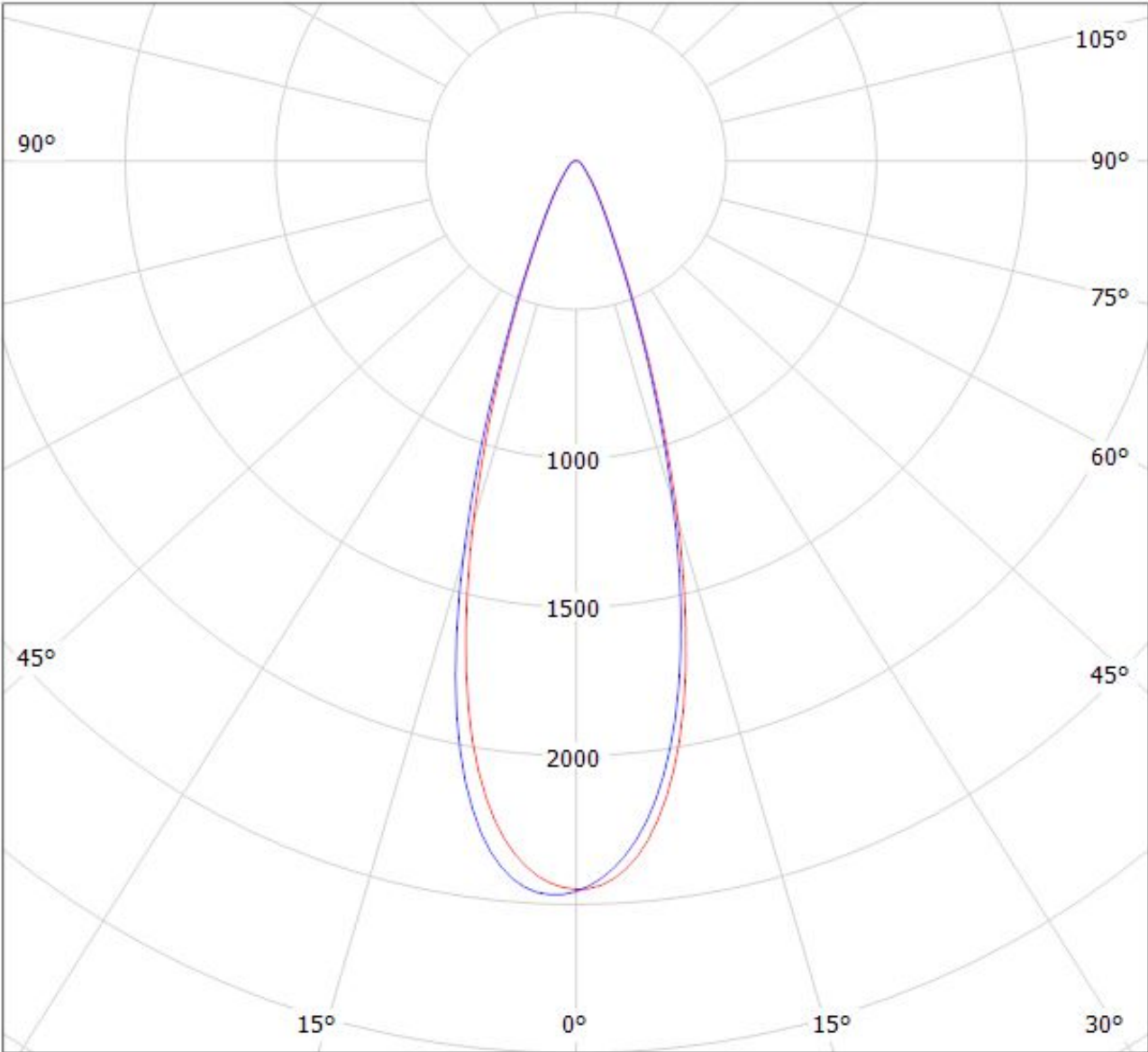

cd/klm

— C0 - C180

— C90 - C270

$\eta = 91\%$

**NOTE: The typical divergence will be changed by different color, chip size and chip position tolerance. The typical total divergence is the full angle measured where the luminous intensity is half of the peak value.**