

Aerospace 30 A - 200 V fast recovery rectifier

Datasheet - production data



Features

- Very small conduction losses
- Negligible switching losses
- High surge current capability
- High avalanche energy capability
- Hermetic package
- Package mass: 10 g
- ESCC qualified

Description

Packaged in an hermetic TO-254 this device is intended for use in medium voltage, high frequency switching mode power supplies, high frequency DC to DC converters, and other aerospace applications.

The complete ESCC specification for this device is available from the European space agency web site. ST guarantees full compliance of qualified parts with such ESCC detailed specifications.

Figure 1. Device configuration

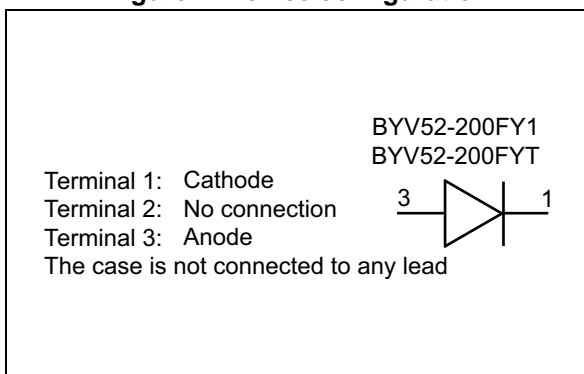

Table 1. Device summary

Order code	ESCC detailed specification	Quality level	Package	EPPL	I _F (AV)	V _{RRM}	T _j (max)	V _F (max)
BYV52-200FY1	-	Engineering model	TO-254	-	30	200	150	1.15
BYV52-200FYT	5103/030/03	ESCC Flight		Yes				

1 Characteristics

Table 2. Absolute maximum ratings

Symbol	Characteristic	Value	Unit
I_{FSM}	Forward surge current (per diode) ⁽¹⁾	400	A
V_{RRM}	Repetitive peak reverse voltage ⁽²⁾	200	V
I_O	Average output rectified current (50% duty cycle): ⁽³⁾	30	A
$I_{F(RMS)}$	Forward rms current (per diode)	30	A
T_{OP}	Operating case temperature range ⁽⁴⁾	-55 to +150	°C
T_J	Junction temperature	+150	°C
T_{STG}	Storage temperature range ⁽⁴⁾	-55 to +150	°C
T_{SOL}	Soldering temperature ⁽⁵⁾	+260	°C

1. Sinusoidal pulse of 10 ms duration
2. Pulsed, duration 5 ms, F = 50 Hz
3. For $T_{case} \geq +120^{\circ}C$, derate linearly to 0 A at +150°C.
4. For devices with hot solder dip lead finish all testing performed at $T_{amb} > +125^{\circ}C$ are carried out in a 100% inert atmosphere.
5. Duration 10 seconds maximum at a distance of not less than 1.5 mm from the device body and the same lead shall not be resoldered until 3 minutes have elapsed.

Table 3. Thermal resistance

Symbol	Parameter	Value	Unit
$R_{th(j-c)}$	Junction to case ⁽¹⁾	0.9	°C/W

1. Package mounted on infinite heatsink.

Table 4. Electrical measurements at ambient temperature (per diode), $T_{amb} = 22 \pm 3 \text{ }^\circ\text{C}$

Symbol	Characteristic	MIL-STD-750 test method	Test conditions	Limits		Units
				Min.	Max.	
I_R	Reverse current	4016	DC method, $V_R = 200 \text{ V}$	-	25	μA
$V_{F1}^{(1)}$	Forward voltage	4011	Pulse method, $I_F = 20 \text{ A}$	-	1.01	V
$V_{F2}^{(1)}$			Pulse method, $I_F = 30 \text{ A}$	-	1.15	V
V_{BR}	Breakdown voltage	4021	$I_R = 100 \mu\text{A}$	200	-	V
C	Capacitance	4001	$V_R = 10 \text{ V}$, $F = 1 \text{ MHz}$	-	400	pF
t_{rr}	Reverse recovery time	4031	$I_F = 1 \text{ A}$, $V_R = 30 \text{ V}$, $di_F/dt = -50 \text{ A}/\mu\text{s}$	-	55	ns
$Z_{th(j-c)}^{(2)}$	Relative thermal impedance, junction to case	3101	$I_H = 15 \text{ to } 40 \text{ A}$, $t_H = 50 \text{ ms}$ $I_M = 50 \text{ mA}$, $t_{md} = 100 \mu\text{s}$	Calculate $\Delta V_F^{(3)}$		$^\circ\text{C}/\text{W}$

1. Pulse width $\leq 300\mu\text{s}$, duty cycle $\leq 2\%$
2. Performed only during screening tests parameter drift values (initial measurements for HTRB), go-no-go.
3. The limits for ΔV_F shall be defined by the manufacturer on every lot in accordance with MIL-STD-750 Method 3101 and shall guarantee the $R_{th(j-c)}$ limits specified in maximum ratings.

Table 5. Electrical measurements at high and low temperatures (per diode)

Symbol	Characteristic	MIL-STD-750 test method	Test conditions ⁽¹⁾	Limits		Units
				Min.	Max.	
I_R	Reverse current	4016	$T_{case} = +125 (+0, -5) \text{ }^\circ\text{C}$ DC method, $V_R = 200 \text{ V}$	-	15	mA
$V_{F2}^{(2)}$	Forward voltage	4011	$T_{case} = +125 (+0, -5) \text{ }^\circ\text{C}$ pulse method, $I_F = 20 \text{ A}$	-	0.95	V
			$T_{case} = +55 (+0, -5) \text{ }^\circ\text{C}$ pulse method, $I_F = 20 \text{ A}$	-	1.15	V

1. Read and record measurements shall be performed on a sample of 5 components with 0 failures allowed. Alternatively a 100% inspection may be performed.
2. Pulse width $\leq 300\mu\text{s}$, duty cycle $\leq 2\%$

To evaluate the conduction losses use the following equation:

$$P = 0.74 \times I_{F(AV)} + 1.00 \times I_{F(RMS)}^2$$

2 Package information

In order to meet environmental requirements, ST offers these devices in different grades of ECOPACK[®] packages, depending on their level of environmental compliance. ECOPACK[®] specifications, grade definitions and product status are available at: www.st.com. ECOPACK[®] is an ST trademark.

2.1 TO-254 information

Figure 2. TO-254^(a) package outline

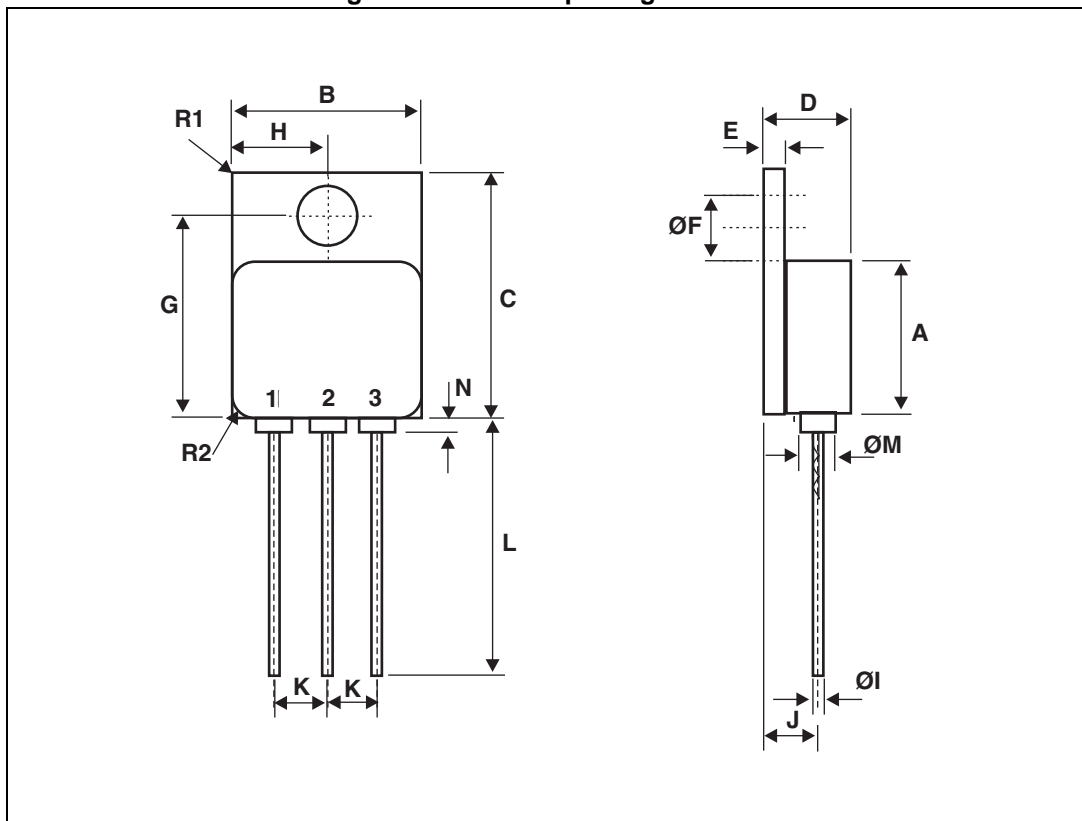

a. The terminal identification is specified by the device configuration. See [Figure 1](#) for terminal connections

Table 6. TO-254 package mechanical data

Reference	Dimension in millimeters		Dimension in inches	
	Min.	Max.	Min.	Max.
A	13.59	13.84	0.535	0.545
B	13.59	13.84	0.535	0.545
C	20.07	20.32	0.790	0.800
D	6.3	6.7	0.248	0.264
E	1	3.9	0.039	0.154
ØF	3.5	3.9	0.138	0.154
G	16.89	17.4	0.665	0.685
H	6.86 BSC		0.270 BSC	
ØI ⁽¹⁾	0.89	1.14	0.035	0.045
J	3.81 BSC		0.150 BSC	
K	3.81 BSC		0.150 BSC	
L	12.95	14.5	0.510	0.571
ØM	3.05 Typ.		0.120 Typ.	
N	-	0.71	-	0.028
R1 ⁽²⁾	-	1	-	0.039
R2 ⁽³⁾	1.65 Typ.		0.065	

1. 3 locations
2. Radius of heatsink flange corner - 4 locations
3. Radius of body corner - 4 locations

3 Ordering information

Table 7. Ordering information⁽¹⁾

Order code	ESCC detailed specification	Package	Lead finish	Comment	Marking	Mass	EPPL	Packing
BYV52-200FY1		TO-254	Gold	Single die	BYV52200FY1 + BeO	10 g		Strip pack
BYV52-200FYT	5103/030/03		Solder dip		510303003+ BeO		Y	

1. Contact ST sales office for information about the specific conditions for products in die form.

4 Revision history

Table 8. Document revision history

Date	Revision	Changes
14-Apr-2010	1	First issue.
19-Mar-2014	2	Updated Table 1: Device summary and Table 7: Ordering information .
10-Sep-2015	3	Update Features . Reformatted to current standards.

IMPORTANT NOTICE – PLEASE READ CAREFULLY

STMicroelectronics NV and its subsidiaries ("ST") reserve the right to make changes, corrections, enhancements, modifications, and improvements to ST products and/or to this document at any time without notice. Purchasers should obtain the latest relevant information on ST products before placing orders. ST products are sold pursuant to ST's terms and conditions of sale in place at the time of order acknowledgement.

Purchasers are solely responsible for the choice, selection, and use of ST products and ST assumes no liability for application assistance or the design of Purchasers' products.

No license, express or implied, to any intellectual property right is granted by ST herein.

Resale of ST products with provisions different from the information set forth herein shall void any warranty granted by ST for such product.

ST and the ST logo are trademarks of ST. All other product or service names are the property of their respective owners.

Information in this document supersedes and replaces information previously supplied in any prior versions of this document.

© 2015 STMicroelectronics – All rights reserved