

Bridgelux[®] Vesta[®] Flex Dual Channel 30W Driver

Product Data Sheet DS 451

PRELIMINARY



Introduction

Dual Channel 30W Driver



The Bridgelux Vesta® Flex Dual Channel 30W Driver enables control of correlated color temperature (CCT) tunable and intensity-dimmable LED sources. A high resolution dimming and tuning algorithm provides smooth, flicker free CCT tuning, dimming to 0.1% and dim-to-off. The Driver's dual channel output integrates seamlessly with Bridgelux Vesta Series Tunable White arrays and linear modules, and the unique design makes it ideal for commercial troffer and linear lighting applications.

Vesta Flex control modules connect to the Driver via the RJ45 control port. Multiple wired and wireless control options enable application flexibility and interoperability with a variety of industry standard lighting devices, controls and third-party systems. Control applications for light provisioning, commissioning and management of large installations are available for the wireless control modules in iOS and Android.

The Vesta Flex Driver platform, in combination with the Vesta Tunable White Array and Linear products, is a bundled system that is guaranteed to work out-of-the-box, shorten design time and reduce project cost.

Features

- 120-277VAC/50-60Hz universal input voltage, low in-rush currents, high efficiencies, low THD, high power factors
- NFC port allows setting of maximum drive current and dimming curve shapes
- Maximum 1.4A drive current per channel, programmable via a NFC interface.
- Linear, square and logarithmic intensity dimming profiles, programmable via an NFC interface
- Each channel is dimmable to 0.1%, dim to off
- RJ45 port connects with all Vesta Flex control modules, provides intensity dimming and CCT tuning input
- Auto-detect of Vesta Flex control module protocol
- Built-in overvoltage, over-temperature and short circuit protection
- Side and bottom feed poke-in connector terminals
- Strain relief and stud mounting options
- 50,000 hour design life with 5-year limited warranty

Benefits

- Compatible with industry standard electrical specification requirements
- Optimized for operation with Bridgelux Vesta® Tunable White arrays and modules
- Smooth, flicker free dimming and CCT tuning
- Dimming curve options to match preference and industry control standards
- Interoperable with a large ecosystem of BLE mesh, Wi-Fi, DALI DT8 and 0-10V devices and controls
- Light provisioning, commissioning and management for wireless controls via parter application, iOS, Android
- SKU reduction for lighting manufacturer
- Multiple mounting options
- Reliable, maintenance-free operation in demanding operating conditions over long periods of time



Contents

Product Feature Map	2
Product Nomenclature, Product Selection Guide	2
Electrical Characteristics	3 - 4
Flicker Characteristics	4
NFC Programming	5
Intensity and CCT Tuning Characteristics	6
Terminal Configuration	7
Mechanical Characteristics	
Environmental and Regulatory Standards	10
Packaging and Labeling	11 - 13
Design Resources	14
Precautions	14
Disclaimers	14
About Bridgelux	15

Product Feature Map

Bridgelux Vesta Flex Dual Channel 30W Driver provides two dynamic constant current outputs for dual channel CCT tunable LED modules and arrays. This Driver interoperates with industry standard lighting systems and protocols and allows for simple integration of Vesta Flex Tunable White Arrays and Linear modules. Please visit www.bridgelux.com for more information.

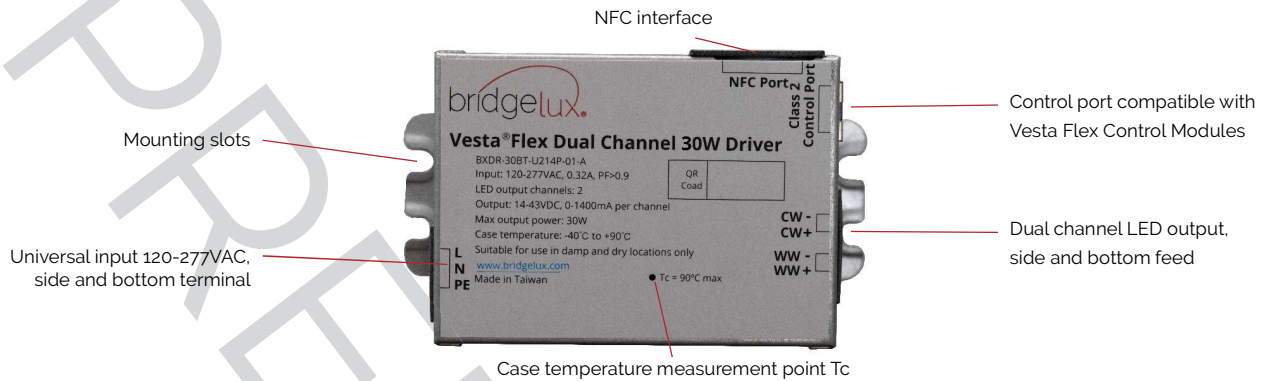

Product Nomenclature

The part number designation for Bridgelux Vesta Flex Dual Channel 30W Driver is explained as follows:

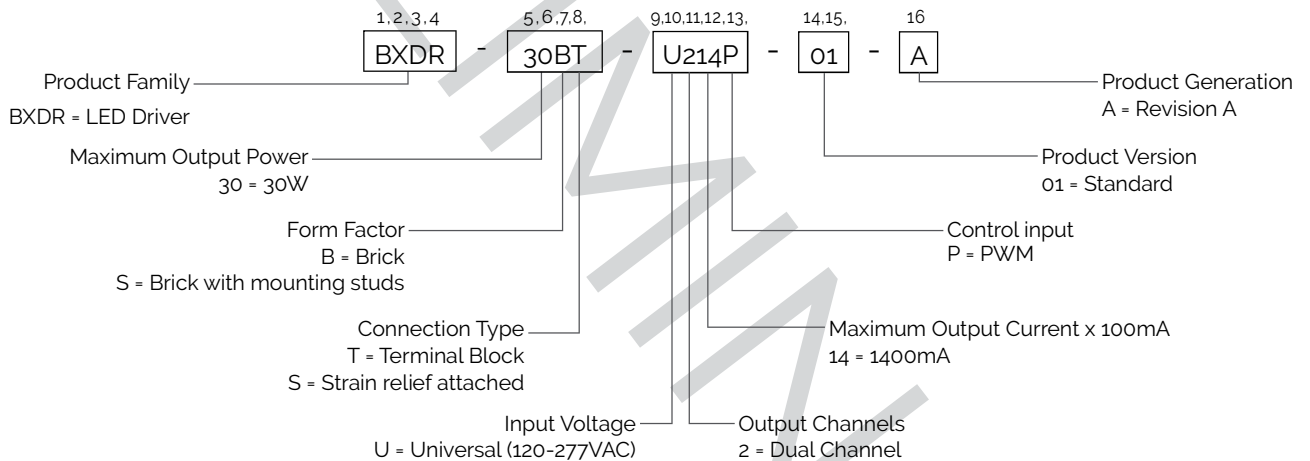

Table 1: Product Selection Guide

Part Number	Configuration
BXDR-30BT-U214P-01-A	Brick
BXDR-30ST-U214P-01-A	Brick with mounting studs
BXDR-30BS-U214P-01-A	Brick with strain relief attached

Electrical Characteristics

Table 2: Electrical Characteristics

Parameter	Specification
Input Voltage	120VAC to 277VAC +/-10%
Input Power	35W (max)
Input Current	0.3A (max)
Inrush Current	Beneath NEMA 410-2011 limit
Surge Protection	6kV per EN 61547: 2009 (IEC 61000-4-5: 2006)
ESD Rating	Class 3B, HBM
Power Factor	>0.9 at 120 to 277VAC (typical, at max load)
Output Power	30W (max)
Output Voltage per Channel	14 - 43V DC
Output Current per Channel ¹	1400mA (max)
Output Current from both Channels combined ¹	1400mA (max)
Output Current Tolerance	+/-5%
Output Current Variation between Channels ²	+/-5%
Startup Time	< 0.5s
Output Ripple	<2% at 120VAC
Minimum Dimming Level	0.1% dim to off
Efficiency ³	>80% at line voltages ranging from 120VAC to 277VAC and loads ranging from 15W to 30W
Total Harmonic Distortion (THD) ³	<20% at line voltages ranging from 120VAC to 277VAC and loads ranging from 15W to 30W
Standby Power ⁴	<0.25W at 120VAC, <0.35W at 220VAC/240VAC and 0.40W at 277VAC
Short Circuit Protection	A short between output terminals results in no output power and an auto reset
Open Circuit Output Voltage	< 60V DC (max)
MTBF	300,000 hrs at T _c = 80°C

Notes for Table 2:

1. The Vesta Flex Dual Channel 30W Driver has two independent output channels, one for cool white and one for warm white. Each channel generates up to 1400mA output current. The maximum combined current from both output channels is also 1400mA. For example, when one channel generates a current of 1000mA, then the other channel is limited to a current of 400mA.
2. The output current variation tolerance between channels applies when both channels are commanded to have an equal output current.
3. For more detail on efficiency and THD, please see Figures 2 and 4.
4. Standby power specifications apply to the driver only when the LEDs are commanded to off and the controls are idling. For standby power specifications of the Vesta Flex Control Modules please refer to their respective data sheets on <https://bridgelux.com>.

Electrical Characteristics

Figure 1: Output Current Operating Range

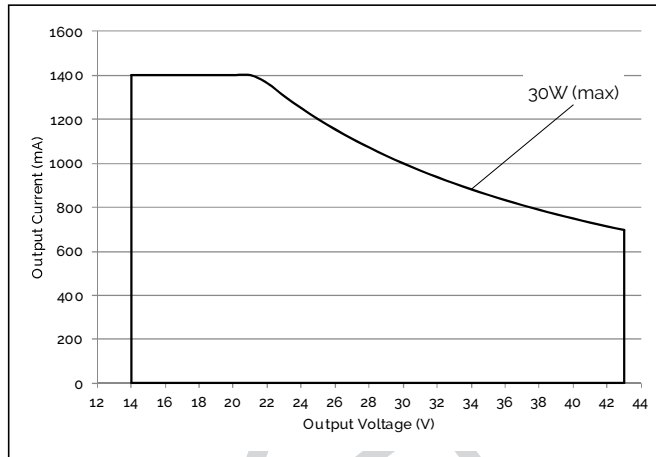

Notes for Figure 1:

1. The Vesta Flex Dual Channel 30W Driver programmable maximum output current is 1400mA. For more information on how to program the maximum output current, please visit the "Driver NFC Programming" section on page 5.

Figure 2: Efficiency vs. Output Power

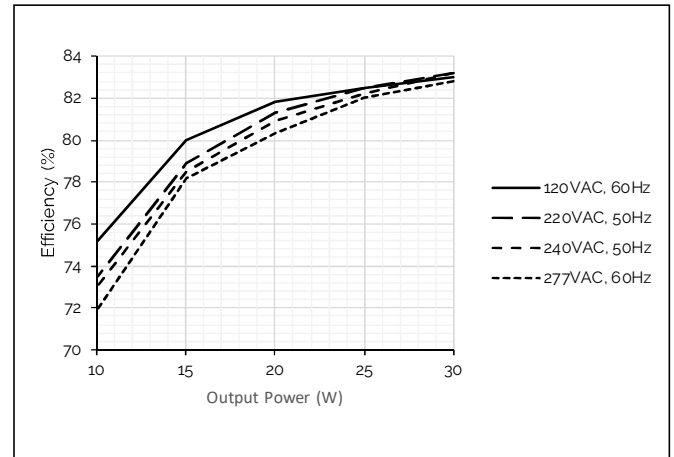

Figure 3: Power Factor vs. Output Power

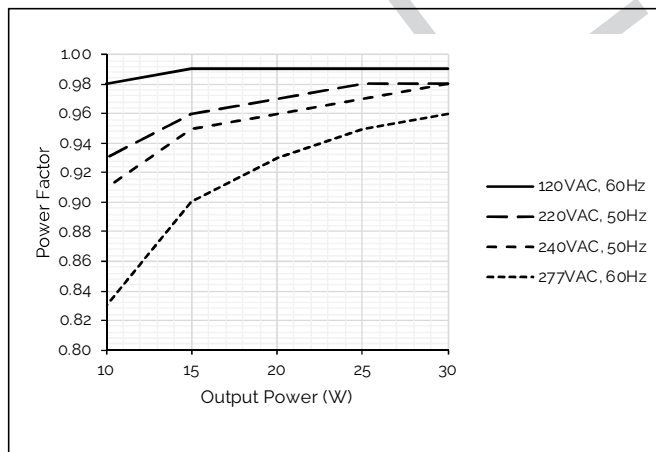
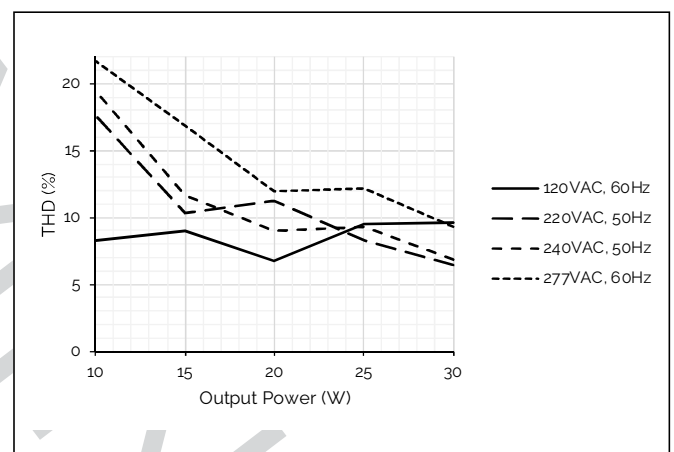

Figure 4: THD vs. Output Power



Note for Figures 2, 3 and 4:

1. Graphs represent typical performance at an ambient temperature of 25°C. The driver was tested with a 30W maximum LED load. Testing at output power levels below the 30W maximum was performed by dimming the light output.

Table 3: Flicker Specifications

Specification	Performance
IEEE P1789	Compliant with "No Effect" Region
NEMA 77-2017	Compliant
CEC Title 24 JA8	Compliant

Driver NFC Programming

The Vesta Flex Dual Channel 30W Driver provides an NFC port, which allows for programming specific driver settings in accordance with customer preferences. The NFC port allows for setting the drivers maximum output current and for selecting a preferred intensity dimming profile. The Driver does not need to be powered when programming these driver settings.

Bridgelux provides NFC tools for programming the Vesta Flex Dual Channel Driver. Alternatively, third-party NFC programming tools compatible with the Vesta Flex NFC port can be used. For more information on Bridgelux's NFC programming tools, please contact your local Bridgelux sales representative.

Table 4: Programmable Maximum Output Current and Dimming Profile

Programming Parameter	Programming Options	Programming Interface
Maximum Combined Output Current	1400mA (default)	NFC port
Dimming Profile	Linear	
	Square (default)	
	Logarithmic	

Notes for Table 4:

- The maximum combined output current can be programmed in 1 mA increments
- The Vesta Flex Dual Channel 30W Driver has two independent output channels, one for cool white and one for warm white. Each channel generates up to 1400mA output current. The maximum combined output current from both output channels is also 1400mA. Once a maximum combined output current has been set via the NFC port, this maximum current will never be exceeded when commanded to maximum brightness via a Vesta Flex Control Module. The maximum combined output current settings can only be changed via the NFC port.
- Examples:
 - If the maximum combined output current is set to 1400mA and one channel generates a current of 1400mA, then the other channel is limited to a current of 0mA.
 - If the maximum combined output current is set to 1400mA and one channel generates a current of 1000mA, then the other channel is limited to a current of 400mA.
 - If the maximum combined output current is set to 1000mA and one channel generates a current of 700mA, then the other channel is limited to a current of 300mA.

Intensity Dimming and CCT Tuning Characteristics

Figure 5: Intensity Dimming Profile Characteristics

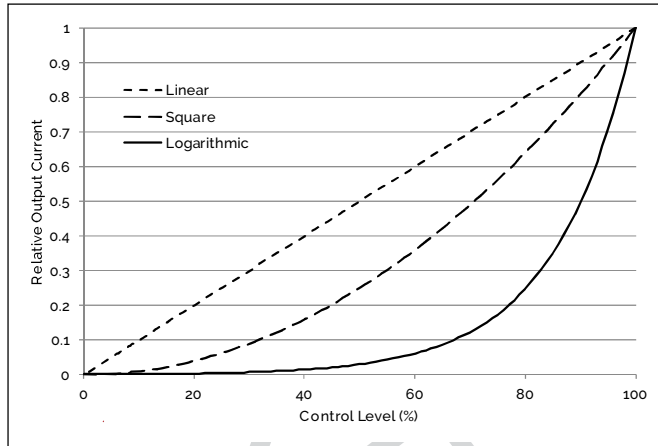

Figure 6: CCT Tuning Characteristics

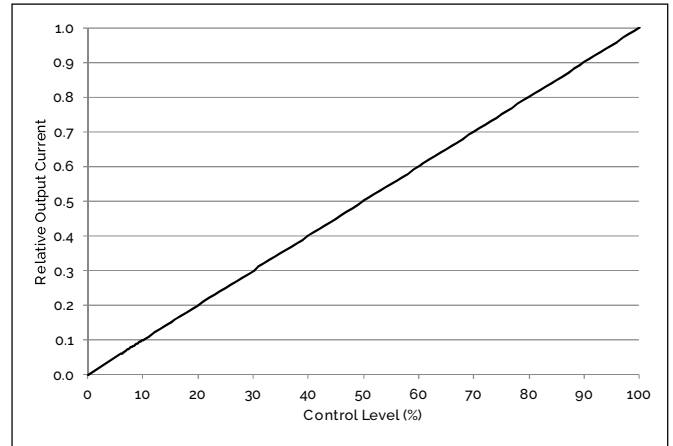
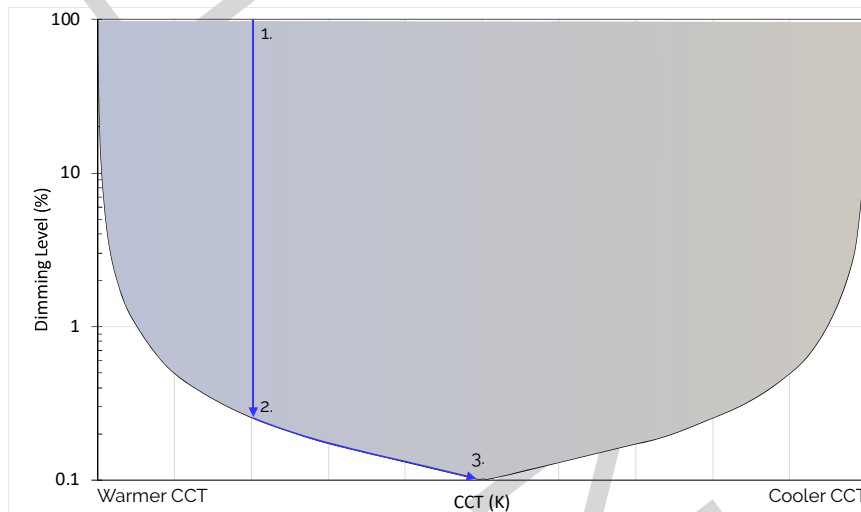

Figure 7: CCT Tuning Operating Range



Notes for Figure 7:

1. This graph represents the CCT tuning characteristics over the dimming range of the driver. The area on and above the graph represent possible CCT tuning and dimming combinations. Any CCT and dimming combinations below the graph are unattainable.
2. When dimming brightness at a set CCT (1) and the dimming level reaches the minimum dimming level at the set CCT (2), then the CCT will shift and follow the graph until the dimming level reaches 0.1% (3).
3. Below the 0.1% dimming level, the Driver dims-to-off and the current in both channels goes to 0mA.

Connector Configuration

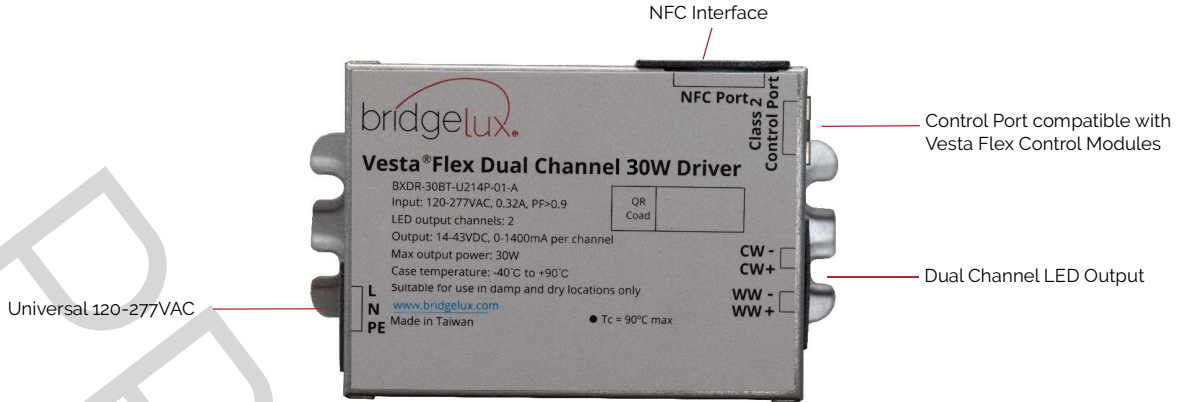

Table 5: Connector Configuration

Feature	Universal 120 - 277VAC Terminal	Dual Channel LED Output	Control Port
Connector Type	Poke-In Terminal Block with Release	Poke-In Terminal Block with Release	RJ45 Terminal Block
AWG Wire Size	20-24 (Beta Samples) 18-22 (Production Parts)	20 - 24	n.a.
Wire Type ¹	Solid Core, Stranded or Stranded Tinned	Solid Core, Stranded or Stranded Tinned	Cat cable as defined by TIA/EIA-568
Wire Strip Length	9mm +/-1mm	9mm +/-1mm	n.a.

Note for Table 5:

1. Connecting stranded or stranded tinned wires may requires the use of a release tool for the poke-in terminal block. Alternatively a 2mm flathead screw driver may be used to release the poke in connectors.

Control port connection

Vesta Flex Dual Channel Drivers are designed to connect with all Vesta Flex Control Modules out-of-the-box. Any 8P8C category ethernet cable with RJ45 connectors may be used to connect the driver and the control module via their RJ45 ports. The communication between the Driver and the Control Module takes place via a dual channel PWM signal. The Vesta Flex Dual Channel 60W Driver will not work without this PWM signal provided by a Vesta Flex Control Module. Vesta Flex Control Modules are available in a variety of wired and wireless control protocols, including BLE-mesh, Wi-Fi, DALI and 0-10V.

Although the Vesta Flex Dual Channel Driver and Vesta Flex Control Modules can be connected by any 8P8C category Ethernet cable with a RJ45 connector, Bridgelux recommends the use of an Ethernet cable that is commonly available and recognized by the TIA (Telecommunications Industries Association), including Cat5e, Cat6 and Cat6a cables. The maximum length of the Ethernet cable should not exceed 300m to guarantee reliable signal transmission.

The maximum number of Vesta Flex Dual Channel Drivers that can be connected to a single Vesta Flex Control Module is 5.

Mechanical Characteristics

Table 6: Driver Mechanical Characteristics

Properties	Specification
Dimensions (without mounting studs)	104mm (L) x 76mm (W) x 25mm (H)
Enclosure Material ¹	Metal
Weight	385 grams
Ingress Protection	IP20

Note for Table 6:

1. The driver is fully potted to provide protection and a thermal path for its electronic components and circuitry

Figure 8: Mechanical Drawing

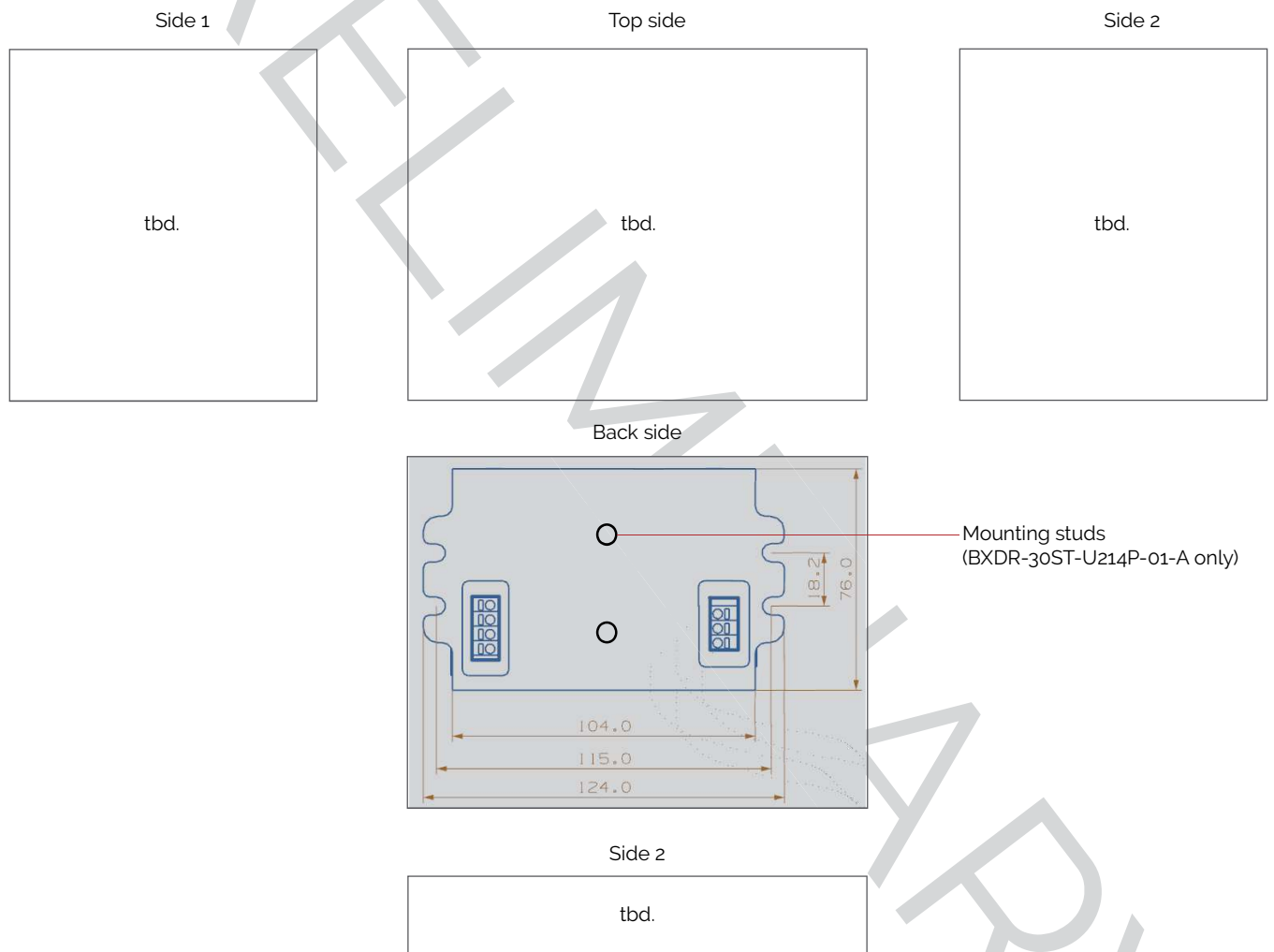

Notes for Figure 8:

1. Drawings are not to scale
2. Drawing dimensions are in millimeters
3. Unless otherwise specified, all linear tolerances are +/-1.0mm
4. Use #10 or M5 fastener in the mounting slots for anchoring the driver in position
5. Use #8 nut on mounting studs for fastening driver in position (BXDR-30ST-U214P-01-A only)

Mechanical Characteristics

Table 7: Driver With Strain Relief Mechanical Characteristics

Properties	Specification
Dimensions	164.2 mm (L) x 81.9 mm (W) x 24.5 mm (H)
Enclosure Material ¹	Metal (driver), Plastic (strain relief)
Weight	tbd. grams
Ingress Protection	IP20

Note for Table 7:

1. The driver is fully potted to provide protection and a thermal path for its electronic components and circuitry

Figure 9: Mechanical Drawing

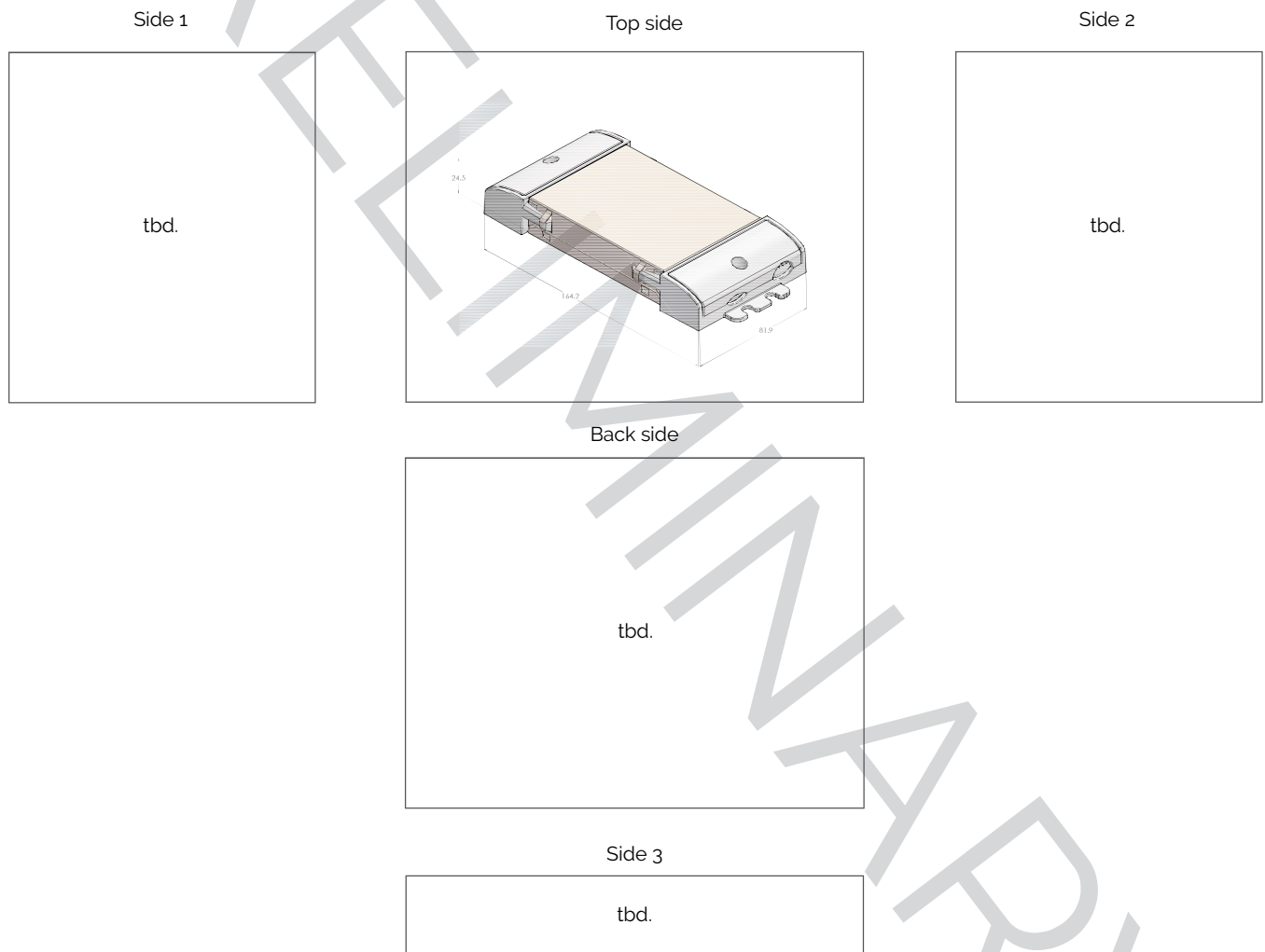

Notes for Figure 9:

1. Drawings are not to scale
2. Drawing dimensions are in millimeters
3. Unless otherwise specified, all linear tolerances are +/-1.0mm
4. Use #10 or M5 fastener in the mounting slots for anchoring the driver in position

Environmental and Regulatory Standards

Table 8: Environmental Conditions

Parameter	Specification
Case Temperature, Tc	+90 C (max)
Ambient Operating Temperature	-40 C to +60 C
Humidity Ratings	Maximum 85% Relative Humidity, non condensing
Operating Environment	For indoor use only
Storage Temperature	-20 C to +70 C
Over-Temperature Protection ¹	80% of commanded output current at case temperature Tc ≥ +90C
	Zero output current at case temperature Tc ≥ +110C
	100% of commanded output current at case temperature Tc ≤ 85C (auto recovery)

Notes for Table 8:

1. The Over-Temperature Protection feature provides for a 10s fade time when transitioning from one condition to another

Table 9: Regulatory Approvals and Compliance

Specification	Description
UL 8750, rated for dry and damp locations, (Class 2)	UL safety standard for Light Emitting Diode (LED) equipment for use in lighting products
Category FKSZ/7, file number E506581, (Class P)	UL evaluation and testing guidelines for standardized LED driver constructions and ratings
EN 61347-2-13:2014 + A1:2017, (CE, ENEC)	IEC specification that specifies particular safety requirements for electronic controlgear for use on D.C. or A.C. supplies in lighting applications
EN 55015:2013	Limits and methods of measurement of radio disturbance characteristics of electrical lighting and similar equipment
EN 61547:2009	International Standard for electromagnetic immunity requirements applicable to lighting equipment
EN 61000-3-2:2013	Electromagnetic compatibility (EMC). Limits of voltage changes, voltage fluctuations and flicker in low-voltage supply systems
EN 61000-3-2:2014	Limitation of harmonic currents injected into the public supply system
IEC 60950-1	Standard for power supplies meeting the Safety Extra Low Voltage (SELV) specification
RoHS 3	Restriction of Hazardous Substances directive

Packaging for brick driver

Table 10: Packaging Configuration

	Tray	Box	Pallet
Quantity	tbd.	tbd.	tbd.
Weight	tbd.	tbd.	tbd.

Figure 10: Tray Design

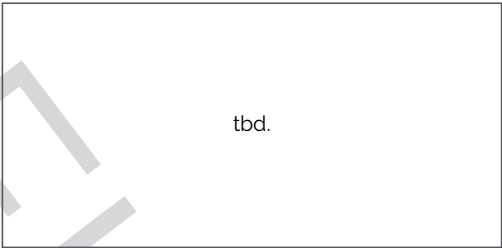

Figure 11: Packaging Box Design



Packaging for brick driver with mounting studs

Table 11: Packaging Configuration

	Tray	Box	Pallet
Quantity	tbd.	tbd.	tbd.
Weight	tbd.	tbd.	tbd.

Figure 12: Tray Design

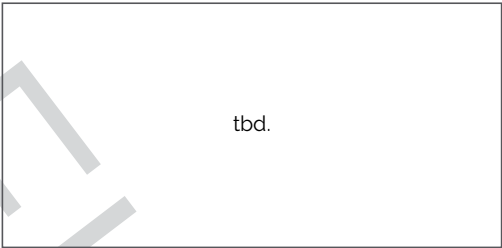

Figure 13: Packaging Box Design



Packaging for brick driver with strain relief

Table 12: Packaging Configuration

	Tray	Box	Pallet
Quantity	tbd.	tbd.	tbd.
Weight	tbd.	tbd.	tbd.

Figure 14: Tray Design

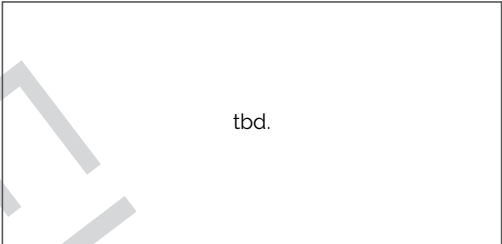

Figure 15: Packaging Box Design



Design Resources

Application Notes

Please contact your Bridgelux sales representative for assistance on obtaining application support when designing with the Bridgelux Vesta Flex Dual Channel Driver. For a list of available resources, visit www.bridgelux.com.

3D CAD Models

CAD models depicting the Vesta Flex Dual Channel Driver are available in both IGES and STEP formats. Please contact your Bridgelux sales representative for assistance.

Precautions

CAUTION: PRODUCT HANDLING

Handle the Vesta Flex Dual Channel Driver with care to prevent any damage from mechanical shock

It is recommended to handle this driver in a static-free environment

Do not open or disassemble the product

To maintain product warranty, the installer is responsible for ensuring that the driver's operating conditions do not exceed the maximum conditions stated within this data sheet

CAUTION: PRODUCT INSTALLATION

Incorrect installation of the Vesta Flex Dual Channel Driver can cause irreparable damage to the driver, connected LEDs or connected Vesta Flex control modules.

Pay attention when connecting the LED load and observe the correct polarity of the output terminals as specified in this data sheet and on the driver label.

WARNING: ELECTRIC SHOCK

Be aware of the possibility of an electric shock hazard which can result in serious injury or death. Disconnect power before servicing or installing this device.

Disclaimers

MINOR PRODUCT CHANGE POLICY

The rigorous qualification testing on products offered by Bridgelux provides performance assurance. Slight cosmetic changes that do not affect form, fit, or function may occur as Bridgelux continues product optimization.

About Bridgelux: Bridging Light and Life™

At Bridgelux, we help companies, industries and people experience the power and possibility of light. Since 2002, we've designed LED solutions that are high performing, energy efficient, cost effective and easy to integrate. Our focus is on light's impact on human behavior, delivering products that create better environments, experiences and returns—both experiential and financial. And our patented technology drives new platforms for commercial and industrial luminaires.

For more information about the company, please visit
bridgelux.com
twitter.com/Bridgelux
facebook.com/Bridgelux
youtube.com/user/Bridgelux
linkedin.com/company/bridgelux-inc-_2
WeChat ID: BridgeluxInChina



46430 Fremont Blvd
Fremont, CA 94538 USA
Tel (925) 583-8400
www.bridgelux.com

© 2019 Bridgelux, Inc. All rights reserved 2019. Product specifications are subject to change without notice. Bridgelux, the Bridgelux stylized logo design and Vesta are registered trademarks of Bridgelux, Inc. Bridging Light and Life is a trademark of Bridgelux, Inc. All other trademarks are the property of their respective owners.

Bridgelux Vesta Flex Dual Channel 30W Driver Data Sheet DS451 Rev. A PRELIMINARY (10/2019)