

isc Silicon NPN Power Transistor

BUL1203E

DESCRIPTION

- High Voltage
- High Speed Switching

APPLICATIONS

- Electronic ballasts for fluorescent lighting

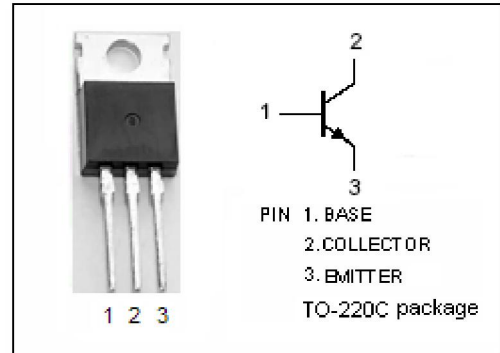

ABSOLUTE MAXIMUM RATINGS (T_a=25°C)

SYMBOL	PARAMETER	VALUE	UNIT
V _{CBO}	Collector-Base Voltage	1200	V
V _{CES}	Collector-Emitter Voltage V _{BE} = 0	1200	V
V _{CEO}	Collector-Emitter Voltage	550	V
V _{EBO}	Emitter-Base Voltage	9	V
I _C	Collector Current-Continuous	5	A
I _{CM}	Collector Current-Peak	8	A
I _B	Base Current	2	A
I _{BM}	Base Current-Peak	4	A
P _C	Collector Power Dissipation @T _C =25°C	100	W
T _J	Junction Temperature	150	°C
T _{stg}	Storage Temperature Range	-65~150	°C

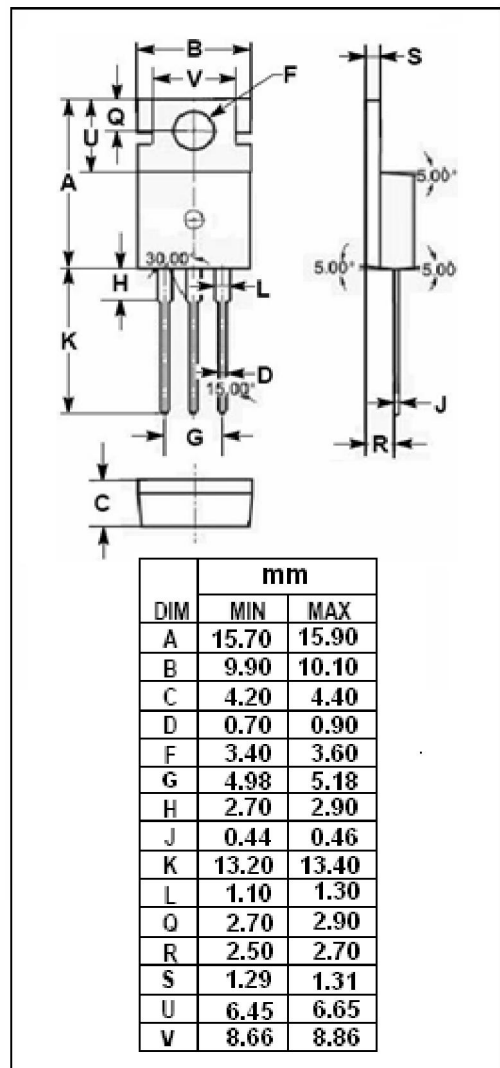

THERMAL CHARACTERISTICS

SYMBOL	PARAMETER	MAX	UNIT
R _{th j-c}	Thermal Resistance, Junction to Case	1.25	°C/W

isc Silicon NPN Power Transistor

BUL1203E

ELECTRICAL CHARACTERISTICS

 $T_C=25^{\circ}\text{C}$ unless otherwise specified

SYMBOL	PARAMETER	CONDITIONS	MIN	TYP.	MAX	UNIT
$V_{CEO(SUS)}$	Collector-Emitter Sustaining Voltage	$I_C=0.1\text{A}; I_B=0, L=25\text{mH}$	550			V
$V_{CE(sat)-1}$	Collector-Emitter Saturation Voltage	$I_C=1\text{A}; I_B=0.2\text{A}$			0.5	V
$V_{CE(sat)-2}$	Collector-Emitter Saturation Voltage	$I_C=2\text{A}; I_B=0.4\text{A}$			0.7	V
$V_{CE(sat)-3}$	Collector-Emitter Saturation Voltage	$I_C=3\text{A}; I_B=1\text{A}$			1.5	V
$V_{BE(sat)-1}$	Base-Emitter Saturation Voltage	$I_C=2\text{A}; I_B=0.4\text{A}$			1.5	V
$V_{BE(sat)-2}$	Base-Emitter Saturation Voltage	$I_C=3\text{A}; I_B=1\text{A}$			1.5	V
I_{CES}	Collector Cutoff Current	$V_{CE}=1200\text{V}; V_{BE}=0$			0.1	mA
I_{CEO}	Collector Cutoff Current	$V_{CE}=550\text{V}; I_B=0$			0.1	mA
h_{FE-1}	DC Current Gain	$I_C=1\text{mA}; V_{CE}=5\text{V}$	10			
h_{FE-2}	DC Current Gain	$I_C=10\text{mA}; V_{CE}=5\text{V}$	10			
h_{FE-3}	DC Current Gain	$I_C=0.8\text{A}; V_{CE}=3\text{V}$	14		32	
h_{FE-4}	DC Current Gain	$I_C=2\text{A}; V_{CE}=5\text{V}$	9		28	

Switching Times ;Resistive Load

t_{on}	Turn-on Time	$I_C=2\text{A}; I_{B1}=0.4\text{A}; I_{B2}=-0.8\text{A};$ $t_p=30\mu\text{s}; V_{CC}=150\text{V}$			0.5	μs
t_s	Storage Time				3.0	μs
t_f	Fall Time				0.3	μs