

BMD-34 EVK

Evaluation kit for BMD-34 series modules

User guide



Abstract

This document describes how to set up the EVK-BMD-340 and EVK-BMD-341 evaluation kits to evaluate BMD-34 series modules. It also describes the different options for debugging and the development capabilities included in the evaluation board.

Document information

Title	BMD-34 EVK	
Subtitle	Evaluation kit for BMD-34 series modules	
Document type	User guide	
Document number	UBX-19033356	
Revision and date	R03	24-Oct-2019
Disclosure restriction		

This document applies to the following products:

Product name	Type number
BMD-340-Eval	BMD-340-Eval-00
BMD-341-Eval	BMD-341-Eval-00

u-blox or third parties may hold intellectual property rights in the products, names, logos and designs included in this document. Copying, reproduction, modification or disclosure to third parties of this document or any part thereof is only permitted with the express written permission of u-blox.

The information contained herein is provided "as is" and u-blox assumes no liability for its use. No warranty, either express or implied, is given, including but not limited to, with respect to the accuracy, correctness, reliability and fitness for a particular purpose of the information. This document may be revised by u-blox at any time without notice. For the most recent documents, visit www.u-blox.com.

Copyright © u-blox AG.

Contents

Document information	2
Contents	3
1 Product description	4
1.1 Key features	4
1.2 Kit includes	5
1.3 Development tools	5
2 Hardware description	6
2.1 Power	6
2.1.1 Powering the board	6
2.1.2 USB peripheral power	7
2.2 Reset.....	7
2.3 Buttons.....	9
2.4 LEDs.....	9
2.5 Virtual COM port	10
2.6 32 kHz crystal oscillator	10
2.7 NFC connector	10
2.8 Current sensing headers	11
2.9 External SEGGER J-Link™ debug interface	11
2.10 QSPI	12
2.11 GPIO jumpers	12
2.12 Header pin-out.....	13
3 Setting up the evaluation board	16
3.1 Set up the tool chain.....	16
3.2 Connect BMD-34 evaluation kit to a computer	16
3.3 Open an example project.....	18
Related documents	19
Revision history	19
Contact	20

1 Product description

The BMD-34-EVAL kits provide stand-alone use of the BMD-340 or BMD-341 module featuring the Nordic nRF52840 RF System on Chip (SoC). Other modules have evaluation kits covered by other documents.

The evaluation kit provides a great starting point for almost any Bluetooth 5 low energy, Thread, or Zigbee project. All features of the BMD-340/341 are easily accessed from the evaluation board. A simple USB connection provides power, programming, and a virtual COM port. Four user buttons are available, as well as a USB peripheral connector, four LEDs and a reset button. All 48 GPIO are available on headers that are compatible with the Arduino® form factor. This allows easy use of any existing Arduino shields. Current sense resistors allow for measuring current into the module and into the shield.

This guide provides setup instructions for starting development and describes the hardware functionality of the BMD-34-EVAL boards.

1.1 Key features

- Used for evaluation of BMD-340 or BMD-341 modules
- On-board programming and debug (SEGGER J-Link-OB)
- Able to program external modules
- Virtual COM port over USB
- Full GPIO of the BMD-34 / nRF52840
- Buttons and LEDs for user interaction
- NFC antenna connector
- 32.768 kHz Crystal
- CR2032 battery holder
- USB peripheral connector
- Power input and mode selections

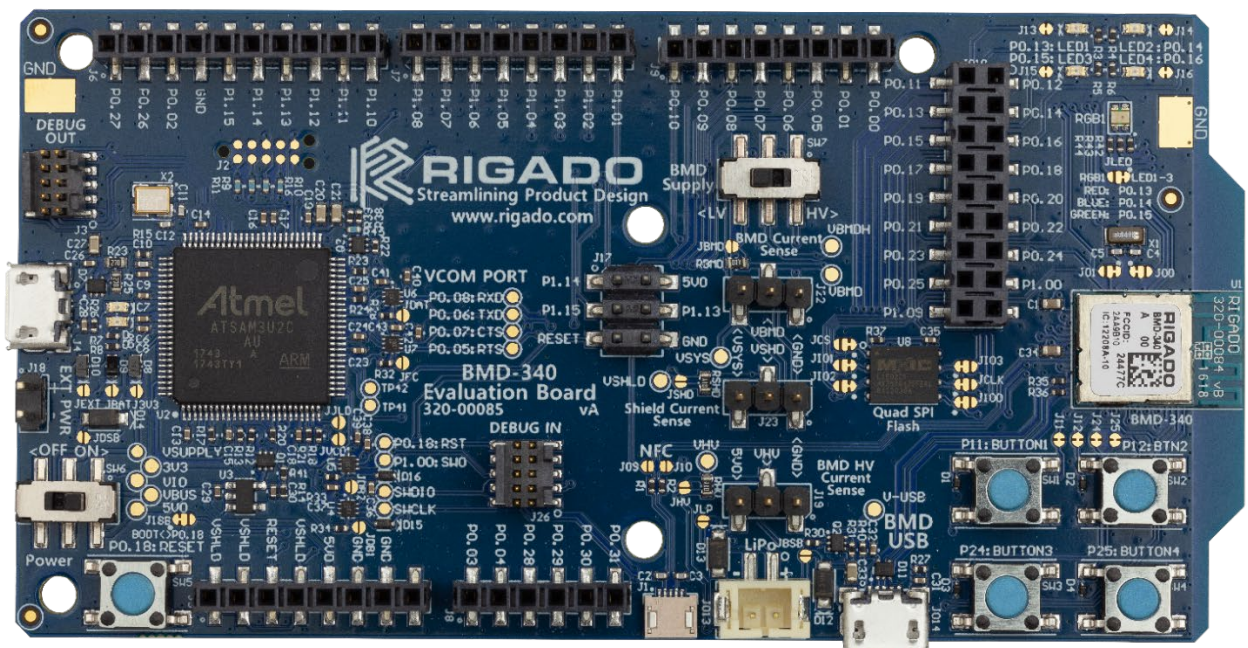

Figure 1: BMD-34 EVK evaluation board (Top view)

1.2 Kit includes

BMD-340 evaluation kit includes:

- BMD-340 evaluation board
- Micro-USB cable
- NFC antenna

BMD-341 evaluation kit includes:

- BMD-341 evaluation board
- Micro-USB cable
- NFC antenna
- 2.4 GHz antenna kit

1.3 Development tools

The tools listed below will aid in development with the BMD-34 series Bluetooth modules. Not all tools will be required depending on which software suite is used.

Tool	Description
SEGGER Embedded Studio	SEGGER Embedded Studio is an easy-to-use integrated development environment with project management tools, editor and debugger supporting ARM Cortex devices. Full debug support including Real Time Terminal (RTT) output is also available. Available for Windows, macOS, and Linux. Free license for use with the Nordic nRF5 ICs and modules: http://license.segger.com/Nordic.cgi
SEGGER J-Link Software and Documentation Pack	J-Link Commander (JLink.exe) is a command line-based utility that can be used for verifying proper functionality of J-Link as well as for simple analysis of the target system. It supports some simple commands, such as memory dump, halt, step, go etc. to verify the target connection. Available for Windows, macOS, and Linux.
Nordic Semiconductor SDK	The nRF5 SDK is your first stop for building fully featured, reliable and secure applications with the nRF52 and nRF51 series. It offers developers a wealth of varied modules and examples right across the spectrum including numerous Bluetooth Low Energy profiles, Device Firmware Upgrade (DFU), GATT serializer and driver support for all peripherals on all nRF5 Series devices. SDKs for Bluetooth Mesh, Thread, Zigbee and other protocols are also available.
Nordic Semiconductor nRF Connect for Desktop	nRF Connect is a cross-platform tool that enables testing and development with Bluetooth® low energy (previously called Bluetooth Smart). It allows easy setup of connections with other devices and uses these connections to read and write the external nodes. Available for Windows, macOS, and Linux.
Nordic Semiconductor nRF Connect for Mobile	nRF Connect for Mobile, previously known as nRF Master Control Panel, is a powerful generic tool that allows you to scan and explore your Bluetooth low energy devices and communicate with them. nRF Connect for Mobile supports several Bluetooth SIG adopted profiles, as well as the Device Firmware Update profile (DFU) from Nordic Semiconductor or Eddystone from Google. Available for iOS and Android.
Nordic Semiconductor Mobile Apps	Additional mobile utilities for your application development. Available for iOS and Android.

Table 1: Useful tools

2 Hardware description

Design files for each of the BMD-3xx evaluation boards may be requested from the [u-blox support team](#).

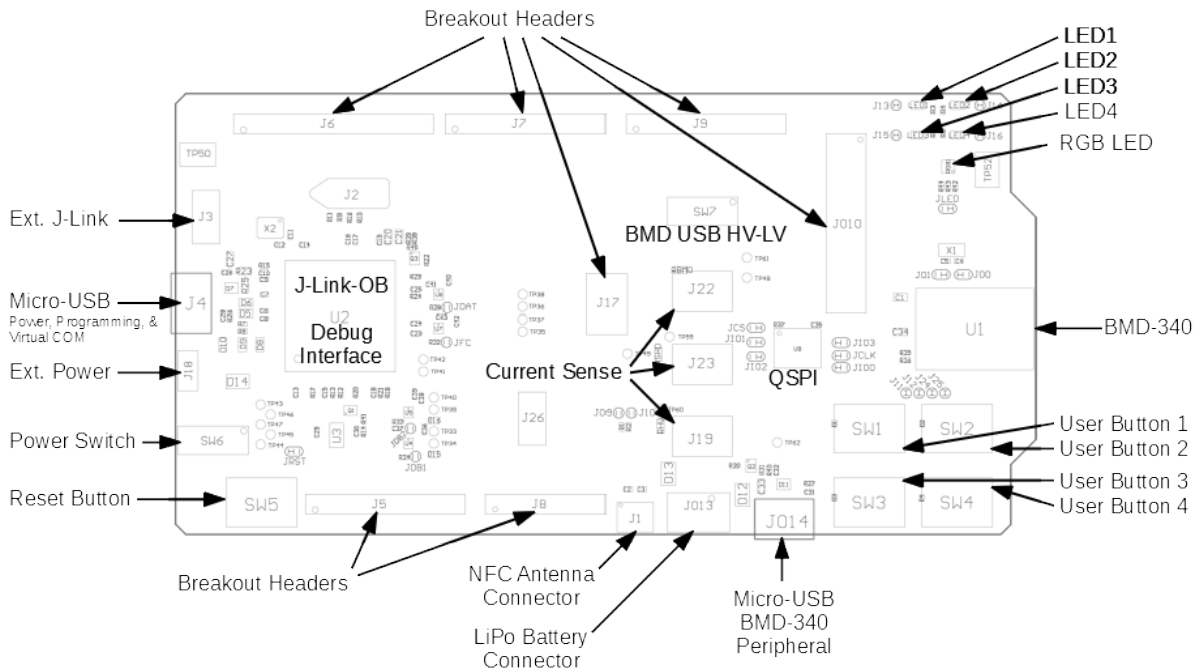

Figure 2: Assembly drawing (Top view)

2.1 Power

The BMD-34 evaluation board has five possible power sources as listed below:

- USB from the debug interface
- USB peripheral on the BMD-340 itself
- CR2032 coin cell battery
- 2.54 mm through-hole connector for connecting 3.3 V
- Lithium Polymer (LiPo) battery input

These power sources use protection diodes to prevent reverse voltage to any supply. This allows them to be used simultaneously. Solder jumpers are provided to allow by-passing any of the protection diodes eliminating the voltage drop across them.

Care should be taken to not damage the supplies when the protection is by-passed.

2.1.1 Powering the board

During typical debugging, power will be provided by VBUS on the USB debug interface to supply 5 V to the 3.3 V LDO regulator and to the shield connector. The 3.3 V LDO regulator will then power VIO, VSHLD, and VBMD.

When powering the board from the CR2032 coin cell (3VDC), the external power header, or the LiPo header, USB can be left disconnected. In this configuration, the interface IC is held in reset to conserve power.

Only if the power protection diodes are left intact, USB can be connected at the same time the coin cell or external power is still applied allowing for easy programming of the module.

2.1.2 USB peripheral power

VBUS Power from the USB Peripheral interface on the BMD-340 may be used to power the BMD-340-EVAL by moving SW7 to the “HV” setting. This enables the internal high-voltage regulator (LDO or DC-DC). When in the HV setting, the power switch SW6 should be left in the OFF position, especially if any of the protection diodes are bypassed.

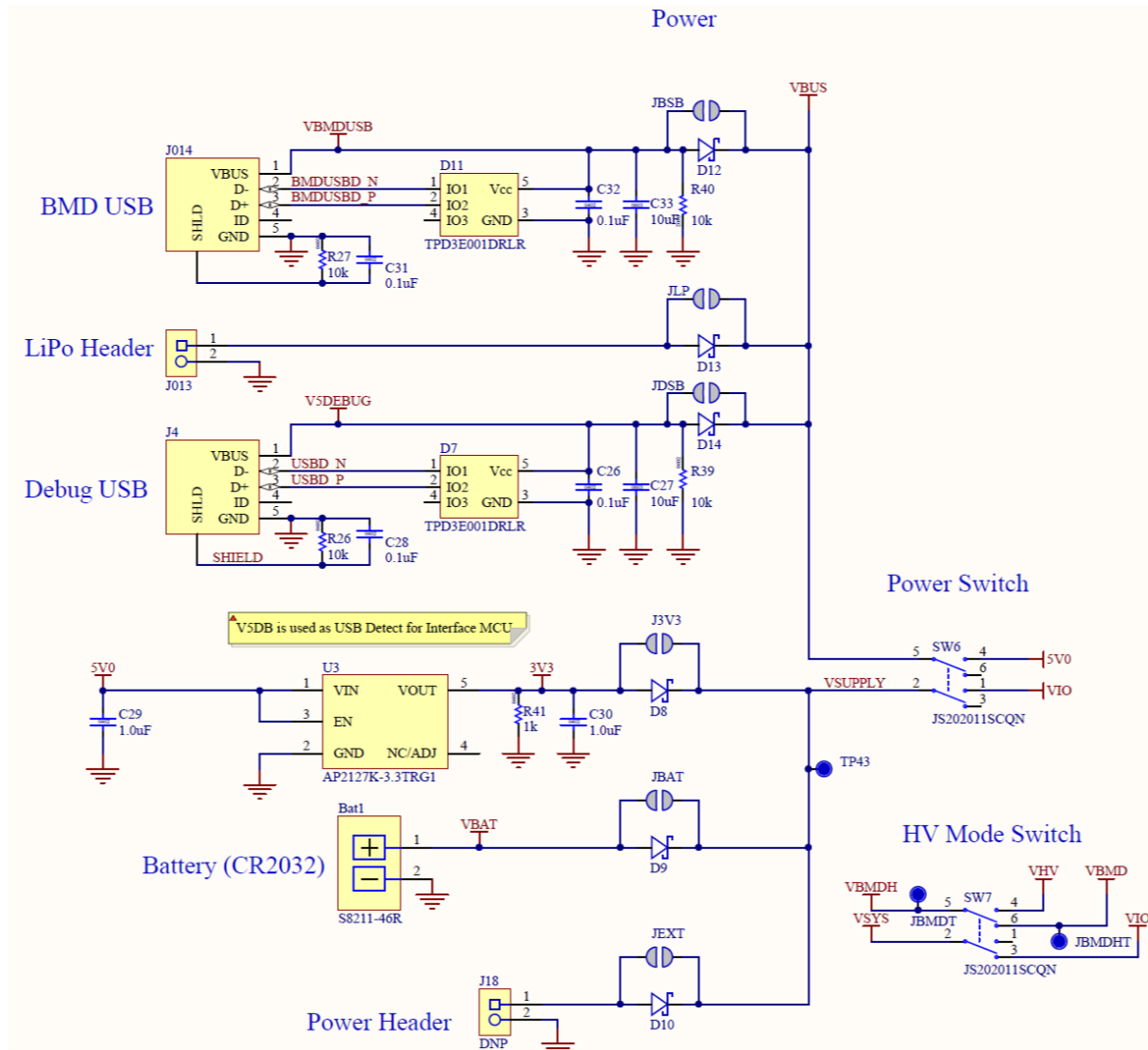

Figure 3: Schematic – Power supply

2.2 Reset

The BMD-34 module has a configurable hardware reset. P0.18 is assumed to be used as the reset pin for all BMD-34 and Nordic example projects, and thus the evaluation board hardware is configured to use P0.18 as a reset. The Reset button can be configured to connect to an input on the interface IC or to directly connect to P0.18.

The reset button is connected to the IC used for the J-Link interface by default. Pressing reset while the interface IC is powered will cause a momentary reset signal on the RESET_N output of the interface IC, which is connected via solder jumper to P0.18 of the BMD-34 module. If the reset button is held down during EVK power on, it will cause the interface IC to enter its bootloader mode, allowing either SEGGER J-Link or mbed programmer firmware to be programmed.

When the reset button is directly connected to P0.18, it can be used as a fifth user button or as a reset button directly connected to the BMD-34 module.

Solder jumper J18 is used to connect P0.18 of the BMD-34 module to the RESET_N net (noted as nRESET in Figure 4 below). RESET_N is connected to the interface IC and to the reset connections on the Arduino headers.

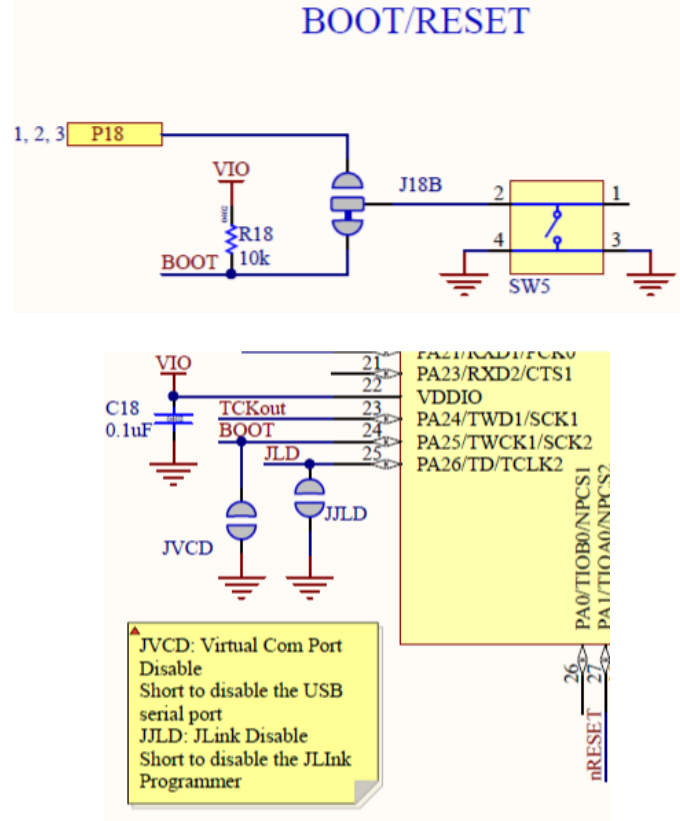

Figure 4: Schematic – Reset

2.3 Buttons

The evaluation board has four user buttons: Button 1, Button 2, Button 3, and Button 4. All buttons are active low; they will connect to ground when pressed. The button GPIO pins must be configured with internal pull-up resistors for proper operation when using the user buttons. The buttons and ESD protection can be completely removed from the circuit by breaking the associated jumper.

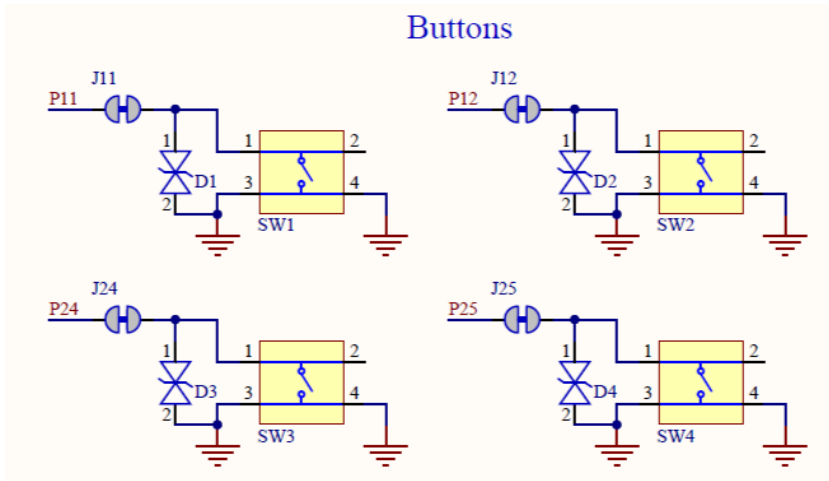

Figure 5: Schematic – User buttons

2.4 LEDs

User LEDs are provided on the evaluation board - two red and two green. An RGB LED is included as well and can be enabled by changing the position of JLED. LEDs are powered by VIO and are active low. The GPIO should be enabled for high drive when sinking current for the LEDs. The LEDs can be completely removed from the circuit by breaking the associated jumper.

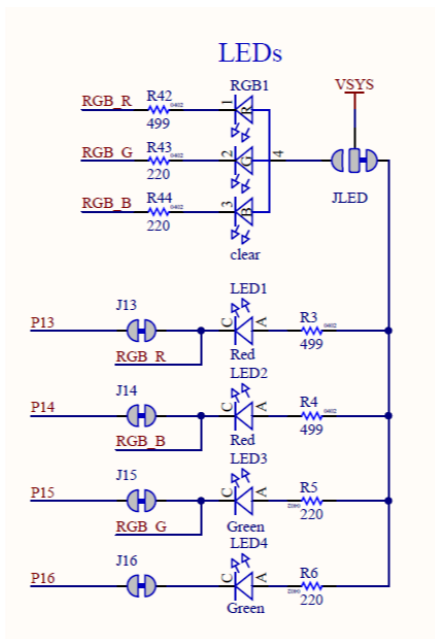

Figure 6: Schematic – User LEDs

2.5 Virtual COM port

The evaluation board allows for easy serial communication with the BMD-34 series modules and a connected computer. The Interface IC provides a virtual COM port USB device that connects to four GPIO pins on the module, allowing for UART communication with or without hardware flow control. The UART lines can be completely removed from the circuit by breaking the associated jumpers.

BMD-34 Pin Name	BMD-34 Function	Jumper	Interface IC Function
P0.05	RTS	J05	CTS
P0.06	TXD	J06	RXD
P0.07	CTS	J07	RTS
P0.08	RXD	J08	TXD

Table 2: Virtual COM port

2.6 32 kHz crystal oscillator

The evaluation board has a 32.768 kHz crystal oscillator connected to the BMD-34 module by default. This allows the module to use any of the three available low frequency (LF) clock sources: an internal calibrated RC oscillator, an internal synthesized clock (derived from the 32 MHz clock), or an external crystal oscillator. The external crystal oscillator is the most accurate and lowest power LF clock option. For applications without strict time keeping requirements, the internal calibrated RC oscillator is often suitable. The crystal is connected to the module through a solder select jumper, allowing either the crystal or the IO header to be connected to the module's GPIO pins.

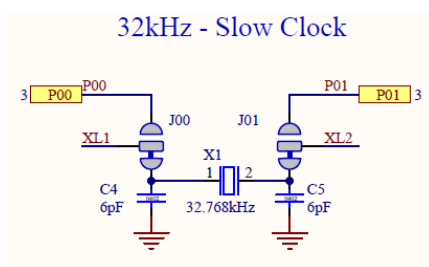

Figure 7: Schematic – 32 kHz crystal

2.7 NFC connector

Connection to an external NFC antenna is provided through a Molex flat-flex connector, Part number 051281-0594. Capacitors “C2” and “C3” provide tuning of the NFC antenna for resonance at 15.56 MHz.

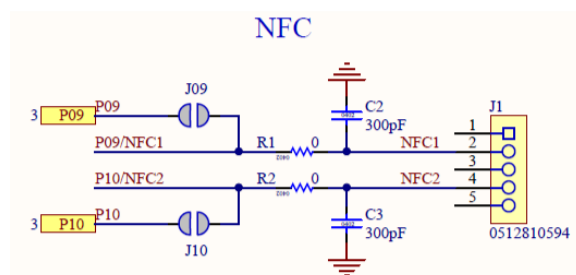

Figure 8: NFC connector

2.8 Current sensing headers

The evaluation board provides two current sensing headers. “JBMD” allows for power consumption measurement of the BMD-34 module and “JSHD” allows for power consumption measurement of the shields connected to the Arduino-style headers (“VSHLD” power only).

Each 3-pin 2.54 mm pitch header has two pins connected across a 1 Ω current-sense resistor powering the module or the shield, and the third pin to ground. To measure current consumption, use a multimeter or other precision voltage measurement device to measure voltage drop across pins one and two. Current can also be measured directly by removing “RBMD” / “RSHD” and using a current meter in series with the two voltage pins. The default hardware configuration does not require any modification of the current sense headers for the BMD-34-EVAL to perform properly.

- ☞ Only current flowing through “VBMD” into the module is measured; current sunk through GPIO pins is not measured.

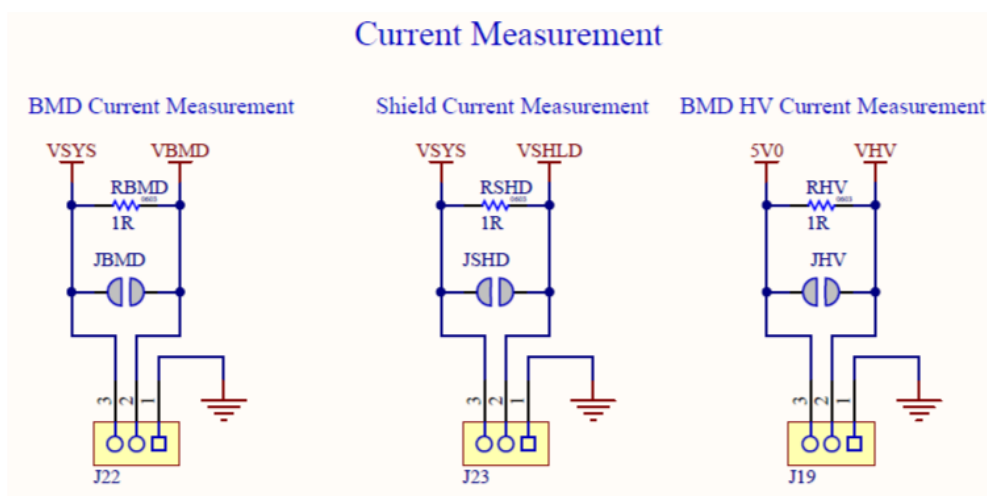

Figure 9: Current sensing header layout

2.9 External SEGGER J-Link™ debug interface

External target hardware can be connected to J3 for firmware programming and debug. The SEGGER debug interface is implemented as shown in Figure 10. J3 is implemented with a 2x5 10-pin header on 1.27 mm centers.

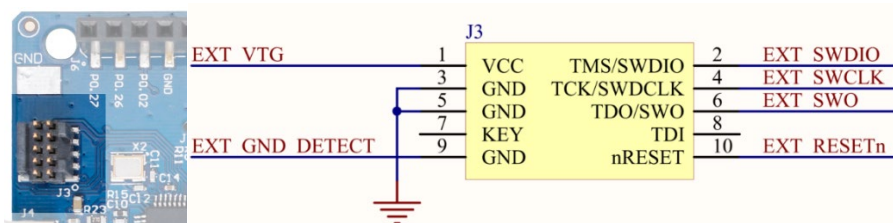

Figure 10: External J-Link debug interface

In order to enable the external J-Link connection, ensure the following are implemented on the target hardware:

- EXT_VTG is used by the debug interface as an input to sense power applied to the external circuit. Only voltages of 3.0 V to 3.3 V are supported. Target hardware operating voltages outside of this range require the use of an external SEGGER J-Link Debug Probe. Connect EXT_VTG to the BMD-34 series power supply (VCC) on the target hardware.

- EXT_GND_DETECT is used by the debug interface to detect the presence of an external target hardware. Connect EXT_GND_DETECT to GND on the target hardware.
- Connect GND to GND on the target hardware.
- Connect EXT_SWDIO to SWDIO and EXT_SWCLK to SWDCLK on the target BMD-34 module.
- (Optional) Connect EXT_SWO and/or EXT_RESETn on the target BMD-34 module.
- Connect external power to the target hardware, then connect the BMD-34 series evaluation board to USB.

🔧 At this point, the debug interface will interact with the target hardware instead of the on-board BMD-34 module.

2.10 QSPI

A 64 Mbit Quad SPI (MX25R6435F) flash is available on the BMD-34-EVAL. This memory can be used for execute in place (XIP) directly from the flash as well as general data storage.

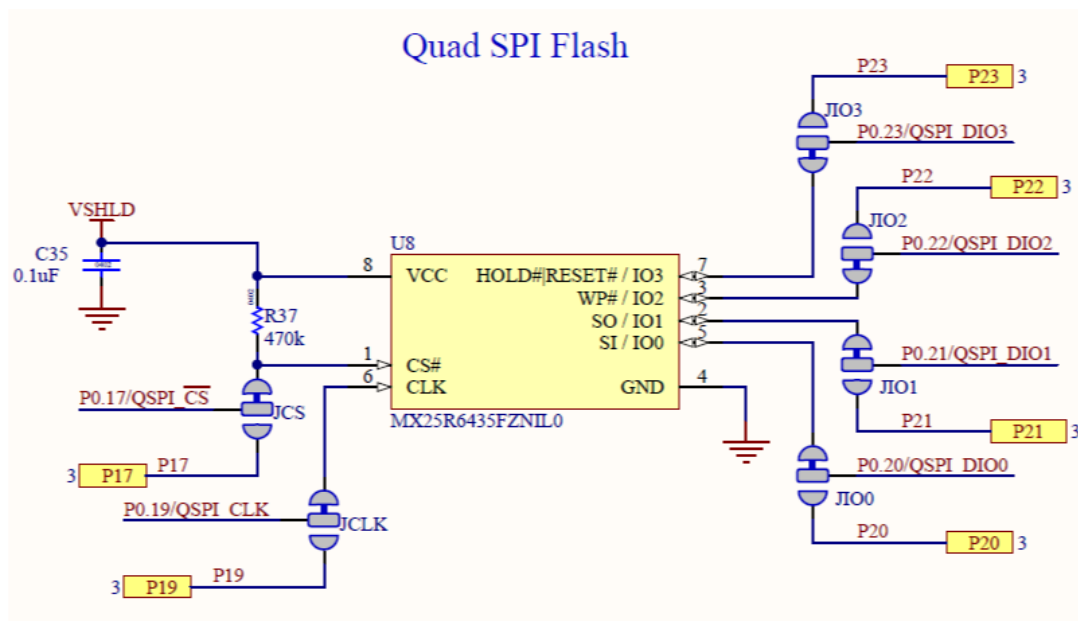

Figure 11: Quad SPI flash

2.11 GPIO jumpers

Many solder bridge jumpers on the board are available to allow GPIO configuration. Most solder jumpers are used to remove on-board components from the module's GPIO nets to eliminate interference with external circuitry added on the I/O headers. All GPIOs are directly connected to the I/O Headers by default, except P0.00 & P0.01 (32 kHz crystal), P0.09 & P0.10 (NFC antenna), and P0.17 & P0.20 - P0.23 (QSPI). These are disconnected from the I/O headers as they would interfere with the default functions. The GPIO jumpers are shown on the bottom of the BMD-34 evaluation kit.

BMD-340			
GPIO	Function	Jumper	HW
P0.00	XL1	J00	BMD PIN
P0.01	XL2	J01	BMD PIN
P0.06	TXD	JDAT	IF MCU
P0.08	RXD		EN
P0.05	RTS	JFC	BMD PIN
P0.07	CTS		BMD PIN
P0.09	NFC1	J09 R1	PIN NFC
P0.10	NFC2	J10 R2	BMD PIN NFC

BMD-340			
GPIO	Function	Jumper	HW
P0.11	Button 1	J11	BMD PIN
P0.12	Button 2	J12	BMD PIN
P0.24	Button 3	J24	BMD PIN
P0.25	Button 4	J25	BMD PIN
P0.13	LED 1	J13	VSYS
P0.14	LED 2	J14	BMD PIN
P0.15	LED 3	J15	BMD PIN
P0.16	LED 4	J16	BMD PIN

GPIO	FNC	JMP	HW
P0.17	CS	JCS	BMD PIN QSPI FLASH
P0.19	CLK	JCLK	
P0.20	DIO0	JIO0	
P0.21	DIO1	JIO1	
P0.22	DIO2	JIO2	
P0.23	DIO3	JIO3	

Figure 12: GPIO jumpers

2.12 Header pin-out

Headers J5 - J9 and J11 break out the IO signals from the BMD-34 module on 2.54 mm pitch headers.

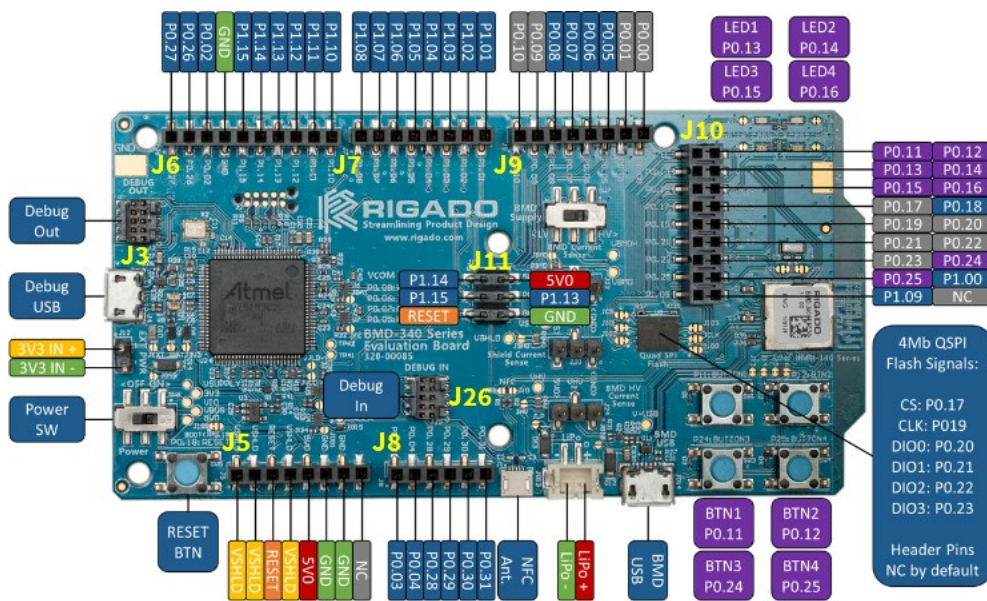

Figure 13: BMD-340 evaluation board pin-out

⚠ The I/O pins of the BMD-34 EVK are not 5 V tolerant. Arduino Uno® style shields shall be configured to use +3.3 V DC (VSHLD) as the I/O voltage reference.

The tables below are presented in order of the headers on the BMD-34-eval boards.

Pin	Pin name	nRF52840	Function
1	VSHLD	-	+3.3 V Shield Power
2	VSHLD	-	+3.3 V Shield Power
3	RESET	P0.18	RESET_N / GPIO
4	VSHLD	-	+3.3 V Shield Power
5	5V0	-	+5.0 V USB Power
6	GND	-	Ground
7	GND	-	Ground
8	-	-	No connection

Table 3: Header J5

Pin	Pin name	nRF52840	Function
1	P0.27	P0.27	GPIO
2	P0.26	P0.26	GPIO
3	P0.02	P0.02	GPIO / AIN0
4	GND	-	Ground
5	P1.15	P1.15	GPIO
6	P1.14	P1.14	GPIO
7	P1.13	P1.13	GPIO
8	P1.12	P1.12	GPIO
9	P1.11	P1.11	GPIO
10	P1.10	P1.10	GPIO

Table 4: Header J6

Pin	Pin name	nRF52840	Function
1	P1.08	P1.08	GPIO
2	P1.07	P1.07	GPIO
3	P1.06	P1.06	GPIO
4	P1.05	P1.05	GPIO
5	P1.04	P1.04	GPIO
6	P1.03	P1.03	GPIO
7	P1.02	P1.02	GPIO
8	P1.01	P1.01	GPIO

Table 5: Header J7

Pin	Pin name	nRF52840	Function
1	P0.03	P0.03	GPIO / AIN1
2	P0.04	P0.04	GPIO / AIN2
3	P0.28	P0.28	GPIO / AIN4
4	P0.29	P0.29	GPIO / AIN5
5	P0.30	P0.30	GPIO / AIN6
6	P0.31	P0.31	GPIO / AIN7

Table 6: Header J8

Pin	Pin name	nRF52840	Function
1	P0.10	P0.10	OPEN / GPIO
2	P0.09	P0.09	OPEN / GPIO
3	P0.08	P0.08	GPIO
4	P0.07	P0.07	GPIO / TRACECLK
5	P0.06	P0.06	GPIO
6	P0.05	P0.05	GPIO / AIN3
7	P0.01	P0.01	OPEN / GPIO
8	P0.00	P0.00	OPEN / GPIO

Table 7: Header J9

Pin	Pin name	nRF52840	Function
1	P0.11	P0.11	GPIO / TRACED[2]
2	P0.12	P0.12	GPIO / TRACED[1]
3	P0.13	P0.13	GPIO
4	P0.14	P0.14	GPIO
5	P0.15	P0.15	GPIO
6	P0.16	P0.16	GPIO
7	P0.17	P0.17	OPEN / GPIO / QSPI CS
8	P0.18	P0.18	RESET_N / GPIO
9	P0.19	P0.19	OPEN / GPIO / QSPI CLK
10	P0.20	P0.20	OPEN / GPIO / QSPI DIO0
11	P0.21	P0.21	OPEN / GPIO / QSPI DIO1
12	P0.22	P0.22	OPEN / GPIO / QSPI DIO2
13	P0.23	P0.23	OPEN / GPIO / QSPI DIO3
14	P0.24	P0.24	GPIO
15	P0.25	P0.25	GPIO
16	P1.00	P1.00	GPIO / TRACED[0] / SWO
17	P1.09	P1.09	OPEN / GPIO / TRACED[3]
18	-	-	No connection

Table 8: Header J10

Pin	Pin name	nRF52840	Function
1	P1.14	P1.14	GPIO
2	5V0	-	+5.0 V USB Power
3	P1.15	P1.15	GPIO
4	P1.13	P1.13	GPIO
5	RESET	P0.18	RESET_N / GPIO
6	GND		Ground

Table 9: Header J11

3 Setting up the evaluation board

This section provides information on how to set up and program the BMD-340 evaluation kit with an example application.

3.1 Set up the tool chain

1. Install [SEGGER Embedded Studio](#) and [request a license](#).
2. Download the latest [nRF5 SDK](#). Unzip it to a convenient working directory.

Do not alter the directory trees. The examples are configured for relative path positions.

Do not use spaces in the directory path.

3. Install [nRF Connect for desktop](#) and optionally one of the [mobile versions](#). nRF Connect can be used directly with the Device Under Test (DUT) evaluation board for programming and other features.

If using nRF Connect on a desktop, a second evaluation board or a [nRF52 USB Dongle](#) is required to make Bluetooth low energy connections with your DUT.

4. Install the [SEGGER J-Link Commander](#). If presented with a screen to select different IDEs, ensure at least the “SEGGER Embedded Studio ARM” line is selected:

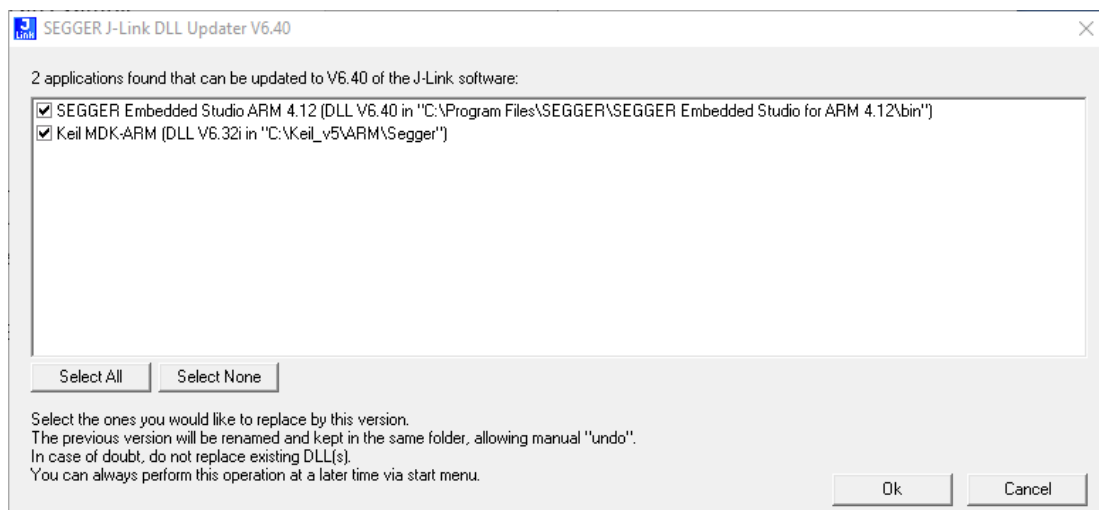

Figure 14: SEGGER J-Link commander install

5. You may need to add the install location to the system PATH. The default location for the J-Link commander is “C:\Program Files (x86)\SEGGER\JLink_Vnnn” where “nnn” is the version number.
6. Install [nRF Toolbox](#) for your mobile device. This will be used with the example below.

3.2 Connect BMD-34 evaluation kit to a computer

The evaluation board is provided with an on-board SEGGER J-Link programmer/debugger.

1. If using the BMD-341-EVAL, connect one of the 2.4GHz antennas from the kit to the module.

Note that the U.FL connector is intended for limited connect / disconnect cycles.

2. Connect the board to a computer using the USB cable provided.

- 👉 The status LED, D5, will flash and then turn solid once the USB device is enumerated. Some flickering is normal.
- 3. After a few seconds, the computer will recognize the evaluation board as a J-Link device and install the USB-Virtual COM Port device driver.
- 4. Run the J-Link Commander:
 - 4.1. JLink on Windows
 - 4.2. JLinkExe on macOS and Linux
- 👉 If prompted to update the J-Link firmware, accept and perform the update.
- 5. Type “connect” at the J-Link> prompt
- 6. Enter the device type at the Device> prompt
 - 6.1. Type nRF52840_XXAA for the BMD-340 or BMD-341
- 7. Enter s to select the SWD interface and accept the default for the speed.
- 8. J-Link will respond with several items. Here is a sample output:

```

C:\Program Files (x86)\SEGGER\JLink_V640>jlink
SEGGER J-Link Commander V6.40 (Compiled Oct 26 2018 15:06:29)
DLL version V6.40, compiled Oct 26 2018 15:06:02

Connecting to J-Link via USB...O.K.
Firmware: J-Link OB-SAM3U128-V2-NordicSemi compiled Jul 12 2018 11:44:41
Hardware version: V1.00
S/N: 683477864
VTref=3.300V

Type "connect" to establish a target connection, '?' for help
J-Link>connect
Please specify device / core. <Default>: NRF52840_XXAA
Type '?' for selection dialog
Device>NRF52840_XXAA
Please specify target interface:
  J) JTAG (Default)
  S) SWD
  T) cJTAG
TIF>s
Specify target interface speed [kHz]. <Default>: 4000 kHz
Speed>
Device "NRF52840_XXAA" selected.

Connecting to target via SWD
Found SW-DP with ID 0x2BA01477
Found SW-DP with ID 0x2BA01477
Scanning AP map to find all available APs
AP[2]: Stopped AP scan as end of AP map has been reached
AP[0]: AHB-AP (IDR: 0x24770011)
AP[1]: JTAG-AP (IDR: 0x02880000)
Iterating through AP map to find AHB-AP to use
AP[0]: Core found
AP[0]: AHB-AP ROM base: 0xE00FF000
CPUID register: 0x410FC241. Implementer code: 0x41 (ARM)
Found Cortex-M4 r0p1, Little endian.
FPUnit: 6 code (BP) slots and 2 literal slots
CoreSight components:
ROMTbl[0] @ E00FF000
ROMTbl[0][0]: E000E000, CID: B105E00D, PID: 000BB00C SCS-M7
ROMTbl[0][1]: E0001000, CID: B105E00D, PID: 003BB002 DWT
ROMTbl[0][2]: E0002000, CID: B105E00D, PID: 002BB003 FPB
ROMTbl[0][3]: E0000000, CID: B105E00D, PID: 003BB001 ITM
ROMTbl[0][4]: E0040000, CID: B105900D, PID: 000BB9A1 TPIU
ROMTbl[0][5]: E0041000, CID: B105900D, PID: 000BB925 ETM
Cortex-M4 identified.
J-Link>
    
```

Figure 15: J-Link commander output

- 9. This confirms that the evaluation board is properly recognized.

10. While still in the J-Link Commander session, save the pre-programmed public Bluetooth address by typing in: `savebin mac_addr.bin 0x10001080 8`
11. Save the file `mac_addr.bin` to a convenient location for future use.
12. Exit the J-Link session by typing `exit`.

At this point, a file titled `mac_addr.bin` will be saved in the current directory. The contents will contain the MAC address in little-endian format:

```
33 22 11 93 54 94 FF FF
```

to correspond to the address `94:54:93:11:22:33`. The last two `FF` values are only fillers to complete the 8-byte read. Public Bluetooth addresses begin with the IEEE-assigned company ID, `94:54:93` or `6C:1D:EB`. The remaining bytes are printed on the 2D and human-readable label on the module. See the module data sheet for additional information.

- This file may be used to restore the Bluetooth address after performing an erase or recover with the J-Link command: `loadbin mac_address.bin 0x10001080`

3.3 Open an example project

- When selecting examples from the SDK, note the following cross reference:

u-blox evaluation board	Nordic SoC	Preferred Nordic SoftDevice	Compatible Nordic DK
BMD-340-EVAL	nRF52840	S140	PCA10056 / nRF52840 DK
BMD-341-EVAL	nRF52840	S140	PCA10056 / nRF52840 DK

Table 10: u-blox evaluation with Nordic DK cross reference

For this guide, the nRF SDK v15.3.0 Heart Rate Service example for the BMD-340-EVAL will be used.

- The latest SDK version should be used whenever possible. The “nRF5_SDK_xx.x.x_yyyyyyy” directory may change. The folders under usually remain the same from version to version.

1. Navigate to the location of the heart rate example from the SDK, typically `<unzipped_location>\nRF5_SDK_15.3.0_59ac345\examples\ble_peripheral\ble_app_hrs`
2. Select the DK Board, SoftDevice and IDE directories. Here is the full path: `<unzipped_location>\nRF5_SDK_15.3.0_59ac345\examples\ble_peripheral\ble_app_hrs\pca10056\s140\ses`
3. Open the project file (`ble_app_hrs_pca10056_s140.emProject`) to start the SEGGER Embedded Studio IDE
4. Build the project (`<F7>`)
5. Once the build is successful, you can download the application code onto the module Board (`Target | Download ble_app_hrs_pca10056_s140`)

- The first time the board is programmed, both the SoftDevice and the application will be downloaded to the module. Once the SoftDevice is loaded, subsequent downloads will only transfer the application. If you need to change SoftDevice versions, erase the board through the IDE: (`Target | Erase All`)

6. On a mobile device, open the nRF Toolbox application. Select the Heart Rate Monitor.
7. Tap Connect. You should see the evaluation board advertising as “Nordic_HRM”.
8. Select this device to see the simulated heart rate being transmitted from the BMD-34 module.

Additional training videos for SEGGER Embedded Studio can be viewed [here](#).

Related documents

- [1] BMD-340 data sheet, doc. no. [UBX-19033353](#)
- [2] BMD-341 data sheet, doc. no. [UBX-19033643](#)
- [3] [Nordic nRF52840 product specification](#)
- [4] [S140 SoftDevice specification](#)
- [5] u-blox package information guide, doc. no. [UBX-14001652](#)

 For regular updates to u-blox documentation and to receive product change notifications, register on our homepage (www.u-blox.com).

Revision history

Revision	Date	Name	Comments
1.0	01-Feb-2018		Initial release.
2.0	05-Jun-2019		Added new modules and changed title to BMD-34-EVAL User Guide Update Nordic SDK version.
R03	24-Oct-2019	brec, smos	Document converted from Rigado BMD-34x evaluation user guide to u-blox BMD-34 evaluation kit user guide.

Contact

For complete contact information, visit us at www.u-blox.com.

u-blox Offices

North, Central and South America

u-blox America, Inc.

Phone: +1 703 483 3180
E-mail: info_us@u-blox.com

Regional Office West Coast:

Phone: +1 408 573 3640
E-mail: info_us@u-blox.com

Technical Support:

Phone: +1 703 483 3185
E-mail: support@u-blox.com

Headquarters

Europe, Middle East, Africa

u-blox AG

Phone: +41 44 722 74 44
E-mail: info@u-blox.com
Support: support@u-blox.com

Asia, Australia, Pacific

u-blox Singapore Pte. Ltd.

Phone: +65 6734 3811
E-mail: info_ap@u-blox.com
Support: support_ap@u-blox.com

Regional Office Australia:

Phone: +61 2 8448 2016
E-mail: info_anz@u-blox.com
Support: support_ap@u-blox.com

Regional Office China (Beijing):

Phone: +86 10 68 133 545
E-mail: info_cn@u-blox.com
Support: support_cn@u-blox.com

Regional Office China (Chongqing):

Phone: +86 23 6815 1588
E-mail: info_cn@u-blox.com
Support: support_cn@u-blox.com

Regional Office China (Shanghai):

Phone: +86 21 6090 4832
E-mail: info_cn@u-blox.com
Support: support_cn@u-blox.com

Regional Office China (Shenzhen):

Phone: +86 755 8627 1083
E-mail: info_cn@u-blox.com
Support: support_cn@u-blox.com

Regional Office India:

Phone: +91 80 405 092 00
E-mail: info_in@u-blox.com
Support: support_in@u-blox.com

Regional Office Japan (Osaka):

Phone: +81 6 6941 3660
E-mail: info_jp@u-blox.com
Support: support_jp@u-blox.com

Regional Office Japan (Tokyo):

Phone: +81 3 5775 3850
E-mail: info_jp@u-blox.com
Support: support_jp@u-blox.com

Regional Office Korea:

Phone: +82 2 542 0861
E-mail: info_kr@u-blox.com
Support: support_kr@u-blox.com

Regional Office Taiwan:

Phone: +886 2 2657 1090
E-mail: info_tw@u-blox.com
Support: support_tw@u-blox.com