

Gateway for the BL20 I/O System

Interface for PROFIBUS-DP

BL20-GW-DPV1

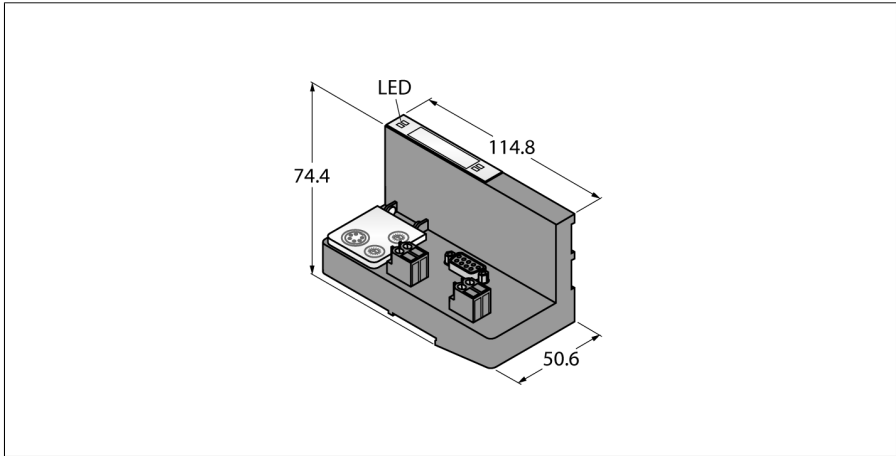

- Rotary coding switch for adjustment of the node address
- Protection class IP20
- 2 x end brackets BL20-WEW35/2-SW
- 1 x end plate BL20-ABPL
- Integrated power supply
- LEDs for display of supply voltage, group and bus errors
- Gateway between the BL20 system and PROFIBUS-DPV0/DPV1
- 12 Mbps
- 9-pin sub-D female connector

Type	BL20-GW-DPV1
ID	6827234
Supply voltage	24 VDC
System power supply	24 VDC / 5 VDC
Field supply	24 VDC
Admissible range	18...30 VDC
Nominal current from module bus	≤ 430 mA
Max. field supply current	10 A
Max. system supply current	1.2 A
Voltage supply connection	Screw terminals
Fieldbus transmission rate	9.6 kbps ... 12 Mbps
Fieldbus addressing	2 rotary switches
Fieldbus address range	1...99
Fieldbus connection technology	1 x female sub-D connector
Fieldbus termination	External
Max. number of I/O modules	64
Service interface	PS/2 socket
Number of diagnostics bytes	3
Number of parameter bytes	5
Dimensions (W x L x H)	50.6 x 114.8 x 74.4 mm
Approvals	CE, cULus, zone 2, Class I, Div. 2
Ambient temperature	0...+55 °C
Storage temperature	-25...+85 °C
Relative humidity	15...95 %, no condensation allowed
Vibration test	Acc. to EN 61131
Shock test	Acc. to IEC 60068-2-27
Drop and topple	acc. to IEC 68-2-31 and free fall to IEC 68-2-32
Electromagnetic compatibility	Acc. to EN 50082-2
Protection class	IP20
MTTF	284 years acc. to SN 29500 (Ed. 99) 20 °C
Included in delivery	2 x end brackets BL20-WEW-35/2-SW, 1 x end plate BL20-ABPL

Field/System Supply

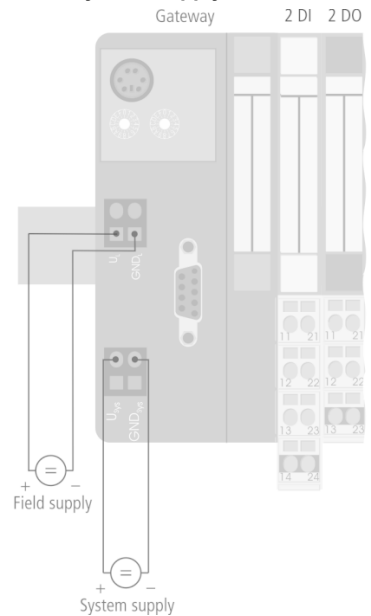

Functional principle

BL20 gateways are the head component of a BL20 station. They are designed to interface the modular fieldbus nodes to the higher level fieldbus (PROFIBUS-DP, DeviceNet, CANopen, Ethernet).

All BL20 electronic modules communicate over the internal module bus, the data of which is transferred to the fieldbus via the gateway, so that all I/O modules can be configured independently of the bus system.

**Gateway for the BL20 I/O System
Interface for PROFIBUS-DP
BL20-GW-DPV1**

Anschlussübersicht

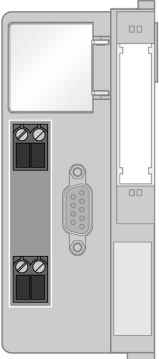
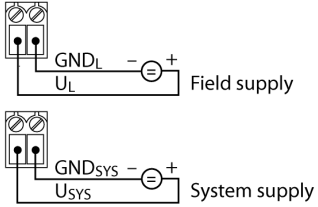
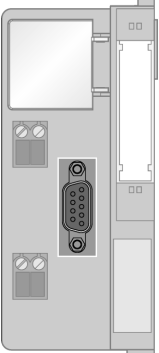
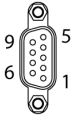
	<p>Power Supply The U_{sys} system supply feeds power to the gateway and the I/O modules. The U_{L} field supply feeds power to the sensors and actuators.</p>	<p>Pin Assignment</p> 
	<p>PROFIBUS-DP Fieldbus cable (example): D9T451-2M (ident no. 6915759) or RSSW-D9T451-2M (ident no. 6915779)</p>	<p>Pin Assignment</p>  <ul style="list-style-type: none"> 1 = shield 2 = n.c. 3 = RD (Bus B) 4 = n.c. 5 = GND 6 = 5 VDC 7 = n.c. 8 = GN (Bus A) 9 = n.c.