



2200W Bidirectional Power Supply with Single Output

BIC-2200 series

Dimension			
L	W	H	
330	140	41 (1U)	mm
13	5.5	1.61(1U)	inch



■ Features

- Built-in active PFC function
- High efficiency up to 93%
- Forced air cooling by built-in DC fan
- Active current sharing up to 5 units
- Protections: Short circuit / Overload / Over voltage / Over temperature / Anti-Islanding / Under / Over frequency
- 5 years warranty

■ Applications

- Marine battery charger module
- Electric scooter or vehicle charger station
- Wastewater treatment system
- Electrolysis system
- Kinetic energy recovery system

■ Description

BIC-2200 series is a 2.2KW bidirectional power supply which is designed to control the power transferred from AC grid to DC side and DC side to AC grid for energy recycle. The implementation of a bidirectional power supply can allow for battery recharge from the grid, and battery energy recycle to the AC grid. With built-in functions such as active current sharing, remote ON/OFF control, and digital communication, BIC-2200 provides vast design flexibility for battery test equipment, charging station, laser system, and kinetic energy recovery system.

■ Model Encoding / Order Information

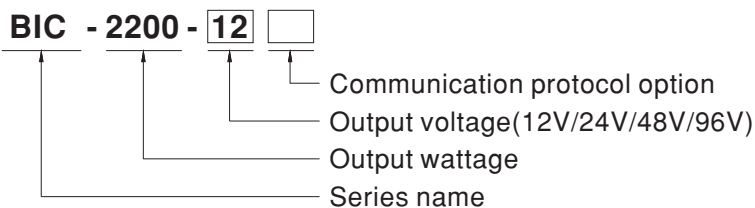

Type	Communication Protocol	Note
Blank	None protocol	In Stock
CAN	CANBus protocol	By request

SPECIFICATION

MODEL		BIC-2200-12	BIC-2200-24	BIC-2200-48	BIC-2200-96		
AC to DC Direction	OUTPUT	DC VOLTAGE	12V	24V	48V	96V	
		RATED CURRENT	180A	90A	45A	22.5A	
		RATED POWER	2160W				
		FULL POWER VOLTAGE RANGE	12 ~ 15V	24 ~ 28V	48 ~ 65V	96 ~ 112V	
		RIPPLE & NOISE (max.) Note.2	280mVp-p	350mVp-p	400mVp-p	600mVp-p	
		VOLTAGE ADJ. RANGE	10 ~ 15V	19 ~ 28V	38 ~ 65V	76 ~ 112V	
		CURRENT ADJ. RANGE	0 ~ 180A	0 ~ 90A	0 ~ 45A	0 ~ 22.5A	
		VOLTAGE TOLERANCE Note.3	±1.0%	±1.0%	±1.0%	±1.0%	
		LINE REGULATION	±0.5%	±0.5%	±0.5%	±0.5%	
		LOAD REGULATION	±0.5%	±0.5%	±0.5%	±0.5%	
		SETUP, RISE TIME	1800ms, 60ms/230VAC at full load				
		INPUT	AC VOLTAGE RANGE	180 ~ 264VAC			
			FREQUENCY RANGE	47 ~ 63Hz			
			POWER FACTOR (Typ.)	0.98/230VAC at full load			
EFFICIENCY (Typ.) Note.5	90%		93%	93%	93%		
AC CURRENT (Typ.)	11A/230VAC						
INRUSH CURRENT (Typ.)	COLD START 35A/230VAC						
LEAKAGE CURRENT	<2mA/230VAC						
TOTAL HARMONIC DISTORTION	<3%(@load>100%/230VAC) Please refer to "TOTAL HARMONIC DISTORTION(THD)"section						
DC to AC Direction	INPUT	MAX. INPUT POWER	1800W				
		FULL POWER VOLTAGE RANGE	12 ~ 15V	24 ~ 28V	48 ~ 65V	96 ~ 112V	
		DC VOLTAGE RANGE	10 ~15V	19 ~ 28V	38 ~ 65V	76 ~ 112V	
		MAX. INPUT CURRENT	150A	75A	37.5A	18.5A	
	OUTPUT	RATED OUTPUT POWER (Typ.) (@230V, 50Hz)	1550VA				
		VOLTAGE RANGE	180 ~ 264VAC				
		FREQUENCY RANGE	47 ~ 63Hz				
		AC CURRENT (Typ.)	8A/230VAC				
		POWER FACTOR (Typ.)	0.98/230VAC at full load				
		EFFICIENCY (Typ.) Note.5	90.5%	93%	93%	93%	
TOTAL HARMONIC DISTORTION	<5% (@load>100%/230VAC)						
PROTECTION	OVER LOAD	105 ~ 115% rated output power AC to DC Constant current limiting, shut down DC O/P voltage 5 sec. after DC O/P voltage is down low, re-power on to recover DC to AC Shut down AC O/P voltage, re-power on to recover					
	SHORT CIRCUIT	Shut down O/P current, re-power on to recover					
	OVER VOLTAGE	17.6 ~ 20.8V	33.6 ~ 39.2V	72.6 ~ 86V	134 ~ 157V		
	OVER TEMPERATURE	Shut down O/P voltage, recovers automatically after temperature goes down					
	ISLANDING PROTECTION Note.7	Yes					
FUNCTION	REMOTE ON-OFF CONTROL	By electrical signal or dry contact Short: Power ON Open: Power OFF Please refer to the Function Manual infollowing					
	BIDIRECTION SWITCH TIME(DEFAULT)	1ms					
	ALARM SIGNAL	Isolated TTL signal output for T-Alarm, DC-OK and Fault. Please refer to the Function Manual in following pages					
	AUXILIARY POWER	12V@0.5A tolerance ±5%, ripple 150mVp-p					
	BATTERY MODE RATED CURRENT(default) Note.8	AC to DC	160A	80A	40A	20A	
ENVIRONMENT	WORKING TEMP.	-30 ~ +70°C (Refer to "Derating Curve")					
	WORKING HUMIDITY	20 ~ 90% RH non-condensing					
	STORAGE TEMP., HUMIDITY	-40 ~ +85°C, 10 ~ 95% RH non-condensing					
	TEMP. COEFFICIENT	±0.03%/°C (0 ~ 50°C)					
	VIBRATION	10 ~ 500Hz, 2G 10min./1cycle, 60min. each along X, Y, Z axes					
	SAFETY & EMC (Note 4)	SAFETY STANDARDS	UL62368-1, CAN/CSA C22.2 No.62368-1-14,TUV BS EN/EN62368-1, EAC TP TC 004, IEC62477-1(by request) approved				
WITHSTAND VOLTAGE Note.9		I/P-O/P:3KVAC I/P-FG:2KVAC O/P-FG:500VAC					
ISOLATION RESISTANCE Note.9		I/P-O/P, I/P-FG, O/P-FG:100M Ohms / 500VDC / 25°C / 70% RH					
EMC EMISSION		BS EN/EN55032					
		Parameter	Standard		Test Level / Note		
		Conducted	BS EN/EN55032 (CISPR32)		Class B		
		Radiated	BS EN/EN55032 (CISPR32)		Class A		
		Harmonic Current	BS EN/EN61000-3-2		-----		
Voltage Flicker		BS EN/EN61000-3-3		-----			
EMC IMMUNITY		BS EN/EN55035, BS EN/EN61000-6-2					
		Parameter	Standard		Test Level / Note		
		ESD	BS EN/EN61000-4-2		Level 3, 8KV air ; Level 2, 4KV contact		
		Radiated	BS EN/EN61000-4-3		Level 3		
		EFT / Burst	BS EN/EN61000-4-4		Level 3		
	Surge	BS EN/EN61000-6-2		2KV/Line-Line 4KV/Line-Earth			
	Conducted	BS EN/EN61000-4-6		Level 3			
	Magnetic Field	BS EN/EN61000-4-8		Level 4			
Voltage Dips and Interruptions	BS EN/EN61000-4-11		>95% dip 0.5 periods, 30% dip 25 periods, >95% interruptions 250 periods				
OTHERS	MTBF	155.56K hrs min. Telcordia SR-332 (Bellcore) ; 46K hrs min. MIL-HDBK-217F (25°C)					
	DIMENSION	330*140*41mm (L*W*H)					
	PACKING	2.9Kg; 4pcs/12.6Kg/1.22CUFT					
NOTE	<p>1. All parameters NOT specially mentioned are measured at 230VAC input, rated load and 25°C of ambient temperature.</p> <p>2. Ripple & noise are measured at 20MHz of bandwidth by using a 12" twisted pair-wire terminated with a 0.1uf & 47uf parallel capacitor.</p> <p>3. Tolerance : includes set up tolerance, line regulation and load regulation.</p> <p>4. Need additional EMI filter to meet regulations of EMC conducted and radiated emission. Characteristics of EMI filter please refer to the table, Minimum Insertion Loss.</p> <p>5. The efficiency is measured at 75% load.</p> <p>6. The ambient temperature derating of 5°C/1000m with fan models for operating altitude higher than 2000m(6500ft).</p> <p>7. Anti-islanding protection by Fault signal or Error flag by CANBus protocol. (CANBus model only)</p> <p>8. CANBus model only.</p> <p>9. During withstandards voltage and isolation resistance testing, the screw "A" shall be temporarily removed, and shall be installed back after the testing</p> <p>※ Product Liability Disclaimer : For detailed information, please refer to https://www.meanwell.com/serviceDisclaimer.aspx</p>						

■ BLOCK DIAGRAM

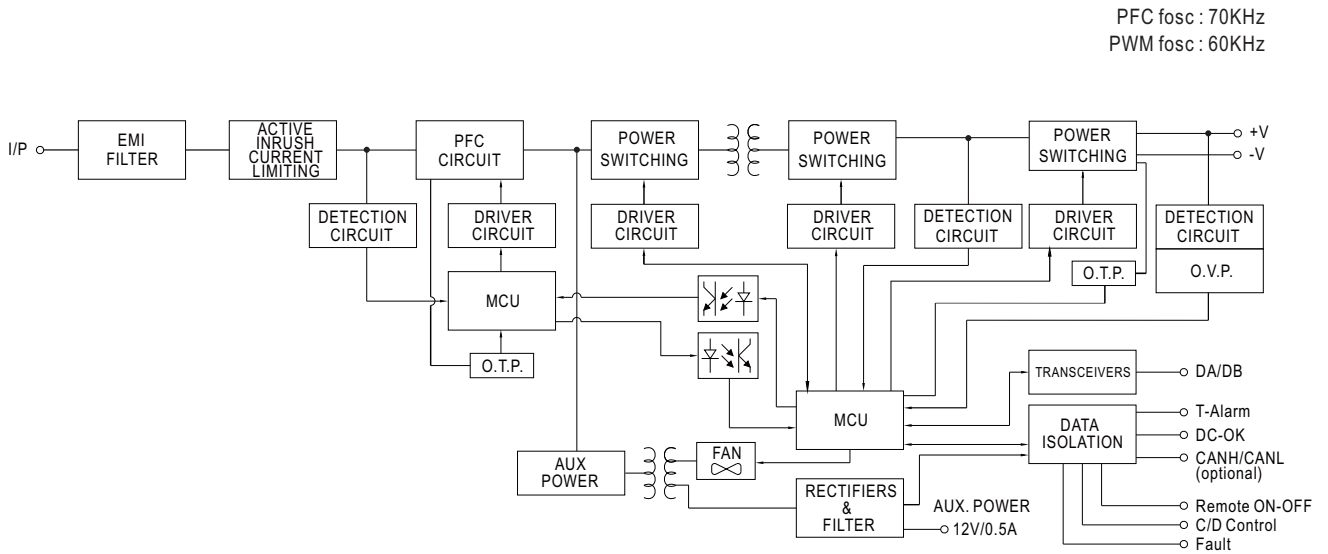

■ DERATING CURVE

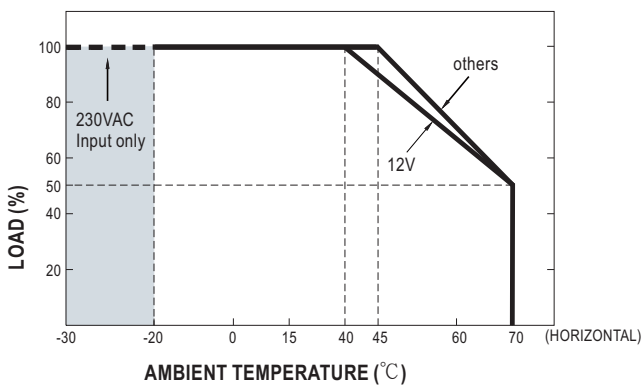

■ STATIC CHARACTERISTICS

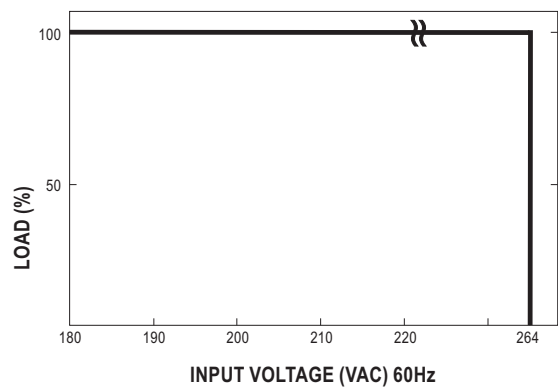

MECHANICAL SPECIFICATION

Case No. 277C

Unit:mm

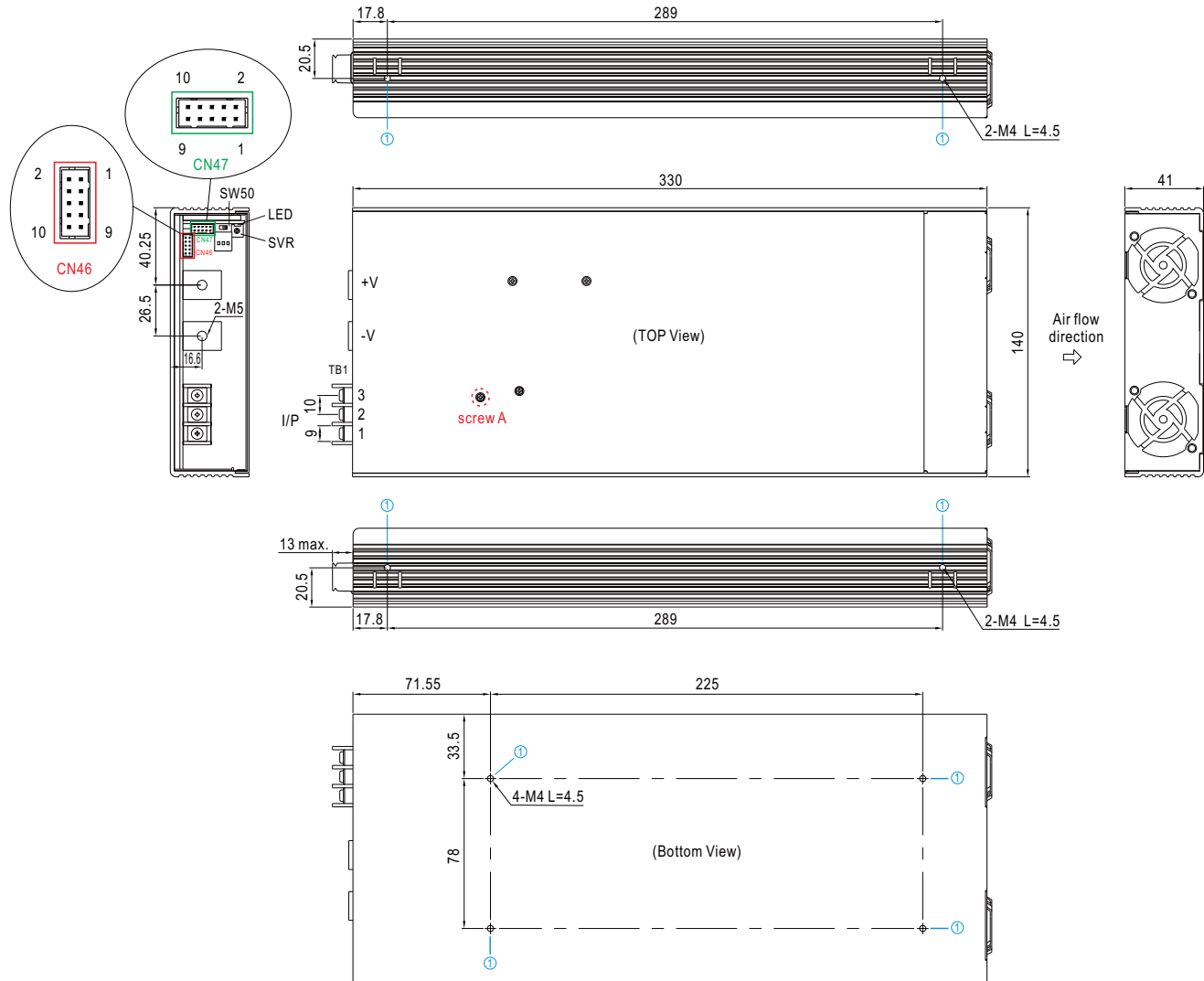

AC Input Terminal(TB1) Pin NO. Assignment

Pin No.	Assignment	Terminal	Max mounting torque
1	AC/L	DECA T35-EO32-03	18Kgf-cm
2	AC/N		
3	FG \perp		

DC Output Terminal Pin No. Assignment

Assignment	Diagram	Maximum mounting torque
+V, -V		10Kgf-cm

LED Status Indicators

LED	Description
	Green AC to DC Direction, functions as regular power supply.
	Green DC to AC Direction, functions as grid inverter.
	Red Abnormal status (Over temperature protection, Overload protection, Fan fail.)

- Light
- Flash

Mounting Instruction

Hole No.	Recommended Screw Size	MAX. Penetration Depth L	Recommended mounting torque
①	M4	4.5mm	7~10Kgf-cm

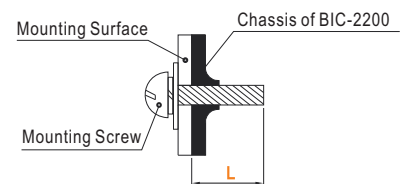

※Control Pin No. Assignment(CN46) : HRS DF11-10DP-2DS or equivalent



Mating Housing	HRS DF11-10DS or equivalent
Terminal	HRS DF11-10SC or equivalent

Pin No.	Function	Description
1	+12V-AUX	Auxiliary voltage output, 11.4~12.6V, referenced to GND-AUX (pin 2,4). The maximum output current is 0.5A. This output is not controlled by the Remote ON/OFF control.
2,4	GND-AUX	Auxiliary voltage output GND. The signal return is isolated from the output terminals (+V & -V).
3	+5V-AUX	Auxiliary voltage output, 4.5~5.5V, referenced to GND-AUX (pin 2,4) only for Remote ON/OFF used. This output is not controlled by the Remote ON/OFF control.
5	Remote ON-OFF	The unit can turn the output ON/OFF by electrical signal or dry contact between Remote ON/OFF and +5V-AUX(pin 3). (Note.1)
6	C/D Control	High (4.5 ~ 5.5V) : Battery Charging mode Low (-0.5 ~ 0.5V) : Battery Discharging mode (Note.1)
7	DC-OK	High (4.5 ~ 5.5V) : When the $V_{out} \leq 80\% \pm 5\%$. Low (-0.5 ~ 0.5V) : When $V_{out} \geq 80\% \pm 5\%$. The maximum sourcing current is 4mA and only for output. (Note.1)
8	Fault	High (4.5 ~ 5.5V) : When the $V_{ac} \leq 80\% \pm 5\%$, OLP, SCP,OTP,OVP,AC Fail,fan lock, islanding protection. Low (-0.5 ~ 0.5V) : When $V_{ac} \geq 80\% \pm 5\%$ and when power supply work normally. The maximum sourcing current is 4mA and only for output. (Note.1)
9	T-ALARM	High (4.5 ~ 5.5V) : When the internal temperature exceeds the limit of temperature alarm, or when any of the fans fails. Low (-0.5 ~ 0.5V) : When the internal temperature is normal, and when fans work normally. The maximum sourcing current is 4mA and only for output(Note.1)
10	NC	-----

Note 1 : Isolated signal, referenced to GND-AUX(S).

※Control Pin No. Assignment(CN47): HRS DF11-10DP-2DS or equivalent



Mating Housing	HRS DF11-10DS or equivalent
Terminal	HRS DF11-10SC or equivalent

Pin No.	Function	Description
1,2	DA	Differential digital signal for parallel control. (Note.1)
3,4	DB	
5,6	GND	Auxiliary voltage output GND. The signal return is isolated from the output terminals (+V & -V).
7	CANH (optional)	For CANBus model: Data line used in CANBus interface. (Note.2)
8	CANL (optional)	For CANBus model: Data line used in CANBus interface. (Note.2)
9,10	GND-AUX	Auxiliary voltage output GND. The signal return is isolated from the output terminals (+V & -V).

Note 1 : Non-isolated signal, referenced to [-V (signal)]

Note 2 : Isolated signal, referenced to GND-AUX(S).

※DIP Switch Position Assignment(DIP-SW50): Please refer to the Function Manual.

Assignment	Diagram
DA, DB Signal and parallel control function (1)Non-parallel operation (a) set the DIP switch of position OFF. (2)Parallel operation (a) set the DIP switch of position ON . (b) PSUs are configured in parallel operation.	

◎ Bidirection process

BIC-2200 possess forward (AC to DC) output and reverse (DC to AC) output conversion function. Users are able to select different modes of BIC-2200 according to requirement. Before entering detailed function explanation, please refer to following definitions. And refer to the table below for operation modes of BIC-2200.

Forward conversion (AC to DC):

The power is provided from AC grid to load through BIC-2200, it transfers AC energy into DC power. In this mode, BIC-2200 acts similar to battery charger.



Reverse conversion (DC to AC):

In reverse mode, it works oppositely to the forward conversion. The power is provided from either the battery or DC source to the AC grid. Output range of AC is from 180Vac~264Vac and 47Hz~63Hz. As long as the AC grid is within the range, BIC-2200 can work under smoothly.



Forward/Reverse auto transform mode (default):

This is default factory setting, BIC-2200 operates as table below

Condition	Mode
Set voltage > load voltage	AC to DC
Set voltage < load voltage	DC to AC

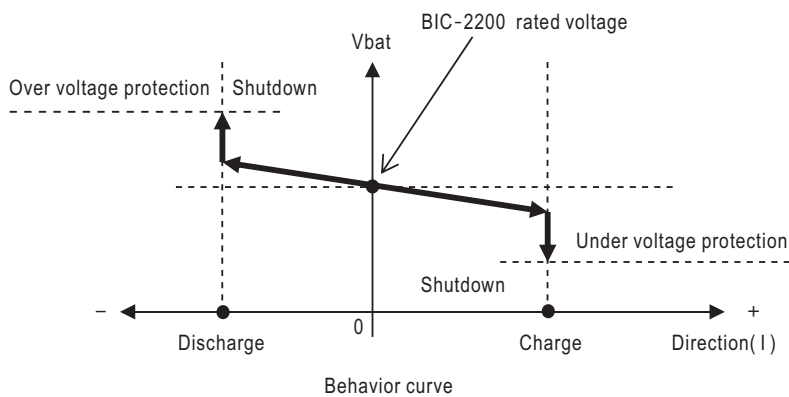

Programmable battery charge/discharge mode:

This mode only can be activated by CAN bus with optional model and operation behavior is as below.

Condition	Mode
C/D = 1	AC to DC
C/D = 0	DC to AC

◎ Current Sharing

BIC-2200 has the built-in active current sharing function and can be connected in parallel, up to 5 units, to provide higher output power as exhibited below :

- ※ The power supplies should be paralleled using short and large diameter wiring and then connected to the load.
- ※ In parallel connection, power supply with the highest output Voltage will be the master unit and its Vout will be the DC bus voltage.
- ※ The total output current must not exceed the value determined by the following equation:

$$\text{Maximum output current at parallel operation} = (\text{Rated current per unit}) \times (\text{Number of unit}) \times 0.95$$
- ※ When the total output current is less than 5% of the total rated current, or say $(5\% \text{ of Rated current per unit}) \times (\text{Number of unit})$ the current shared among units may not be balanced.
- ※ Under parallel operation ripple of the output voltage may be higher than the SPEC at light load condition. It will go back to normal ripple level once the output load is more than 5%.
- ※ CN47/SW50 Function pin connection

Parallel	PSU1		PSU2		PSU3		PSU4		PSU5	
	CN47	SW50	CN47	SW50	CN47	SW50	CN47	SW50	CN47	SW50
1 unit	X	ON	—	—	—	—	—	—	—	—
2 unit	V	ON	V	ON	—	—	—	—	—	—
3 unit	V	ON	V	OFF	V	ON	—	—	—	—
4 unit	V	ON	V	OFF	V	OFF	V	ON	—	—
5 unit	V	ON	V	OFF	V	OFF	V	OFF	V	ON

(V : CN47 connected ; X : CN47 not connected)

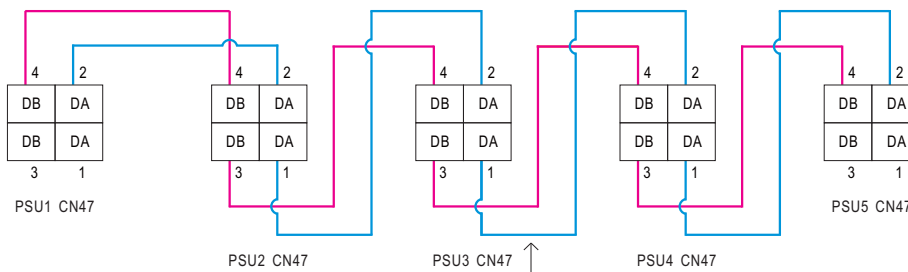
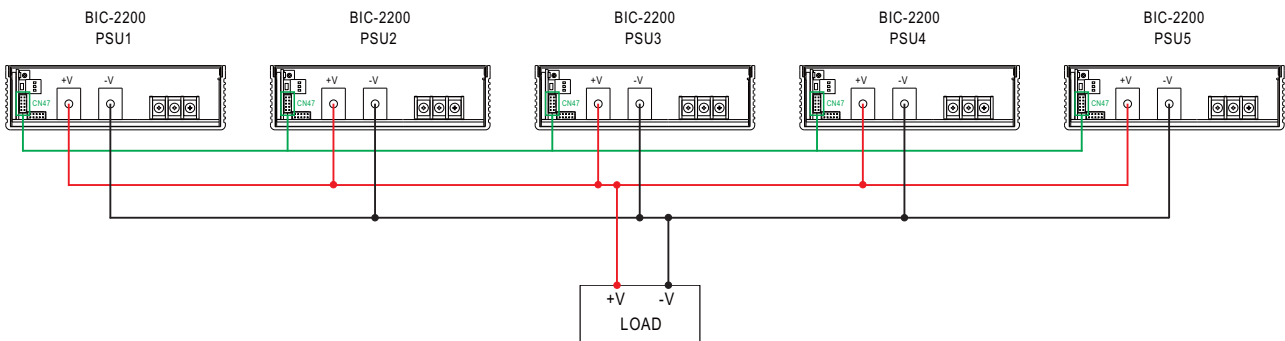

If the lines of CN47 are too long, they should be twisted in pairs to avoid the noise.

◎ DA, DB connected mutually in parallel.

GUIDANCE OF ADDITIONAL FILTER

1.Schematic

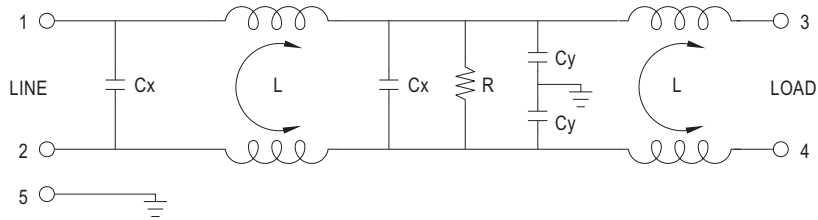

2.Minimum insertion loss (In dB at 50 Ω system)

FREQ. MHz	0.01	0.05	0.10	0.15	0.50	1.0	5.0	10	30
COM. MODE dB	2	5	8	10	30	35	55	45	30
DIF. MODE dB	4	15	18	18	45	50	40	40	40

3.Configuration

