

1) Sensing surface, 2) Housing, 3) Cover, 4) Power indicator green, 5) Function indicator yellow



Basic features

Approval/Conformity	cULus CE UKCA WEEE
Basic standard	IEC 60947-5-2
Scope of delivery	Holder Installation guide
Sensitivity	Switching distance adjustable
Series	R08

Display/Operation

Function indicator	yes
Power indicator	yes
Setting	Teachable

Electrical connection

Cable diameter D	3.40 mm
Cable length L	0.3 m
Conductor cross-section	0.14 mm ²
Connection	M12x1-Male, 4-pin, A-coded
Number of conductors	4
Polarity reversal protected	yes
Protection against device mix-ups	yes
Short-circuit protection	yes

Electrical data

Load capacitance max. at Ue	0.001 µF
No-load current I _o max. at Ue	12.5 mA
Operating voltage U _b	18...30 VDC
Rated insulation voltage U _i	75 V DC
Rated operating current I _e	50 mA
Rated operating voltage U _e DC	24 V
Ready delay t _v max.	200 ms
Residual current I _r max.	10 µA
Ripple max. (% of U _e)	10 %
Switching frequency	50 Hz
Utilization category	DC -13
Voltage drop static max.	1.5 V

Environmental conditions

Ambient temperature	-25...70 °C
IP rating	IP67

Functional safety

MTTF (40 °C)	98 a
--------------	------

IO-Link

IO-Link Profil IDs	0x0001 SSP0
IO-Link function classes	0x8000 Device Identification 0x8001 Binary Data Channel 0x8002 Process Data Variables 0x8003 Device Diagnosis 0x8004 Teach Commands
Supported IO-Link Profiles	Legacy Smart Sensor Profile

Capacitive Sensors
BCS R08RRE-PIM80C-EP00,3-GS04
Order Code: BCS012N



Interface

Cycle time min.	5 ms
Interface	IO-Link 1.1
Process data OUT	2 bytes
Switching output	PNP normally open (NO)

Material

Housing material	PP
Material jacket	PUR
Material sensing surface	PP

Mechanical data

Dimension	34 x 16 x 8 mm
Installation	for flush mounting
Size	Block style
Tightening torque	0.2 Nm

Range/Distance

Hysteresis H max. (% of Sr)	20.0 %
Measuring range	1...8 mm
Real switching distance sr	8 mm
Repeat accuracy max. (% of Sr)	5.0 %
Temperature drift max. (% of Sr)	20 % [-5...55 °C]

Remarks

For full calibration connect input DI to L+ for 2...7 seconds. For empty calibration connect to L+ for 7..12 seconds.
 Input DI can be used for teaching the switching point. In normal operation input DI should be connected continuously to L-.
 Switching output- and function programmable using IO-Link.
 For more information about MTTF and B10d see MTTF / B10d Certificate

Indication of the MTTF- / B10d value does not represent a binding composition and/or life expectancy assurance; these are simply experiential values with no warranty implications. These declared values also do not extend the expiration period for defect claims or affect it in any way.

Connector Drawings



Wiring Diagrams

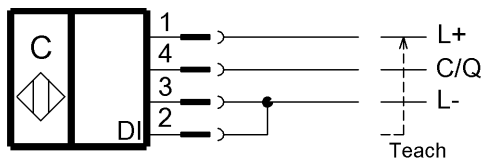

Help Views

Zubehör - Halter
Accessories - Mounting frame

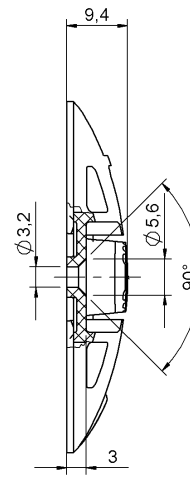
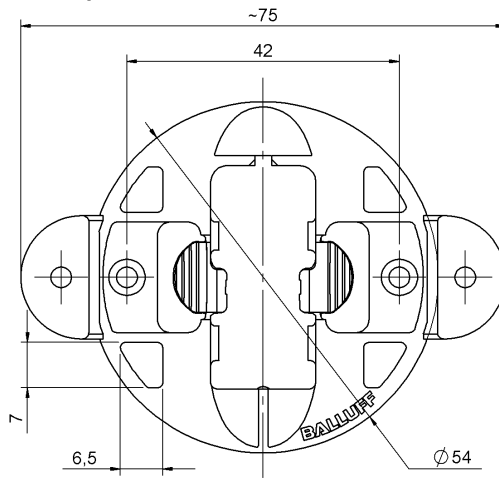

Werkstoff Halter: PP
Material mounting frame: PP