

Velocity Servo BA6301

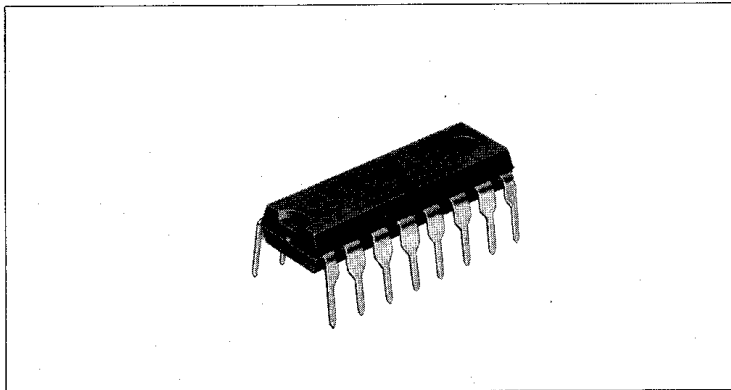

Dimensions (mm)

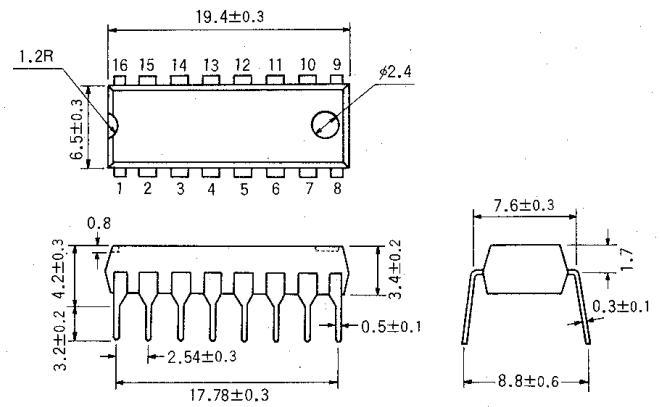

Fig. 1

The BA6301 is a monolithic integrated circuit consisting of a servocontroller which includes in a single package the speed control F/V converter, hysteresis waveform-shaping amplifier, speed-phase controlled output mixer required for use in VTR motor control applications. To accommodate phase servocontrol and MDA, a mixer-type design is used, enabling use with either phase-lag or phase-lead servos.

The BA6301 operates stably with 5V, 9V or 12V power supplies and is designed for energy-efficient operation. High-accuracy variable step speed control is possible when used with an FG program counter.

Features

1. Speed control using an FG program counter
2. Uses a sample & hold F/V converter.
3. Accurate starts and high speeds
4. Low power consumption
5. Wide operating supply voltage
6. Few externally connected components

Applications

1. VTR capstan motor, drum head motor, and reel motor speed control
2. Tape deck, record player and other speed control applications

Block Diagram

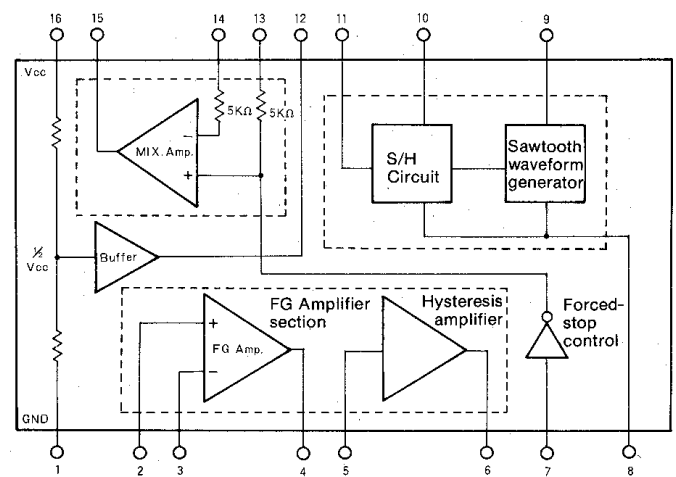

Fig. 2

Absolute Maximum Ratings

Parameter	Symbol	Limits	Unit
Supply voltage	V _{CC}	15	V
Power dissipation	P _d	450*	mW
Operating temperature	T _{opr}	-20~+60	°C
Storage temperature	T _{stg}	-55~+125	°C

* Derating is done at 4.5mW/°C for operation above T_a = 25°C.

Electrical Characteristics (Unless otherwise noted, $T_a = 25^\circ\text{C}$, $V_{CC} = 9\text{V}$)

Parameter	Symbol	Min	Typ	Max	Unit	Conditions
Supply voltage	V_{CC}	4.5	—	13.0	V	
Supply current	I_{CC}	1.5	2.2	3.2	mA	
FG Amplifier section	FG Amplifier loop gain	AV_{O1}	65	75	—	dB $R_{FG} = 100\text{k}\Omega$
	FG Amplifier output level	V_{FGO}	—	2.6	—	V_{p-p}
	Central hysteresis voltage	V_{hyM}	—	1.3	—	V
	Hysteresis voltage width	V_{hyW}	—	± 50	—	mV
	Hysteresis amplifier output level	V_{hyo}	—	7.5	—	V_{p-p} $R_L = 10\text{k}\Omega$
F/V Conversion section	F/V Conversion output temperature coefficient	ΔV_{FVT}	—	0	—	$\% / ^\circ\text{C}$ $V_{RVO} = 4.5\text{V}$
	F/V Conversion output drift voltage	ΔV_{FVD}	—	0	—	$\% / ^\circ\text{C}$ $V_{FVO} = 4.5\text{V}$
	F/V Conversion output ripple voltage	V_{FV} ripple	—	30	—	mV V_{p-p}
	F/V Conversion output level	V_{FVO}	—	7.5	—	V_{p-p} $R_L = 50\text{k}\Omega$
Mixer/amp section	Mixer amplifier open-loop voltage gain	AV_{O2}	—	50	—	dB
	Mixer amplifier output level	V_{MIXO}	—	7.5	—	V_{p-p}
Central bias voltage	V_{Bias}	—	4.5	—	V	
Forced-stop control section	Forced stop threshold level	V_{INTH}	—	2.6	—	V $V_{MIXO} < 1.0\text{V}$
	Input impedance	R_{IN}	—	30	—	$\text{k}\Omega$

Application Example

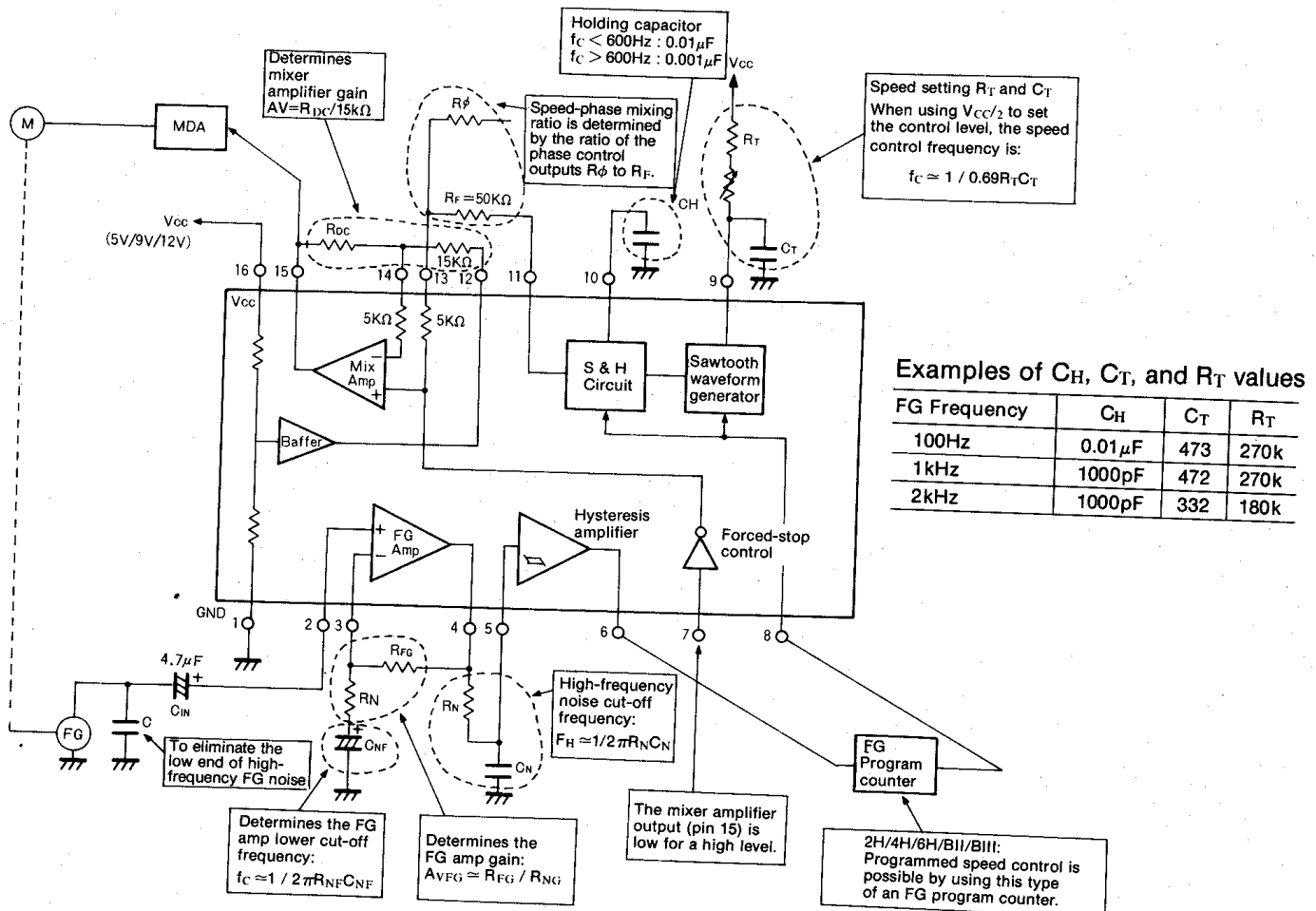

Fig. 3