



SMT current sense transformers

EE 5.0 core

Series/Type: B82801B

Date: October 2012

Application

- Switching power supplies
- Feedback control
- Overload sensing
- Load drop/shut down detection

Features

- Very low DC resistance
- Different turns ratios
- Small package
- Other pinning on request
- RoHS compatible

Marking

Middle block of ordering code

Delivery mode and packing units

- 16 mm blister tape, 330 mm \varnothing reel
- Carton packaging
- Packing units: 900 pcs./reel;
7200 pcs./carton

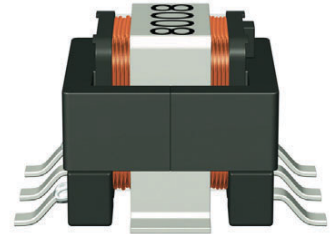

Dimensional drawing

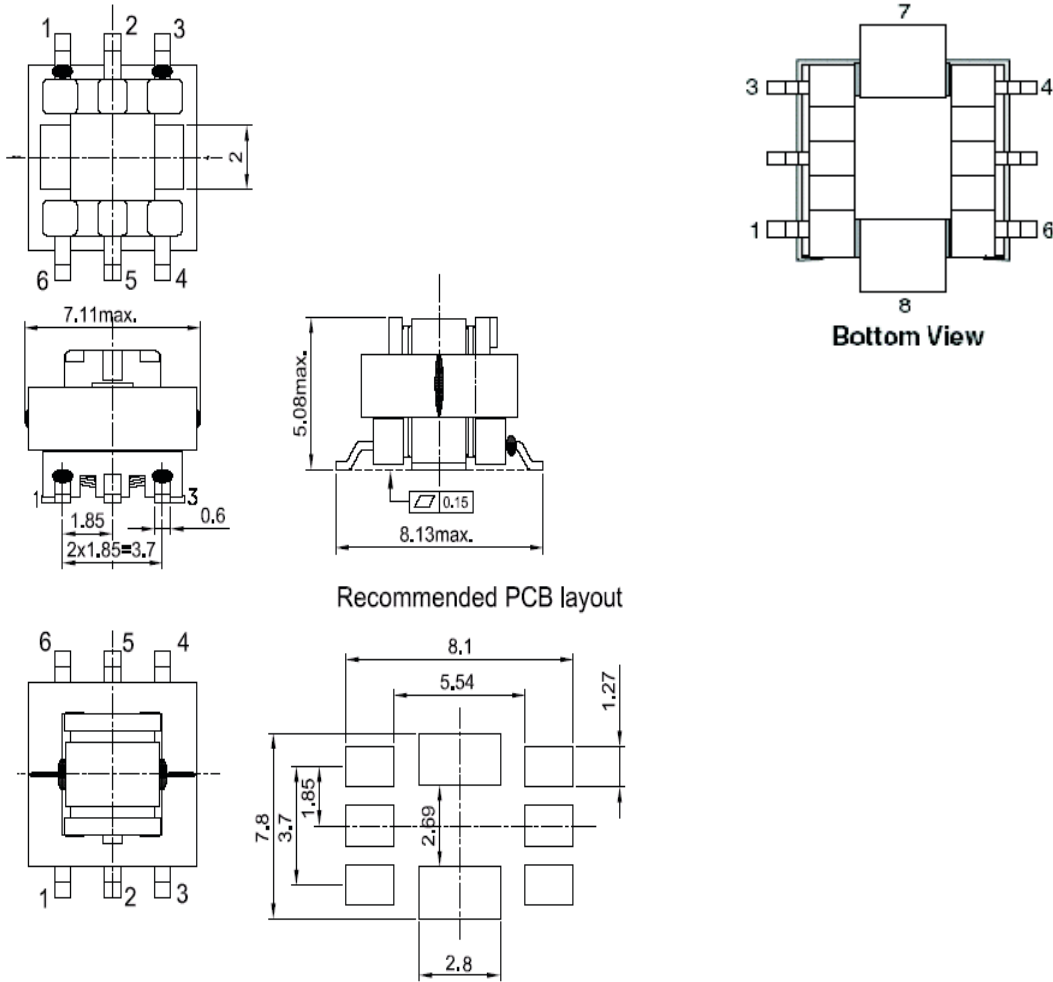

Dimensions in mm

Application circuit and pinning

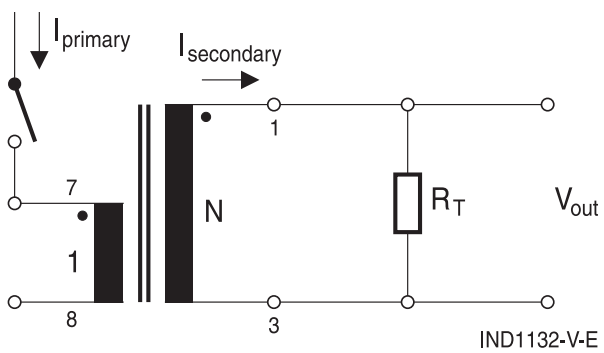

Technical data and measuring conditions

Frequency range	50 kHz ... 1 MHz
Hi-pot	1000 V AC, 2 s (winding to winding)
Inductance L (1-3)	100 kHz, 100 mV, @ +25 °C
DC resistance R_{max}	Measured at +25 °C
Sensed current	The max. primary current of 20 A causes approx. +40 °C temperature rise
Solderability	≥ 99.9 Sn, lead-free. Or Sn96.5Ag3.0Cu0.5: +(245 ±5) °C, (3 ±0.3) s Wetting of soldering area ≥ 95% (to IEC 60068-2-58)
Resistance to soldering heat	+(260 ± 5) °C, (10 ± 1) s to IEC 60068-2-58
Storage conditions	-20 °C ... +40 °C, ≤ 75% RH (packaged)
Test voltage V_{test}	50 Hz, 1 s
Operating temperature range	-40 °C ... +125 °C
Weight	Approx. 0.4 g

$$B_{\max} = \frac{V_{\text{sense,max}} \cdot \delta_{\max}}{n_s \cdot A_e \cdot f_{\text{osc}}}$$

With:

B_{\max} Maximum magnetic flux density in the ferrite core of the current sense transformer

$V_{\text{sense,max}}$ Maximum output voltage of the measurement signal

δ_{\max} Maximum duty cycle

n_s Number of turns of the secondary winding of the current sense transformer

A_e Effective magnetic area of the ferrite core

f_{osc} Operating frequency of the switching operator IC

Typical value for A_e : $2.5 \times 10^{-6} \text{ m}^2$

Typical B_{\max} : 200 mT

$$R_T = \frac{V_{\text{sense,max}} \cdot n_s}{I_{\text{prim,max}}}$$

With:

R_T Resistance of burden resistor

$V_{\text{sense,max}}$ Maximum output voltage of the measurement signal

n_s Number of turns on the secondary side of the CT

$I_{\text{prim,max}}$ Maximum primary current (peak current)

Characteristics and ordering codes

L_{\min} μH	Turns ratio $N_p : N_s$	DC resistance R_{\max} (m Ω)		Voltage- time product $V \cdot \mu\text{s}$	Recomm. R_T Ω	Ordering code
		primary	secondary			
80	1 : 20	0.6	400	10.0	20	B82801B0803A020
180	1 : 30	0.6	870	15.0	30	B82801B0184A030
320	1 : 40	0.6	1140	20.0	40	B82801B0324A040
500	1 : 50	0.6	1500	25.0	50	B82801B0504A050
720	1 : 60	0.6	1980	30.0	60	B82801B0724A060
980	1 : 70	0.6	3000	35.0	70	B82801B0984A070
2000	1 : 100	0.6	5500	50.0	100	B82801B0205A100
3000	1 : 125	0.6	6500	62.5	125	B82801B0305A125
8000	1 : 200	0.6	33240	100.0	200	B82801B0925A200

Taping and packing

Blister tape

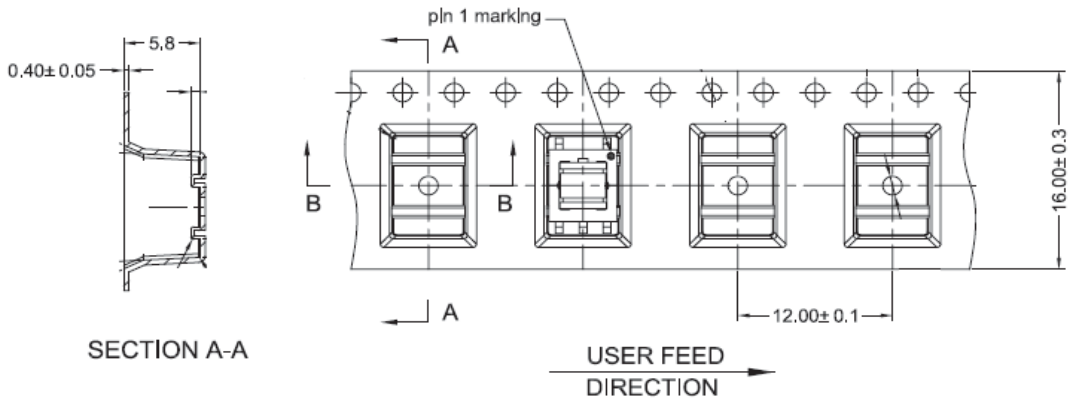

Dimensions in mm

Reel

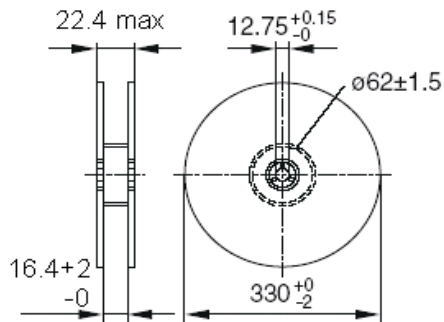

Dimensions in mm

Recommended reflow soldering curve

Pb-free solder material (based on JEDEC J-STD 020D)

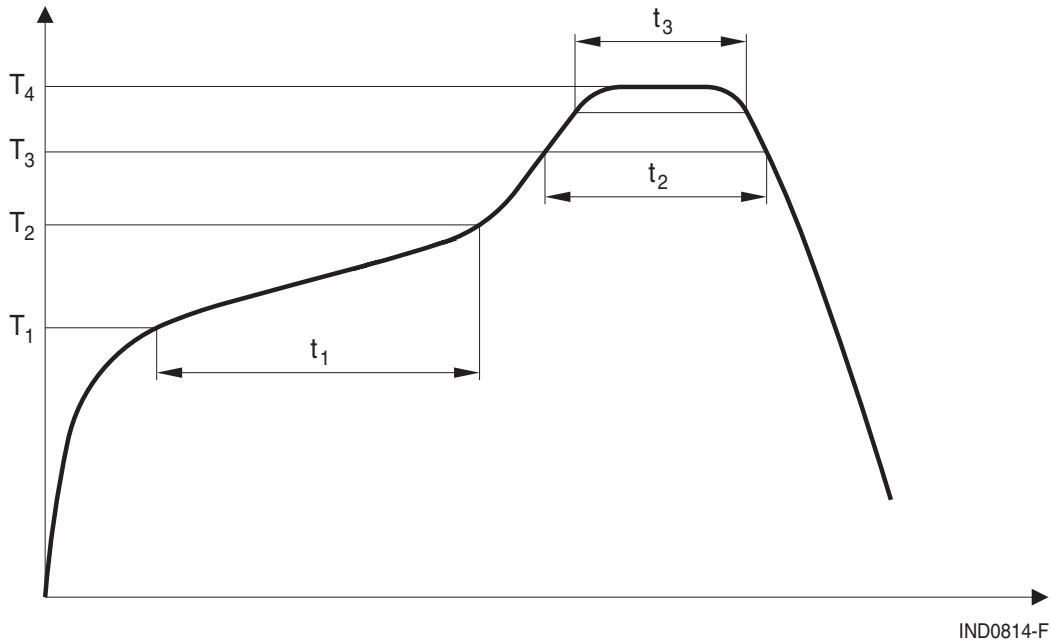

T₁ °C	T₂ °C	T₃ °C	T₄ °C	T₁ sec	T₂ sec	T₃ sec
150	200	217	245	<110	<90	20 ... 40

Max. time from +25 °C to T: 300 seconds

Max. 3 reflow cycles

Cautions and warnings

- Please note the recommendations in our Inductors data book (latest edition) and in the data sheets.
 - Particular attention should be paid to the derating curves given there. Derating must be applied in case the ambient temperature in the application exceeds the rated temperature of the component.
 - Ensure the operation temperature (which is the sum of the ambient temperature and the temperature rise caused by losses / self-heating) of the component in the application does not exceed the maximum value specified in the climatic category.
 - The soldering conditions should also be observed. Temperatures quoted in relation to wave soldering refer to the pin, not the housing.
- If the components are to be washed varnished it is necessary to check whether the washing varnish agent that is used has a negative effect on the wire insulation, any plastics that are used, or on glued joints. In particular, it is possible for washing varnish agent residues to have a negative effect in the long-term on wire insulation.

Washing processes may damage the product due to the possible static or cyclic mechanical loads (e.g. ultrasonic cleaning). They may cause cracks to develop on the product and its parts, which might lead to reduced reliability or lifetime.
- The following points must be observed if the components are potted in customer applications:
 - Many potting materials shrink as they harden. They therefore exert a pressure on the plastic housing or core. This pressure can have a deleterious effect on electrical properties, and in extreme cases can damage the core or plastic housing mechanically.
 - It is necessary to check whether the potting material used attacks or destroys the wire insulation, plastics or glue.
 - The effect of the potting material can change the high-frequency behaviour of the components.
- Ferrites are sensitive to direct impact. This can cause the core material to flake, or lead to breakage of the core.
- Even for customer-specific products, conclusive validation of the component in the circuit can only be carried out by the customer.

Important notes

The following applies to all products named in this publication:

1. Some parts of this publication contain **statements about the suitability of our products for certain areas of application**. These statements are based on our knowledge of typical requirements that are often placed on our products in the areas of application concerned. We nevertheless expressly point out **that such statements cannot be regarded as binding statements about the suitability of our products for a particular customer application**. As a rule, EPCOS is either unfamiliar with individual customer applications or less familiar with them than the customers themselves. For these reasons, it is always ultimately incumbent on the customer to check and decide whether an EPCOS product with the properties described in the product specification is suitable for use in a particular customer application.
2. We also point out that **in individual cases, a malfunction of electronic components or failure before the end of their usual service life cannot be completely ruled out in the current state of the art, even if they are operated as specified**. In customer applications requiring a very high level of operational safety and especially in customer applications in which the malfunction or failure of an electronic component could endanger human life or health (e.g. in accident prevention or life-saving systems), it must therefore be ensured by means of suitable design of the customer application or other action taken by the customer (e.g. installation of protective circuitry or redundancy) that no injury or damage is sustained by third parties in the event of malfunction or failure of an electronic component.
3. **The warnings, cautions and product-specific notes must be observed.**
4. In order to satisfy certain technical requirements, **some of the products described in this publication may contain substances subject to restrictions in certain jurisdictions (e.g. because they are classed as hazardous)**. Useful information on this will be found in our Material Data Sheets on the Internet (www.epcos.com/material). Should you have any more detailed questions, please contact our sales offices.
5. We constantly strive to improve our products. Consequently, **the products described in this publication may change from time to time**. The same is true of the corresponding product specifications. Please check therefore to what extent product descriptions and specifications contained in this publication are still applicable before or when you place an order.

We also **reserve the right to discontinue production and delivery of products**. Consequently, we cannot guarantee that all products named in this publication will always be available. The aforementioned does not apply in the case of individual agreements deviating from the foregoing for customer-specific products.

6. Unless otherwise agreed in individual contracts, **all orders are subject to the current version of the “General Terms of Delivery for Products and Services in the Electrical Industry” published by the German Electrical and Electronics Industry Association (ZVEI)**.
7. The trade names EPCOS, BAOKE, Alu-X, CeraDiode, CeraLink, CSMP, CSSP, CTVS, DeltaCap, DigiSiMic, DSSP, FilterCap, FormFit, MiniBlue, MiniCell, MKD, MKK, MLSC, MotorCap, PCC, PhaseCap, PhaseCube, PhaseMod, PhiCap, SIFERRIT, SIFI, SIKOREL, SilverCap, SIMDAD, SiMic, SIMID, SineFormer, SIOV, SIP5D, SIP5K, ThermoFuse, WindCap are **trademarks registered or pending** in Europe and in other countries. Further information will be found on the Internet at www.epcos.com/trademarks.