



## **Ferrites and accessories**

**P 36 × 22**

**Core and accessories**

**Series/Type: B65611, B65612, B65615, B65679**

**Date: September 2006 / August 2007**

**P 36 × 22**

**Core**

**B65611**

■ Delivery mode: sets

**Magnetic characteristics (per set)**

	with center hole	without center hole	
$\Sigma l/A$	0.26	0.25	mm <sup>-1</sup>
$l_e$	52	53.5	mm
$A_e$	202	213	mm <sup>2</sup>
$A_{min}$	—	173	mm <sup>2</sup>
$V_e$	10500	11400	mm <sup>3</sup>

**Approx. weight (per set)**

m	57	59.5	g

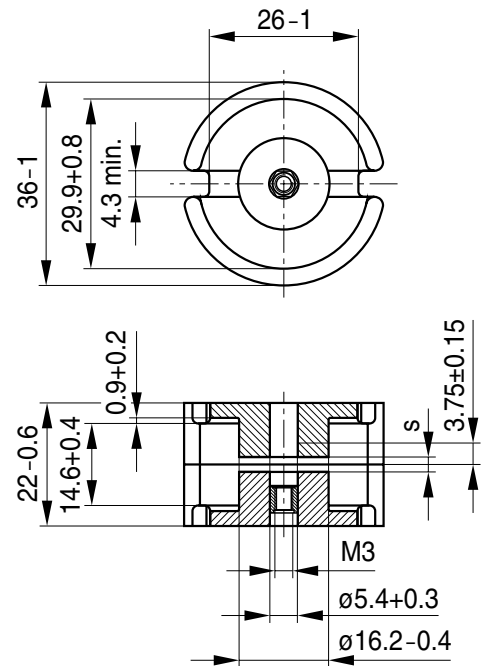

FPK0358-W

**Gapped**

Material	$A_L$ value nH	s approx. mm	$\mu_e$	Ordering code <sup>1)</sup> -D with center hole -T with threaded sleeve
N48	250 ±3%	1.20	51	B65611+0250A048
	400 ±3%	0.62	82	B65611+0400A048
	630 ±3%	0.35	129	B65611+0630A048
	1000 ±3%	0.22	205	B65611+1000A048

**Ungapped**

Material	$A_L$ value nH	$\mu_e$	Ordering code -D with center hole -W without center hole
N48	7600 +30/-20%	1560	B65611D0000R048
N30	15200 +30/-20%	3040	B65611W0000R030

1) Replace the + by the code letter "D" or "T" for the required version.

**Coil former**

Standard: to IEC 60133

Material: GFR polyterephthalate (UL 94 V-0, insulation class to IEC 60085:  
 $F \triangleq$  max. operating temperature 155 °C), color code black  
 Valox 420-SE0® [E45329 (M)], GE PLASTICS B V

Winding: see Data Book 2007, chapter “Processing notes, 2.1”

**Insulating washer between core and coil former**

- For tolerance compensation and for insulation
- Polycarbonate spring washer (UL 94 V-0, insulation class to IEC 60085:  $E \triangleq$  120 °C), 0.08 mm thick  
 Aryphan F685, [E167358 (M)], natural color, LOFO HIGH TECH FILM GMBH

Coil former				Ordering code
Sections	$A_N$ mm <sup>2</sup>	$l_N$ mm	$A_R$ value $\mu\Omega$	
1	63	73	39	B65612B0000T001
Insulating washer (reel packing, PU = 1 reel)				B65612A5000X000

**Coil former**

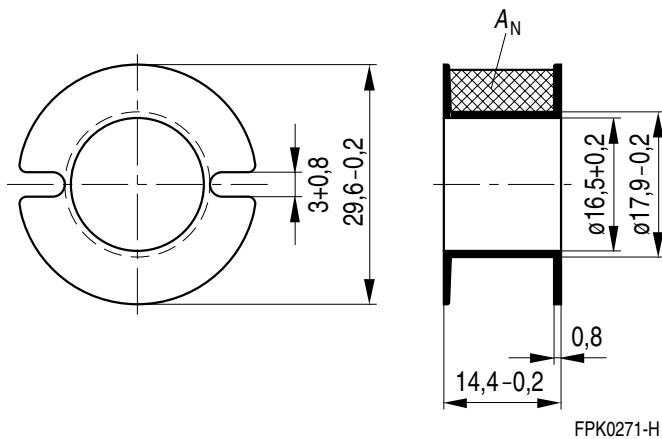

**Insulating washer**  
(preliminary data)

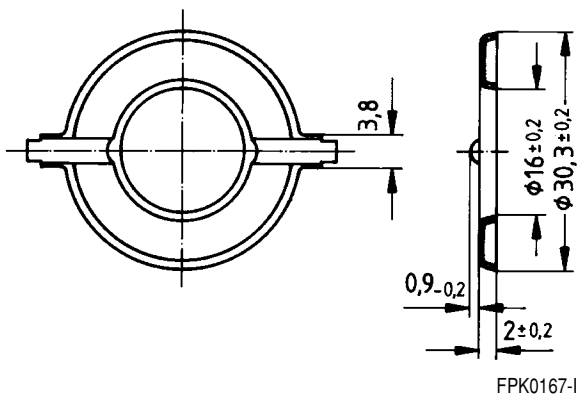

### Mounting assembly for printed circuit boards

- The set comprises a terminal carrier and a yoke

#### Terminal carrier

Material: GFR polyterephthalate (UL 94 V-0, insulation class to IEC 60085: F  $\hat{=}$  max. operating temperature 155 °C), color code black  
 Pocan B4235® [E245249 (M)], LANXESS AG

Solderability: to IEC 60068-2-20, test Ta, method 1 (aging 3): 235 °C, 2 s

Resistance to soldering heat: to IEC 60068-2-20, test Tb, method 1B: 350 °C, 3.5 s

#### Yoke

Spring yoke, made of nickel silver (0.6 mm), with ground terminal

Complete mounting assembly (10 solder terminals)

Ordering code: B65615B0001X000

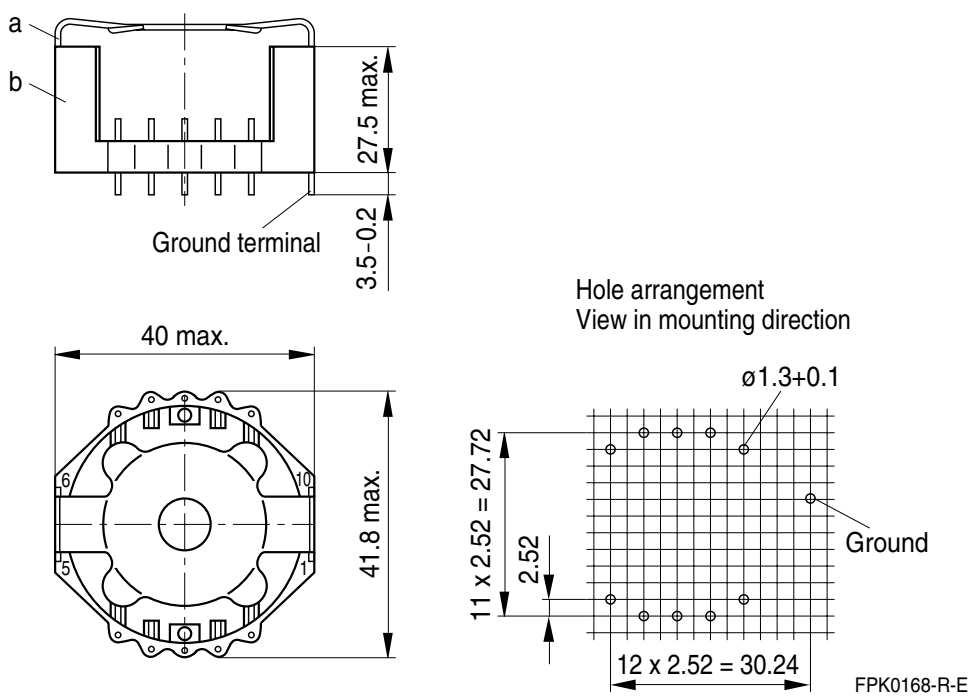

- a) Yoke
- b) Terminal carrier with 10 solder terminals

### Adjusting screw

- Tube core with thread and core brake made of GFR polyterephthalate  
Pocan B3235® [E245249 (M)], LANXESS AG

Tube core			Ordering code
Ø × length (mm)	Material	Color code	
4.55 × 6.3	N22	red	B65679E0003X022
4.98 × 6.3	N22	black	B65679E0002X022

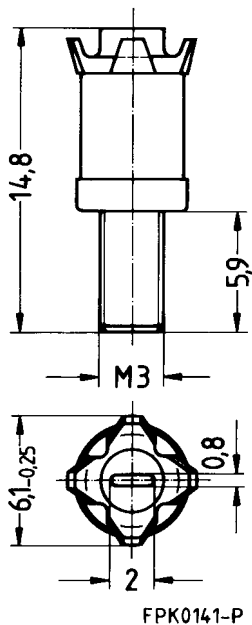

### Note:

Due to the limited distance between adjusting screw and internal borehole, the entire assembly must be accurately centered.

### **Mechanical stress and mounting**

Ferrite cores have to meet mechanical requirements during assembling and for a growing number of applications. Since ferrites are ceramic materials one has to be aware of the special behavior under mechanical load.

As valid for any ceramic material, ferrite cores are brittle and sensitive to any shock, fast changing or tensile load. Especially high cooling rates under ultrasonic cleaning and high static or cyclic loads can cause cracks or failure of the ferrite cores.

For detailed information see Data Book 2007, chapter “General – Definitions, 8.1”.

### **Effects of core combination on $A_L$ value**

Stresses in the core affect not only the mechanical but also the magnetic properties. It is apparent that the initial permeability is dependent on the stress state of the core. The higher the stresses are in the core, the lower is the value for the initial permeability. Thus the embedding medium should have the greatest possible elasticity.

For detailed information see Data Book 2007, chapter “General – Definitions, 8.2”.

### **Heating up**

Ferrites can run hot during operation at higher flux densities and higher frequencies.

### **NiZn-materials**

The magnetic properties of NiZn-materials can change irreversible in high magnetic fields.

### **Processing notes**

- The start of the winding process should be soft. Else the flanges may be destroyed.
- To strong winding forces may blast the flanges or squeeze the tube that the cores can no more be mount.
- To long soldering time at high temperature (>300 °C) may effect coplanarity or pin arrangement.
- Not following the processing notes for soldering of the J-leg terminals may cause solderability problems at the transformer because of pollution with Sn oxyd of the tin bath or burned insulation of the wire. For detailed information see Data Book 2007, chapter “Processing notes, 2.2”.
- The dimensions of the hole arrangement have fixed values and should be understood as a recommendation for drilling the printed circuit board. For dimensioning the pins, the group of holes can only be seen under certain conditions, as they fit into the given hole arrangement. To avoid problems when mounting the transformer, the manufacturing tolerances for positioning the customers’ drilling process must be considered by increasing the hole diameter.

## Important notes

The following applies to all products named in this publication:

1. Some parts of this publication contain **statements about the suitability of our products for certain areas of application**. These statements are based on our knowledge of typical requirements that are often placed on our products in the areas of application concerned. We nevertheless expressly point out **that such statements cannot be regarded as binding statements about the suitability of our products for a particular customer application**. As a rule, EPCOS is either unfamiliar with individual customer applications or less familiar with them than the customers themselves. For these reasons, it is always ultimately incumbent on the customer to check and decide whether an EPCOS product with the properties described in the product specification is suitable for use in a particular customer application.
2. We also point out that **in individual cases, a malfunction of passive electronic components or failure before the end of their usual service life cannot be completely ruled out in the current state of the art, even if they are operated as specified**. In customer applications requiring a very high level of operational safety and especially in customer applications in which the malfunction or failure of a passive electronic component could endanger human life or health (e.g. in accident prevention or life-saving systems), it must therefore be ensured by means of suitable design of the customer application or other action taken by the customer (e.g. installation of protective circuitry or redundancy) that no injury or damage is sustained by third parties in the event of malfunction or failure of a passive electronic component.
3. **The warnings, cautions and product-specific notes must be observed.**
4. In order to satisfy certain technical requirements, **some of the products described in this publication may contain substances subject to restrictions in certain jurisdictions (e.g. because they are classed as “hazardous”)**. Useful information on this will be found in our Material Data Sheets on the Internet ([www.epcos.com/material](http://www.epcos.com/material)). Should you have any more detailed questions, please contact our sales offices.
5. We constantly strive to improve our products. Consequently, **the products described in this publication may change from time to time**. The same is true of the corresponding product specifications. Please check therefore to what extent product descriptions and specifications contained in this publication are still applicable before or when you place an order.  
We also **reserve the right to discontinue production and delivery of products**. Consequently, we cannot guarantee that all products named in this publication will always be available.
6. Unless otherwise agreed in individual contracts, **all orders are subject to the current version of the “General Terms of Delivery for Products and Services in the Electrical Industry” published by the German Electrical and Electronics Industry Association (ZVEI)**.
7. The trade names EPCOS, EPCOS-JONES, Baoke, Alu-X, CeraDiode, CSSP, MLSC, PhaseCap, PhaseMod, SIFI, SIFERRIT, SIKOREL, SilverCap, SIMID, SIOV, SIP5D, SIP5K, UltraCap, WindCap are **trademarks registered or pending** in Europe and in other countries. Further information will be found on the Internet at [www.epcos.com/trademarks](http://www.epcos.com/trademarks).