



Film Capacitors – Power Factor Correction

Key components – Capacitor contactors

Series/Type: B44066S
Ordering code: B44066S...J230/J110/N230/N110
Date: July 2012
Version: 11

Characteristics

- Excellent damping of inrush current
- Improved power quality (e.g. avoidance of voltage sags)
- Longer useful life of main contacts of capacitor contactor
- Soft switching of capacitor and thus longer useful life
- Enhanced mean life expectancy
- Reduced ohmic losses
- Easy access for cable connection
- AC6b utilization category for switching 3-phase capacitors for B44066S****J***
- Approvals
 - cUL approval
 - CCC (China Compulsory Certification) up to 75 kvar



B44066S....J230/J110



B44066S9010J230



B44066S...N230/N110



B44066S1810J230/J110



B44066S1810N230/N110

Series B44066S...J230/J110 for conventional PFC-systems without reactors

Features	
Resistors	Tamper-proof and protected
Leading contacts	With wiper function
Pre-contacts	Snap function
Aux-contacts	For all types
Usage	In applications with or without reactors

Series B44066S...N230/N110 for de-tuned PFC-systems with reactors

Features	
Aux-contacts	For all types
Usage	In applications with reactors only

Type / Main contacts		B44066S1810...	B44066S2410...	B44066S3210...	B44066S5010...
Capacitor power at 50 °C ■ 380 ... 400 V ■ 415 ... 440 V ■ 660 ... 690 V	kvar	0 ... 12.5 0 ... 13 0 ... 20	10 ... 20 10.5 ... 22 17 ... 33	10 ... 25 10.5 ... 27 17 ... 41	20 ... 33.3 23 ... 36 36 ... 55
Capacitor power at 60 °C ■ 380 ... 400 V ■ 415 ... 440 V ■ 660 ... 690 V	kvar	0 ... 12.5 0 ... 13 0 ... 20	10 ... 20 10.5 ... 22 17 ... 33	10 ... 25 10.5 ... 27 17 ... 41	20 ... 33.3 23 ... 36 36 ... 55
Coil operating voltage at 50 Hz ¹⁾ : ■ Type ... 230 ■ Type ... 110 ■ Type ... 400	V AC	220 ... 240 110 N/A	220 ... 240 110 N/A	220 ... 240 110 380 ... 415	220 ... 240 On request N/A
Coil operating voltage at 60 Hz ¹⁾ : ■ Type ... 230 ■ Type ... 110 ■ Type ... 400	V AC	230 ... 264 110 ... 120 N/A	230 ... 264 110 ... 120 N/A	230 ... 264 110 ... 120 400 ... 440	230 ... 264 On request N/A
Rated op. current AC6b at 50/60 Hz ■ 50 °C ■ 60 °C	A	0 ... 18 0 ... 18	14 ... 28 14 ... 28	14 ... 36 14 ... 36	30 ... 48 30 ... 48
Power loss contactor at max. rated capacitor current	W	4.1	5.7	7.5	12.6
Rated insulation voltage	V AC	690 ¹⁾	690 ¹⁾	690 ¹⁾	690 ¹⁾
Max. frequency of operations:	1/h	120	120	120	120
Contact life: ■ without reactors ■ with reactors	Million operations	0.25 0.40	0.15 0.30	0.15 0.30	0.15 0.30
Cable cross section for contactors without thermal overload relay 1 cable per clamp Main connector ■ Solid or stranded ■ Flexible ■ Flexible with multicore cable end 2 cables per clamp ■ Solid or stranded ■ Flexible	mm ² mm ² mm ² mm ² mm ²	0.75 – 6 1 – 4 0.75 – 4 6+(1-6) / 4+(0.75-4) 2.5+(0.75-2.5) / 1.5+(0.75-1.5) 6+(1.5-6) / 4+(1-4) 2.5+(0.75-2.5) / 1.5+(0.75-1.5)	1.5 – 25 2.5 – 16 1.5 – 16 16+(2.5-6) / 10+(4-10) 6+(4-6) / 4+(2.5-4) 16+(2.5-6) / 10+(4-10) 6+(4-6) / 4+(2.5-4)	1.5 – 25 2.5 – 16 1.5 – 16 16+(2.5-6) / 10+(4-10) 6+(4-6) / 4+(2.5-4) 16+(2.5-6) / 10+(4-10) 6+(4-6) / 4+(2.5-4)	4 – 50 10 – 35 6 – 35 50+4 / 35+6 / 25+(6-16) 16+(6-16) / 10+(6-16) 50+(4-10) / 35+(4-16) 25+(4-25) / 16+(4-16)
Cables per clamp		2	2	2	2

1) Suitable at 690 V for: earthed-neutral systems, overvoltage category I to IV, pollution degree 3 (standard-industry): $V_{imp} = 8 \text{ kV}$.
Data for other conditions on request.

2) Operating range of magnet-coils $0.85 V_s$ (min. value of rated control voltage) up to $1.1 \cdot V_s$ (max. value of rated control voltage).

Type/Main contacts		B44066S1810...	B44066S2410...	B44066S3210...	B44066S5010...
For main connector					
■ Solid AWG		18 – 10	16 – 10	16 – 10	12 – 10
■ Flexible AWG		18 – 10	14 – 4	14 – 4	10 – 0
Cables per clamp		2	1	1	1
■ Solid AWG	mm ²	10+(16-10) / 12+(18-12) 14+(18-14) / 16+(18-16)	10+(16-10) / 12+(18-12) 14+(18-14) / 16+(18-16)	10+(16-10) / 12+(18-12) 14+(18-14) / 16+(18-16)	10+(12-10) / 12+12
■ Flexible AWG	mm ²	10+(14-10) / 12+(18-12) 14+(18-14) / 16+(18-16)	4+(18-12) / 6+(18-8) 8+(18-8) / 10+(18-12)	4+(18-12) / 6+(18-8) 8+(18-8) / 10+(18-12)	1+(12-10) / 2+(8-12) 3+(12-8) / 4+(10-6)
Cables per clamp		2	2	2	2
Weight including auxiliary contact:					
■ Type ...N...	kg	0.26	0.51	0.51	0.88
■ Type ...J...		0.37	0.67	0.67	1.03
Fuses gL (gG) from / to	A	35 / 63	50 / 80	63 / 100	80 / 160
Auxiliary contacts					
Normal Open (NO)		1	1	1	1
Rated insulation voltage	V AC	690 ²⁾	690 ²⁾	690 ²⁾	690 ²⁾
Rated operational current AC15 at 230 V / 400 V	A	3 / 2	3 / 2	3 / 2	3 / 2
Rated operational current AC1 at 690 V	A	10	10	10	10

1) Suitable at 690 V for: earthed-neutral systems, overvoltage category I to IV, pollution degree 3 (standard-industry): $V_{imp} = 8$ kV. Data for other conditions on request.

2) Operating range of magnet-coils $0.85 V_s$ (min. value of rated control voltage) up to $1.1 \cdot V_s$ (max. value of rated control voltage).

Type/Main contacts		B44066S6210...	B44066S7410...	B44066S9010...	B44066S9910...
Capacitor power at 50 °C ■ 380 ... 400 V ■ 415 ... 440 V ■ 660 ... 690 V	kvar	20 ... 50 23 ... 53 36 ... 82	20 ... 75 23 ... 75 36 ... 120	33...80 36...82 57...120	33 ... 100 36 ... 103 57 ... 148
Capacitor power at 60 °C ■ 380 ... 400 V ■ 415 ... 440 V ■ 660 ... 690 V	kvar	20 ... 50 23 ... 53 36 ... 82	20 ... 60 23 ... 64 36 ... 100	33...75 36...77 57...120	33 ... 90 36 ... 93 57 ... 148
Coil operating voltage at 50 Hz ¹⁾ : ■ Type ... 230 ■ Type ... 110 ■ Type ... 400	V AC	220 ... 240 110 380 ... 415	220 ... 240 110 N/A	220 ... 240 On request N/A	220 ... 240 On request N/A
Coil operating voltage at 60 Hz ¹⁾ : ■ Type ... 230 ■ Type ... 110 ■ Type ... 400	V AC	230 ... 264 110 ... 120 400 ... 440	230 ... 264 110 ... 120 N/A	277 On request N/A	277 On request N/A
Rated op. current AC6b at 50/60 Hz ■ 50 °C ■ 60 °C	A	30 ... 72 30 ... 72	30 ... 108 30 ... 87	50 ... 115 50 ... 108	50 ... 144 50 ... 130
Power loss contactor at max. rated capacitor current	W	21	38.7	29	36
Rated insulation voltage	V AC	690 ¹⁾	690 ¹⁾	1000 ¹⁾	1000 ¹⁾
Max. frequency of operations:	1/h	120	80	80	80
Contact life: ■ without reactors ■ with reactors	Million operations	0.15 0.30	0.12 0.20	0.12 0.20	0.12 0.20
Cable cross section for contactors without thermal overload relay; 1 cable per clamp Main connector ■ Solid or stranded ■ Flexible ■ Flexible with multicore cable end	mm ² mm ² mm ²	4 – 50 10 – 35 6 – 35	4 – 50 10 – 35 6 – 35		
2 cables per clamp ■ Solid or stranded	mm ²	50+4 / 35+6 / 25+(6-16) / 16+(6-16) / 10+(6-16)	50+4 / 35+6 / 25+(6-16) / 16+(6-16) / 10+(6-16)	Top 0.5–95+10 Below 120	Top 0.5–95+10 Below 120
■ Flexible	mm ²	50+(4-10) / 35+(4-16) / 25+(4-25) / 16+(4-16)	50+(4-10) / 35+(4-16) / 25+(4-25) / 16+(4-16)	05–70+10–95	05–70+10–95
Cables per clamp For main connector ■ Solid AWG ■ Flexible AWG	mm ² mm ²	2 12 – 10 10 – 0	2 12 – 10 10 – 0	1+1	1+1
Cables per clamp ■ Solid AWG	mm ²	1 10+(12-10) / 12+12	1 10+(12-10) / 12+12	Top 18–10 Below –	Top 18–10 Below –
■ Flexible AWG	mm ²	1+(12-10) / 2+(8-12) / 3+(12-8) / 4+(10-6)	1+(12-10) / 2+(8-12) / 3+(12-8) / 4+(10-6)	Top 18–30 Below 8–4/0	Top 18–30 Below 8–4/0
Cables per clamp		2	2	1+1	1+1

1) Suitable at 690 V for: earthed-neutral systems, overvoltage category I to IV, pollution degree 3 (standard-industry): $V_{imp} = 8 \text{ kV}$.
Data for other conditions on request.

2) Operating range of magnet-coils $0.85 V_s$ (min. value of rated control voltage) up to $1.1 \cdot V_s$ (max. value of rated control voltage).

Type/Main contacts		B44066S6210...	B44066S7410...	B44066S9010...	B44066S9910...
Weight including auxiliary contact:					
■ Type ...N...	kg	0.88	0.88	2.2	2.23
■ Type ...J...		1.03	1.03	2.3	2.33
Fuses gL (gG) from / to	A	125/160	160/200	160/200	160/250

Auxiliary contacts

Normal Open (NO)		1	1	1	1
Rated insulation voltage	V AC	690 ²⁾	690 ²⁾	690 ²⁾	690 ²⁾
Rated operational current AC15 at 230 V / 400 V	A	3 / 2	3 / 2	3 / 2	3 / 2
Rated operational current AC1 at 690 V	A	10	10	10	10

1) Suitable at 690 V for: earthed-neutral systems, overvoltage category I to IV, pollution degree 3 (standard-industry): $V_{imp} = 8$ kV.
Data for other conditions on request.

2) Operating range of magnet-coils $0.85 V_s$ (min. value of rated control voltage) up to $1.1 \cdot V_s$ (max. value of rated control voltage).

Connection diagram for all types B44066S...J...

(with preload resistors). B44066S1810J230, B44066S9010J230 and B44066S9910J230 with resistors inside housing.

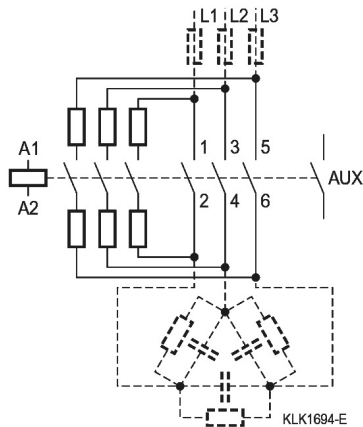

Connection diagram for all types B44066S...N...

(without preload resistors)

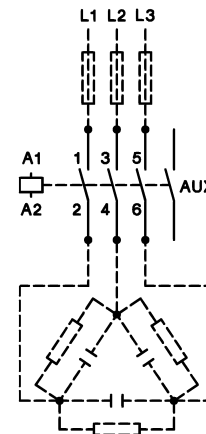

Dimensional drawings

B44066S1810J230, B44066S1810J110
with wires on the bottom only



B44066S1810N230

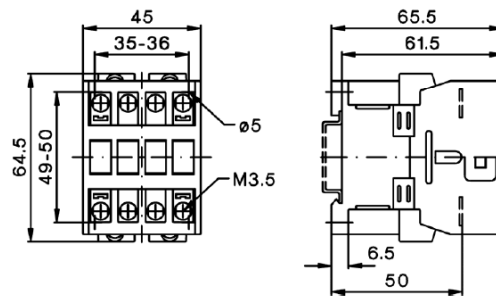

B44066S2410J230, B44066S3210J230
B44066S2410J110, B44066S3210J110

B44066S2410N230, B44066S3210N230

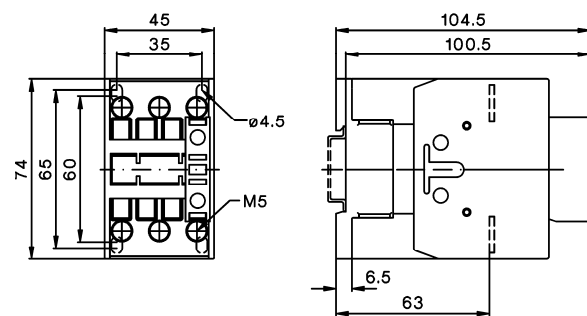
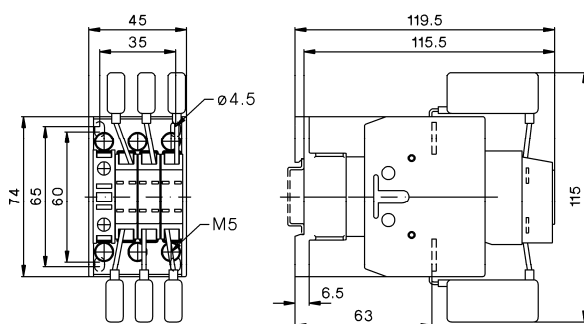

FILM P PM

July 2012

B44066S5010J230, B44066S6210J230,
B44066S6210J110, B44066S7410J230,
B44066S7410J110

B44066S5010N230, B44066S6210N230,
B44066S7410N230

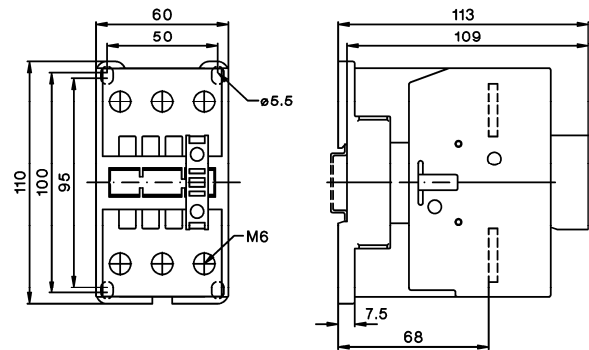
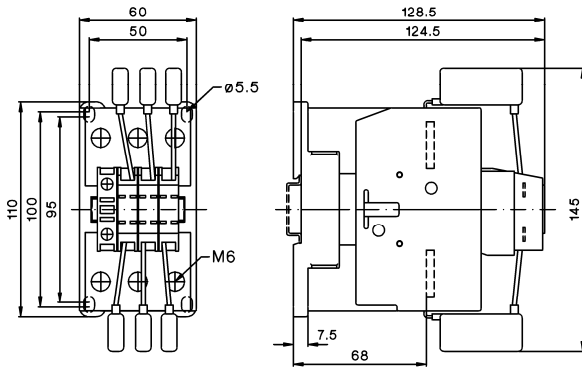

B44066S9010J230, B44066S9910J230

B44066S9010N230, B44066S9910N230

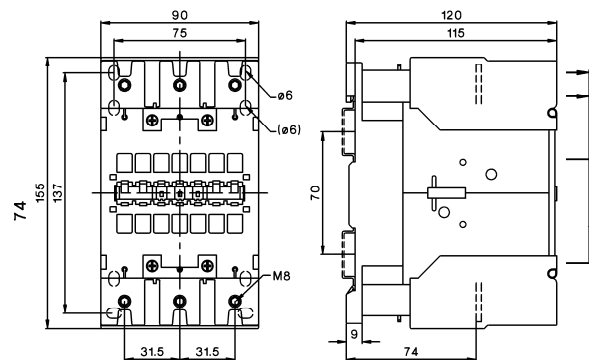
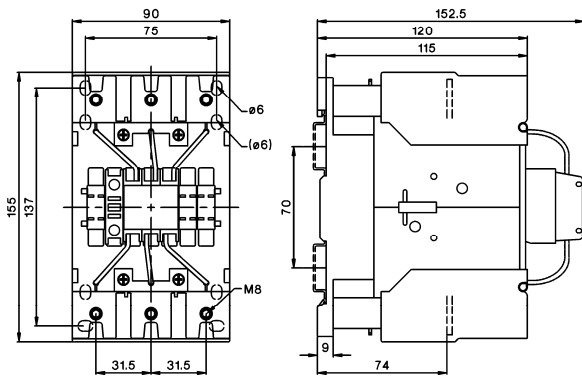

Cautions and warnings

In case auxiliary contacts are used for switching of discharge resistors (not in accordance with IEC 60831 standard), make sure that the current of the discharge resistors is not higher than the rated current of the auxiliary contacts.

Mounting instructions

In the area of capacitor switching contactors, difficultly inflammable and self-extinguishing materials may be used only, because abnormal temperatures within the area of the resistance spirals cannot be excluded.

Note

For detailed information about PFC key components and cautions, refer to the latest version of EPCOS PFC Product Profile.

Please refer to “Installation and Maintenance Instructions for Capacitor Contactors”, available in the Internet. Important: Please note that the „General Safety Recommendations for Power Capacitors“ by ZVEI (German Electrical and Electronic Manufacturers’ Association (ZVEI) have to be observed in addition to the caution guidelines stated in the data sheet (Internet: www.epcos.com/pfc).

Important notes

The following applies to all products named in this publication:

1. Some parts of this publication contain **statements about the suitability of our products for certain areas of application**. These statements are based on our knowledge of typical requirements that are often placed on our products in the areas of application concerned. We nevertheless expressly point out **that such statements cannot be regarded as binding statements about the suitability of our products for a particular customer application**. As a rule, EPCOS is either unfamiliar with individual customer applications or less familiar with them than the customers themselves. For these reasons, it is always ultimately incumbent on the customer to check and decide whether an EPCOS product with the properties described in the product specification is suitable for use in a particular customer application.
2. We also point out that **in individual cases, a malfunction of electronic components or failure before the end of their usual service life cannot be completely ruled out in the current state of the art, even if they are operated as specified**. In customer applications requiring a very high level of operational safety and especially in customer applications in which the malfunction or failure of an electronic component could endanger human life or health (e.g. in accident prevention or life-saving systems), it must therefore be ensured by means of suitable design of the customer application or other action taken by the customer (e.g. installation of protective circuitry or redundancy) that no injury or damage is sustained by third parties in the event of malfunction or failure of an electronic component.
3. **The warnings, cautions and product-specific notes must be observed.**
4. In order to satisfy certain technical requirements, **some of the products described in this publication may contain substances subject to restrictions in certain jurisdictions (e.g. because they are classed as hazardous)**. Useful information on this will be found in our Material Data Sheets on the Internet (www.epcos.com/material). Should you have any more detailed questions, please contact our sales offices.
5. We constantly strive to improve our products. Consequently, **the products described in this publication may change from time to time**. The same is true of the corresponding product specifications. Please check therefore to what extent product descriptions and specifications contained in this publication are still applicable before or when you place an order. We also **reserve the right to discontinue production and delivery of products**. Consequently, we cannot guarantee that all products named in this publication will always be available. The aforementioned does not apply in the case of individual agreements deviating from the foregoing for customer-specific products.
6. Unless otherwise agreed in individual contracts, **all orders are subject to the current version of the "General Terms of Delivery for Products and Services in the Electrical Industry" published by the German Electrical and Electronics Industry Association (ZVEI)**.
7. The trade names EPCOS, BAOKE, Alu-X, CeraDiode, CSMP, CSSP, CTVS, DeltaCap, DigiSiMic, DSSP, FormFit, MiniBlue, MiniCell, MKD, MKK, MLSC, MotorCap, PCC, PhaseCap, PhaseCube, PhaseMod, PhiCap, SIFERRIT, SIFI, SIKOREL, SilverCap, SIMDAD, SiMic, SIMID, SineFormer, SIOV, SIP5D, SIP5K, ThermoFuse, WindCap are **trademarks registered or pending** in Europe and in other countries. Further information will be found on the Internet at www.epcos.com/trademarks.