



SAW Components

Data Sheet X 6965 D





SAW Components

X 6965 D

Bandpass Filter

44,00 MHz

Data Sheet

Duroplast package **SIP5D**

Features

- IF filter for digital cable TV
- Standard IC package

Terminals

- Tinned CuFe alloy

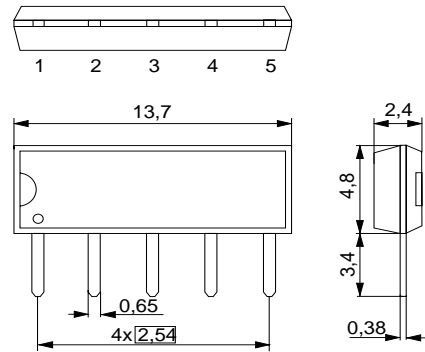

Dimensions in mm, approx. weight 0,5 g

Pin configuration

- 1 Input
- 2 Input - ground
- 3 Chip carrier - ground
- 4 Output
- 5 Output

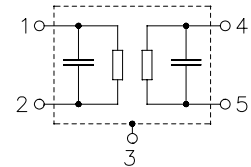

Type	Ordering code	Marking and package according to	Packing according to
X 6965 D	B39440-X6965-N201	C61157-A1-A21	F61074-V8049-Z000

Maximum ratings

Operable temperature range	T_A	-25/+65	°C	
Storage temperature range	T_{stg}	-40/+85	°C	
DC voltage	V_{DC}	5	V	between any terminals
AC voltage	V_{pp}	10	V	between any terminals



SAW Components	X 6965 D
Bandpass Filter	44,00 MHz

Data Sheet

Characteristics

Reference temperature: $T_A = 25 (45) ^\circ\text{C}$
 Terminating source impedance: $Z_S = 50 \Omega$
 Terminating load impedance: $Z_L = 2 \text{ k}\Omega \parallel 3 \text{ pF}$

		min.	typ.	max.	
Center frequency (center between 3 dB points)	f_C	—	(44,00)	—	MHz
Insertion attenuation Reference level for the following data	α 44,06 (44,00) MHz	13,2	14,7	16,2	dB
Pass bandwidth $\alpha_{\text{rel}} \leq 3 \text{ dB}$	$B_{3\text{dB}}$	—	6,0	—	MHz
$\alpha_{\text{rel}} \leq 30 \text{ dB}$	$B_{30\text{dB}}$	—	7,6	—	MHz
Amplitude ripple 41,53 ... 46,59 MHz	$\Delta\alpha$	—	0,4	—	dB
Relative attenuation 41,53 (41,47) MHz	α_{rel}	—	0,3	—	dB
46,59 (46,53) MHz		—	0,4	—	dB
41,06 (41,00) MHz		1,5	2,7	3,8	dB
47,06 (47,00) MHz		1,8	3,0	4,2	dB
47,31 (47,25) MHz		—	8,3	—	dB
39,81 (39,75) MHz		40,0	55,0	—	dB
Lower sidelobe 35,06 ... 39,46 (35,00 ... 39,40) MHz		43,0	47,0	—	dB
39,46 ... 40,06 (39,40 ... 40,00) MHz		38,0	47,0	—	dB
Upper sidelobe 48,06 ... 50,06 (48,00 ... 50,00) MHz		37,0	42,0	—	dB
50,06 ... 55,06 (50,00 ... 55,00) MHz		43,0	51,0	—	dB
Reflected wave signal suppression 1,3 μs ... 6,0 μs after main pulse (test pulse 250 ns, carrier frequency 44,06 MHz)		42,0	52,0	—	dB
Feedthrough signal suppression 1,3 μs ... 1,2 μs before main pulse (test pulse 250 ns, carrier frequency 44,06 MHz)		50,0	56,0	—	dB
Group delay ripple (p-p) 41,53 ... 46,59 MHz	$\Delta\tau$	—	30	—	ns
Impedance at 44,06 MHz Input: $Z_{\text{IN}} = R_{\text{IN}} \parallel C_{\text{IN}}$ Output: $Z_{\text{OUT}} = R_{\text{OUT}} \parallel C_{\text{OUT}}$		—	1,3 16,1 1,1 5,6	—	k Ω pF k Ω pF
Temperature coefficient of frequency	TC_f	—	-72	—	ppm/K



SAW Components

X 6965 D

Bandpass Filter

44,00 MHz

Data Sheet

Frequency response

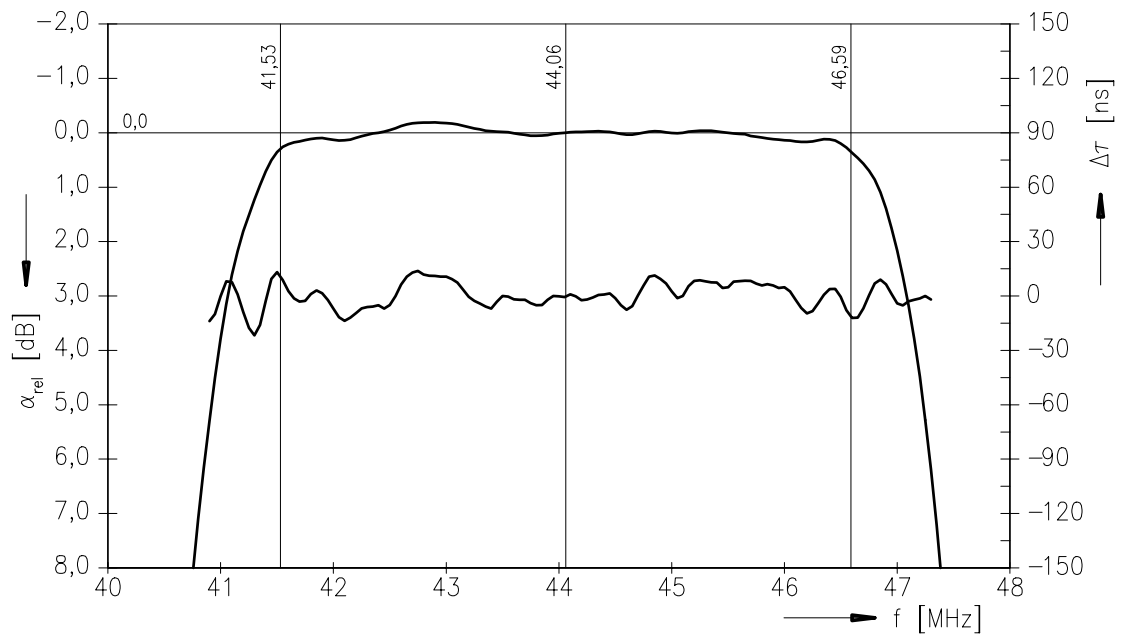
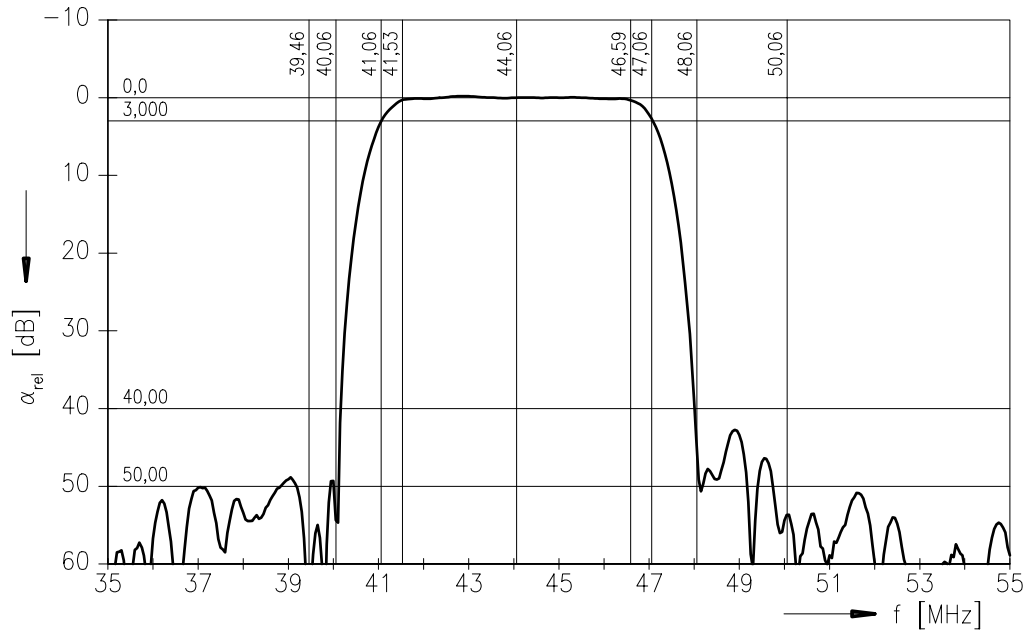



SAW Components

X 6965 D

Bandpass Filter

44,00 MHz

Data Sheet

Frequency response

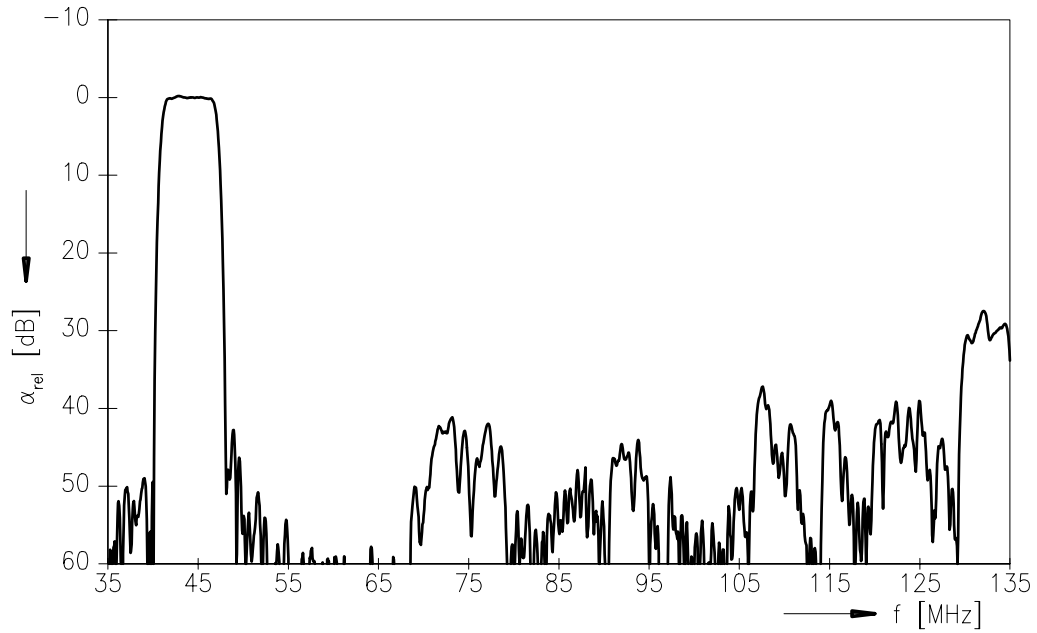

Time domain response

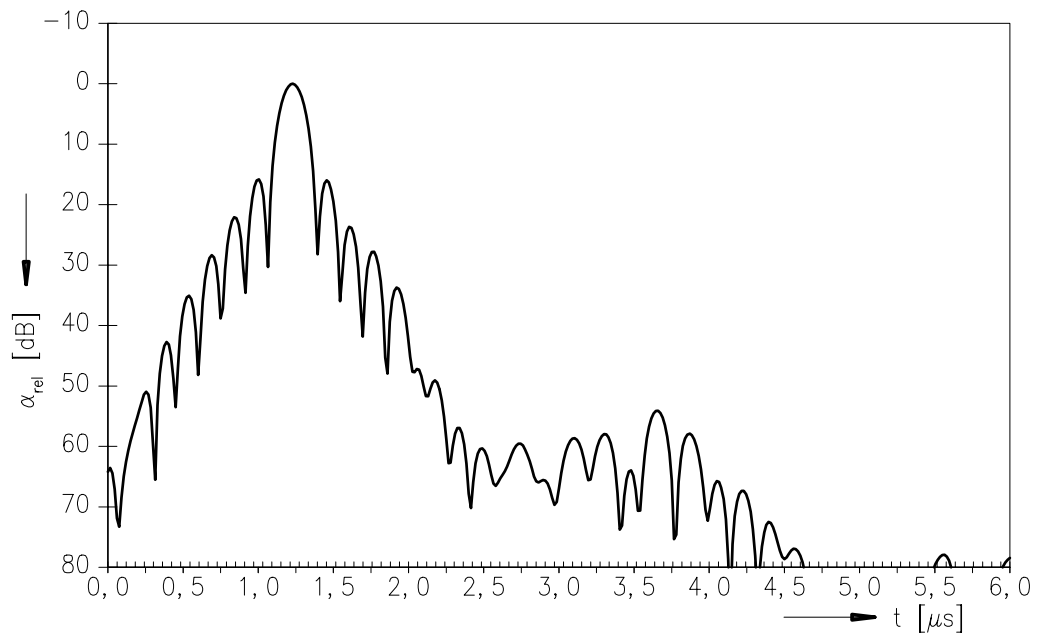



SAW Components

X 6965 D

Bandpass Filter

44,00 MHz

Data Sheet

ished by EPCOS AG

Surface Acoustic Wave Components Division, SAW CE MM PD

P.O. Box 80 17 09, 81617 Munich, GERMANY

© EPCOS AG 2003. Reproduction, publication and dissemination of this brochure and the information contained therein without EPCOS' prior express consent is prohibited.

Purchase orders are subject to the General Conditions for the Supply of Products and Services of the Electrical and Electronics Industry recommended by the ZVEI (German Electrical and Electronic Manufacturers' Association), unless otherwise agreed.

This brochure replaces the previous edition.

For questions on technology, prices and delivery please contact the Sales Offices of EPCOS AG or the international Representatives.

Due to technical requirements components may contain dangerous substances. For information on the type in question please also contact one of our Sales Offices.