

# ATV340D30N4E

variable speed drive - 30kW- 400V - 3 phases -  
ATV340 Ethernet



Product availability: Stock - Normally stocked in distribution facility



## Main

Range of product	Altivar Machine ATV340
Product or component type	Variable speed drive
Device application	Machine
Device short name	ATV340
Variant	Standard version
Product destination	Synchronous motors Asynchronous motors
Mounting mode	Wall mount
EMC filter	Integrated 164.04 ft (50 m) EN/IEC 61800-3 category C2 Integrated 492.13 ft (150 m) EN/IEC 61800-3 category C3
IP degree of protection	IP20IEC 61800-5-1 IP20IEC 60529
Degree of protection	UL type 1 UL 508C
Type of cooling	Forced convection
Supply frequency	50...60 Hz +/- 5 %
Phase	3 phase
[Us] rated supply voltage	380...480 V - 15...10 %
Motor power kW	37 kW normal duty 30 kW heavy duty
Maximum Horse Power Rating	50 Hp normal duty 40 hp heavy duty
Line current	66.2 A 380 V with internal line choke normal duty) 57.3 A 480 V with internal line choke normal duty) 66.2 A 380 V with internal line choke heavy duty) 57.3 A 480 V with internal line choke heavy duty) 54.8 A 48.3 A
Prospective line Isc	50 kA
Apparent power	47.6 KVA 480 V normal duty) 40.2 kVA 480 V heavy duty)
Continuous output current	74.5 A 4 kHz normal duty 61.5 A 4 kHz heavy duty
Maximum transient current	89.4 A 60 s normal duty) 89.4 A 2 s normal duty) 92.3 A 60 s heavy duty) 92.3 A 2 s heavy duty)
Asynchronous motor control profile	Variable torque standard Optimized torque mode Constant torque standard
Synchronous motor control profile	Reluctance motor Permanent magnet motor
Speed drive output frequency	0.1...500 Hz
Nominal switching frequency	4 kHz
Switching frequency	2...16 kHz adjustable 4...16 kHz with derating factor
Safety function	STO (safe torque off) SIL 3

The information provided in this documentation contains general descriptions and/or technical characteristics of the performance of the products contained herein. This documentation is not intended as a substitute for and is not to be used for determining suitability or reliability of these products for specific user applications. It is the duty of any such user or integrator to perform the appropriate and complete risk analysis, evaluation and testing of the products with respect to the relevant specific application or use thereof. Neither Schneider Electric Industries SAS nor any of its affiliates or subsidiaries shall be responsible or liable for misuse of the information contained herein.

## Complementary

Number of preset speeds	16 preset speeds
Communication port protocol	Ethernet/IP Modbus TCP Modbus serial
Option card	Slot GP-X digital and analog I/O extension module Slot GP-X output relay extension module Slot GP-ENC 5/12 V digital encoder interface module Slot GP-ENC analog encoder interface module Slot GP-ENC resolver encoder interface module
Output voltage	<= power supply voltage
Permissible temporary current boost	1.5 x I <sub>n</sub> 60 s heavy duty) 1.2 x I <sub>n</sub> 60 s normal duty)
Motor slip compensation	Automatic whatever the load Not available in permanent magnet motor law Adjustable Can be suppressed
Acceleration and deceleration ramps	Linear adjustable separately from 0.01...9999 s S, U or customized
Braking to standstill	By DC injection
Protection type	Thermal protection motor Safe torque off motor Motor phase loss motor Thermal protection drive Safe torque off drive Overheating drive Overcurrent drive Output overcurrent between motor phase and earth drive Output overcurrent between motor phases drive Short-circuit between motor phase and earth drive Short-circuit between motor phases drive Motor phase loss drive DC Bus overvoltage drive Line supply overvoltage drive Line supply undervoltage drive Input supply loss drive Exceeding limit speed drive Break on the control circuit drive
Frequency resolution	Display unit 0.1 Hz Analog input 0.012/50 Hz
Electrical connection	Line side screw terminal 35...50 mm <sup>2</sup> AWG 3...AWG 1 DC bus screw terminal 25...50 mm <sup>2</sup> AWG 4...AWG 1 Motor screw terminal 35...50 mm <sup>2</sup> AWG 3...AWG 1 Control screw terminal 0.75...1.5 mm <sup>2</sup> AWG 18...AWG 16
Connector type	1 x RJ45, Modbus serial on front face 1 x RJ45, Modbus serial HMI on front face 2 x RJ45, Ethernet IP/Modbus TCP on front face
Physical interface	2-wire RS 485 Modbus serial
Transmission frame	RTU Modbus serial
Transmission rate	4800 bps, 9600 bps, 19200 bps, 38.4 Kbps Modbus serial 10/100 Mbit/s Ethernet IP/Modbus TCP
Exchange mode	Half duplex, full duplex, autonegotiation Ethernet IP/Modbus TCP
Data format	8 bits, configurable odd, even or no parity Modbus serial
Type of polarization	No impedance Modbus serial
Number of addresses	1...247 Modbus serial
Method of access	Slave Modbus RTU Slave Modbus TCP
Supply	External supply for digital inputs 24 V DC 19...30 V), <1.25 mA overload and short-circuit protection Internal supply for reference potentiometer (1 to 10 kOhm) 10.5 V DC +/- 5 %, <10 mA overload and short-circuit protection Internal supply for digital inputs and STO 24 V DC 21...27 V), <200 mA overload and short-circuit protection
Local signalling	Local diagnostic 3 LED mono/dual colour) Embedded communication status 5 LED dual colour) Communication module status 2 LED dual colour) Presence of voltage 1 LED red)
Width	8.39 in (213 mm)

Height	25.98 in (660 mm)
Depth	10.31 in (262 mm)
Net weight	61.51 lb(US) (27.9 kg)
Analogue input number	3
Analogue input type	AI1, AI2, AI3 software-configurable voltage 0...10 V DC 31.5 kOhm 12 bits AI1, AI3 software-configurable current 0...20 mA 250 Ohm 12 bits AI1, AI3 software-configurable temperature probe or water level sensor
Discrete input number	10
Discrete input type	STOA, STOB safe torque off, 24 V DC $\leq$ 30 V) $>$ 2.2 kOhm DI7, DI8 programmable as pulse input 0...30 kHz, 24 V DC $\leq$ 30 V) DI1...DI8 programmable, 24 V DC $\leq$ 30 V)4.4 kOhm
Input compatibility	STOA, STOB discrete input level 1 PLC EN/IEC 61131-2 DI1...DI8 discrete input level 1 PLC EN/IEC 61131-2 DI7, DI8 pulse input level 1 PLC IEC 65A-68
Discrete input logic	Positive logic (source) STOA, STOB), $<$ 5 V, $>$ 11 V Positive logic (source) DI1...DI8), $<$ 5 V, $>$ 11 V Negative logic (sink) DI1...DI8), $>$ 16 V, $<$ 10 V Positive logic (source) DI7, DI8), $<$ 0.6 V, $>$ 2.5 V
Analogue output number	2
Analogue output type	Software-configurable voltage AQ1, AQ2 0...10 V DC 470 Ohm 10 bits Software-configurable current AQ1, AQ2 0...20 mA 500 Ohm 10 bits
Discrete output number	2
Input/output type	Logic output DQ- 0...1 kHz, $\leq$ 30 V DC, 100 mA Logic output DQ+ 0...1 kHz, $\leq$ 30 V DC, 100 mA Programmable as pulse output DQ+ 0...30 kHz, $\leq$ 30 V DC, 20 mA
Sampling duration	2 Ms +/- 0.5 ms DI1...DI8) - discrete input 5 Ms +/- 1 ms DI7, DI8) - pulse input 1 Ms +/- 1 ms AI1, AI2, AI3) - analog input 5 ms +/- 1 ms AQ1, AQ2) - analog output
Accuracy	+/- 0.6 % AI1, AI2, AI3 for a temperature variation 60 °C analog input +/- 1 % AQ1, AQ2 for a temperature variation 60 °C analog output
Linearity error	AI1, AI2, AI3 +/- 0.15 % of maximum value analog input AQ1, AQ2 +/- 0.2 % analog output
Relay output number	3
Relay output type	Configurable relay logic R1 fault relay NO/NC 100000 cycles Configurable relay logic R2 sequence relay NO 100000 cycles Configurable relay logic R3 sequence relay NO 100000 cycles
Refresh time	Relay output R1, R2, R3)5 ms +/- 0.5 ms)
Minimum switching current	Relay output R1, R2, R3 5 mA 24 V DC
Maximum switching current	Relay output R1 resistive, $\cos \phi = 1$ 3 A 250 V AC Relay output R1 resistive, $\cos \phi = 1$ 3 A 30 V DC Relay output R1 inductive, $\cos \phi = 0.4$ 7 ms 2 A 250 V AC Relay output R1 inductive, $\cos \phi = 0.4$ 7 ms 2 A 30 V DC Relay output R2, R3 resistive, $\cos \phi = 1$ 5 A 250 V AC Relay output R2, R3 resistive, $\cos \phi = 1$ 5 A 30 V DC Relay output R2, R3 inductive, $\cos \phi = 0.4$ 7 ms 2 A 250 V AC Relay output R2, R3 inductive, $\cos \phi = 0.4$ 7 ms 2 A 30 V DC

## Environment

Isolation	Between power and control terminals
Insulation resistance	$>$ 1 MOhm 500 V DC for 1 minute to earth
Noise level	63.5 dB 86/188/EEC
Power dissipation in W	Natural convection 77 W 380 V 4 kHz heavy duty) Forced convection 640 W 380 V 4 kHz heavy duty) Natural convection 90 W 380 V 4 kHz normal duty) Forced convection 796 W 380 V 4 kHz normal duty)
Volume of cooling air	63402.43 Gal/hr(US) (240 m3/h)
Operating position	Vertical +/- 10 degree
Electromagnetic compatibility	Electrostatic discharge immunity test level 3 IEC 61000-4-2 Radiated radio-frequency electromagnetic field immunity test level 3 IEC 61000-4-3 Electrical fast transient/burst immunity test level 4 IEC 61000-4-4 1.2/50 $\mu$ s - 8/20 $\mu$ s surge immunity test level 3 IEC 61000-4-5 Conducted radio-frequency immunity test level 3 IEC 61000-4-6
Pollution degree	2 EN/IEC 61800-5-1

Vibration resistance	1.5 mm peak to peak 2...13 Hz)IEC 60068-2-6 1 gn 13...200 Hz)IEC 60068-2-6
Shock resistance	15 gn 11 ms, class 3M3 EN/IEC 60721-3-3
Relative humidity	5...95 % without condensation IEC 60068-2-3
Ambient air temperature for operation	122...140 °F (50...60 °C) with current derating heavy duty) 104...140 °F (40...60 °C) with current derating normal duty) 5...122 °F (-15...50 °C) without current derating heavy duty) 5...104 °F (-15...40 °C) without current derating normal duty)
Ambient air temperature for storage	-40...158 °F (-40...70 °C)
Operating altitude	<= 3280.84 ft (1000 m) without 1000...4800 m with current derating 1 % per 100 m
Environmental characteristic	Chemical pollution resistance class 3C3 EN/IEC 60721-3-3 Dust pollution resistance class 3S3 EN/IEC 60721-3-3
Standards	UL 508C EN/IEC 61800-3 Environment 1 category C2 EN/IEC 61800-3 Environment 2 category C3 EN/IEC 61800-3 EN/IEC 61800-5-1 IEC 61000-3-12 IEC 60721-3 IEC 61508 IEC 13849-1
Product certifications	UL TÜV REACH CSA
Marking	CE

## Ordering and shipping details

Category	22183 - ATV340 (30 THRU 100 HP)
Discount Schedule	CP4B
GTIN	00785901751892
Package weight(Lbs)	34.93 kg (77 lb(US))
Returnability	Yes
Country of origin	CN

## Offer Sustainability

Sustainable offer status	Green Premium product
REACH Regulation	<a href="#">REACH Declaration</a>
EU RoHS Directive	Pro-active compliance (Product out of EU RoHS legal scope) <a href="#">EU RoHS Declaration</a>
Mercury free	Yes
RoHS exemption information	<a href="#">Yes</a>
China RoHS Regulation	<a href="#">China RoHS Declaration</a>
Environmental Disclosure	<a href="#">Product Environmental Profile</a>
Circularity Profile	<a href="#">End Of Life Information</a>
WEEE	The product must be disposed on European Union markets following specific waste collection and never end up in rubbish bins.

## Dimensions

Views: Front - Left - Rear

mm  
in

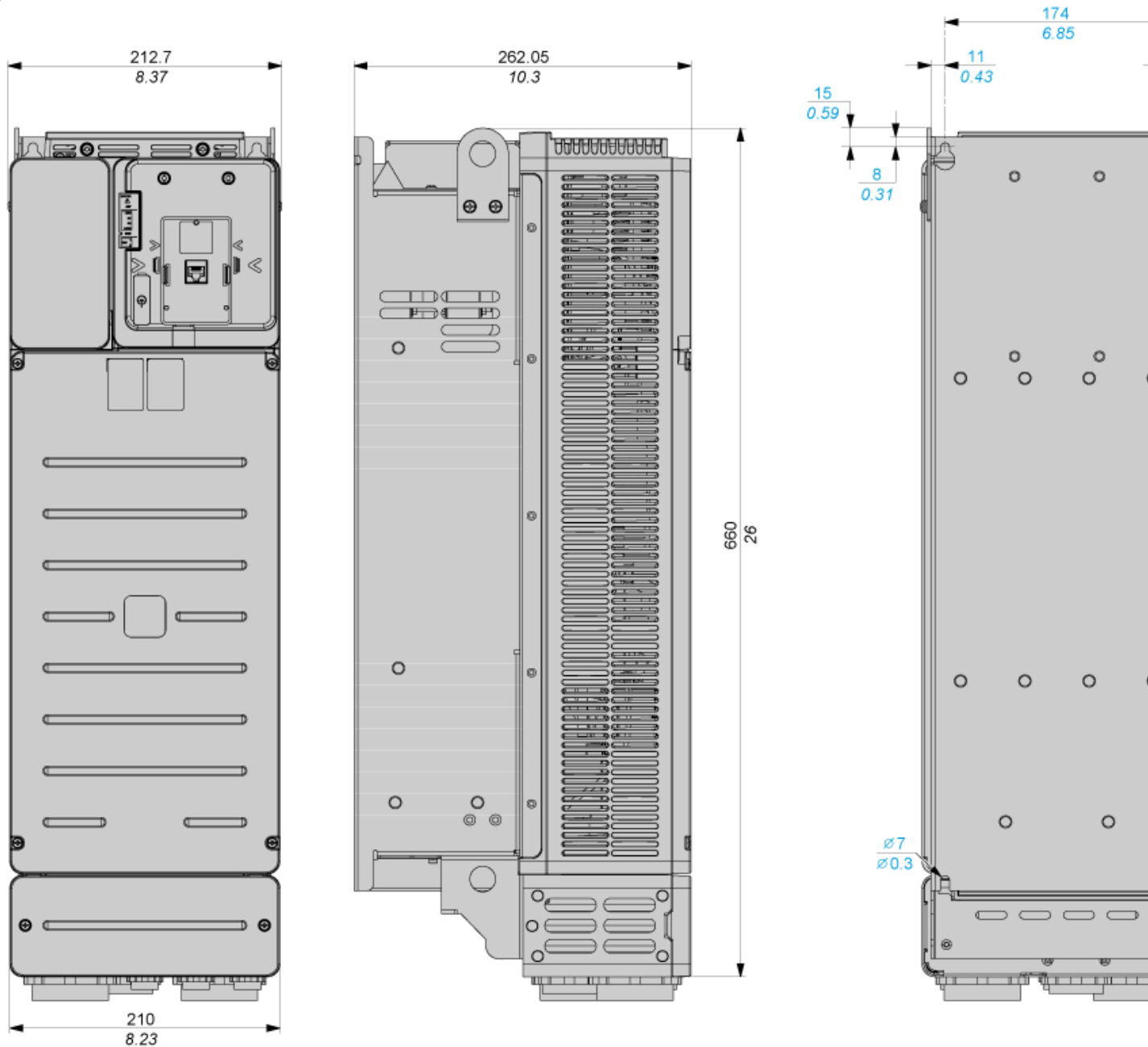

Clearance

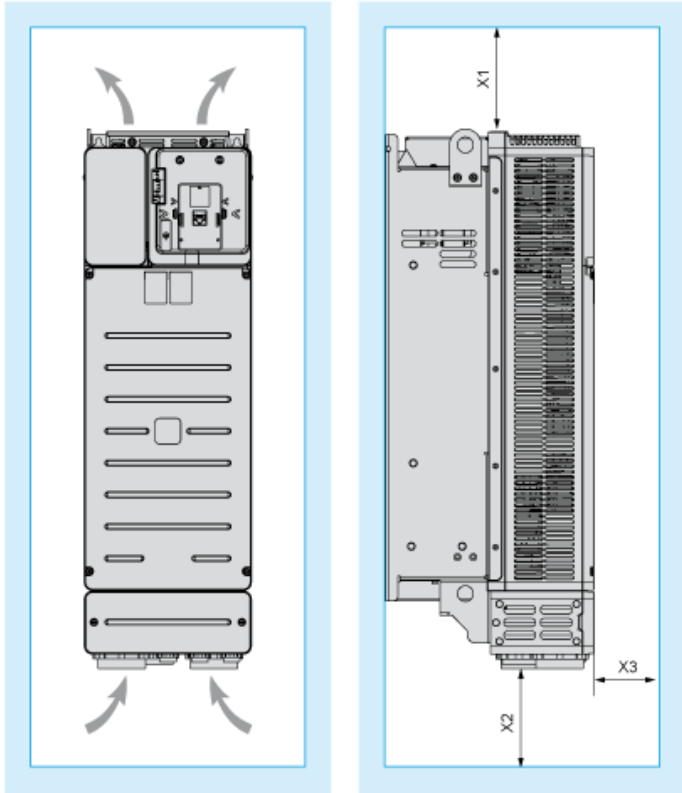

Dimensions in mm

X1	X2	X3
≥ 100	≥ 100	≥ 10

Dimensions in in.

X1	X2	X3
≥ 3.94	≥ 3.94	≥ 0.39

Mounting Types

Mounting Type A: Side by Side IP20

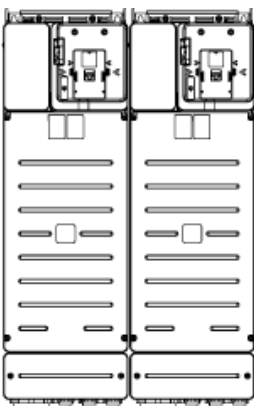

Possible, up to 50 °C, 2 drives only

### Mounting Type B: Individual IP20

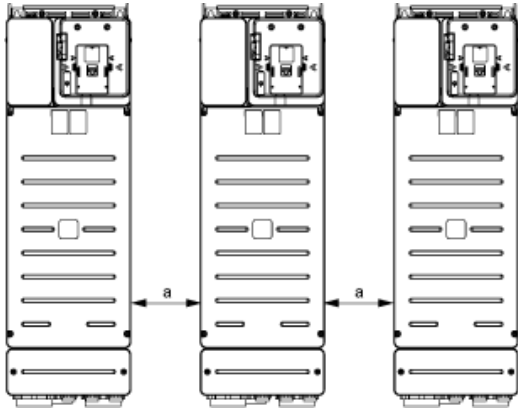

$a \geq 110 \text{ mm (4.33 in.)}$

Connections and Schema

Three-Phase Power Supply with Upstream Breaking via Line Contactor Without Safety Function STO

Connection diagrams conforming to standards ISO13849 category 1 and IEC/EN 61508 capacitySIL1, stopping category 0 in accordance with standard IEC/EN 60204-1.

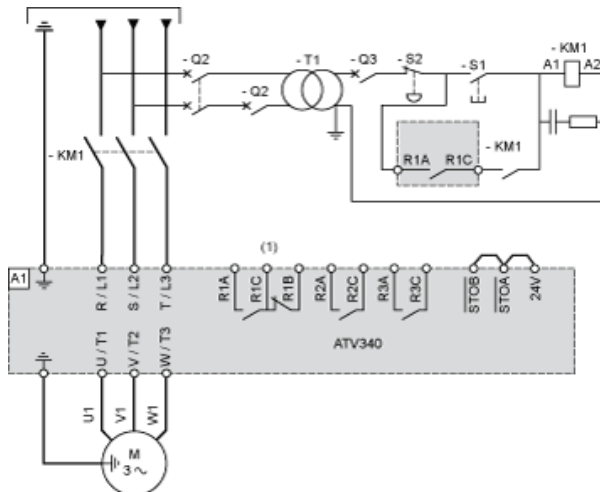

(1) Use relay output R1 set to operating state Fault to switch Off the product once an error is detected.

A1 : Drive

KM1 : Line Contactor

Q2, : Circuit breakers

Q3 :

S1 : Pushbutton

S2 : Emergency stop

T1 : Transformer for control part

Three-Phase Power Supply with Downstream Breaking via Switch Disconnecter

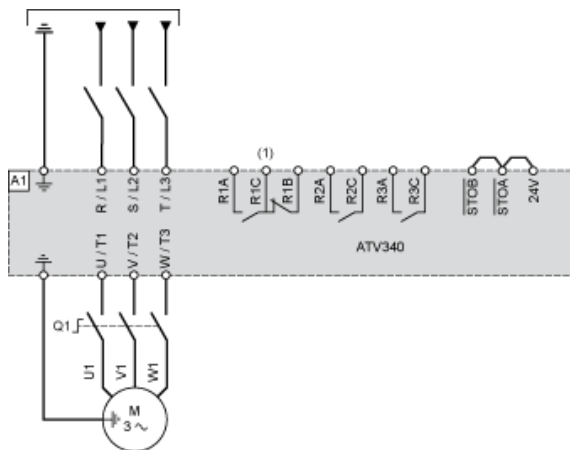

(1) Use relay output R1 set to operating state Fault to switch Off the product once an error is detected.

A1 : Drive

Q1 : Switch disconnecter

## Sensor Connection

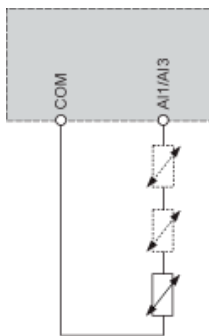

It is possible to connect either 1 or 3 sensors on terminals AI1/AI3.

## Control Block Wiring Diagram

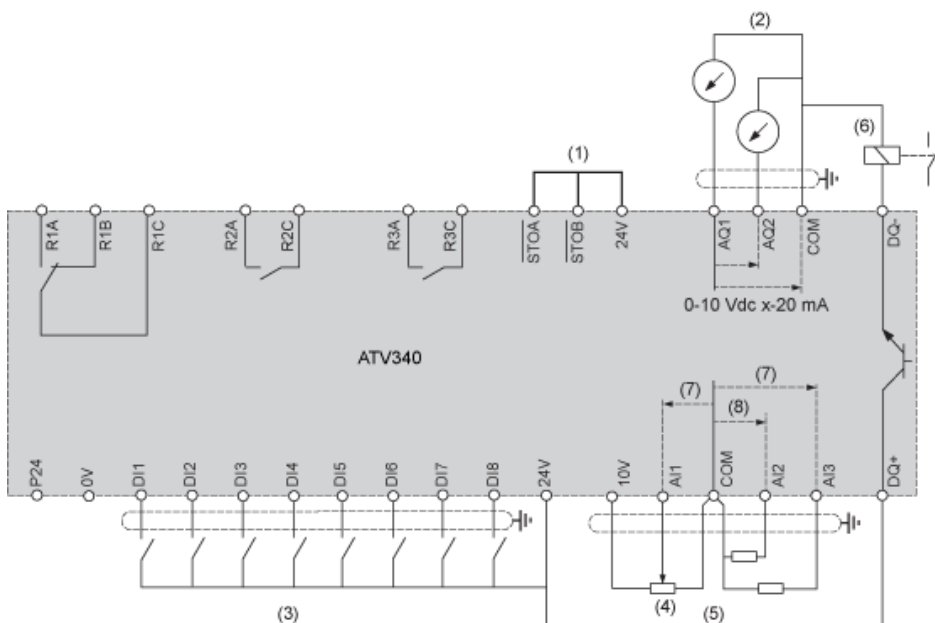

- (1) Safe Torque Off
- (2) Analog Output
- (3) Digital Input
- (4) Reference potentiometer
- (5) Analog Input
- (6) Digital Output
- (7) 0-10 Vdc, x-20 mA
- (8) 0-10 Vdc, -10 Vdc...+10 Vdc

A1 : ATV340 Drive

R1A, Fault relay

R1B,

R1C :

R2A, Sequence relay

R2C :

R3A, Sequence relay

R3C :

## Digital Inputs Wiring

Switch Set to SRC (Source) Position Using the Output Power Supply for the Digital Inputs

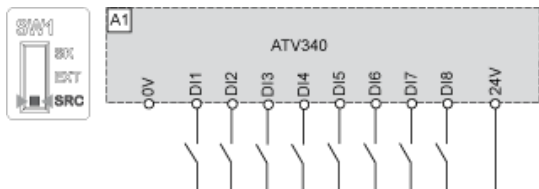

### Switch Set to SRC (Source) Position and Use of an External Power Supply for the DIs

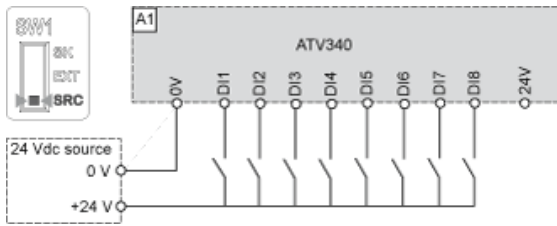

### Switch Set to SK (Sink) Position Using the Output Power Supply for the Digital Inputs

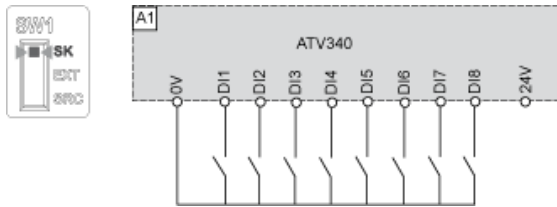

### Switch Set to EXT Position Using an External Power Supply for the DIs

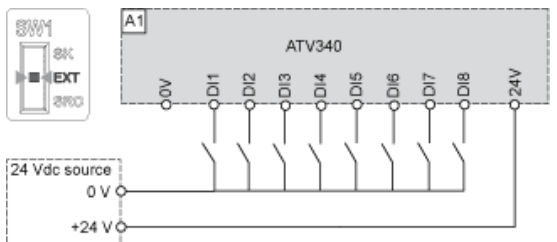

## Digital Outputs Wiring

### Digital Outputs: Internal Supply

Positive Logic, Source, European Style, DQ switches to +24V



(1) Relay or valve

Negative Logic, Sink, Asian Style, DQ switches to 0V

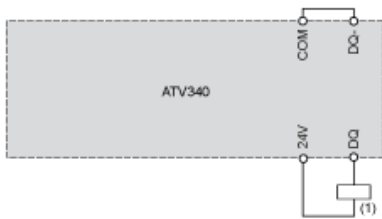

(1) Relay or valve

### Digital Outputs: External Supply

Positive Logic, Source, European Style, DQ switches to +24V

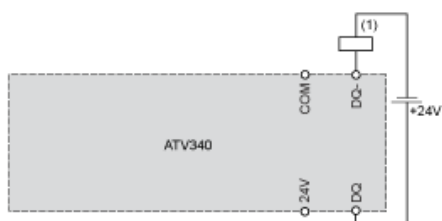

(1) Relay or valve

Negative Logic, Sink, Asian Style, DQ switches to 0V

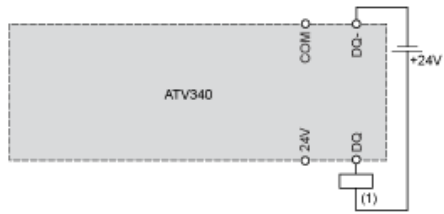

(1) Relay or valve

Open Loop Applications

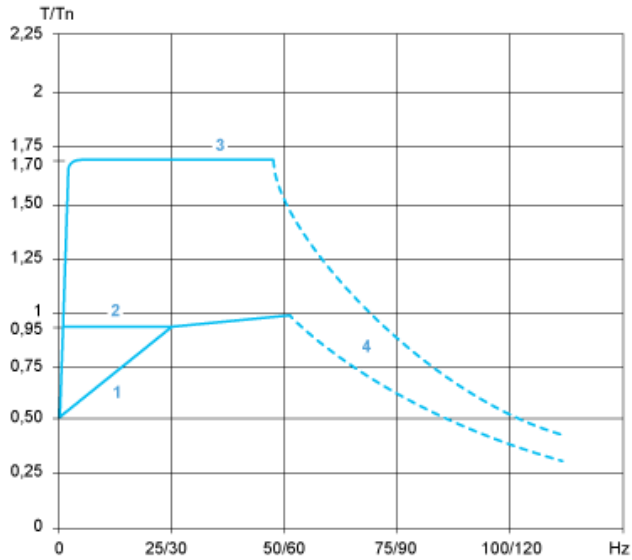

- 1 : Self-cooled motor: continuous useful torque
- 2 : Force-cooled motor: continuous useful torque
- 3 : Overtorque for 60 s maximum
- 4 : Torque in overspeed at constant power

Closed Loop Applications

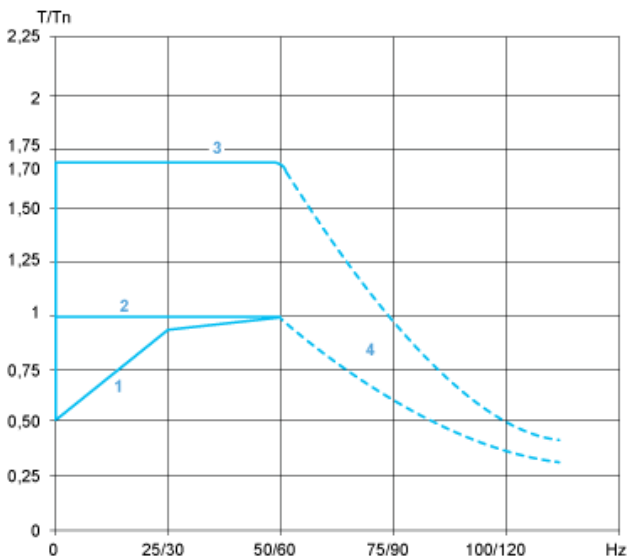

- 1 : Self-cooled motor: continuous useful torque
- 2 : Force-cooled motor: continuous useful torque
- 3 : Overtorque for 60 s maximum
- 4 : Torque in overspeed at constant power