

# ATSU01N232LT

soft starter for asynchronous motor - ATSU01 -  
32 A - 200..480V - 7.5..15 KW



## Main

Range of product	Altistart U01 and TeSys U
Product or component type	Soft starter
Product destination	Asynchronous motors
Product specific application	Simple machine
Device short name	ATSU01
Network number of phases	3 phases
[Us] rated supply voltage	200...480 V - 10...10 %
Motor power kW	15 kW, 3 phases at 400 V 7.5 kW, 3 phases at 230 V
Motor power hp	10 Hp, 3 phases at 230 V 20 hp, 3 phases at 460 V
ICL starter rating	32 A
Utilisation category	AC-53B conforming to EN/IEC 60947-4-2
Current consumption	100 mA
Type of start	Start with voltage ramp
Power dissipation in W	2.5 W at full load and at end of starting 322.5 W in transient state

## Complementary

Assembly style	With heat sink
Function available	Integrated bypass
Supply voltage limits	180...528 V
Supply frequency	50...60 Hz - 5...5 %
Network frequency	47.5...63 Hz
Output voltage	<= power supply voltage
[Uc] control circuit voltage	24 V DC +/- 10 %
Starting time	Adjustable from 1 to 10 s 1 s / 50 10 s / 5 5 s / 10
Deceleration time symb	Adjustable from 1 to 10 s
Starting torque	30...80 % of starting torque of motor connected directly on the line supply
Discrete input type	Logic (LI1, LI2, BOOST) stop, run and boost on start-up functions <= 8 mA 27 kOhm
Discrete input voltage	24...40 V
Input output isolation	Galvanic between power and control
Discrete input logic	Positive LI1, LI2, BOOST at State 0: < 5 V and <= 0.2 mA at State 1: > 13 V, >= 0.5 mA
Discrete output current	2 A DC-13 3 A AC-15
Discrete output type	Open collector logic LO1 end of starting signal Relay outputs R1A, R1C NO
Discrete output voltage	24 V (voltage limits: 6...30 V) open collector logic
Minimum switching current	10 mA at 6 V DC for relay outputs
Maximum switching current	Relay outputs: 2 A at 30 V DC cos phi = 0.5 and L/R = 20 ms inductive load Relay outputs: 2 A at 250 V AC AC-15 cos phi = 0.5 and L/R = 20 ms inductive load
Maximum switching voltage	440 V relay outputs

Display type	1 LED (green) for starter powered up 1 LED (yellow) for nominal voltage reached
Tightening torque	1.9...2.5 N.M 0.5 N.m
Electrical connection	4 mm screw clamp terminal - rigid 1 1...10 mm <sup>2</sup> AWG 8 power circuit Screw connector - rigid 1 0.5...2.5 mm <sup>2</sup> AWG 14 control circuit 4 mm screw clamp terminal - rigid 2 1...6 mm <sup>2</sup> AWG 10 power circuit Screw connector - rigid 2 0.5...1 mm <sup>2</sup> AWG 17 control circuit Screw connector - flexible with cable end 1 0.5...1.5 mm <sup>2</sup> AWG 16 control circuit 4 mm screw clamp terminal - flexible without cable end 1 1.5...10 mm <sup>2</sup> AWG 8 power circuit Screw connector - flexible without cable end 1 0.5...2.5 mm <sup>2</sup> AWG 14 control circuit 4 mm screw clamp terminal - flexible with cable end 2 1...6 mm <sup>2</sup> AWG 10 power circuit 4 mm screw clamp terminal - flexible without cable end 2 1.5...6 mm <sup>2</sup> AWG 10 power circuit Screw connector - flexible without cable end 2 0.5...1.5 mm <sup>2</sup> AWG 16 control circuit
Marking	CE
Operating position	Vertical +/- 10 degree
Height	314 mm
Width	45 mm
Depth	170 mm
Net weight	0.49 kg
Motor power range AC-3	7...11 kW at 200...240 V 3 phases 15...25 kW at 380...440 V 3 phases
Motor starter type	Soft starter

## Environment

Electromagnetic compatibility	Conducted and radiated emissions level B conforming to CISPR 11 Conducted and radiated emissions level B conforming to IEC 60947-4-2 Damped oscillating waves level 3 conforming to IEC 61000-4-12 Electrostatic discharge level 3 conforming to IEC 61000-4-2 EMC immunity conforming to EN 50082-1 EMC immunity conforming to EN 50082-2 Harmonics conforming to IEC 1000-3-2 Harmonics conforming to IEC 1000-3-4 Immunity to electrical transients level 4 conforming to IEC 61000-4-4 Immunity to radiated radio-electrical interference level 3 conforming to IEC 61000-4-3 Voltage/Current impulse level 3 conforming to IEC 61000-4-5 Conducted and radiated emissions level 3 conforming to IEC 61000-4-6 Immunity to conducted interference caused by radio-electrical fields conforming to IEC 61000-4-11
Standards	EN/IEC 60947-4-2
Product certifications	UL CCC CSA C-Tick
IP degree of protection	IP20
Pollution degree	2 conforming to EN/IEC 60947-4-2
Vibration resistance	1 gn (f= 13...150 Hz) conforming to EN/IEC 60068-2-6 1.5 mm peak to peak (f= 3...13 Hz) conforming to EN/IEC 60068-2-6
Shock resistance	15 gn for 11 ms conforming to EN/IEC 60068-2-27
Relative humidity	5...95 % without condensation or dripping water conforming to EN/IEC 60068-2-3
Ambient air temperature for operation	-10...40 °C (without derating) 40...50 °C (with current derating of 2 % per °C)
Ambient air temperature for storage	-25...70 °C conforming to EN/IEC 60947-4-2
Operating altitude	<= 1000 m without derating > 1000 m with current derating of 2.2 % per additional 100 m

## Packing Units

Unit Type of Package 1	PCE
Number of Units in Package 1	1
Package 1 Height	5.5 cm
Package 1 Width	15.2 cm
Package 1 Length	17.5 cm
Package 1 Weight	576.0 g
Unit Type of Package 2	S03
Number of Units in Package 2	14
Package 2 Height	30.0 cm
Package 2 Width	30.0 cm
Package 2 Length	40.0 cm
Package 2 Weight	8.41 kg

## Offer Sustainability

REACH Regulation	<a href="#">REACH Declaration</a>
REACH free of SVHC	Yes
EU RoHS Directive	Pro-active compliance (Product out of EU RoHS legal scope) <a href="#">EU RoHS Declaration</a>
Toxic heavy metal free	Yes
Mercury free	Yes
China RoHS Regulation	<a href="#">China RoHS Declaration</a>
RoHS exemption information	<a href="#">Yes</a>
Circularity Profile	<a href="#">End Of Life Information</a>
WEEE	The product must be disposed on European Union markets following specific waste collection and never end up in rubbish bins

## Contractual warranty

Warranty	18 months
----------	-----------

Dimensions

With TeSys U Combination (Non Reversing Power Base)

Mounting on symmetrical (35 mm) rail with power connector between ATS and TeSys U.

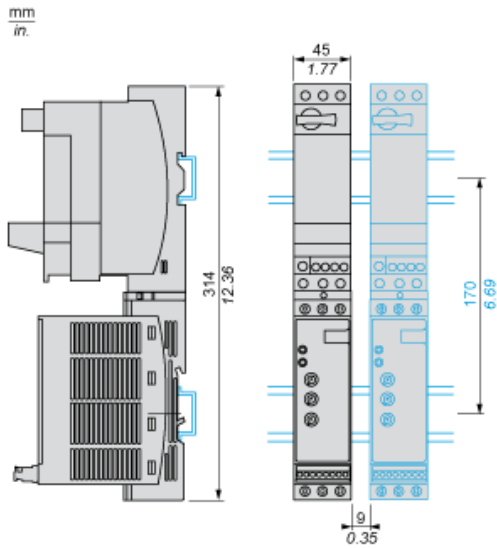

With TeSys U Combination (Non Reversing or Reversing Power Base)

Side by side mounting

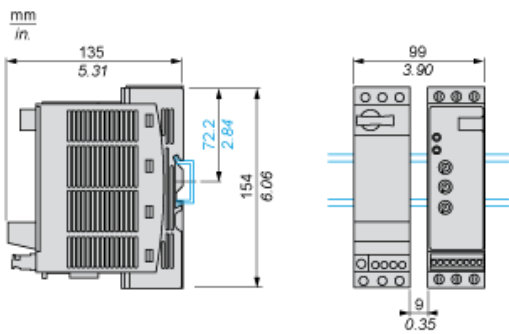

Power Wiring

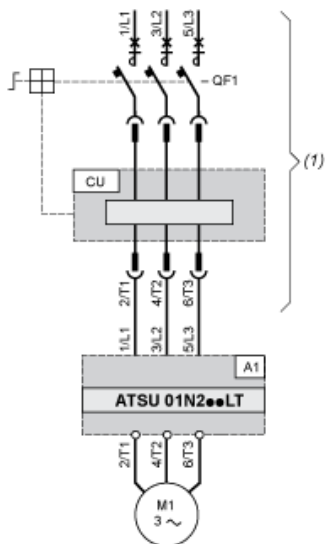

- (1) TeSys U  
A1 : Soft start/soft stop unit  
QF1 :TeSys U controller-starter  
CU : TeSys U control unit

With Reversing Unit

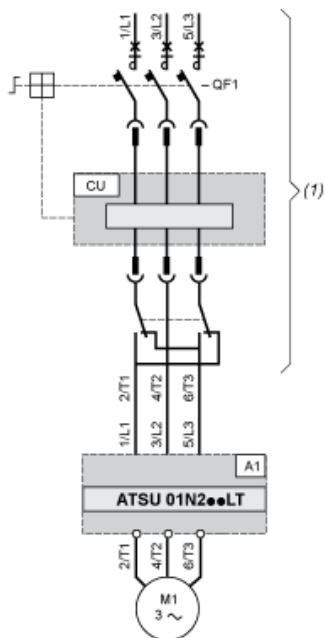

- (1) TeSys U with reversing unit  
A1 : Soft start/soft stop unit  
QF1 :TeSys U controller-starter  
CU : TeSys U control unit

Control Wiring

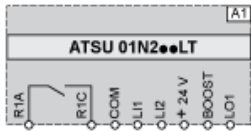

A1 : Soft start/soft stop unit

R1A, Relay output NO

R1C :

COM Commun

L11, Logic inputs (stop and run functions)

L12 :

BOOST Logic input (boost on start-up function)

LO1 :Logic output

---

Functional Diagram Automatic 2-wire Control

---

Without Deceleration

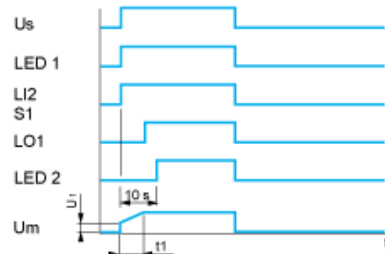

Us : Power supply voltage  
LED Green LED  
1 :  
LI2 : Logic input  
S1 : Pushbutton  
LED Yellow LED  
2 :  
Um : Motor voltage  
t1 : Acceleration time can be controlled by a potentiometer  
U1 : Starting time can be controlled by a potentiometer

With and without Deceleration

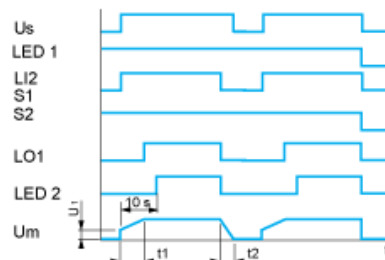

Us : Power supply voltage  
LED Green LED  
1 :  
LI2 : Logic input  
S1, Pushbuttons  
S2 :  
LO1 : Logic output  
LED Yellow LED  
2 :  
Um : Motor voltage  
t1 : Acceleration time can be controlled by a potentiometer  
t2 : Deceleration time can be controlled by a potentiometer  
U1 : Starting time can be controlled by a potentiometer

---

Functional Diagram Automatic 3-wire Control

---

## Without Deceleration

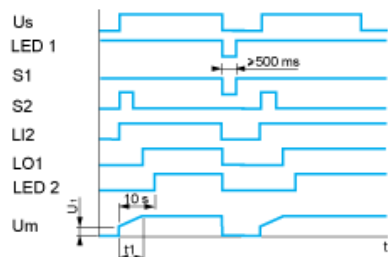

Us : Power supply voltage

LED Green LED

1 :

S1, Pushbuttons

S2 :

LI2 : Logic input

LO1 : Logic output

LED Yellow LED

2 :

Um : Motor voltage

t1 : Acceleration time can be controlled by a potentiometer

U1 : Starting time can be controlled by a potentiometer

## With Deceleration



Us : Power supply voltage

LED Green LED

1 :

S1, Pushbuttons

S2 :

LI1, Logic inputs

LI2 :

LO1 : Logic output

LED Yellow LED

2 :

Um : Motor voltage

t1 : Acceleration time can be controlled by a potentiometer