

dualFLOW™/quadFLOW™ CPU Coolers for Servers



Description: Designed for cooling dense 1U or 2U applications using CPUs fit the Intel™ LGA2011 square and LGA2066 sockets (Socket R)

Heat Sink Type: Heat Sink with Blower

Heat Sink Attachment: Hardware Kit - ATS-HK152-R0

Features & Benefits

- « Ideal for 1U and 2U applications where space and airflow are restricted
- « Designed for CPUs that fit the Intel™ LGA2011 square and LGA2066 sockets (Socket R)
- « Mechanical attachment is PEM, screws and spring – for other types of attachments contact ATS
- « Provided with Chomerics T670 thermal grease
- « Hardware provides 9.2 PSI (63 kPa) when installed
- « PWM enabled blower: 10.8 VDC ~ 13.2 VDC operating voltage
- « Provides at least 20% improvement over comparable products on the market
- « To apply this heat sink to other high power devices and processors contact ATS
- « Patent Pending



*Image is for illustration purposes only.



dualFLOW™ airflow direction



quadFLOW™ airflow direction

Product Details

P/N	DIM A	DIM B	DIM C	DIM D	DIM E	Fin Material	Finish	Weight (g)	R (°C/W) ⁽²⁾⁽³⁾	Max TDP (W)	Application Notes
ATS-UC-QFLOW-100	92.38	92.11	29	80	80	Al	Nickel Plated	456	0.21	152	For PCB layouts with restricted airflow, aluminum fins reduce weight and air enters the heat sink from four directions
ATS-UC-DFLOW-100	92.38	92.11	29	80	80	Al	Nickel Plated	436	0.20	160	For less-restricted PCB layouts, aluminum fins reduce weight and air enters the heat sink from two directions
ATS-UC-QFLOW-200	92.38	92.11	29	80	80	Cu	Nickel Plated	580	0.20	160	For dense PCB layouts, copper fins improve heat spreading and air enters heat sink from four directions
ATS-UC-DFLOW-200	92.38	92.11	29	80	80	Cu	Nickel Plated	566	0.19	170	For less-dense PCB layouts, copper fins improve heat spreading and air enters heat sink from two directions
ATS-UC-QFLOW-VC-200	92.38	92.11	29	80	80	Cu	Nickel Plated	493	0.20	160	For dense PCB layouts, vapor chamber base maximizes heat spreading from small heat sources and air enters from four directions
ATS-UC-DFLOW-VC-200	92.38	92.11	29	80	80	Cu	Nickel Plated	479	0.20	160	For less-dense PCB layouts, vapor chamber base maximizes heat spreading from small heat sources and air enters from two directions

BLOWER CONNECTOR

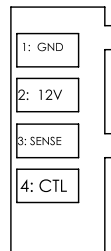

NOTES:

1. Thermal performance data are provided for reference only. Actual performance may vary by application.
2. Thermal resistance data are for 40 x 40mm component.
3. Thermal resistance is based on 100% duty cycle of the blower
4. The fan connector can be mated to a system in the following ways: via a computer motherboard's included 4-pin header, to a standard 4-pin fan header such as the Molex 0470531000 or a standard 3-pin fan header. If a 3-pin header is used, the speed control option cannot be accessed.
5. Lead wires: Pin 1-Black (-), Pin 2-Red (+12V), Pin 3-Yellow (Tach), Pin 4-Blue (PWM)
6. Max TDP (thermal design power) – maximum amount of heat generated by component
7. ATS reserves the right to update or change its products without notice to improve the design or performance
8. RoHS-6 and REACH compliant

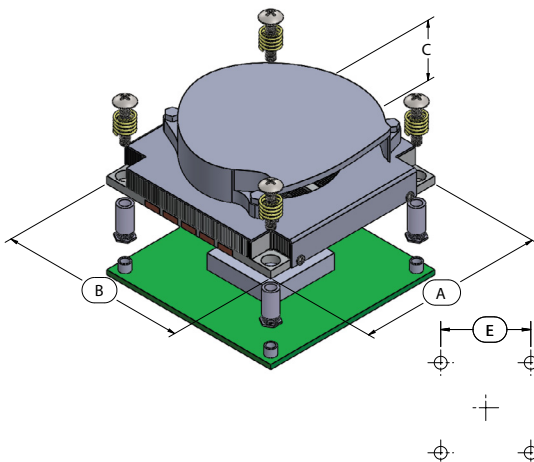

ATS ADVANCED THERMAL SOLUTIONS, INC.
Innovations in Thermal Management®

For further technical information, please contact Advanced Thermal Solutions, Inc.

89-27 ACCESS ROAD, NORWOOD, MA 02062 USA | T: 781.769.2800 | WWW.QATS.COM | ATS-HQ@QATS.COM