

Ultra High Performance BGA Cooling Solutions w/ Thermal Tape Attachment*

DIGI-KEY PART # **ATS1125-ND**

ATS PART # **ATS-52350G-C2-R0**

Features & Benefits

maxiFLOW™ design features a low profile, spread fin array that maximizes surface area for more effective convection (air) cooling

Fabricated from extruded aluminum, which minimizes thermal resistance from the base to the fins, reduces weight and keeps costs low

Higher performance helps ensure reliable product life at a lower cost than other extruded heat sinks

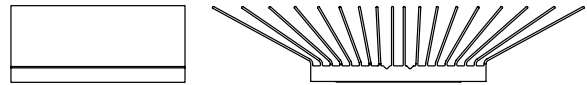
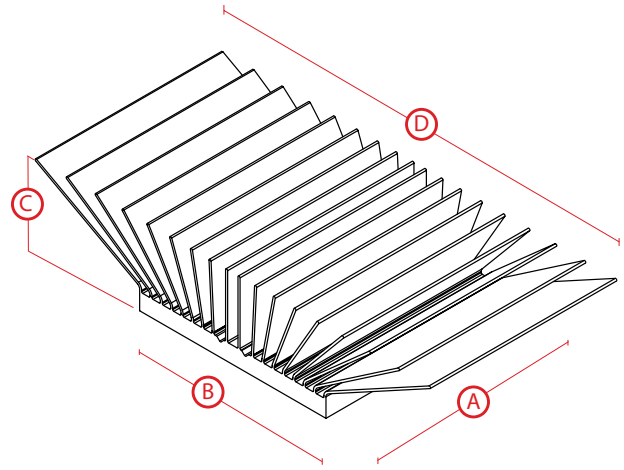

Thermal Performance Table

AIR VELOCITY		THERMAL RESISTANCE	
FT/MIN	M/S	°C/W (UNDUCTED)	°C/W (DUCTED)
200	1.0	3	2.2
300	1.5	2.3	
400	2.0	2	
500	2.5	1.8	
600	3.0	1.6	
700	3.5	1.5	
800	4.0	1.4	

Product Details†

DIMENSION A	DIMENSION B	DIMENSION C§	DIMENSION D	TIM‡	FINISH
35	35	12.5	57.22	C675	BLUE-ANODIZED

For further technical information, please contact Advanced Thermal Solutions, Inc. at **1-781-769-2800** or **www.qats.com**

* RoHS Compliant

‡ TIM = Thermal Interface Material

† Dimensions are measured in millimeters

◆ Dimensions A & B refer to component size

§ Dimension C = the height of the heat sink shown above and does not include the height of the attachment method



ATS ADVANCED THERMAL SOLUTIONS, INC.

Innovations in Thermal Management®



To place an order, please visit **www.digikey.com**